

Talentum® I2555

Air Purge Kit for Flameproof (Exd) Flame Detector

Application

The Air Purge kit is intended to be mounted in between a Flameproof (ExD) Flame Detector and adjustable mounting bracket, with the Air Purge kit nozzle positioned to channel air from the inlet onto the window of the flame detector to prevent obscuration by particles

Weight

0.44 lbs (0.2 kg)

Mounting

The Air Purge nozzle must be angled at 45° from horizontal in order to maximize the air flow over the front window.

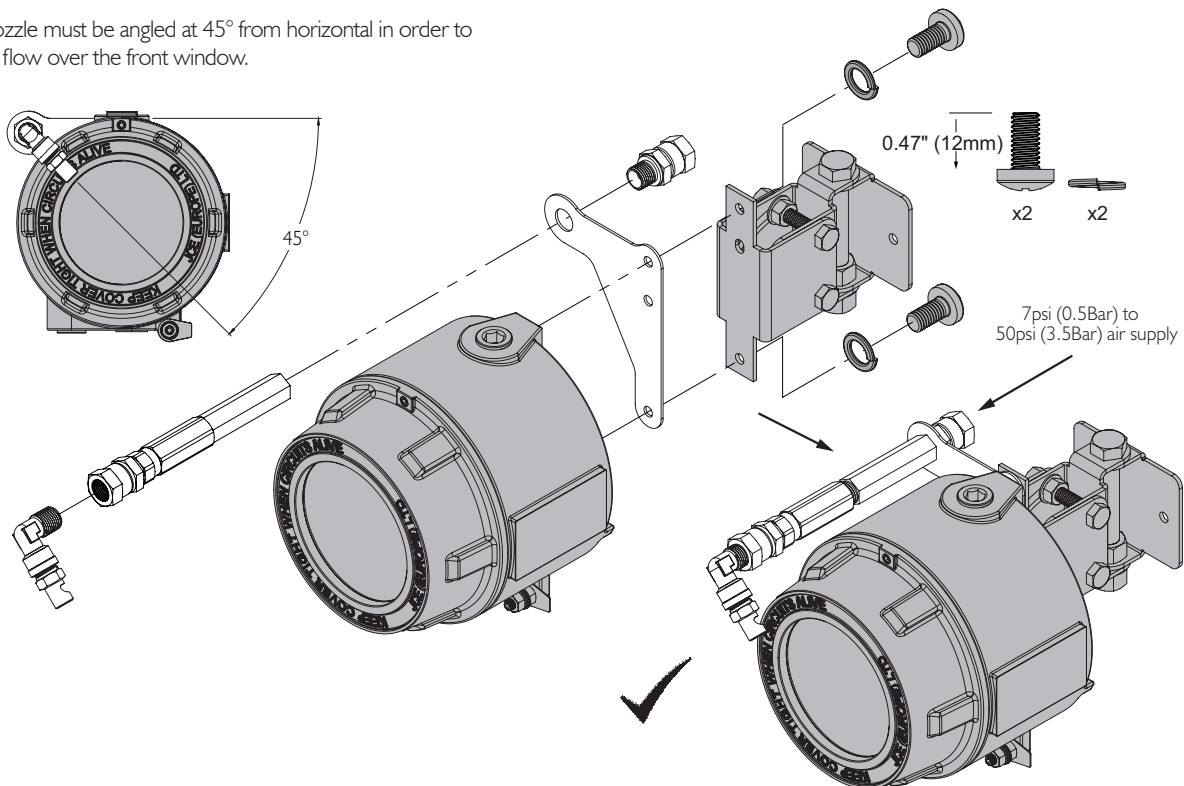

Installation

- The purge air adapter should be connected to an external air supply via the female 1/4" BSP non return valve
- The air should be oil free and dry with a pressure range from 7psi (0.5Bar) to 50psi (3.5Bar)
- If the air is not required continuously to keep the viewing window clean then a pulse of air can be supplied at regular intervals
- **CAUTION:** This product is not suitable for use in ATEX zone 0 - For use in ATEX zone 1/21 or 2/222, air must be clean and the system blown through before placing in a hazardous environment