

E-PHD Photoelectric and Fixed Temperature Heat Detector Installation Sheet

Operation

The E-PHD Photoelectric and Fixed-Temperature Heat Detector uses an optical sensing chamber to detect smoke and a fixed-temperature heat sensor to detect heat from fire. The detector analyzes the sensor data to determine when to initiate an alarm. The detector continuously monitors changes in sensitivity due to the environment (e.g., dirt, smoke, temperature, humidity) and notifies the control panel of its condition. The heat sensor monitors the temperature of the air in its surroundings and determines whether an alarm should be initiated.

The detector is capable of performing comprehensive self-diagnostics and storing the results. The detector issues a dirty sensor warning when it reaches its preset limit. This notifies the operator of the need for service while the detector is still operating.

LED operation

The detector provides a bicolor LED that shows its status.

- Normal: Green LED flashes
- Alarm/active: Red LED flashes

Installation

Refer to *Edwards Signaling Smoke and Heat Detectors Applications Bulletin* (P/N 3101212) for additional information on detector placement and spacing.

WARNINGS

- This detector does not operate without electrical power. As fires frequently cause power interruption, discuss further safeguards with the local fire protection specialist.
- This detector does not sense fires in areas where smoke cannot reach the detector. Smoke from fires in walls, roofs, or on the opposite side of closed doors may not reach the detector.
- Photoelectric detectors have a wide range of sensing capabilities, but are best suited for detecting slow, smoldering fires.
- To ensure proper operation, schedule maintenance (regular or selected) in accordance with the requirements of the authority having jurisdiction. Refer to NFPA 72 and CAN/ULC-S536.

- To ensure proper operation, store the detector within the recommended ranges. Allow the detector to stabilize to room temperature before applying power.
- Keep the dust cover (supplied) on the detector during installation and remove it prior to commissioning and service. The dust cover is not a substitute for removing the detector during new construction or heavy remodeling.

To install the detector:

1. Install and wire the detector base using the installation sheet supplied with the detector base.
2. Set the detector address. Refer to the panel technical reference manual for a list of valid addresses. Use a screwdriver to adjust the two rotary switches on the back of the detector. Set the left rotary switch (0 through 12) for the 10s and 100s digit and the right rotary switch for the 0 through 9 digit.
3. Connect the detector to the base by rotating the detector clockwise until it snaps into the locked position.
The head can be removed by turning it counterclockwise.
4. If the head must lock to the base, break away the locking tab using a pair of pliers.

To then remove the detector head after breaking away the locking tab, insert a small screwdriver into the slot on the side of the base and press in while simultaneously turning the detector head counterclockwise.

Figure 1 : Setting detector address (address 32 shown)

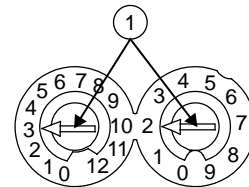

1. Insert screwdriver here

Figure 2: Breakaway tab

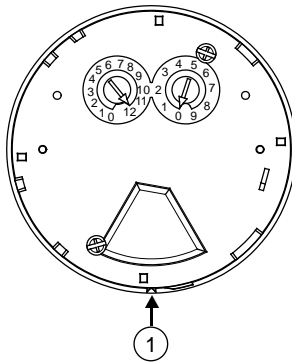

1. Breakaway tab

Maintenance

Cleaning the detector

When cleaning is necessary, the sensing chamber of the detector unsnaps for easy field cleaning and service.

Note: Only the smoke element of the detector requires cleaning.

To clean the detector:

1. Remove the detector from the base.
2. Insert a screwdriver in the small slot where the detector cap connects to the detector body.
3. Pry the detector cap off the detector body.
4. Squeeze the optical block chamber where the two arrows point, labeled “squeeze here.”
5. Pull off the optical block chamber.
6. Blow off the optical block base in the detector body using clean compressed air.
7. Snap a new optical block chamber in place. Make sure you line up the two arrows on the block chamber with the snaps on the optical block base.
8. Connect the detector cap to the detector body by rotating the cap clockwise until it snaps into a locked position.
9. Install the detector onto the base.

Note: To verify the effectiveness of the cleaning, recalibrate the device and run a device maintenance report. Refer to the control panel technical reference manual.

10. Test the detector and verify sensitivity.

Figure 3: Detector disassembly

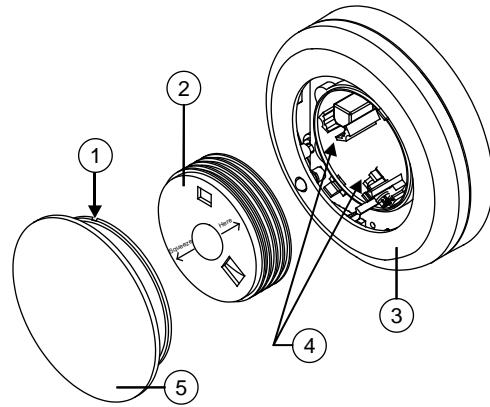

1. Slot to insert screwdriver
2. Optical block chamber
3. Detector body
4. Optical block base
5. Detector cap

Test

NFPA 72 and CAN/ULC-S537 code require calibrated sensitivity test upon completion of the original installation and following any modifications or additions to the system. The detector can perform this test and generate a system sensitivity report.

Note: Test both the smoke element and the heat element of the detector.

To test the detector:

1. Before initial testing, remove the dust cover from the detector and notify the proper authorities that the fire alarm system is undergoing maintenance and will be temporarily out of service.
2. Test the detector’s smoke element using Smoke! In A Can (model SM-200), canned smoke. Carefully follow directions on the can to avoid damage to the detector.
3. Test the detector’s heat element using a heat gun maintaining a six-inch minimum distance. Use caution as excess heat can damage the detector and detector housing.

Specifications

Communication line voltage	Maximum 20 V peak-to-peak
Normal operating current	45 μ A
Alarm current	45 μ A
Smoke sensitivity range	
UL	0.67 to 3.66%/ft. obscuration
ULC	0.87 to 3.70%/ft. obscuration
UL/ULC fixed-temp alarm rating	135°F (57°C)
Environmental compensation	Automatic
Compatible bases	Standard: B4U, B4U-LP Relay: RB4U Isolator: IB4U Audible: SB4U
Maximum distance from ceiling wall-mounted	12 in. (305 mm)
Storage temperature	-4 to 140° F (-20 to 60° C)
Operating environment	
Temperature	32 to 120° F (0 to 49° C)
Humidity	0 to 93% RH, noncondensing at 90° F (32° C)

Certification and compliance

Manufacturer [1]	Edwards, A Division of UTC Fire & Security Americas Corporation, Inc. 8985 Town Center Parkway, Bradenton, FL 34202, USA
Year of manufacture	The first two digits of the date code (located on the product identification label) are the year of manufacture.
North American standards	Meets: UL 268, ULC-S529-02, UL 521, ULC S530 M91 Follow: NFPA 72, and CAN/ULC S524

[1] For warranty and return see "Contact information" below

Contact information

For contact information, see our Web site:
www.edwardssignaling.com.

