

SIEMENS

Installation Instructions

Model ACM-1

Audio Control Module

INTRODUCTION

The Model ACM-1 Audio Control Module from Siemens Industry, Inc. is the master control module for the MXLV audio system. The module controls all Voice related functions. It has two yellow LEDs—the TROUBLE LED indicates ACM-1 troubles and the TRANSMIT LED monitors network activity. Refer to Figure 1 for the location of the LEDs. (These troubles also appear on the MKB-2 panel.)

ACM-1 has a supervised tone generator which provides a variety of tones for use with the system. Each system can have two of the available tones. The tones are set with CSG-M. If an application requires tone backup, use the P6 connector on the ACM-1 for the BTC-1 Backup Tone card. (Refer to Figure 1.)

The ACM-1 occupies one network address. The switch S102 shown in Figure 2 is used to set the network address that was chosen in CSG-M for the ACM-1 module.

OPERATIONS

1. The ACM-1 controls and supervises the preamplifier circuit for the microphone and wiring for the retractable cord. The preamplifier circuit controls the volume of any signal that enters the circuit.
2. When the microphone key is pressed, the ACM-1 sends the preannounce tone that was configured in CSG-M, making the microphone the source for audio channel 1.

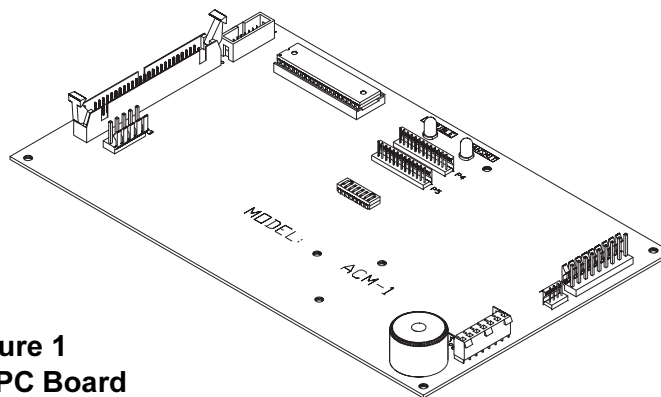

Figure 1
ACM-1 PC Board

Siemens Industry, Inc.
Building Technologies Division
Florham Park, NJ

P/N 315-092083-10

Siemens Building Technologies, Ltd.
Fire Safety & Security Products
2 Kenview Boulevard
Brampton, Ontario
L6T 5E4 Canada

3. The ACM-1 also controls a small local speaker in the MMM-1 module. Any of several signals available in the System can be sent to this speaker if selected in CSG-M.
4. Three supervised riser circuits provide low power audio signals to the OCC-1 to be sent to power amplifiers. The ACM-1 can also connect these risers to an auxiliary non-emergency signal source for use in non-emergency audio applications.
5. The Audio Control module communicates with the VSM-1 Voice Switch modules, the VLM-1 Voice LED modules, and the VFM-1 Fan Control modules that are part of the system. The VSM-1 modules provide firefighters with a means of controlling nonautomatic functions of the MXLV system.

The VLM-1 modules provide status indications of the System. The VFM-1 modules provide the system operator with automatic and manual control and annunciation of fan control functions for building management. These functions are set in CSG-M. For more information about the VSM-1, VLM-1, and VFM-1,

refer to the *MXLV Manual*, P/N 315-092036, and the *VLM-1//VSM-1/VFM-1 Instructions*, P/N 315-092064.

6. The ACM-1 controls the warden's page that comes from the TMM-1 Telephone Master module. When activated, the warden's page becomes the audio source for selected speaker zones.

INSTALLATION

Remove all system power before installation, first battery and then AC. (To power up, connect the AC first, then the battery.)

To set the network address of the module:

1. Remove the ACM-1 from its protective bag.
2. Refer to the CSG-M configuration printout for the address of the ACM-1 module.
3. Set the ACM-1 address on switch S102. (Refer to Figure 2 for the location of S102.)

**Figure 2
Mounting the ACM-1**

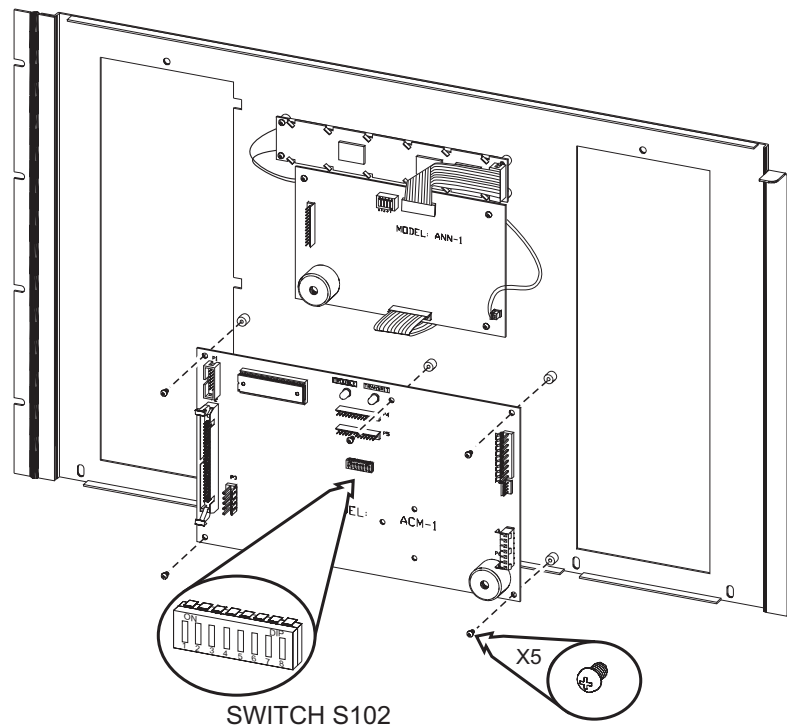

4. Find the correct setting for the ACM-1 address in Table 1 on page 6 of these instructions and use dipswitch S102, switches SW1 through SW8, to set the address for the module.

NOTE: To open a dipswitch, press down on the side of the dipswitch marked OPEN. To close a dipswitch, press down on the side of the dipswitch opposite the side marked OPEN.

To open a slide switch, push the slide to the side opposite the side marked ON. To close a slide switch, push the slide to the side marked ON.

To mount the ACM-1 module:

The ACM-1 may be mounted in two different locations in the enclosure, depending on whether or not there is an MKB-2 in the enclosure. (In some cases an MHD-3 is used instead of the MKB to enable the use of more VSMs in a system.)

1. When an MKB-2 is in the top position of the system enclosure:

- a. Mount the ACM-1 module on the back of the MKB-2 front panel, below the ANN-1 module. Check that the ribbon cable connector P1 is in the upper left corner of the board before mounting.
- b. With the board in that position, place the module over the five threaded mounting spacers. (See Figure 2.)
- c. Fasten the module in place with the No. 6 screws provided.

2. When an MHD-3 is used in the top position of the enclosure (instead of an MKB-2):

- a. Mount the ACM-MPT bracket on the 4 studs located in the lower right hand corner of the MME-3 backbox. (These are the same studs used for a TSP-40 printer.) Secure the bracket with the four nuts provided. (See Figure 3.)
- b. Be sure that P1 is in the upper right hand corner of the ACM. (Refer to Figure 3.) Mount the ACM-1 PC board over the six threaded mounting spacers.
- c. Fasten the module in place with the five No. 6 screws provided (one of the spacers is used for support). (Refer to Figure 3.)

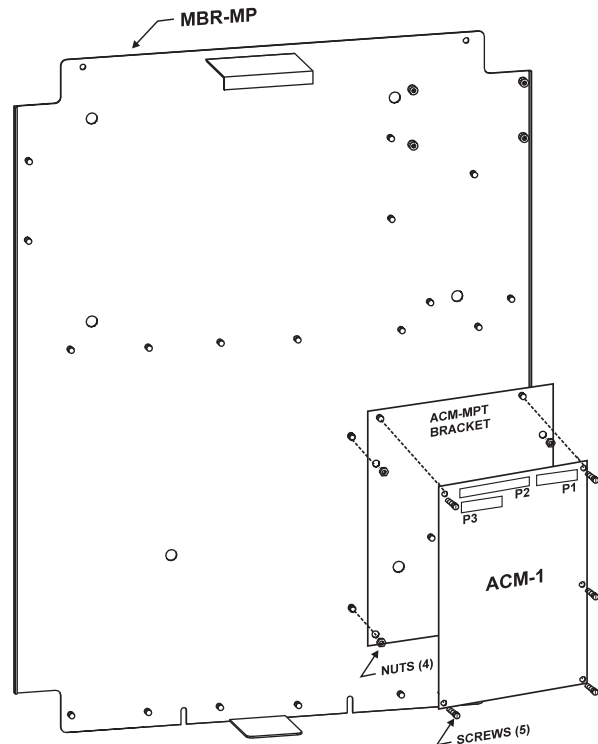

Figure 3
Alternate Mounting of ACM-1

To wire the ACM-1:

The ACM-1 can be wired in two different configurations: One wiring configuration is used if an MMB (or PSR) supplies the power and data communications (See Figure 4).

The other wiring configuration is used where a PS-5N7 supplies the power and data communications, as in a remote expander board (See Figure 5).

The wiring information below is unaffected by whether the ACM-1 module is in the upper or lower position of the enclosure.

CAUTION:

Remember that all cables that connect to the ACM-1 are polarized and connect in one way only. DO NOT FORCE THEM. The location of pin 1 on a connector is indicated by marks on the pin or by color tracers on the wires. In Nos. 1 and 2 below, be sure the black tracer wire is close to the 1.

1. To wire the ACM-1 in an enclosure that has an MMB or a PSR (Refer to Figure 4):

- Connect the long 15-ribbon cable (P/N 555-192238) from the MMB, P8 (or PSR-1, P5) to P5 on the ACM-1.
- Connect the short 15-conductor ribbon cable (P/N 555-192242) from ANN-1, P3 to P4 on the ACM-1.
- Connect the 14-conductor ribbon cable (P/N 555-192236) from TMM-1, P3 to P1 on the ACM-1, if used.
- Connect the 50-conductor ribbon cable (P/N 555-192201) from TBM-2, P3 to P2 on the ACM-1.
- Connect the 5-conductor wire cable (P/N 600-190220) from TBM-2, P2 to P3 on the ACM-1.
- P6 on the ACM-1 is connected to an optional BTC-1 module, if used.
- If an MMM-1 is used, connect the 9-conductor cable attached to the MMM-1 to P7 on the ACM-1.

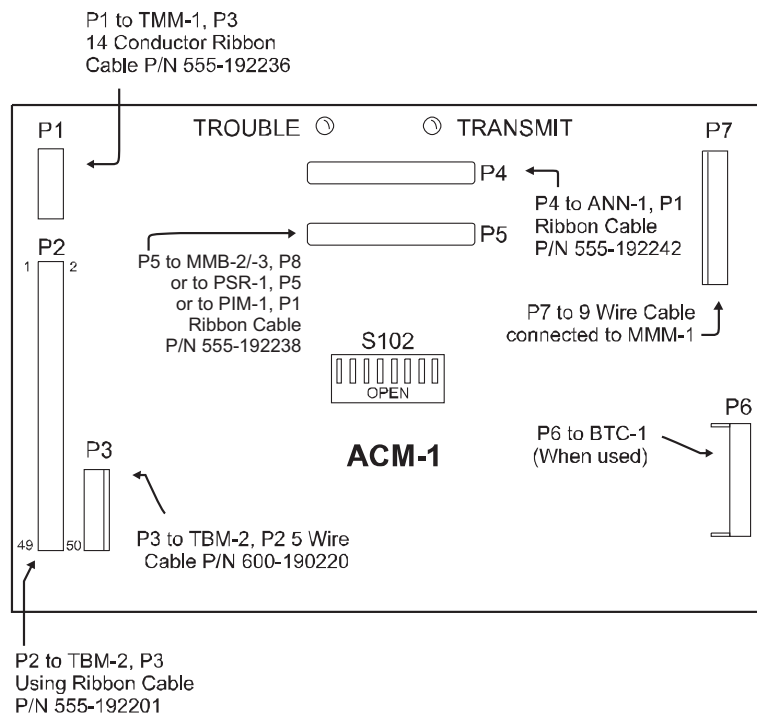

Figure 4
Wiring an ACM-1 that is Mounted on an MKB-2

2. To wire an ACM-1 module when PS-5N7 is used to supply power and for data communication (instead of an MMB or a PSR):

- a. Connect the long 15-conductor ribbon cable (P/N 555-192238) from the PS-5N7, P1 to P5 on the ACM-1.
- b. Connect the 50-conductor ribbon cable (P/N 555-192201) from TBM-2, P3 to P2 on the ACM-1.
- c. Connect the 5-conductor wire cable (P/N 600-190220) from TBM-2, P2 to P3 on the ACM-1.

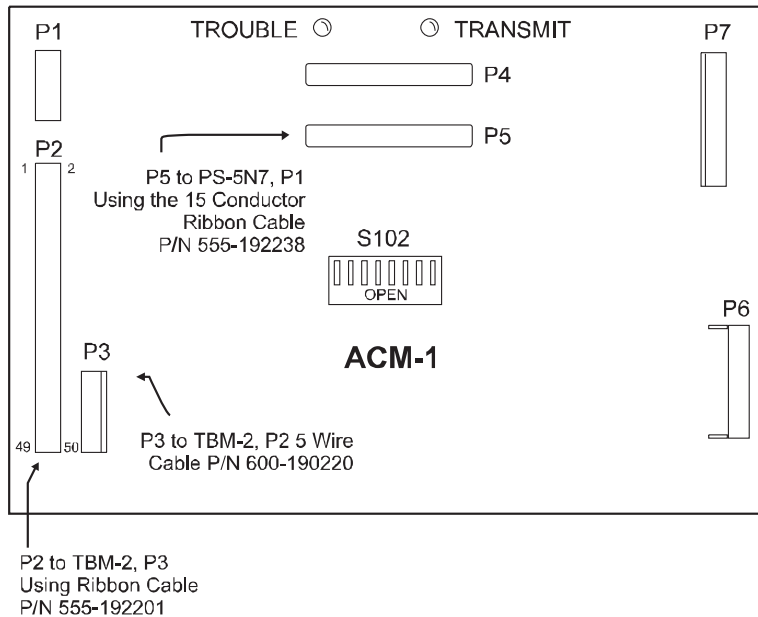

Figure 5
Wiring an ACM-1 in a Remote Expander Enclosure

ELECTRICAL RATINGS

Active 5VDC Module Current	176mA
Active 24VDC Module Current	85mA
Standby 24VDC Module Current	129mA

For additional information on the MXL/MXLV System, refer to the *MXL/MXLV Manual, P/N 315-092036*.

**TABLE 1
NETWORK ADDRESS PROGRAMMING**

ADDR	87654321	ADDR	87654321	ADDR	87654321	ADDR	87654321
000	ILLEGAL	064	OX000000	128	X0000000	192	XX000000
001	ILLEGAL	065	OX00000X	129	X000000X	193	XX00000X
002	ILLEGAL	066	OX00000X	130	X000000X	194	XX00000X
003	000000XX	067	OX0000XX	131	X00000XX	195	XX0000XX
004	00000X00	068	OX000X00	132	X0000X00	196	XX000X00
005	00000X0X	069	OX000X0X	133	X0000X0X	197	XX000X0X
006	00000XX0	070	OX000XX0	134	X0000XX0	198	XX000XX0
007	00000XXX	071	OX000XXX	135	X0000XXX	199	XX000XXX
008	0000X000	072	OX00X000	136	X000X000	200	XX00X000
009	0000X00X	073	OX00X00X	137	X000X00X	201	XX00X00X
010	0000X0X0	074	OX00X0X0	138	X000X0X0	202	XX00X0X0
011	0000X0XX	075	OX00X0XX	139	X000X0XX	203	XX00X0XX
012	0000XX00	076	OX00XX00	140	X000XX00	204	XX00XX00
013	0000XX0X	077	OX00XX0X	141	X000XX0X	205	XX00XX0X
014	0000XX0X	078	OX00XX0X	142	X000XX0X	206	XX00XX0X
015	0000XXXX	079	OX00XXXX	143	X000XXXX	207	XX00XXXX
016	000X0000	080	OX0X0000	144	X00X0000	208	XX0X0000
017	000X000X	081	OX0X000X	145	X00X000X	209	XX0X000X
018	000X00X0	082	OX0X00X0	146	X00X00X0	210	XX0X00X0
019	000X00XX	083	OX0X00XX	147	X00X00XX	211	XX0X00XX
020	000X0X00	084	OX0X0X00	148	X00X0X00	212	XX0X0X00
021	000X0X0X	085	OX0X0X0X	149	X00X0X0X	213	XX0X0X0X
022	000X0XX0	086	OX0X0XX0	150	X00X0XX0	214	XX0X0XX0
023	000X0XXX	087	OX0X0XXX	151	X00X0XXX	215	XX0X0XXX
024	000XX000	088	OX0XX000	152	X00XX000	216	XX0XX000
025	000XX00X	089	OX0XX00X	153	X00XX00X	217	XX0XX00X
026	000XX0X0	090	OX0XX0X0	154	X00XX0X0	218	XX0XX0X0
027	000XX0XX	091	OX0XX0XX	155	X00XX0XX	219	XX0XX0XX
028	000XXX00	092	OX0XXX00	156	X00XXX00	220	XX0XXX00
029	000XXX0X	093	OX0XXX0X	157	X00XXX0X	221	XX0XXX0X
030	000XXXX0	094	OX0XXXX0	158	X00XXXX0	222	XX0XXXX0
031	000XXXXX	095	OX0XXXXX	159	X00XXXXX	223	XX0XXXXX
032	00X00000	096	OXX00000	160	X0X00000	224	XXX00000
033	00X0000X	097	OXX0000X	161	X0X0000X	225	XXX0000X
034	00X000X0	098	OXX000X0	162	X0X000X0	226	XXX000X0
035	00X000XX	099	OXX000XX	163	X0X000XX	227	XXX000XX
036	00X00X00	100	OXX00X00	164	X0X00X00	228	XXX00X00
037	00X00X0X	101	OXX00X0X	165	X0X00X0X	229	XXX00X0X
038	00X00X0X	102	OXX00X0X	166	X0X00X0X	230	XXX00X0X
039	00X00XXX	103	OXX00XXX	167	X0X00XXX	231	XXX00XXX
040	00X0X000	104	OXX0X000	168	X0X0X000	232	XXX0X000
041	00X0X00X	105	OXX0X00X	169	X0X0X00X	233	XXX0X00X
042	00X0X0X0	106	OXX0X0X0	170	X0X0X0X0	234	XXX0X0X0
043	00X0X0XX	107	OXX0X0XX	171	X0X0X0XX	235	XXX0X0XX
044	00X0XX00	108	OXX0XX00	172	X0X0XX00	236	XXX0XX00
045	00X0XX0X	109	OXX0XX0X	173	X0X0XX0X	237	XXX0XX0X
046	00X0XXX0	110	OXX0XXX0	174	X0X0XXX0	238	XXX0XXX0
047	00X0XXXX	111	OXX0XXXX	175	X0X0XXXX	239	XXX0XXXX
048	00XX0000	112	OXXX0000	176	X0XX0000	240	XXX00000
049	00XX000X	113	OXXX000X	177	X0XX000X	241	XXX0000X
050	00XX00X0	114	OXXX00X0	178	X0XX00X0	242	XXX000X0
051	00XX00XX	115	OXXX00XX	179	X0XX00XX	243	XXX000XX
052	00XX0X00	116	OXXX0X00	180	X0XX0X00	244	XXX0X000
053	00XX0X0X	117	OXXX0X0X	181	X0XX0X0X	245	XXX0X00X
054	00XX0XX0	118	OXXX0XX0	182	X0XX0XX0	246	XXX0XX00
055	00XX0XXX	119	OXXX0XXX	183	X0XX0XXX	247	XXX0XXX0
056	00XXX000	120	OXXXX000	184	X0XXX000	248	ILLEGAL
057	00XXX00X	121	OXXXX00X	185	X0XXX00X	249	ILLEGAL
058	00XXX0X0	122	OXXXX0X0	186	X0XXX0X0	250	ILLEGAL
059	00XXX0XX	123	OXXXX0XX	187	X0XXX0XX	251	ILLEGAL
060	00XXX0X0	124	OXXXX0X0	188	X0XXX0X0	252	ILLEGAL
061	00XXX0XX	125	OXXXX0XX	189	X0XXX0XX	253	ILLEGAL
062	00XXXX00	126	OXXXX000	190	X0XXXX00	254	ILLEGAL
063	00XXXXXX	127	OXXXX0XX	191	X0XXXXXX	255	ILLEGAL

O = OPEN (or OFF) X = CLOSED (or ON)

Siemens Industry, Inc.
Building Technologies Division
Florham Park, NJ

P/N 315-092083-10

Siemens Building Technologies, Ltd.
Fire Safety & Security Products
2 Kenview Boulevard
Brampton, Ontario
L6T 5E4 Canada