

Technology that saves lives

# BMS Communications Field Server Bridge

## SA-FSB



**SA-FSB**  
Serial/Ethernet Bridge



### Overview

The BMS Communication Bridges are ancillary devices that provide protocol translation between VS1 or VS4 control panel serial data and the serial or Ethernet input of an external device controller. Signal flow is typically one way — from the life safety panel to the network to the building automation system.

The communication bridge comes with the MODBUS protocol, other protocols are available by a simple download, see the installation instruction on directions to obtain the other available protocols.

**The SA-FSB** is a multi-protocol bridge that converts the panel's RS-232 output (printer port) to any one of the several supported protocols including Modbus RTU, Modbus TCP, BACnet MSTP, BACnet IP/Eth, and DNP Ethernet. The SA-FSB is shipped with the Modbus TCP protocol. Follow the installation instructions to download one of the other supported protocols.

The communications bridge operates over RS-232 serial communication from the fire alarm control panel and to the BMS via RS-485 or Ethernet (10/100 Base-T).

It communicates with the panel through an RS-232 connection using the optional SA-232 card. It communicates with the BMS through an RS-485 or Ethernet connection.

### Standard Features

- **Links VS1 or VS4 with building management system**  
Sends events to a BMS system via serial or Ethernet connections, helping to reduce interface hardware costs
- **Supplied with field protocols, Modbus, BACnet and DNP Ethernet**  
One module provides selection of any single protocol – no need to purchase separate software or hardware modules
- **Serial and Ethernet ports**  
Flexible connection type for the BMS system: RS-232 or Ethernet 10/100 Base-T
- **Software configuration**  
Speeds installation and setup
- **Selectable connection to BMS via RS-485 or Ethernet**  
It communicates with the panel through an RS-232 connection using the optional SA-232 card. It communicates with the BMS through an RS-485 or Ethernet connection.
- **RoHS compliant**  
Provides readiness for the Restriction of Certain Hazardous substances (RoHS) directives that are becoming prevalent in many jurisdictions.

## Application

Options selected for bridging VS1 or VS4 panels to building management systems depend on the requirements of the external device controller. Before specifying an FSB bridge, determine the communications protocol and the communications interface required by third-party equipment. Keep in mind that the SA-FSB supports either Ethernet or serial interfaces.

FSB bridges communicate with VS1 or VS4 systems via an installer-supplied RS-232 cable. This connects between the control panel's RS-232 port via the SA-232 option module to the bridge 6-pin terminal block. Software is used to select the desired communications protocol where applicable, and whether the serial or the Ethernet interface is to be used for output to field equipment.

In order to complete the bridging process, individual points need to be specified within the FSB software. This allows the bridge to relay only required data to the external device controller. To do this, use the VS-CU to identify and export a list of relevant device addresses. Then simply import this list into the FSB software and generate a new configuration file for uploading to the bridge.

## Engineering Specification

The system shall provide an interface from the fire/life safety system to the Building Management System. The interface shall be via < Modbus RTU> <BACnet MSTP> <BACnet IP> <BACnet Ethernet> <Modbus TCP/IP> protocol. The interface shall be software configurable as to which points from the fire systems shall be provided to the BMS. The BMS interface shall be powered from the main fire alarm panel, and mounted adjacent to it in a MFC-A enclosure.

## Dimensions

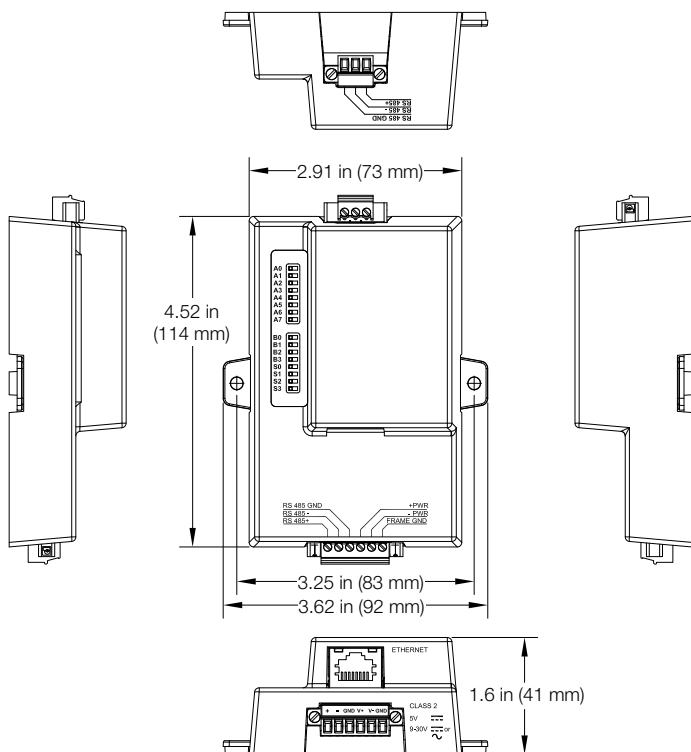

## Typical Wiring

**Protocols:**  
 Modbus RTU  
 BACnet MSTP  
 BACnet IP  
 BACnet Ethernet  
 Modbus TCP/IP

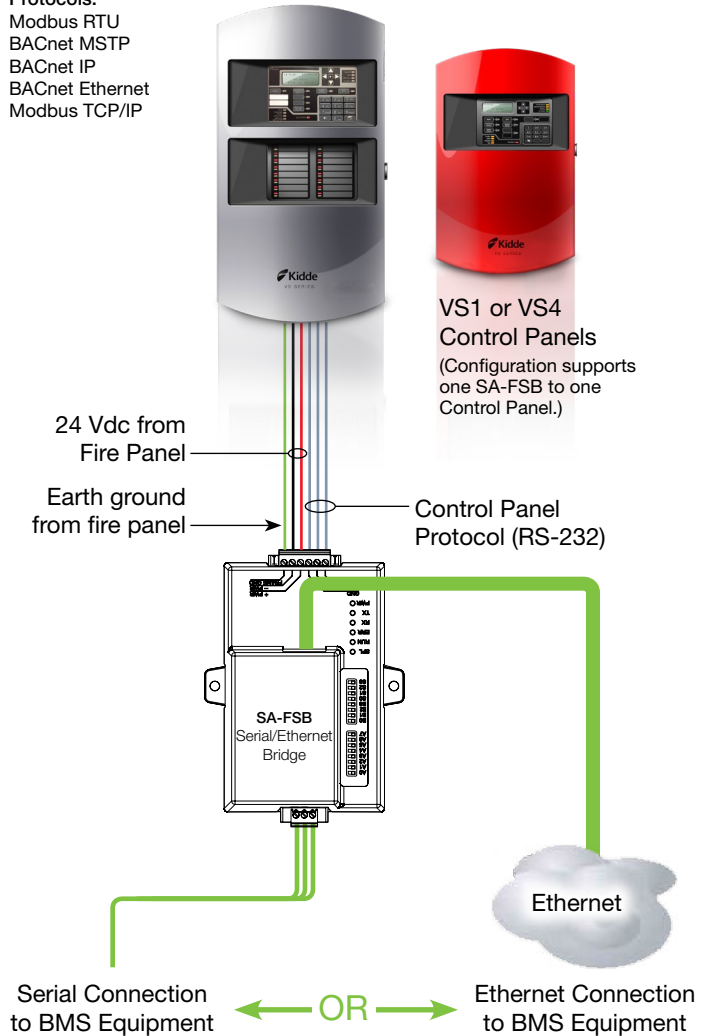

## Installation

SA-FSB bridge mounts inside the MFC-A enclosure using the separately-ordered FSB-BRKT2 mounting kit. This kit eliminates the cost and effort of installing a separate cabinet. The SA-FSB is powered from the control panel 24VDC power supply. Configuration supports one SA-FSB to one Control Panel, located no more than 50 feet.

FSB-BRKT2 mounting kit

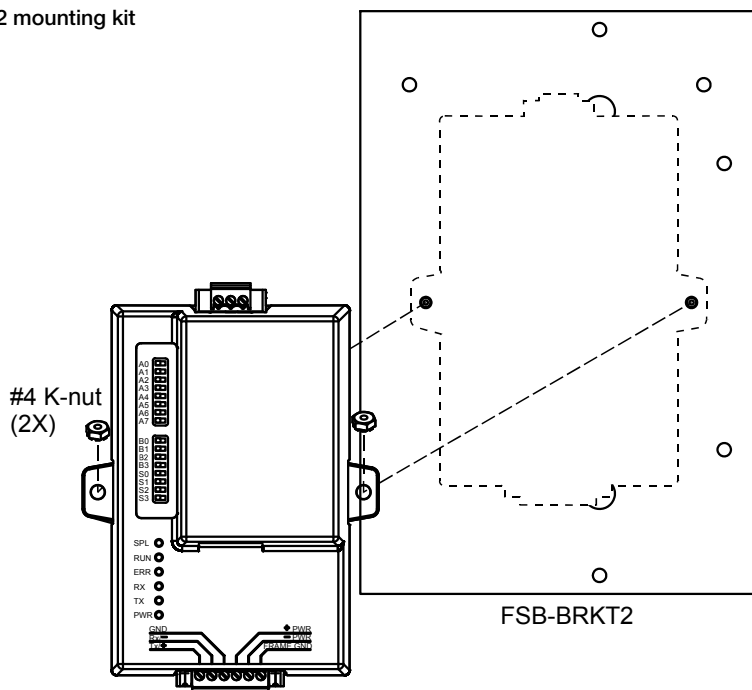

Mounting in an MFC-A Cabinet

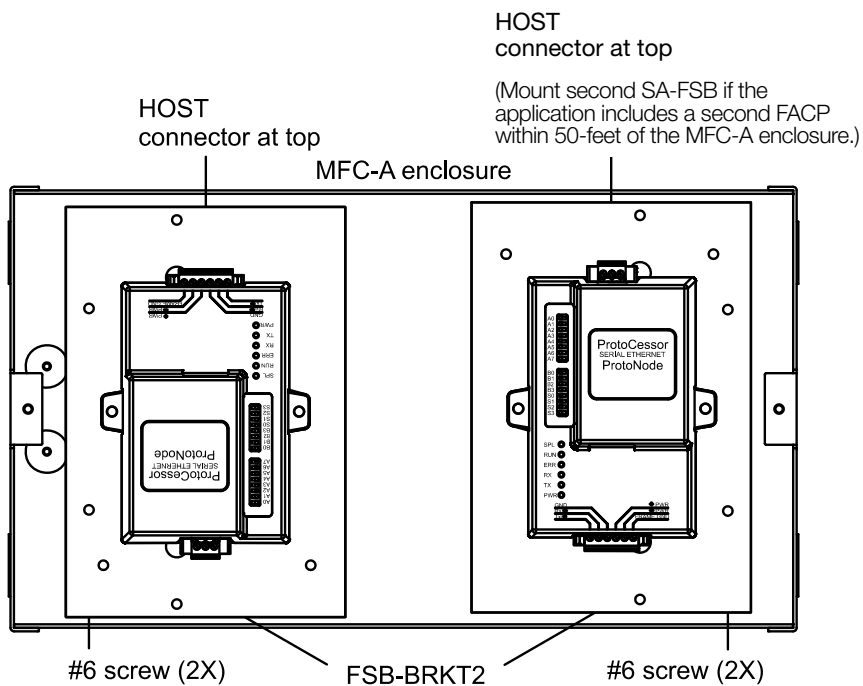



Technology that saves lives

**Contact us**

**Phone:** 888.244.9979 (Option 4)

**Email:** [kidde.fire@carrier.com](mailto:kidde.fire@carrier.com)

**Website:** [kidde-esfire.com](http://kidde-esfire.com)

Kidde is a Carrier brand.  
8985 Town Center Pkwy,  
Bradenton, FL 34202

©2021 Carrier  
All Rights Reserved.

## Technical Specifications

SA-FSB	
Communication Interfaces	Serial to fire panel: RS-232 using the SA-232 module To BMS: Serial (RS-485) or Ethernet 10/100 Base-T (auto sensing).
Supported field protocols	To Fire Panel: Serial To BMS: Modbus TCP (default), Ethernet BACnet/IP Serial: Modbus RTU, BACnetMS/TP
Points per Bridge	3,600 max. <sup>1</sup>
Operating Current	110 mA nominal, 120 mA max. (at 24 VDC)
Input voltage	9 to 30 VDC (from EST3 power supply)
Storage & Operating Environment	32 to 120 °F (0 to 49 °C) 5-90% RH, non-condensing
Regulatory Approvals	CE (EN 55022, EN 55024) Surge Suppression: EN61000-4-2 ESD, EN61000-4-3 EMC, EN61000-4-4 EFT Tested to comply with UL916 to carry the TUV Rheinland Mark. Complies with part 15 of the FCC Rules.
Construction and Finish	Light Grey metal enclosure with mounting ears.
Mounting	Within an MFC-A cabinet using mounting kit model FSB-BRKT2.
Configuration	Software programmable for protocol supported as well as specific points to be translated.
Maximum Bridges	One per VS1 or VS4
Dimensions, W × H × D	3.6 × 5.0 × 1.6 in. (8.2 × 11.5 × 4.0 cm)

<sup>1</sup> A single SA-FSB can support up to 3,600 points. Total points are a combination of the programmed points coming into the SA-FSB and the programmed points going out to the building management system. For example, if you program 1,800 points to come into the SA-FSB, you can program up to 1,800 points to go out to your building management system. See installation sheet 3102662 for further details.

## Ordering Information

Model	Description	Ship Wt. lb (kg)
SA-FSB	BMS Communications Bridge. Mounts on a FSB-BRKT2 in a MFC-A enclosure, both ordered separately.	3.0 (1.36)
FSB-BRKT2	Mounting Bracket for SA-FSB, to be mounted inside the MFC-A enclosure, both ordered separately.	1.0 (0.45)
MFC-A	Multifunction Fire Alarm Cabinet, red.	7.0 (3.1)