

Intelligent Combination Smoke/CO Detector

V-PCOS, V-PCOS-CA



Description

Vigilant brand V-PCOS photoelectric detectors bring advanced sensing technology to a practical design that increases efficiency, saves installation time, cuts costs, and extends life safety and property protection capabilities. Continuous self-diagnostics ensure reliability over the long-haul, while innovative field-replaceable smoke chambers make detector maintenance literally a snap. With its on-board CO sensor, this detector pulls double-duty — continually monitoring the environment for signs of smoke, as well as its invisible yet deadly companion, carbon monoxide.

The V-PCOS is an intelligent device that gathers analog information from its smoke and CO sensor (if present), converting this data into digital signals. To make an alarm decision, the detector's on-board microprocessor measures and analyzes sensor readings and compares this information to historical data. Digital filters remove signal patterns that are not typical of fires, thus virtually eliminating unwanted alarms.

The V-PCOS includes an advanced carbon monoxide sensor and daughterboard. When the electrochemical cell reaches its end of life after approximately six years, the detector signals a trouble condition to the control panel. The sensor/daughterboard module is field-replaceable.

Standard Features

- Optical smoke sensing technology with carbon monoxide sensor
- Field-replaceable smoke chamber
- Field-replaceable carbon monoxide sensor/daughterboard module
- Uses existing wiring
- Automatic device mapping
- Two levels of environmental compensation
- Two levels of dirty detector warning
- Twenty pre-alarm settings
- Five sensitivity settings
- Non-volatile memory
- Electronic addressing
- Environmental compensation
- Identification of dirty or defective detectors
- Identification of CO sensors approaching end of life
- Automatic day/night sensitivity adjustment
- Bicolor (green/red) status LED
- Standard, relay, fault isolator, and audible mounting bases

Application

Smoke detection

The V-PCOS detects extremely small particles of combustion and triggers an alarm at the first sign of smoke. Thanks to its high-performance forward scattering reflective response technology, the photoelectric smoke sensor responds quickly and reliably to a wide range of fire types, especially slow burning fires fuelled by combustibles typically found in modern multi-use buildings.

Carbon monoxide detection

CO detection has rapidly become a standard part of life safety strategies everywhere. Monitored CO detection is becoming mandated with increasing frequency in all types of commercial applications, but particularly in occupancies such as hotels, rooming houses, dormitories, day care facilities, schools, hospitals, assisted living facilities, and nursing homes. In fact, more than half of the U.S. population already lives in states requiring the installation of CO detectors in some commercial occupancies. This is because carbon monoxide is the leading cause of accidental poisoning deaths in America. Known as the "Silent Killer," CO is odorless, tasteless, and colorless. It claims nearly 500 lives, and results in more than 15,000 hospital visits annually.

Installation

The V-PCOS mounts to North American 1-gang boxes, 3-1/2 inch or 4 inch octagon boxes, and to 4 inch square electrical boxes 1-1/2 inches (38 mm) deep. They also mount to European BESA and 1-gang boxes with 60.3 mm fixing centers. See mounting base installation and wiring for more information.

Testing & Maintenance

Each detector automatically identifies when it is dirty or defective and causes a "dirty detector" message. The detector's sensitivity measurement can also be transmitted to the loop controller. A sensitivity report can be printed to satisfy NFPA sensitivity measurements which must be conducted at the end of the first year and every two years thereafter.

The user-friendly maintenance program shows the current state of each detector and other pertinent messages. Single detectors may be turned off temporarily from the control panel. Availability of maintenance features is dependent on the fire alarm system used. When the CO sensor's electrochemical cell reaches its end of life, the detector signals a trouble condition to the control panel. The sensor/daughterboard module is field-replaceable. Scheduled maintenance (Regular or Selected) for proper detector operation should be planned to meet the requirements of the Authority Having Jurisdiction (AHJ). Refer to current NFPA 72, NFPA 720, and ULC CAN/ULC 536 standards.

This detector will NOT sense fires that start in areas where smoke cannot reach the detector. Smoke from fires in walls, roofs, or on the opposite side of closed doors may not reach the detector to alarm it.

Sensing and reporting technology

The microprocessor in each detector provides four additional benefits - Self-diagnostics and History Log, Automatic Device Mapping, Stand-alone Operation and Fast, Stable Communication.

Self-diagnostics and History Log - The V-PCOS constantly runs self-checks to provide important maintenance information. The results are automatically updated and permanently stored in the detector's non-volatile memory.

Automatic Device Mapping - The loop controller learns where each device's serial number address is installed relative to other devices on the circuit. The mapping feature provides supervision of each device's installed location to prevent a detector from being reinstalled (after cleaning etc.) in a different location from where it was originally.

Fast Stable Communication - On-board intelligence means less information needs to be sent between the detector and the loop controller. Other than regular supervisory polling response, the detector only needs to communicate with the loop controller when it has something new to report.

Accessories

Detector mounting bases have wiring terminals that are accessible from the "room-side" after mounting the base to the electrical box. The bases mount to North American 1-gang boxes and to 3½ inch or 4 inch octagon boxes, 1½ inches (38 mm) deep. They also mount to European BESA and 1-gang boxes with 60.3 mm fixing centers. The GSA-SB4, GSA-RB4, and GSA-IB4 mount to North American 4 inch sq. electrical boxes in addition to the above boxes. They include the GSA-TS4 Trim Skirt which is used to cover the "mounting ears" on the base. The GSA-SBT bases mounts to 4 inch sq. boxes only.



Remote LED GSA-LED - The remote LED connects to the GSA-SB or GSA-SB4 Standard Base only. It features a North American size 1-gang plastic faceplate with a white finish and red alarm LED.

GSA-TS4 Trim Skirt - Supplied with 4 inch bases, it can also be ordered separately to use with the other bases to help hide surface imperfections not covered by the smaller bases.

GSA-SBT - This sounder base is designed for use where localized or group alarm signaling is required. When used with the GSA-T3T4 Temporal Pattern Generator module, it adds an audible output function to the V-PCOS detector.

Typical Wiring

The detector mounting bases accept #18 AWG (0.75mm²), #16 (1.0mm²), #14 AWG (1.5mm²), and #12 AWG (2.5mm²) wire sizes.

Note: Sizes #16 AWG (1.0mm²) and #18 AWG (0.75mm²) are preferred for ease of installation. See the control panel reference manual for detailed wiring requirement specifications.

Standard Detector Base, GSA-SB, GSA-SB4

This is the basic mounting base for V-PCOS detectors. The GSA-LED Remote LED is supported by the Standard Base.

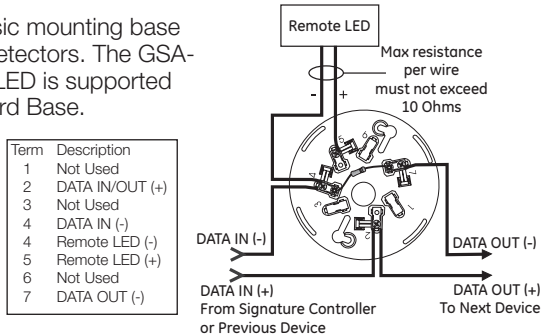

Isolator Detector Base, GSA-IB, GSA-IB4

This base includes a built-in line fault isolator for use on Class A circuits. A detector must be installed for it to operate. The isolator base does not support the GSA-LED Remote LED.

The isolator operates as follows:

- a short on the line causes all isolators to open within 23 msec
- at 10 msec intervals, beginning on one side of the Class A circuit nearest the loop controller, the isolators close to provide the next isolator down the line with power
- when the isolator next to the short closes, reopens within 10 msec.

The process repeats beginning on the other side of the loop controller.

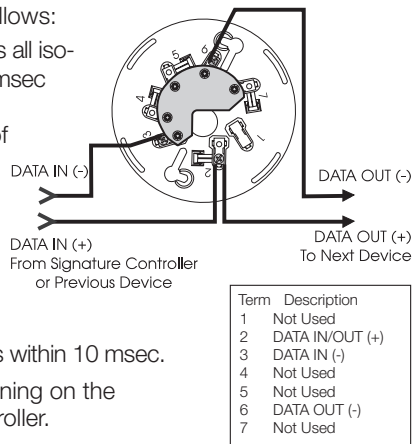

Relay Detector Base, GSA-RB, GSA-RB4

This base includes a relay. Normally open or closed operation is selected during installation. The dry contact is rated for 1 amp (pilot duty) @ 30 Vdc. The relay's position is supervised to avoid accidentally jarring it out of position. The GSA-RB can be operated as a control relay if programmed to do so at the control panel. The relay base does not support the GSA-LED Remote LED.

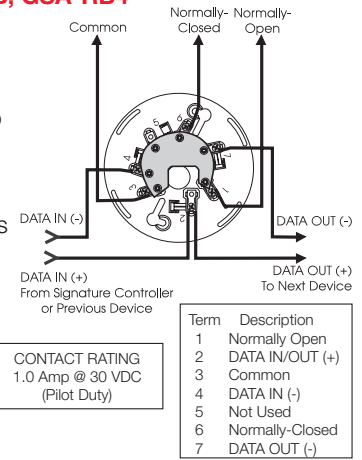

Audible Detector Base for CO and Fire Detectors, GSA-SBT

The GSA-SBT sounder base, when used with the GSA-T3T4 Temporal Pattern Generator, adds an audible output function to the V-PCOS detector. For more information on this device, refer to *Data Sheet M85001-0623 -- Sounder Base for CO and Fire Detectors*.

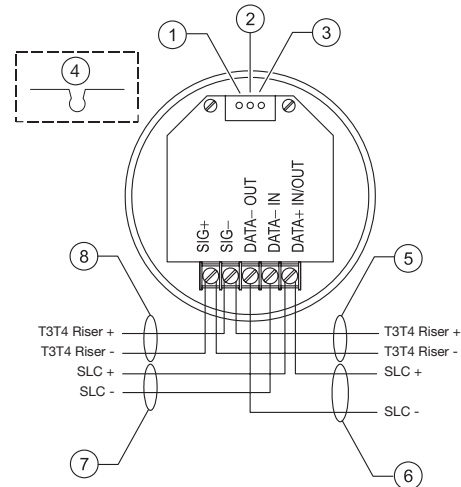

1. Volume setting. Default is high volume. For low volume, cut trace per item 4.
2. Reserved for future use. Do not cut.
3. Reserved for future use. Do not cut.
4. To configure output volume, cut trace as shown.
5. To next GSA-SBT sounder base or EOL relay.
6. SLC_OUT to next intelligent addressable device.
7. SLC_IN from intelligent addressable controller or previous device.
8. From GSA-T3T4 Temporal Pattern Generator or previous GSA-SBT sounder base.



Contact us...

Email: edwards.fire@fs.utc.com

Web: www.vigilant-fire.com

Vigilant is an **EDWARDS** brand.

1016 Corporate Park Drive
Mebane, NC 27302

© 2014 UTC Fire & Security Americas Corporation, Inc. All rights reserved. Specifications subject to change without notice. Edwards is part of UTC Climate, Controls & Security, a unit of United Technologies Corporation.

Warnings & Cautions

This detector will not operate without electrical power. As fires frequently cause power interruption, we suggest you discuss further safeguards with your fire protection specialist.

This detector will NOT sense fires that start in areas where smoke cannot reach the detector. Smoke from fires in walls, roofs, or on the opposite side of closed doors may not reach the detector to alarm it.

Specifications

Normal operating current	70 μ A
Alarm current	70 μ A
Operating voltage	15.20 to 19.95 VDC
Air velocity	0 to 4,000 ft./min (0 to 20 m/s).
Construction	High impact engineering polymer
Wall mounting	Maximum 12 in (305 mm) from ceiling
Mounting	Plug-in
Shipping weight	0.44 lb. (164 g)
Compatible bases	See Ordering Information
Operating environment	32 to 120°F (0 to 49°C), 0 to 93% RH, noncondensing
Storage temperature	-4 to 140°F (-20 to 60°C)
Environmental compensation	Automatic
UL Listed Spacing	30 ft (9.1 m)

Ordering Information

Catalog Number	Description	Ship Wt. lbs (kg)
V-PCOS	Intelligent Photoelectric Detector with carbon monoxide sensor	0.4 (0.16)
V-PCOS-CA	Intelligent Photoelectric Detector with carbon monoxide sensor (for use in Canadian markets only).	0.4 (0.16)

Accessories		
GSA-SB	Detector Mounting Base - Standard	
GSA-SB4	4-inch Detector Mounting Base c/w Trim Skirt	
GSA-RB	Detector Mounting Base w/Relay	
GSA-RB4	4-inch Detector Mounting Base w/Relay, c/w Trim Skirt	0.2 (.09)
GSA-IB	Detector Mounting Base w/Fault Isolator	
GSA-IB4	4-inch Detector Mounting Base w/ Fault Isolator, c/w Trim Skirt	
GSA-LED	Remote Alarm LED (not for EN54 applications)	
GSA-SBT	Audible (Sounder) Base for CO and Fire Detectors	0.3 (0.15)
GSA-T3T4	Temporal Pattern Generator	0.3 (0.15)
GSA-TS4	Trim Skirt (supplied with 4-inch bases)	0.1 (.04)
2-SPRC2	Replacement Smoke Chamber (for V-PCOS detectors)	0.1 (.04)
2-CORPL	Replacement CO Sensor	0.1 (.04)