

ILI Series

Intelligent Ionization Smoke Detectors for IXL, MXL, and XL3 Control Panels

ENGINEER AND ARCHITECT SPECIFICATIONS

ILI-1, ILI-1A, ILI-1B, ILI-1H, ILI-1AH, ILI-1BH

- On-Board Motorola Microprocessor Based Design
- Innovative Technology Provides High Speed, Fault Tolerant System/Detector Communications
- EEPROM Supervision; Protects Critical Detector Programming
- Highly Resistant to RFI, EMI and Humidity
- Remote Sensitivity Adjustment and Measurement Capability
- Alarm Indicator LED
- Two Wire Operation
- Compatible with **SensorLINK**, model FPI-32 or DPU Field Programmer/Tester: Program /Verify Detector Addressing, Perform Diagnostic Testing of Detectors
- EnviroLINK; Software Based Automatic Environmental Compensation (available only when used with MXL Series systems)
- Optional, Fully Programmable Relay Base and Audible Base
-  Listed, ULC Listed, FM, CSFM, and NYMEA Approved



Introduction

Siemens Building Technologies, Fire Safety Division ILI-1, ILI-1A, ILI-1B, ILI-1H, ILI-1AH, ILI-1BH intelligent ionization smoke detectors offer the fire and life safety industry the most advanced method of detection, programming and communications available today. Additionally, the ILI Series detectors provide an extremely high degree of resistance to RFI, EMI and humidity. The ILI Series ionization detector utilizes a state-of-the-art Motorola microprocessor with "on-board" EEPROM. The microprocessor provides the power to operate the detector's sophisticated detection, error checking and supervision algorithms.

The ILI Series intelligent ionization detectors are compatible with Fire Safety **SensorLINK** FPI-32 or DPU field programmer/tester. The FPI-32 is a compact, portable, menu-driven accessory which makes programming and testing detectors faster, easier and more reliable than other methods. The FPI-32 eliminates the need for cumbersome, unreliable mechanical programming methods and reduces installation and service costs by electronically programming addresses and functionally testing the ILI's performance before the detector is installed.

The ILI Series ionization detectors are also compatible with Fire Safety IXL, MXL and XL3 control panels.

All ILI Series detectors are Underwriters Laboratories Listed.

Description

The ILI-1, ILI-1A, ILI-1B, ILI-1H, ILI-1AH, ILI-1BH are plug-in, two-wire ionization detectors, compatible with Fire Safety IXL, MXL and XL3 control panels. The ILI Series ionization detectors consist of self-compensating dual ionization chambers and highly stable solid state electronic circuitry.

The outer chamber of the detector's self-compensating dual ionization chambers detects the presence of products of combustion. The inner chamber serves as a reference to stabilize the detector's sensitivity to gradual changes in environmental conditions. Also, the detector's microcomputer chip software compensates for ambient temperature changes. As a result, temperature and humidity changes have a minimal effect

on the detector's sensitivity within the detector's specified operating range.

The detector's microcomputer chip has the capacity of storing, in memory, identification information as well as important operating status information such as assigned alarm threshold and trouble threshold values. In addition, the ILI Series detectors using their microcomputer chip, can communicate in either of two protocols. One protocol type is used when the ILI Series detectors communicate with the MXL and IXL control panels and the other protocol is used for XL3 communication.

If the ILI Series detectors are linked to an MXL or IXL (ICon) panel, whether the detector's operating status is normal or in alarm or trouble depends upon the difference between the alarm threshold value stored in the detector's memory and the detector's analog value. The detector then communicates its operating status to the control panel.

In addition, the MXL periodically obtains the signal of the detector's analog value. When the MXL determines that the detector's analog values indicate excessive dust build-up, the MXL informs the user that the particular detector requires maintenance.

When the ILI Series ionization detector's alarm condition is confirmed by the control panel, the detector's LED blinks and continues blinking until the system is reset at the control panel. Also any user defined system alarm function and control by event functions are activated when the detector goes into alarm. Each ILI Series ionization detector is capable of operating one I Series remote alarm indicator or one auxiliary relay or one audible base.

Detector sensitivity, calibration and identification are dynamically supervised by the control panel. Detector sensitivity can be changed from the control panel.

A **SensorLINK**, Model FPI-32 and DPU Programmer/Tester are used to program and verify each detector's address. The user selects the Program Mode to enter the desired address. The Programmer/Tester then automatically sets and verifies the address as well as tests the detector. The Programmer/Tester has rechargeable batteries, so each detector's address can be programmed by the user from the most convenient location. The user can also separately test the detector for functionality. When the user selects the Test Mode, a series of tests are automatically conducted and the user is informed whether the detector has passed or failed.

The ILI Series are fully compatible on the same MXL circuit with other IL Series detectors, MSI Series manual stations, TRI-60 Series interfaces or the CZM Series addressable conventional zone modules. The ILI Series are fully compatible on the same IXL (ICon) circuit with other IL Series detectors, MSI manual stations and TRI-60 interface modules. The ILI Series

are also fully compatible on the same XL3 circuit with all X Series detectors, manual stations or interface modules.

The ILI Series detectors use a low profile, surface mounting base, Model DB-3S which mounts to a 4 inch octagonal, square or single gang electrical box. Relay base Model DB-X3RS mounts to a 4 inch square deep electrical box. Audible base Model ADBI-60 also mounts to a 4 inch square deep electrical box. When a 4 inch square or 4 inch square deep box is used, an optional finish ring for these bases is available, Model RA-ADB.

The DB-3S, DB-X3RS and ADBI-60 bases use screw-clamp terminals for all electrical connections and self-wiping contacts for reliability. The bases also contain a provision for an optional concealed locking mechanism to prevent unauthorized removal of the detector head, Model DB-LK.

The ILI Series ionization detectors are designed to meet a wide range of system design parameters. The ILI is designed to be used in areas which have minimal air velocities of up to 300 ft./min. The ILI-1A is designed for open area protection and plenum protection where the air velocity is 0-1200 ft./min., such as, under floor areas in computer rooms. The ILI-1A has a specially designed internal chamber cover to provide the detector with the stable operation needed for this type of service.

The ILI-1B is designed specifically for use with Fire Safety AD-3I air duct detector housing, and, like the ILI-1A, contains a specially designed internal chamber cover. The ILI -1B must be used with the AD-3I air duct detector housing in air duct applications with air velocities of 500-4000 ft./min. If a relay is desired, use a DA-X3SR module with the AD-3I housing.

The ILI-1, ILI-1A and ILI-1B are also available for use in high altitude applications (3000 to 8000 feet above sea level) designated as model numbers ILI-1H, ILI-1AH and ILI-1BH.

This equipment is approved for operation over the temperature range of 0°C and 38°C.

Application Data

An XL3's INX input module contains four circuits, with each circuit capable of supporting up to thirty ILI Series intelligent ionization detectors. The MXL uses ALD loop circuits with each circuit capable of supporting up to sixty ILI Series ionization detectors. The IXL uses an ICon module and each ICon module is capable of supporting sixty ILI Series intelligent ionization detectors.

The ILI ionization detectors are applicable to the maximum 30 foot center spacing (900 sq. ft.) as referred to in the National Fire Protection Association Standard 72. This, however, is based on ideal conditions, namely, smooth ceiling, no air movement and no physical obstructions between the fire source and the

detector. This spacing should be used as a guide or a starting point in detector installation layout. Do not mount detectors in areas close to ventilation or air conditioning outlets. Exposed joists or beamed ceilings may also affect safe spacing limitations for detectors. It is mandatory that engineering judgment be applied regarding detector locations and spacing. Should questions arise regarding detector placement, follow NFPA 72 guidelines.

The detector, or group of detectors, require a two-wire circuit of 18 AWG thermoplastic fixture wire enclosed in conduit, or 18 AWG, limited energy, shielded cable without conduit if permitted by local building codes. Wiring should conform to local and National Electrical Codes and to the control panel's wiring specifications. T-tapping is permitted only for Style 4 (Class B) wiring.

Engineer and Architect Specifications

The addressable ionization detector shall incorporate a custom microprocessor based integrated circuit which shall provide communication with its compatible control panel. All of the detector's communication circuits shall be contained within the detector. No communication electronics or address identification mechanisms shall be contained within the detector's base. The detector shall be a Fire Safety ILI Series ionization detector which shall be compatible with a Fire Safety XL3, MXL Series, or IXL control panel. The ionization detector shall be a plug-in unit which mounts to a twist-lock base. The detector shall operate on a two wire circuit and shall contain an LED which shall blink to signal alarm actuation. The detector shall be Underwriters Laboratories, Inc. listed.

The detector shall contain two ionization chambers and an LED alarm indicator. The reference chamber and the microcomputer chip's software shall compensate against sensitivity changes caused by environmental factors such as temperature, humidity and barometric pressure.

The detector's address shall be programmed with the use of a portable programming accessory. The programming accessory shall be a Fire Safety FPI-32 or DPU Programmer/Tester. The portable programmer shall be menu driven. Once the desired address is entered, the programmer shall set and verify the address. The programming accessory shall also be capable of testing the detector's functionality. The detector's address shall be set by electronic means only. No mechanical means such as programming pins, DIP switches or rotary dials shall be required to set the detector's address.

The detector shall be capable of bidirectional communication with the control panel.

The detector shall be dynamically supervised and uniquely identifiable by the control panel. The control panel shall be capable of analyzing the signal of the detector's analog value for calibration, identification and sensitivity. These values can be displayed by the control panel and monitored for processing according

to control panel instructions. The detector's sensitivity shall be individually adjustable from the control panel. Should the detector sensitivity voltage shift beyond an acceptable level and stay there for a predetermined length of time, a discrete detector trouble signal shall be annunciated at the control panel.

The detector shall be compatible on the same MXL circuit with all other Fire Safety "I" Series detectors, manual stations, TRI Series interface modules, or CZM Series addressable conventional zone modules. The detector shall be compatible on the same IXL circuit with all other "I" Series detectors, manual stations and TRI Series interface modules.

The detector shall be capable of operating one remote alarm indicator or auxiliary relay or audible base. The relay or remote alarm indicator is normally activated by the associated detector. However, the MXL or XL3 system shall be capable of being programmed to operate the relay or remote alarm indicator independently of the associated detector. All detectors and/or relays connected to the circuit can be in alarm or activated simultaneously.

The addressable ionization detectors shall insert into the standard Model DB-3S base or the ADBI-60 audible base or DB-X3RS relay base. The base assembly in which the detector is installed shall be of the twist-lock design with screw-clamp terminals. The base shall use self-wiping contacts and shall accept other compatible plug-in detectors. A locking mechanism shall be installed in those areas where tamper resistant installation is required.

The detector shall be the Fire Safety ILI-1 for applications which have minimal air flow (0-300 ft./min.), the ILI-1A for applications with high air velocity (0-1200 ft./min.), or the ILI-1B for applications that involve air ducts and the use of the AD-3I air duct detector housings.

The detector shall also be available for applications in altitudes of 3000 to 8000 feet above sea level if desired.

In this application the detector shall be the Model ILI-1H, ILI-1AH or ILI-1BH.

Technical Specifications

Current Requirements: Normal - 1.2mA Typical
Alarm - 1.5mA Typical

Voltage Range: *16VDC - 30VDC
Peak Pulsed Voltage

Operating Temperature: +32°F (0°C) to +100°F
(38°C) per UL 268/268A

Humidity: 0-93% Relative Humidity
Non-Condensating

Mounting Data

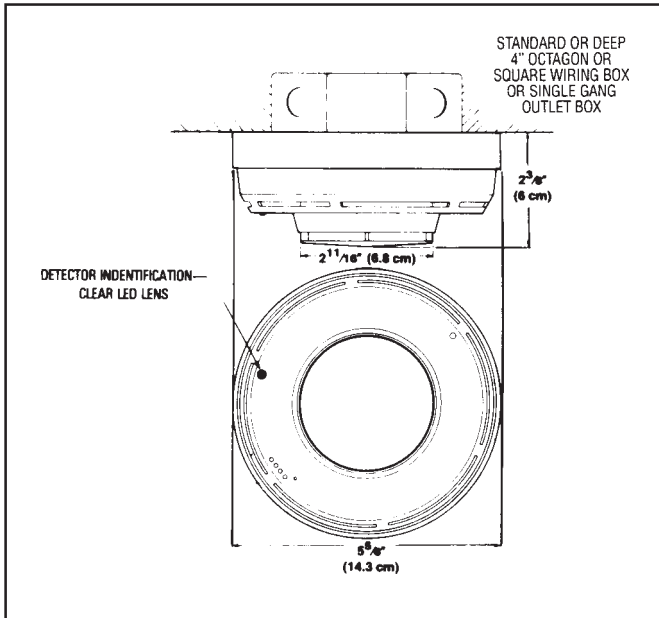

Ordering Information

Model	Description	Shipping Wt.	
		Lb.	Kg.
ILI-1	Addressable ionization detector air flow (0-300 ft./min.)	1	.45
ILI-1H	Addressable ionization detector air flow (0-300 ft./min.) High altitude (3000-8000 ft.)	1	.45
ILI-1A	Addressable ionization detector air flow (0-1200 ft./min.)	1	.45
ILI-1AH	Addressable ionization detector air flow (0-1200 ft./min.) High altitude (3000-8000 ft.)	1	.45
ILI-1B	Addressable ionization detector air duct use only (with AD-3I)	1	.45
ILI-1BH	Addressable ionization detector air duct use only (with AD-3I) High altitude (3000-8000 ft.)	1	.45
DB-3S	Low profile mounting base	1	.45
DB-X3RS	Mounting base with relay	1	.45
ADBI-60	Audible base	1	.45
DB-LK	Locking kit for Series 3 base	.5	.22
RA-ADB	Optional finish ring for bases	.2	.1
RLI-1	Remote alarm indicator (for 4" octagon box mounting)	1	.45
RLI-2	Remote alarm indicator (for switch box mounting)	1	.45
AD-3I	Air Duct Housing	6	2.7
DA-X3SR	Duct Relay Module	.5	.22

Wiring Diagram

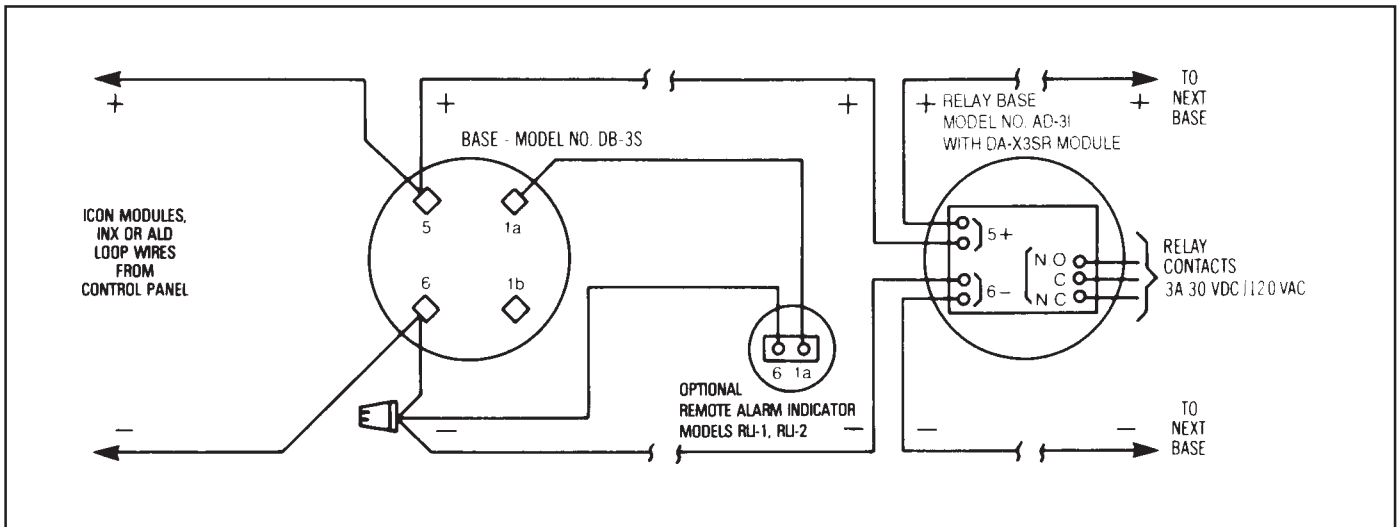

NOTICE: The use of other than Fire Safety detectors and bases with Fire Safety equipment will be considered a misapplication of Fire Safety equipment and as such voids all warranties either expressed or implied in regard to loss, damage, liabilities and/or service problems.