

Model 8802/03/04 Intelligent Modules for Contact Devices

Features

- Interfaces and Supervises Normally Open
- Integral SPDT Relay (up to 4 amps) on 8804
- Dual Input on 8803
- Multi-color L.E.D. indicates status (green, amber, red)
- Easy front access to programming port and wiring terminals
- Mounts in 4" square x 3-3/4" deep box, or double gang, 3-1/2" deep box
- Dynamic supervision
- Comes with 5" x 5" faceplate
- Style "B" class B IDC wiring
- Model 8820 programs and verifies device's address and tests device's functionality
- Electronic address programming is easy and dependable
- UL listed, CFSM and NYMEA pending

Description

The Faraday intelligent interface modules are available in three models. The 8802 and 8804 are designed to monitor a normally open dry contact. The interface module reports the contact's status to the control panel. The 8802 model can only monitor and report the status of the contact, while the 8804 incorporates an addressable Form C relay. The 8804 relay and contact device input are controlled at the same address. For the MPC-Plus system, the relay and input contact can be controlled as a separate function. The relay is typically used where control or shunting of external equipment is required.

The 8803 is a dual input module and is designed to supervise and monitor two sets of dry contacts. This interface module requires two address settings. The 8803 is ideal for monitoring a waterflow switch and its respective valve tamper switch.

These devices have a multi-color Light Emitting Diode that flashes green when operating normally, amber if unit is in trouble condition, and red to indicate a change of state. The 8803 flashes twice, once for each address, the 8804 red L.E.D. indicates a change of state in the relay.

The device's microcomputer chip has the capacity of storing, in memory, identification information as well as important operating status information.

All intelligent interface modules to be programmed by using the model 8820 Programmer/Tester. The 8820 Programmer/Tester is a compact, portable, menu



Model 8802

driven accessory that makes programming and testing an interface device faster, easier and more dependable than previous methods.

Engineer and Architect Specifications

The addressable interface module shall incorporate a custom microprocessor based integrated circuit that shall provide communication with its compatible control panel. The addressable interface module shall be a Faraday 880x Series that shall be compatible with a Faraday, MPC-Plus control panel. These intelligent interface modules shall provide the means of interfacing direct shorting devices to the control panel's addressable circuits. The intelligent interface modules shall be available in three models. The 8802 and 8804 shall be designed to monitor a single normally open or normally closed dry contact. The interface module shall report the contact's status to the control panel. The 8802 model shall only monitor and report the status of the contact, while the 8804 shall incorporate an addressable form C relay. The 8804 relay and contact device input shall be controlled as a separate function at the same address by the MPC-Plus control panel. The 8803 shall be a dual input module designed to supervise and monitor two sets of dry contacts. This interface module shall require two address settings.

Modules shall have tri-color LED indicating status of the unit, indicating green in normal conditions, amber if the unit is malfunctioning, and red when it changes state.

... continued

The addressable interface module shall be UL listed.

The addressable interface module shall be dynamically supervised and uniquely identifiable by the control panel.

The addressable interface module's address shall be programmed with the use of a portable programming accessory. The programming accessory shall be a Faraday 8820 Programmer/Tester. The portable programmer shall be menu driven. Once the desired address is entered the programmer shall set and verify the address. The programming accessory shall

also be capable of testing the interface's functionality. The addressable interface module's address shall be set by electronic means only. No mechanical means such as programming pins, DIP switches or rotary dials shall be required.

This series shall be compatible on the same MPC-Plus circuit with other Faraday intelligent detectors, addressable interfaces, addressable manual stations or any other Faraday addressable intelligent modules.

Typical Wiring

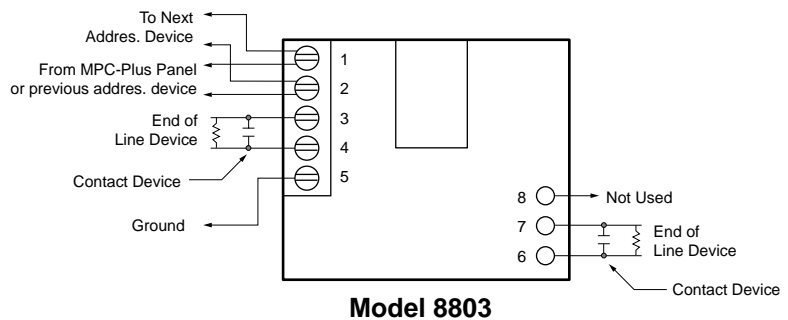
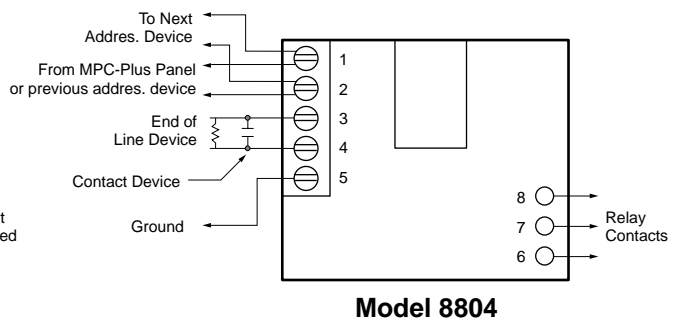
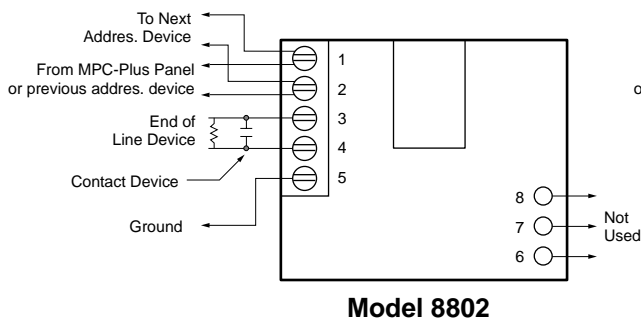

Ordering Information

Order No	Spec Sheet	Description
8802		Single input contact device
8803		Dual input contact device
8804		Single input w/relay

Accessories

8820	FAI-104	Programmer/Tester
8986	FAI-104	Carrying case for 8820



805 South Maumee Street
 Tecumseh, MI 49286, U.S.A.
Phone: (800) 465-7115
Fax: (800) 552-3557
Web: www.faradayllc.com

WARNING - The information contained in this document is intended only as a summary and is subject to change without notice. The devices described in this document have specific instruction sheets which cover various technical, limitation and liability information. Copies of these instruction sheets and the General Product Warning and Limitations Document, which also contains important information, are provided with the product and are available from the Manufacturer. Information contained in these documents should be consulted before specifying or using the product. For further information or assistance concerning particular problems contact the Manufacturer.