



November 30, 1998

G-125

Gentex GMH/GMS Series 4" Electro-Mechanical Horns & Horn/Strobes

Section: Audio/Visual Devices

STANDARD FEATURES

- Low-frequency penetrating sound output.
- Low operating current.
- Screw terminals, separate in/out field wiring (12 AWG/ 3.25 mm²).
- Textured plastic high-impact faceplate.
- Separate horn and strobe functions (jumper wires).
- Variety of standard mounting options.
- Supplied with beauty plugs to accommodate mounting option.
- Strobe maintains constant flash rate regardless of input voltage.
- Flush mounting.
- Outdoor use listed (GMH and WGMS).
- 15/75, 30/75 and 110 candela strobe options meet or exceed the requirements of ADA 4.28.3.
- UL 464/UL1971 listed for fire protection service/signal for hearing impaired.
- No mechanical contacts.
- Flash rate 1 Hz (60 flashes per minute).

APPLICATIONS

This Gentex 4" low-frequency electromechanical horn/strobe series meets and exceeds code requirements for supervised fire alarm systems for the hearing impaired.

The GMH/GMS Series are quality electromechanical signaling appliances that offer both dependable evacuation signals and visual alarms by means of simple screw-terminal wiring connections.

The GMH/GMS Series is designed to be used for both new construction and retrofit projects. With the Gentex trim ring, the GMH/GMS can be mounted to a double-gang work box in retrofit or new construction.

GMH/GMS devices are suited for areas having high ambient noise levels where higher audible output is required. Z Series synchronized strobes require the use of the ZMS4 module.

The GMH/GMS appliances are UL 464 and UL 1971 listed for use with fire protective signaling systems. GMH/GMS are warranted for two years from the date of purchase.

ARCHITECTS' & ENGINEERS' SPECIFICATIONS

The alarm signal shall be Gentex model GMH or GMS or approved equivalent, and shall be listed by Underwriters Laboratories per UL 464, and when combined with the strobe option, the strobe shall also be listed per UL 1971. The notification appliance shall also be listed with the California State Fire Marshal (CSFM) and MEA (NYC).



LISTED
S5405, S3406
S3834



California
State Fire
Marshal

7135-0569:119



CS607 (GMH24R,
GMS24-15WR,
GMS24-1575R,
GMS24-3075WR)

MEA

285-91-E Vol. VII

Complies with:

- NFPA 72
- ADA 4.28.3 (15/75, 30/75, 110 cd)

City of Chicago

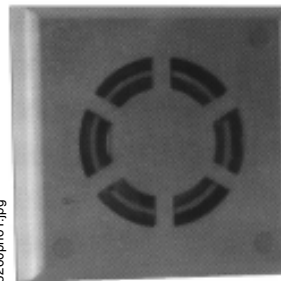

GMH-24



GMS-24

5260photo1.jpg

The notification appliance shall produce a peak sound output of 105 dBA or greater as measured in an anechoic chamber.

The visual signal shall have a flash rate of 1 Hz regardless of input voltage.

The notification appliance shall be provided with screw terminals for in-and-out field wiring and the strobe shall be capable of operating independently after the audible has been silenced.

The notification appliance shall be capable of mounting to a 4" (10.16 cm) square backbox and a two-gang switch box with the Gentex trim ring.

This document is not intended to be used for installation purposes. We try to keep our product information up-to-date and accurate. We cannot cover all specific applications or anticipate all requirements. All specifications are subject to change without notice. For more information, contact Fire-Lite Alarms, One Fire-Lite Place, Northford, Connecticut 06472. Phone: (800) 627-3473, Toll Free FAX: (877) 699-4105, FAX Back:(888) 388-3299
WEB: www.firelite.com



AVAILABLE MODELS			STROBE RATED CURRENT			
	Model Number	Horn Appliance Operating Voltage	Light Effective Intensity in Candela	Nominal Operating Current	Inrush*	Peak
GMH24R	24 VDC		(horn 38 mA)			105
GMS24-15WR	24 VDC	15	78 mA	114 mA	84 mA	105
GMS24-1575WR	24 VDC	15 or 75	105 mA	130 mA	110 mA	105
GMS24-30WR	24 VDC	30	105 mA	130 mA	110 mA	105
GMS24-3075WR	24 VDC	30 or 75	142 mA	120 mA	160 mA	105
GMS24-60WR	24 VDC	60	115 mA	140 mA	120 mA	105
GMS24-110WR	24 VDC	110	220 mA	148 mA	240 mA	105
GMS24-1575CR	24 VDC	15 or 75	115 mA	140 mA	120 mA	105
GMS24-1575WRZ (or WWZ)	24 VDC	15 or 75	130 mA	490 mA	680 mA	105
WGMS24-75WR (or CR)	24 VDC	75	105 mA	130 mA	110 mA	105

NOTES: *INRUSH CURRENT: for less than 0.2 micro seconds. ALL 24 VDC MODELS operate from 21-30 VDC -20%/+10%. OPERATING TEMPERATURE: *INDOORS:* 32°F to 120°F (0°C to 49°C); *OUTDOORS:* -31°F to 150°F (-35°C to 66°C). CANDELA: light effective intensity in candela 15/75 or 30/75 per UL 1971 15 or 30) and UL 1638 (75). **WHEN PLACING AN ORDER:** The following letters are used at the end of the model number: "W" (WALL mount), "C" (CEILING mount, certain 75 or 15/75 models only); either "R" at end (RED faceplate), or "W" at end (OFF-WHITE faceplate); "Z" (Z Series synchronized strobe, 15/75 models only) last on applicable models. **MODELS ARE WALL-MOUNT ONLY, EXCEPT "C" MODEL NOS.**

WIRING DIAGRAMS

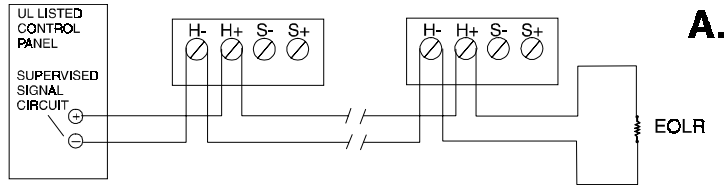

A.

A. GMH Horn and GMS Series powered IN PARALLEL.

B. GMS Series with horn and strobe powered INDEPENDENTLY. NOTE: REMOVE CIRCUIT COVER HOUSING AND CUT JUMPERS 1 AND 2.

GENERAL NOTE: POWER IS SUPPLIED TO DEVICES WHEN CONTROL PANEL IS LATCHED.

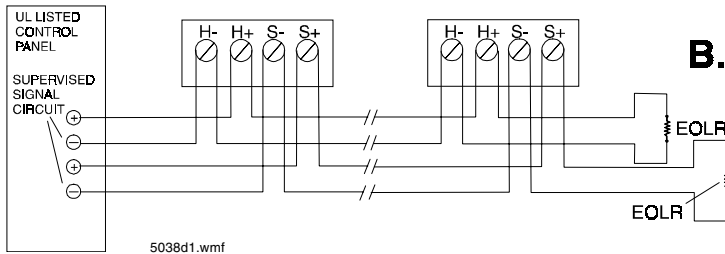

B.

MOUNTING EXAMPLES

- 4" (10.16 cm) square boxes with brackets 2-1/8" (5.3975 cm) deep minimum.
 - 4" (10.16 cm) square metal/nonmetallic switch/outlet boxes 2-1/8" (5.3975 cm) deep minimum.
 - Gangable two-gang switch/masonry outlet boxes 2-1/8" (5.3975 cm) deep minimum (with trim plate).
- NOTE:** Supplied with beauty plugs to accommodate a variety of installations.

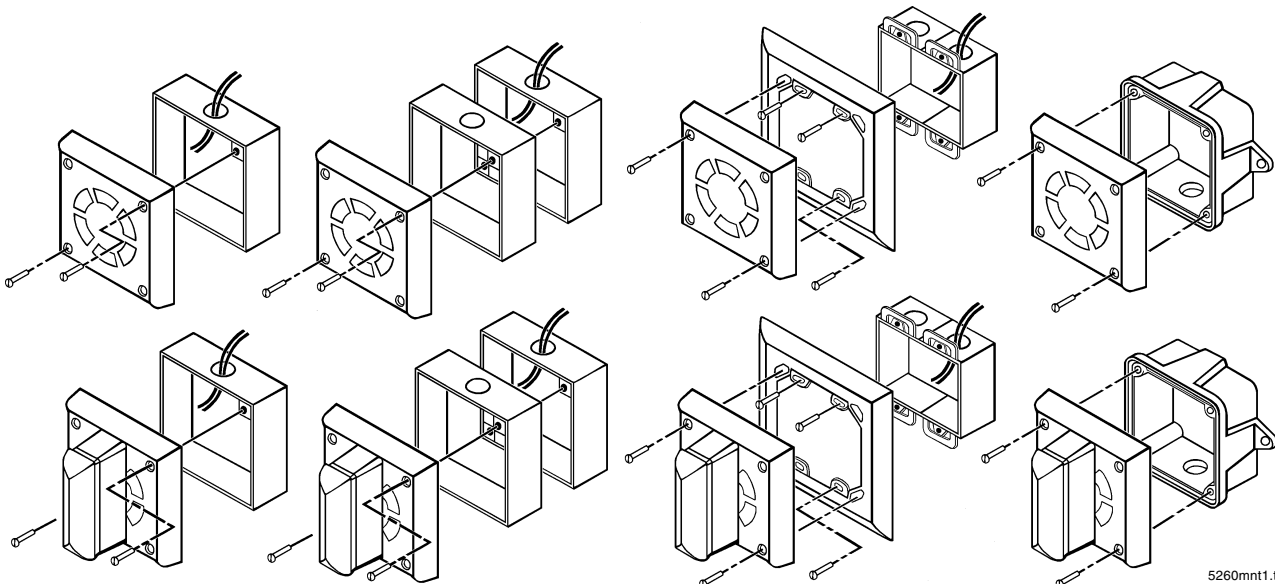

5260mnt1.tif