

ILI-MB-E3

Intelligent Loop Interface-Main Board Product Installation Document

**CAUTION: STATIC SENSITIVE EQUIPMENT**

THIS EQUIPMENT IS SENSITIVE TO STATIC ELECTRICITY. IT MAY BE DAMAGED IF NOT PROPERLY HANDLED. TRANSPORT AND STORE THIS UNIT IN A STATIC-SHIELDING BAG. FAILURE TO OBSERVE THIS REQUIREMENT COULD CAUSE LATENT DAMAGE TO THE EQUIPMENT WHICH MIGHT NOT MANIFEST ITSELF UNTIL AFTER THE EQUIPMENT IS PLACED IN SERVICE.

**CAUTION: DISCONNECT ALL POWER**

REMOVE ALL SOURCES OF POWER BEFORE SERVICING, REMOVING OR INSTALLING ANY UNITS.

Section 1: Description

The ILI-MB-E3 (Intelligent Loop Interface-Main Board) is the main circuit board. When the ILI-MB-E3 is connected to the network, it is compatible with the following systems.

- E3 Series[®] Fire Alarm and Mass Notification System (Autonomous Control Unit)
- E3 Series (Expandable Emergency Evacuation) System
- E3 Series Broadband System
- E3 Series Classic System (for Fire applications only)



NOTE: The E3 Series nodes may be networked with the S3 Series System.

It provides terminals for the connection of all of the sub-assemblies. The ILI-MB-E3 sub-assembly can support the following modules:

- up to a total of 16 ASM-16 and/or
- up to a total of 16 ANU-48 Remote LED Driver Modules
- DACT-E3
- LCD-E3 or LCD-SLP

The ILI-MB-E3 supports the System Sensor protocol using Velociti[®] mode. In Velociti mode, each Signaling Line Circuit (SLC) supports 159 detectors and 159 modules. When the unit is used in conjunction with the RPT-E3-UTP Repeater sub-assembly, J2, and/or J5 connected, each unit occupies one node on the Broadband network. Figure 1.1 illustrates the ILI-MB-E3 (First Generation) module, and Figure 1.2 illustrates the ILI-MB-E3 (Second Generation) module.



NOTE: Use the Signaling Line Circuit (SLC) devices for Fire and/or E3 Series Releasing applications.

ILI-MB-E3 (First Generation)



Figure 1.1 ILI-MB-E3 (First Generation) Module

ILI-MB-E3 (Second Generation)

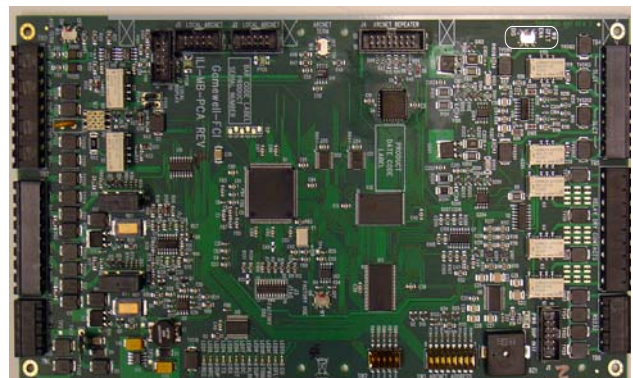

Figure 1.2 ILI-MB-E3 (Second Generation) Module

1.1 Mass Notification System (MNS)

The Gamewell-FCI, Mass Notification System (MNS) is a Combination In-Building Fire and Mass Notification System. It comprises the E3 Series Broadband Emergency Voice Evacuation and the E3 Series Broadband Networked Fire Alarm Systems. This design allows a wide range of configurations to form an integrated, distributed fire alarm system in combination with the audio evacuation for both Fire and Mass Notification functions as desired. The design also allows for its use as a dedicated standalone Mass Notification System without the fire alarm service. The network communication conveys all Fire Alarm and Mass Notification control functions, audio evacuation, voice paging, and fire fighter communications over a single pair of wires or fiber-optic cable. The modular design offers several configurations to accommodate the following audio components:

- Autonomous Control Unit (ACU), (Main Command Center)
- Local Operating Console (LOC), (Remote Command Center)
- E3 Series Broadband Voice Evacuation System

Table 1.1.1 lists the E3 Series sub-assemblies that can be used in the Gamewell-FCI, MNS (Mass Notification System).

Autonomous Control Unit (ACU) (Main Command Center)	E3 LOC Remote Command Center	E3 Broadband System (Distributed System)
AM-50 Series Amplifiers	AOM-TELF/AOM-2SF	AM-50 Series Amplifiers
ANU-48 (Remote Annunciator)	ASM-16 (Addressable Switch Module)	ANU-48 (Remote Annunciator)
ASM-16 (Addressable Switch Module)	INI-VG Series (First/Second/Third Generation) (Intelligent Network Interface Voice Gateway)	ASM-16 (Addressable Switch Module)
ILI-MB-E3 (Intelligent Loop Interface-Main Board)	INCC-MIC (Microphone)	ILI-MB-E3 (Intelligent Loop Interface-Main Board)
ILI-S-E3 (Intelligent Loop Interface-Expansion Board)	NGA (Network Graphic Annunciator)	ILI-S-E3 (Intelligent Loop Interface-Expansion Board)
ILI95-MB-E3 (Intelligent Loop Interface-Main Board)	INCC-TEL (Telephone)	ILI95-MB-E3 (Intelligent Loop Interface-Main Board)
ILI95-S-E3 (Intelligent Loop Interface95-Expansion Board)		ILI95-S-E3 (Intelligent Loop Interface95-Expansion Board)
INCC-MIC (Microphone)		INCC-MIC (Microphone)
INCC-TEL (Telephone)		INCC-TEL (Telephone)
INI-VG Series (First/Second/Third Generation) (Intelligent Network Interface Voice Gateway)		INI-VGC, (First/Second/Third Generation) (Intelligent Network Interface Voice Gateway)
NGA (Network Graphic Annunciator)		INI-VGX, (First/Second/Third Generation) (Intelligent Network Interface Voice Gateway)
PM-9/PM-9G (Power Supply)		NGA (Network Graphic Annunciator)
RPT-E3-UTP (Communication Circuit)		PM-9/PM-9G (Power Supply)
		RPT-E3-UTP (Communication Circuit)

NOTE 1: In the E3 Series, Mass Notification System, the LCD-E3 and LCD-SLP Display panels are not used.

Table 1.1.1 E3 Series Modules Used in the MNS System

1.1.1 Mass Notification System - Documentation

The following MNS System information is available in the Gamewell-FCI, *Mass Notification System (MNS) Installation/Operation Manual, Part Number:LS10013-000GF-E*.

- System Configurations
- Cabinets Installations
- Class 2 Power-Limited Requirements
- Wiring
- System Operation
- Testing/Maintenance

E3 Series[®] and Velocit[®] is a registered trademark and CAMWorks[™] is a trademark of Honeywell International Inc.
 UL[®] is a registered trademark of Underwriters Laboratories, Inc.
 ©2018 Copyright by Honeywell International, Inc. All rights reserved.

Section 2: Installation

2.1 Standards

The ILI-MB-E3 module complies with the following standards:

- **Compliance** - This product has been investigated and found to be in compliance with the following standards.

National Fire Protection Association

- NFPA 72 National Fire Alarm Code

Underwriters Laboratories

- UL-864 Control Units for Fire Alarm Systems, Ninth Edition
- UL-2017 General Purpose Signaling Devices and Systems, First Edition
- UL-2572 MNS Mass Notification, First Edition

- **Installation** - This product is intended to be installed in accordance with the following standards.

National Fire Protection Association

- AHJ Authority Having Jurisdiction
- NFPA 70 National Electrical Code
- NFPA 72 National Fire Alarm Code
- NFPA 101 Life Safety Code

2.2 Installation Requirements

All components of the E3 Series[®] System should be installed per the following requirements:

- Installations are to be indoors only, in dry locations, protected from rain, water, and rapid changes in temperature that could cause condensation. Equipment must be securely mounted on rigid, permanent walls.
- Operating temperature shall not exceed the range of 32° to 120° F (0 to 49° C).
- Operating humidity not to exceed 93% non-condensing at 90° F (32° C).
- There should be adequate space around the installation to allow easy access for operation and servicing.
- All sub-assemblies and components are to be located in compliance with the local and the national codes.
- All installation field wiring shall be in compliance with the local, the national codes and the manufacturer’s recommendations.
- Use the Architects and Engineering Specifications for detailed information on your facility’s configuration.
- Installers must be Gamewell-FCI Factory Certified to program this product. For additional information on this product, contact the Gamewell-FCI Customer Support to schedule the Factory Certified Training.



IMPORTANT NOTE: COLD WATER/EARTH GROUND STANDARD:

Per Article 760 of the National Electrical Code, the following terminal blocks must be connected to an Earth Ground connection:

- Terminal TB3-3 on the ILI-MB-E3/ILI95-MB-E3
- Terminal TB3-3 on the INI-VG Series (First/Second Generation)
- Terminal TB1-5 on the INI-VG Series (Third Generation)

Failure to make a proper earth ground connection from a metallic cold water pipe or driven ground rod to this terminal will result in loss of lightning protection, reduce the tolerance of the system to transients, and will adversely affect the operation of the system. Panel neutral or conduit ground is not acceptable; minimum wire size is 14 AWG.

2.3 Specifications

The following list the electrical specifications for the ILI-MB-E3.

Operating Voltage	24 VDC (from the PM-9/PM-9G power supply)
Operating Current:	0.081 amp
Alarm Current:	0.150 amp
Operating Temperature:	32° to 120° F (0° to 49° C)
Relative Humidity:	0 to 93%, non-condensing at 90° F (32° C) to 93% non-condensing at 90° F (32° C)
Supervised	
Class 2 Power-Limited	

2.4 ILI-MB-E3 Installation Assembly Options

Table 2.4.1 lists the cabinet configurations that the ILI-MB-E3 can be installed. To determine which configuration to install the ILI-MB-E3 module, identify the System your facility uses. Then, locate the configuration in the Cabinet Assembly Options column. To locate the Section that describes how to install the ILI-MB-E3 in the appropriate configuration, refer to the Installation Instructions column.

For example, if your facility uses an E3 Series System, and your facility purchased the Cabinet B, refer to Section 2.5.1 for instructions on how to install the ILI-MB-E3 to the Cabinet B backbox.

Cabinet Assembly Options	Part Number	Cabinet Dimensions	Installation Instructions (For installation instructions, refer to the Section listed below).
E3 Series System Installation Options			
Cabinet B Backbox	E3BB-BB/RB	19 3/8"W x 19 3/8"H x 4 1/2"D (49W x 49H x 11.4D cm)	Section 2.5.1
Cabinet C, E3 INX-C Plate	E3-INX-CPLATE	19 3/8"W x 30"H x 4 1/2"D (49W x 76H x 11.4D cm)	Section 2.5.2
Cabinet C, E3 INCC-C Plate	E3-INCC-CPLATE	19 3/8"W x 30"H x 4 1/2"D (49W x 76H x 11.4D cm)	Section 2.5.2
Cabinet C, E3-ILI-C Plate (RPT-E3-UPT Connected to ILI-MB-E3/ILI95-MB-E3)	E3-ILI-CPLATE	19 3/8"W x 30"H x 4 1/2"D (49W x 76H x 11.4D cm)	Section 2.5.2
Cabinet D, E3-INX-D Plate	E3-INX-D PLATE	19 3/8"W x 41"H x 4 1/2"D (49W x 104H x 11.4D cm)	Section 2.5.2
Cabinet D, E3-INCC-D Plate	E3-INCC-D PLATE	19 3/8"W x 41"H x 4 1/2"D (49W x 104H x 11.4D cm)	Section 2.5.2
E3 Series Combined Fire and MNS System Installation Options			
Cabinet C, E3 INCC-CAB-C Plate (ACU)	E3-INCC-CPLATE	19 3/8"W x 30"H x 4 1/2"D (49W x 76H x 11.4D cm)	Section 2.5.2
Cabinet C, E3-INX-CAB-C Plate	E3-INX-CPLATE	19 3/8"W x 30"H x 4 1/2"D (49W x 76H x 11.4D cm)	Section 2.5.2
Cabinet D, E3-INX-CAB-D Plate	E3-INX-D PLATE	19 3/8"W x 41"H x 4 1/2"D (49W x 104H x 11.4D cm)	Section 2.5.2
Cabinet D, E3-INCC-CAB-D Plate (ACU)	E3-INCC-D PLATE	19 3/8"W x 41"H x 4 1/2"D (49W x 104H x 11.4D cm)	Section 2.5.2
Retrofit Installation Options			
IF600 Retrofit B-Slim Cabinet	E3BB-RBSLIM	14"W x 20"H x 4 1/2"D (35.5W x 50.8H x 11.4D cm)	Section 2.5.3.1
600XL Retrofit Cabinet C Backbox E3-INCC-C Plate	600XL-RETROFIT (E3-INCC-CPLATE)	22"W x 30"H x 5 1/2"D (55.8W x 76H x 13.9D)	Section 2.5.3.2
7200 Cabinet B, E3-INCC-C Plate	E3-INCC-CPLATE	21"W x 28 1/2"H x 4"D (53.34W x 72.39H x 10.16D cm)	Section 2.5.3.2
7200 Cabinet B, E3-ILI-C Plate	E3-ILI-CPLATE	21"W x 28 1/2"H x 4"D (53.34W x 72.39H x 10.16D cm)	Section 2.5.3.2
7200 Cabinet C, E3-INCC-D Plate	E3-INCC-D PLATE	21"W x 38"H x 4"D (53.34W x 96.52H x 10.16D cm)	Section 2.5.3.2
NOTE: Each PM-9/PM-9G power supply requires only one ILI-MB-E3.			

Table 2.4.1 IILI-MB-E3 Assembly Installation Options

2.5 ILI-MB-E3 Installation Instructions

1. Remove the ILI-MB-E3 sub-assembly from its static-shield bag, observing proper static protection measures.
2. Visually inspect the unit for damage.
If any components are damaged, notify the shipping carrier immediately. Report missing components to Gamewell-FCI Customer Service.
3. Use the Hardware Kit provided with the unit.
4. The ILI-MB-E3 sub-assembly can be installed in several types of configurations in the E3 Series cabinets and Retrofit cabinets.

To determine the ILI-MB-E3 installation that you require, refer to the following documents:

- *E3 Series Cabinets B, C, D, Retrofit, DR-C4/DR-D4 and EQ Cabinets Installation Instructions, P/N: LS10082-000GF-E*
- *E3 Series, Remote Annunciator Display and Retrofit Cabinets Installation Instructions, P/N: LS10083-000GF-E*

2.5.1 ILI-MB-E3 Installed to the Cabinet B Backbox

1. Align and mount the ILI-MB-E3 to the studs in the backbox.
2. Insert eight standoffs (3/16" hex, #4-40 x 1.25") in the eight-hole mounting pattern and secure the standoffs to the backbox as shown in Location 1 of the figure below. (Note: PCB orientation).



NOTE: You can use standoffs to mount the DACT-E3/RPT-E3-UTP or the ANX on top of the ILI-MB-E3.

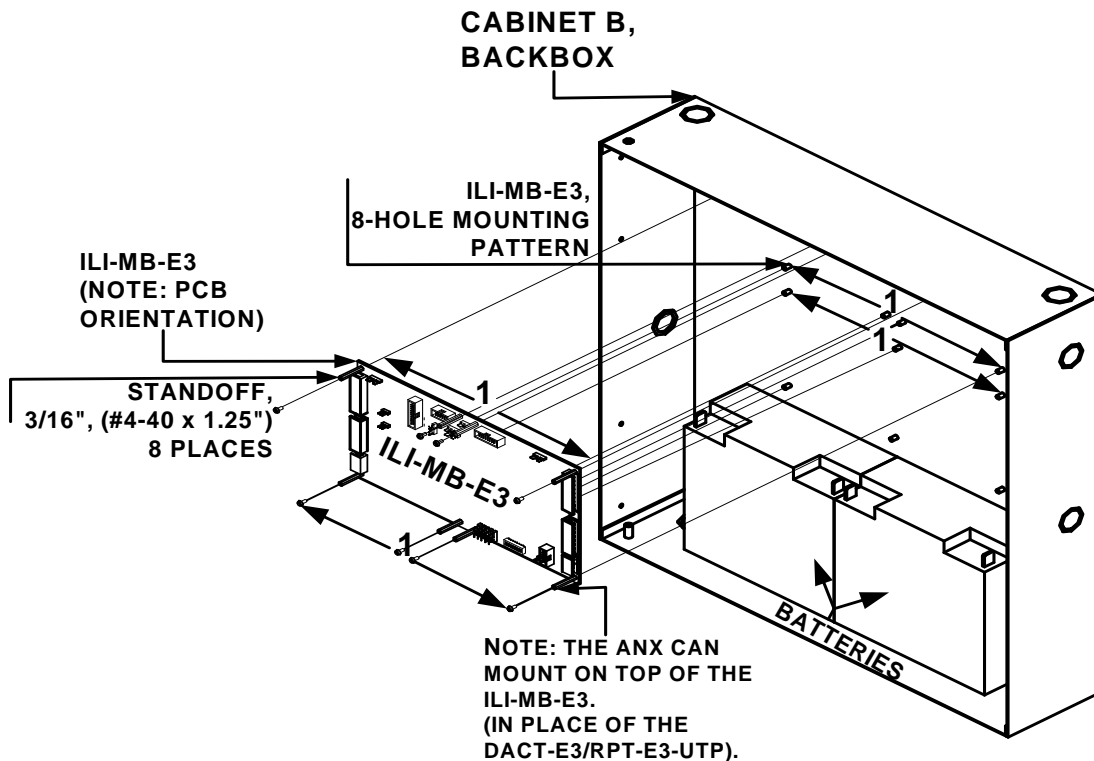

Figure 2.5.1.1 ILI-MB-E3 Installed to the Cabinet B Backbox

2.5.2 ILI-MB-E3 Installed to an E3 Series Mounting Plate Configuration

The ILI-MB-E3 can be installed in the following E3 Series cabinets and mounting plates.

E3 Series Cabinet C

- E3-INCC-C Plate
- E3-ILI-C Plate
- E3-INX-C Plate

E3 Series Cabinet D

- E3-INCC-D Plate
- E3-INX-D Plate

1. Align and place the ILI-MB-E3 on top of the E3 Series mounting plate.
2. Insert eight standoffs (3/16" HEX x #4-40, x 1.25") into the eight-hole mounting pattern and secure the standoffs to the E3 Series mounting plate as shown in Location 1 of the figure below. (Note: PCA orientation).

Figure 2.5.2.1 illustrates the ILI-MB-E3 installed to the Cabinet C, E3-INCC-C Plate.

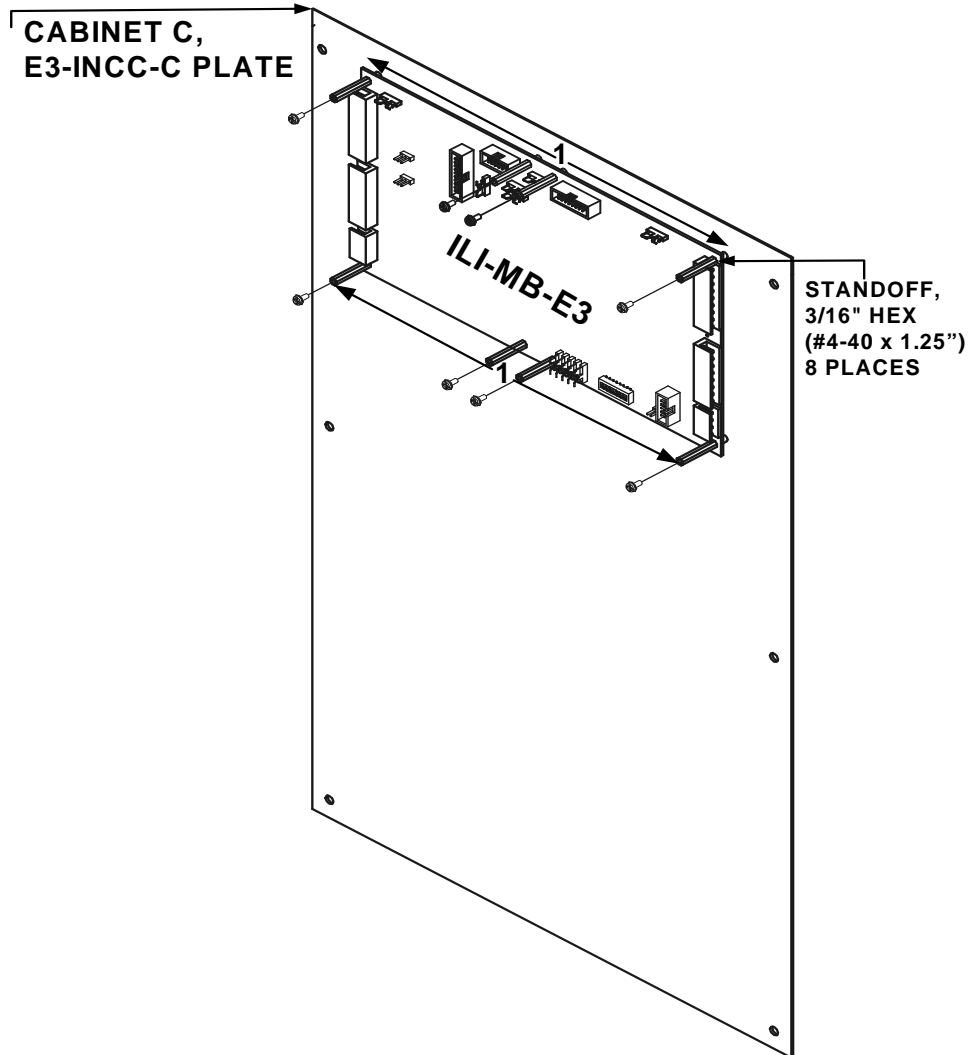

Figure 2.5.2.1 ILI-MB-E3 Installed to an E3 Series Mounting Plate

2.5.3 ILI-MB-E3 Installed to the Retrofit Cabinet, Mounting Plates

The ILI-MB-E3 can be installed in the following retrofit cabinet mounting plates.

B-Slim Cabinet

- B-SLIM-E3 Plate

600XL Retrofit Cabinet

- E3-INCC-C Plate

7200 Cabinet B

- E3-INCC-C Plate
- E3-ILI-C Plate

7200 Cabinet C

- E3-INCC-D Plate

2.5.3.1 ILI-MB-E3 Installed to the B-SLIM-E3 Plate

1. Align and mount the ILI-MB-E3 to the pins on the B-Slim-E3 Plate.
2. Insert the eight screws (#4-40) into the eight-hole mounting pattern and secure the screws to the B-SLIM-E3 plate as shown in Location 1 of the figure below.

2.5.3.2 ILI-MB-E3 Installed to the 600XL or 7200 Retrofit Cabinet Mounting Plates

1. Align and mount the ILI-MB-E3 to the pins on the retrofit cabinet, mounting plate.
2. Insert the eight standoffs (3/16" HEX #4-40, x 1.25") into the eight-hole mounting pattern and secure the standoffs to the retrofit cabinet, mounting plate as shown in Location 1 of the figure below.

NOTE: Use standoffs to mount the DACT-E3/RPT-E3-UTP or the ANX on top of the ILI-MB-E3.

Figure 2.5.3.1.1 illustrates the ILI-MB-E3 installed to the B-SLIM-E3 Plate

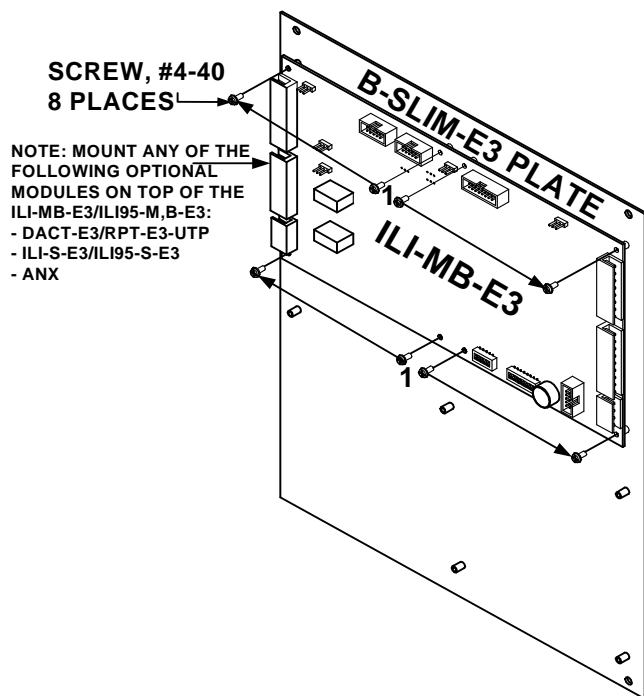

Figure 2.5.3.1.1 ILI-MB-E3 Installed to the B-SLIM-E3 Plate

Figure 2.5.3.2.1 illustrates the ILI-MB-E3 installed to the 7200 Cabinet mounting plates.

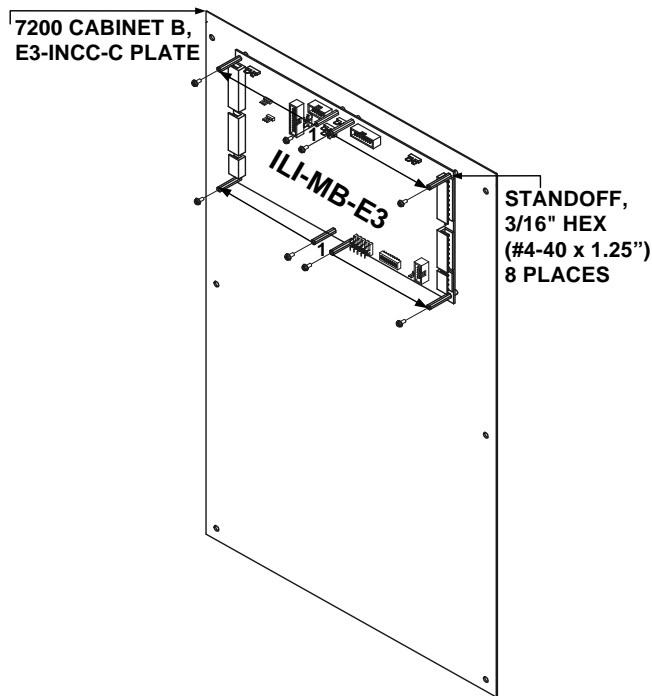

Figure 2.5.3.2.1 ILI-MB-E3 Installed to the 7200 Retrofit Cabinet Mounting Plate

Section 3: Wiring

3.1 Signaling Line Circuits

The ILI-MB-E3 provides two, 24 VDC Class A, Style 6, 7 or Class B, Style 4 signaling line circuits. See Figure 3.1.1 for wiring information. Style 7 wiring requires the use of an M500X Isolator Module (ILI-MB-E3) on both sides of a device.

ILI-MB-E3 Wiring Designations:

SLC 1 Style 4	TB4-8 (+), TB4-7 (-)
SLC 2 Style 4	TB4-4 (+), TB4-3 (-)
SLC 1 Style 6	TB4-8 OUT, TB4-6 RETURN TB4-7 OUT, TB4-5 RETURN
SLC-2 Style 6	TB4-4 OUT, TB4-4-2 RETURN TB4-2 OUT, TB4-1 RETURN

(Polarity markings indicate the polarity that should be maintained throughout the circuit. Polarity connected to the circuit must be observed on all devices).

Circuit Ratings:

24 VDC (nominal)	
Current:	0.051 amp Max (supervisory)
	0.136 amp max. (alarm)
	0.100 amp max. Steady State (short circuit)
	40 Ohms max. line impedance
	0.5 µf max. line capacitance

Ground fault test

impedance: Zero Ohms

Wiring: 18 AWG minimum, twisted-pair, unshielded

Class 2 Power-Limited, Supervised

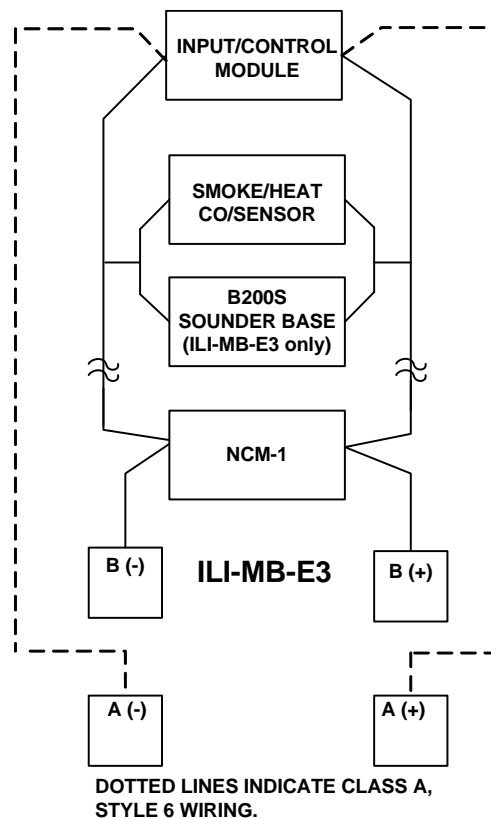

Figure 3.1.1 Signaling Line Circuits

E3 Series Releasing Feature

To actuate the E3 Series Releasing feature, use the signaling line circuit, Honeywell model, TC810S1000, Releasing Control Module. For additional information on the Honeywell TC810S1000 device, refer to the Honeywell, TC810S1000 Releasing Control Module Installation and Maintenance Instructions, P/N:156-3367-000.

NOTE 1: SURVIVABILITY CLAUSE:

Per the National Fire Alarm Code, NFPA 72, all circuits necessary for the operation of the notification appliances shall be protected until they enter the evacuation signaling zone that they serve. Any of the following methods shall be considered acceptable as meeting these requirements.

- 1) A 2-hour rated cable or cable system
- 2) A 2-hour rated enclosure
- 3) Performance alternatives approved by Authority Having Jurisdiction (AHJ)

3.2 Notification Appliance Circuits

The Notification Appliance Circuits (NACs) are connected from the ILI-MB-E3. The ILI-MB-E3 provides two, 24 VDC Class A, Style Z or Class B, Style Y notification appliance circuits. The E3 NAC circuits synchronize the horn and strobe outputs in the ILI-MB-E3 panels. To enable the NAC Sync Option Feature, select the Sync Option in CAMWorks. For additional information on the NAC Sync Option, refer to the CAMWorks Online Help. See Figure 3.2.1 for wiring information. See the *Compatibility Addendum, P/N: 9000-0427-L8*, for a list of approved compatible devices.

ILI-MB-E3 Wiring Designations:

NAC 1 – Style Y	TB2-1 (+), TB2-2 (-)
NAC 2 – Style Y	TB2-5 (+), TB2-6 (-)
NAC 1 – Style Z	TB2-1 OUT, TB2-3 RETURN
NAC 1 - Style Z	TB2-2 OUT, TB2-4 RETURN
NAC 2 – Style Z	TB2-5 OUT, TB2-7 RETURN
	TB2-6 OUT, TB2-8 RETURN

(Polarity markings indicate the polarity of the circuit in alarm condition). Use UL Listed End-of-Line Resistor EOL-N (33K), P/N 4700-0484 for Class B, Style Y wiring.

Circuit Ratings:

24 VDC (Nominal)	
Max. alarm load:	2.0 A/circuit Special Application 0.2 A Regulated
Ground fault test impedance:	Zero ohms
Wiring:	18 AWG minimum
Class 2 Power-Limited,	Supervised

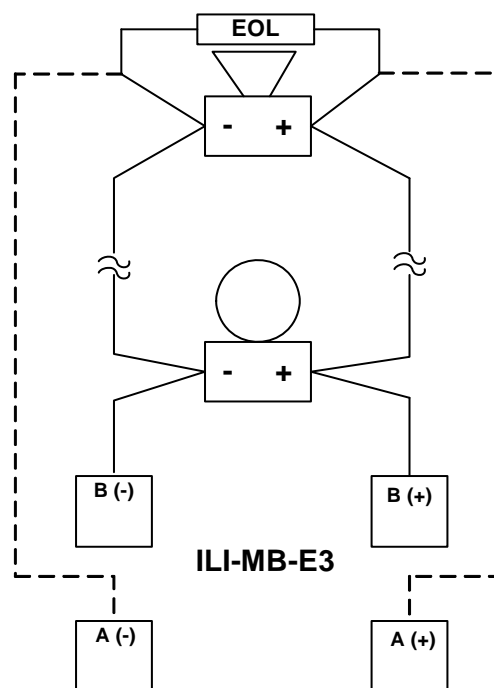

DOTTED LINES INDICATE CLASS A, STYLE Z WIRING. REMOVE EOL FOR CLASS A, STYLE Z OPERATION

Figure 3.2.1 Notification Appliance Circuits

3.2.1. End-of-Line Resistor Settings

Table 3.2.1.1 lists the End-of-Line Resistor settings.

ILI-MB-E3 (Second Generation) End-of-Line Resistor	ILI95-MB-E3 End-of-Line Resistor
For the ILI-MB-E3, use UL Listed End of Line Resistor model ELR-47K for Class B, Style Y wiring. The model ELR-47K is supplied with the ILI-MB-E3. A range of other UL Listed End of Line Resistors may be connected to these NAC circuits if they are within the specified range listed in Table 3.2.2.1.	For the ILI95-MB-E3, use UL Listed End-of-Line Resistor EOL-N (33K), P/N 4700-0484 for Class B, Style Y wiring.

Table 3.2.1.1 ILI-MB-E3 Versions, End-of-Line Resistors

Table 3.2.2.1 lists the End of Line Resistor ranges that are available for use.

End of Line Resistor Ranges
6.2 K - 47 K, 1/4 W or higher
3.2 K - 6.2 K, 1/2 W or higher
1.5 K - 3.2 K, 1 W or higher

Table 3.2.2.1 End of Line Resistor Ranges



NOTE: SURVIVABILITY CLAUSE:

Per the National Fire Alarm Code, NFPA 72, all circuits necessary for the operation of the notification appliances shall be protected until they enter the evacuation signaling zone that they serve. Any of the following methods shall be considered acceptable as meeting these requirements.

- 1) A 2-hour rated cable or cable system
- 2) A 2-hour rated enclosure
- 3) Performance alternatives approved by Authority Having Jurisdiction (AHJ)

3.3 ILI-MB-E3 Outputs

The ILI-MB-E3 provides output for a Local Energy City Master Box, reversing polarity output for leased line connection, or Releasing Service. Table 3.3.1 lists the ILI-MB-E3 outputs.

Ratings	Master Box (NPL)	Polarity Reversal (PL)	Releasing Service
Nominal Voltage	24 VDC	24 VDC	24 VDC
Supervisory Current:	.0018 amp	.012 amp	.0005 amp
Alarm Current:	.510 amp (max.)	.012 amp	.700 amp 2 Ohms (max.)
Line Resistance	35 Ohms (max.)		
Trip Coil Resistance	14.5 Ohms (max.)		

Table 3.3.1 ILI-MB-E3 Outputs

3.4 ILI-MB-E3 Wiring Requirements

Table 3.4.1 lists the wiring requirements for the ILI-MB-E3 sub-assembly.

Circuit Type	Circuit Function	Wire Requirements	Distance	Typical Wire Type*
SLC (Class 2 Power-Limited)	Connects to intelligent and addressable modules.	Twisted-unshielded pair, 12 to 18 AWG (3.1 to 0.78 mm ²) 40 Ohms maximum per length of Style 6 & 7 loops. 40 Ohms combined-branch circuits maximum for Style 4 loop. MC cable with 2 conductor twisted.	10,000 ft. (3,000 m)	12 AWG (3.1 mm ²)
			8,000 ft. (2,400 m)	14 AWG (2.00 mm ²)
			4,875 ft. (1,450 m)	16 AWG (1.30 mm ²)
			3,225 ft. (980 m)	18 AWG (0.78 mm ²)
		Note: The maximum total capacitance of all SLC wiring (both between conductors and from any conductor to ground) should not exceed 0.5 microfarads.		
RS-485 (Class 2 Power-Limited)	Connects to LCD-E3, LCD-SLP, ASM-16, ANU-48 and LCD-7100/RAN-7100 modules.	Twisted-unshielded pair with a characteristic impedance of 120 Ohms. 18 AWG (0.78 mm ²) minimum.	3,000 ft. (.914 m) (maximum)	16 AWG (1.30 mm ²)
RS-232 (Class 2 Power-Limited)	Connects to Printers, CRT, or PC.	Twisted-unshielded pair. 18 AWG (0.78 mm ²) minimum	50/15.24 (without modem)	16 AWG (1.30 mm ²)
NAC Notification Appliance Circuit (Class 2 Power-Limited)	E3 connects to Notification Appliances	12-18 AWG (3.1 to 0.78 mm ²) At alarm current level, no more than a 1.2 V drop at the end of the circuit, or sized to provide the minimum rated operating voltage of the appliances used.	To meet 1.2 V drop, or sized to provide the minimum rated operating voltage of the appliances used.	12 to 18 AWG (3.1 to 0.78 mm ²)
24 VDC Power Runs (Class 2 Power-Limited)	To Transmitter Annunciator	12-18 AWG (3.1 to 0.78 mm ²). Size wire so that no more than 1.2 V drop across wire run from supply source to end of any branch.	To meet 1.2 volt drop	12 to 18 AWG (3.1 to 0.78 mm ²)
ARCNET (Class 2 Power-Limited)	Provides interface between network nodes. ARCNET should be installed in a separate conduit.	Twisted-unshielded pair low capacitance 18 AWG, or ribbon cable to the other modules within the same cabinet.	3,000 ft. (.914 m)	18 AWG (3.1 mm ²)

NOTE: Lightning arresters required on circuits extending between buildings; 999 meter length maximum to meet UL[®] Standard 1459.

Table 3.4.1 ILI-MB-E3 Wiring Requirements

3.5 ILI-MB-E3 Wiring Connections

Figure 3.5.1 illustrates the ILI-MB-E3, (First Generation) and Figure 3.5.2 illustrates the ILI-MB-E3, (Second Generation).

ILI-MB-E3 (First Generation)

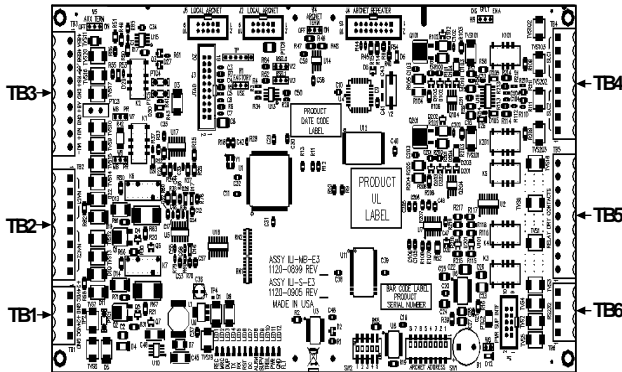

Figure 3.5.1 ILI-MB-E3 (First Generation) Module

ILI-MB-E3 (Second Generation)

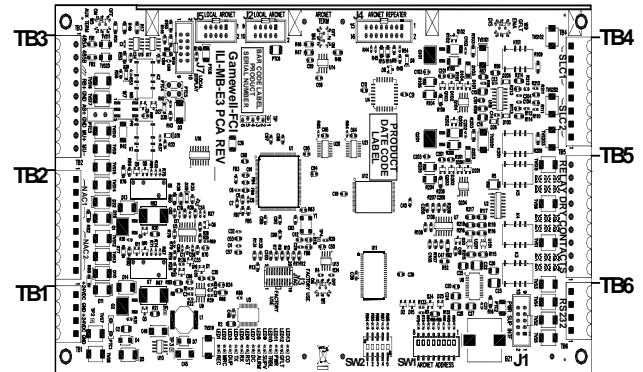

Figure 3.5.2 ILI-MB-E3 (Second Generation) Module

3.5.1 ILI-MB-E3 Wiring Designations

Table 3.5.1.1 illustrates the ILI-MB-E3 terminal designations for the First and Second Generation versions.

Designation	Description	Comments
ILI-MB-E3 (First and Second Generation) Wiring Designations		
TB1-1, TB1-3	+24 V IN	+24 VDC Input from PM-9/PM-9G TB4-1
TB1-2, TB1-4	GND	Common negative from PM-9/PM-9G TB4-2
TB2-1	NAC 1 B+	Notification Appliance Circuit 1 (See Note 6)
TB2-2	NAC 1 B -	Notification Appliance Circuit 1 (See Note 6)
TB2-3	NAC 1 A+	Notification Appliance Circuit 1 (See Note 6)
TB2-4	NAC 1 A-	Notification Appliance Circuit 1 (See Note 6)
TB2-5	NAC 2 B+	Notification Appliance Circuit 2 (See Note 6)
TB2-6	NAC 2 B-	Notification Appliance Circuit 2 (See Note 6)
TB2-7	NAC 2 A+	Notification Appliance Circuit 2 (See Note 6)
TB2-8	NAC 2 A-	Notification Appliance Circuit 2 (See Note 6)
TB3-1	AUX RS-485 A	Output to LCD-E3, LCD-SLP, ASM-16, ANU-48, LCD-7100/RAN-7100, DACT-E3 (See Note 3)
TB3-2	AUX RS-485 B	Output to LCD-E3, LCD-SLP, ASM-16, ANU-48, LCD-7100/RAN-7100, DACT-E3 (See Note 3)
TB3-3	Earth Ground	Connect to water pipe ground
TB3-4	Resettable B+	Auxiliary resettable 24 VDC power
TB3-5	GND	Common negative
TB3-6	Non-resettable B+	Auxiliary non-resettable 24 VDC power Wire TC810S1000 releasing control module @ 24VDC to non-resettable B+ (System Common).
TB3-7	GND	Common negative
TB3-8	Municipal Ckt+	Output to Local Energy City Box, Remote Station or Releasing Solenoid - Non Power-limited (See Note 7)
TB3-9	Municipal Ckt -	Output to Local Energy City Box or Remote Station or Releasing Solenoid - Non Power-limited (See Note 7)
TB4-1	SLC 2 A-	SLC 2 Style 6 / 7 Return (See Note 5)
TB4-2	SLC 2 A+	SLC 2 Style 6 / 7 Return (See Note 5)
TB4-3	SLC 2 B-	SLC 2 Style 4 / 6 / 7 Out (See Note 5)
TB4-4	SLC 2 B+	SLC 2 Style 4 / 6 / 7 Out (See Note 5)
TB4-5	SLC 1 A-	SLC 1 Style 6 / 7 Return (See Note 5)
TB4-6	SLC 1 A+	SLC 1 Style 6 / 7 Return (See Note 5)

Table 3.5.1.1 ILI-MB- E3 Wiring Designations

Designation	Description	Comments
ILI-MB-E3 (First and Second Generation) Wiring Designations		
TB4-7	SLC 1 B-	SLC 1 Style 4 / 6 / 7 Out (See Note 5)
TB4-8	SLC 1 B+	SLC 1 Style 4 / 6 / 7 Out (See Note 5)
TB5-1	Alarm DC NC	Alarm relay contact, N/C
TB5-2	Alarm DC NO	Alarm relay contact, N/O
TB5-3	Alarm DC Common	Alarm relay contact, Common
TB5-4	Supv DC NC	Supervisory relay contact, N/C
TB5-5	Supv DC NO	Supervisory relay contact, N/O
TB5-6	Supv DC Common	Supervisory relay contact, Common
TB5-7	Trbl DC NC	Trouble relay contact, N/C
TB5-8	Trbl DC NO	Trouble relay contact, N/O
TB5-9	Trbl DC Common	Trouble relay contact, Common
TB6-1	RS-232 GND	For Programming, GND connects to red lead on the download cable P/N 75267. For Printer Port, GND connects to printer DB-9, PIN-5.
TB6-2	RS-232 TxD	For Programming, TxD connects to black lead on the download cable P/N 75267. For Printer Port, TxD connects to printer DB-9, PIN-2.
TB6-3	RS-232 Supervision	Optional Printer Supervision. For Printer Port, SUPV connects to printer DB-9, PIN-4.
TB6-4	RS-232 RxD	For Programming, RxD connects to green lead on the download cable P/N 75267. For Printer Port, RxD connects to printer DB-9, PIN-3.
W1	Factory Jumper	Factory Use Only (Default OUT)
For W2 thru W5 and J7, refer to the subsections: ILI-MB-E3 (First Generation) and ILI-MB-E3 (Second Generation) sections.		
W7, W8	Municipal Jumpers	"MB" = For Master Box / Releasing "PR" = For Polarity Reversal (See Note 7)
W9	Ground Fault Detection	IN = ENABLE OUT = DISABLE (See Note 1)
SW2-1	Switch	1 ON = SLC 1 DISABLED (OFF = SLC 1 ENABLED)
SW2-2	Switch	2 ON = SLC 2 DISABLED (OFF = SLC 2 ENABLED)
SW2-3	Switch	3 ON = NAC 1 & 2 DISABLED (OFF = NAC 1 & 2 ENABLED)
SW2-4	Switch	4 ON = BUZZER DISABLED (OFF = BUZZER ENABLED)
SW2-5	Switch	5 ON = RS-232 115.2 K BAUD (OFF = defined by CAMWorks™)
J1	ILI to PM-9/PM-9G COMM Port	Connects to PM-9/PM-9G J1. (See Notes 1 & 2)
J2	Local ARCNET	Connects to J5 of the next ILI-E3, ILI95-E3 Series or ANX sub-assembly.(See Note 8)
J4	ARCNET Repeater Connector	Connects to INI-VG Series (First/Second/Third Generation) J7 or J10 of the RPT-E3-UTP (See Note 4).
J5	Local ARCNET	Connects to J2 from the previous ILI-E3, ILI95-E3 Series or ANX sub-assembly. (See Note 8).
ILI-MB-E3 (First Generation) Designations		
W2	Factory Jumper	Factory Use Only (Default OUT)
W3	Factory Jumper	Factory Use Only (Default OUT)
W4	ARCNET Termination	OPEN = Normal Operation SHORT = If the ILI-MB-E3 is located at the end of the ARCNET bus.
W5	RS-485 AUX Terminal	OPEN = OFF SHORT = ON (RS-485 Termination)
Used for the ILI-MB-E3, (First Generation) only.		

Table 3.5.1.1 ILI-MB- E3 Wiring Designations (Continued)

Designation	Description	Comments	
ILI-MB-E3 (Second Generation) Wiring Designations			
W4	ARCNET Termination	OFF = If the ILI-MB-E3 is located in the middle of the bus or if it is not used. ON = If the ILI-MB-E3 is located at either end of the ARCNET bus.	Used for ILI-MB-E3, (Second Generation) only.
W5	RS-485 AUX Interface Termination	OFF = Normal Operations ON = ON (RS-485 Termination) (Use if the last device on RS-485 bus also has its termination jumper shorted. Bus termination is recommended, as it improves noise rejection).	
J7	RS-485 Transceiver Port Head	Use the 10-pin ribbon cable to connect from J7 of the ILI-MB-E3 to J5 of the LCD-SLP display.	
Notes			
NOTE 1: Must be IN when connected via ribbon cable from this ILI-MB-E3 at J1 to a PM-9/PM-9G connector J1. Requires the removal of the JMP-1 on the PM-9/PM-9G. Must be OUT when a ribbon cable is not installed in J1 and the ground fault detection is being provided by an INI-VG Series (First/Second/Third Generation) node that is being powered from a common PM-9/PM-9G.			
NOTE 2: Connect J1 to PM-9/PM-9G J1 only when the PM-9/PM-9G is NOT powering an INI-VG Series (First/Second/Third Generation) sub-assembly.			
NOTE 3: Use ILI-MB-E3 Auxiliary RS485 Port (TB3-1 COM A & TB3-2 COM B) to connect to the LCD-E3 (E3 annunciator module), LCD-SLP (E3/S3 annunciator module), LCD-7100/RAN-7100 (7100 Remote Annunciator Module), ASM-16 (Addressable Switch Module), ANU-48 (LED Annunciator Driver Module) or DACT-E3 (E3 Digital Communicator Transmitter).			
NOTE 4: RPT-E3-UTP (E3 Repeater Module) is required when this ILI-MB-E3 is networked via ARCNET to any of the following: - INI-VGE, INI-VGC, INI-VGX, (First/Second/Third Generations) - Another RPT-E3-UTP equipped node In addition, when the ILI-MB-E3 is connected to an NGA (whether the NGA is local or remote), the RPT-E3-UTP is required. It is not required for LOCAL ARCNET communication within a single enclosure. (J2 or J5).			
NOTE 5: For Style 4 use terminals B+ and B- only. For Style 6 use terminals B+ and B- and connect return wires to A+ and A-. For Style 7, wire as for Style 6 and use Isolator Modules and or Isolator Detectors per recommendations as required.			
NOTE 6: NAC1 and NAC2 are rated as 2.0 A Special Application and 0.2 A Regulated.			
NOTE 7: When used for Releasing, must be configured in CAMWorks™ for Releasing in the General Settings Section.			
NOTE 8: Use the ANX for Fire applications only.			
NOTE 9: The PRN-7 Printer is a dot-matrix printer. It is shipped with a DB-9 Adapter Kit that provides the necessary hardware and cables for installation. For additional information on the PRN-7 Printer, refer to the Manufacturer's Installation Guide.			

Table 3.5.1.1 ILI-MB- E3 Wiring Designations (Continued)

3.5.2 ILI-MB-E3 Programming Address Switch Settings

Set the address using the switch, SW1. Figure 3.5.2.1 illustrates the programming address switch settings for the ILI-MB-E3.

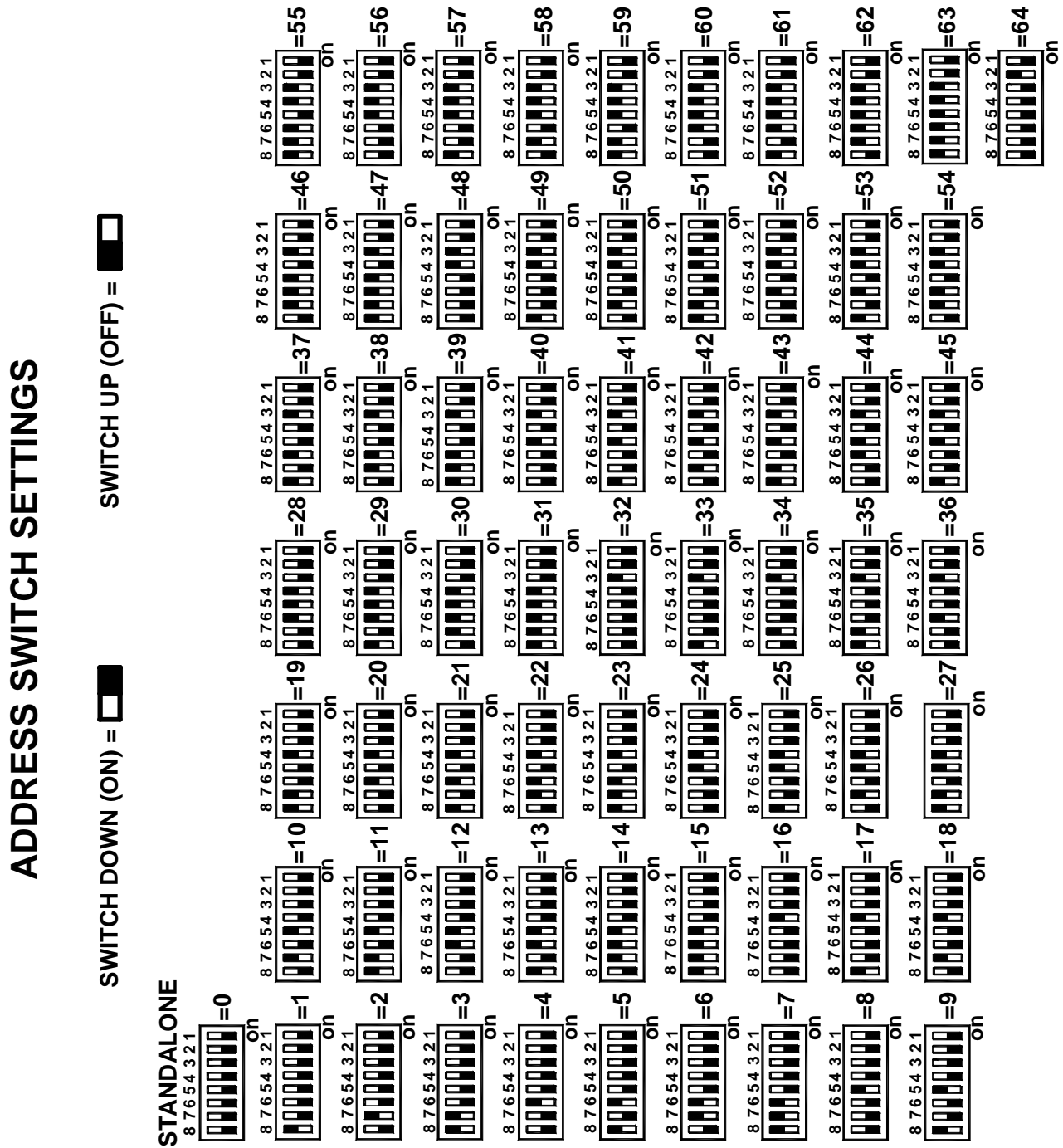

Figure 3.5.2.1 ILI-MB-E3 Programming Address Switch Settings

3.5.3 ILI-MB-E3 Wiring Diagrams

3.5.3.1 ILI-MB-E3 (First Generation) Diagram

Figure 3.5.3.1.1 illustrates the wiring connections for the ILI-MB-E3 (First Generation) sub-assembly.

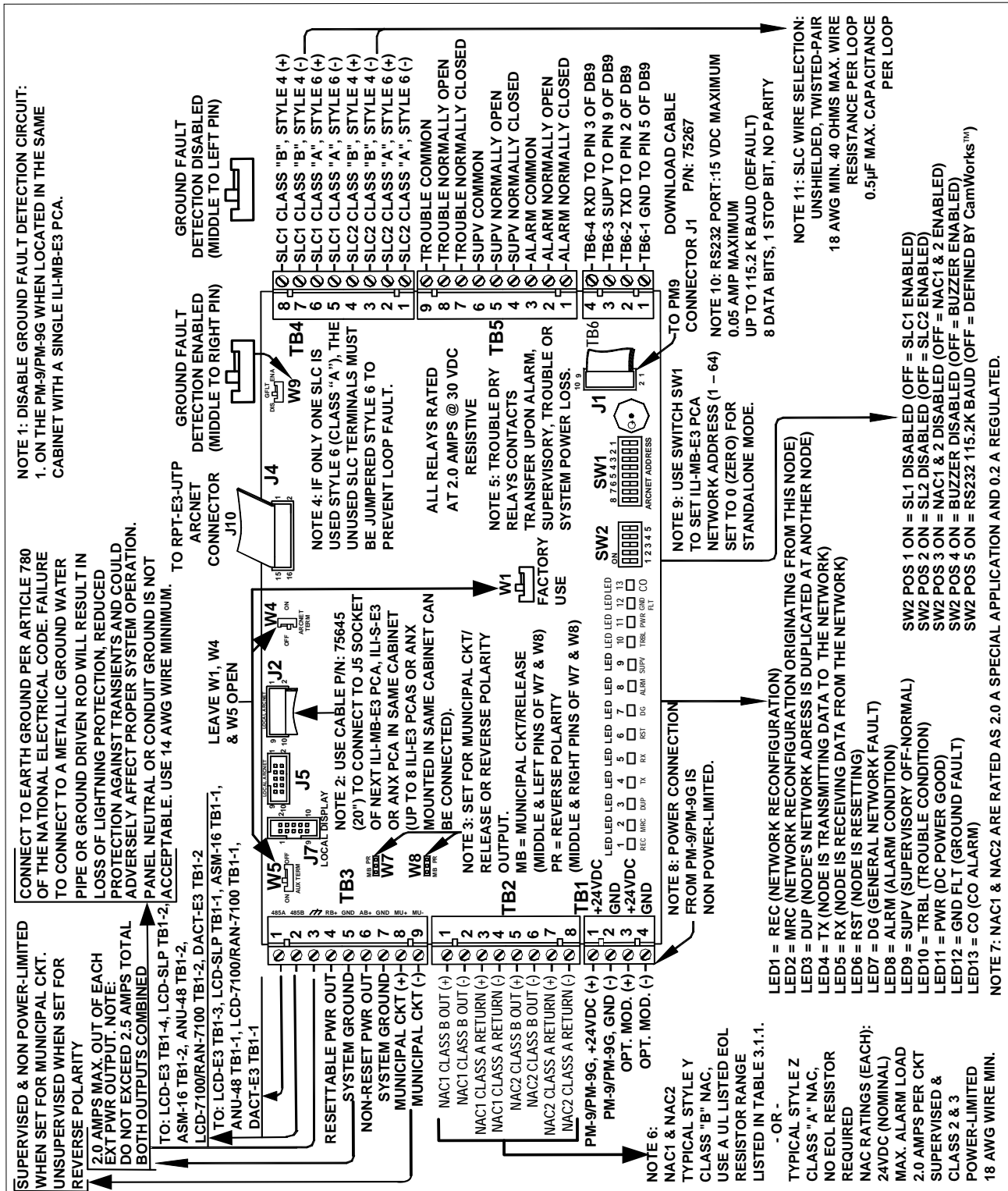

Figure 3.5.3.1.1 ILI-MB-E3 (First Generation) Wiring Diagram

3.5.3.2 ILI-MB-E3 (Second Generation) Diagram

Figure 3.5.3.2.1 illustrates the wiring connections for the ILI-MB-E3 (Second Generation) sub-assembly.

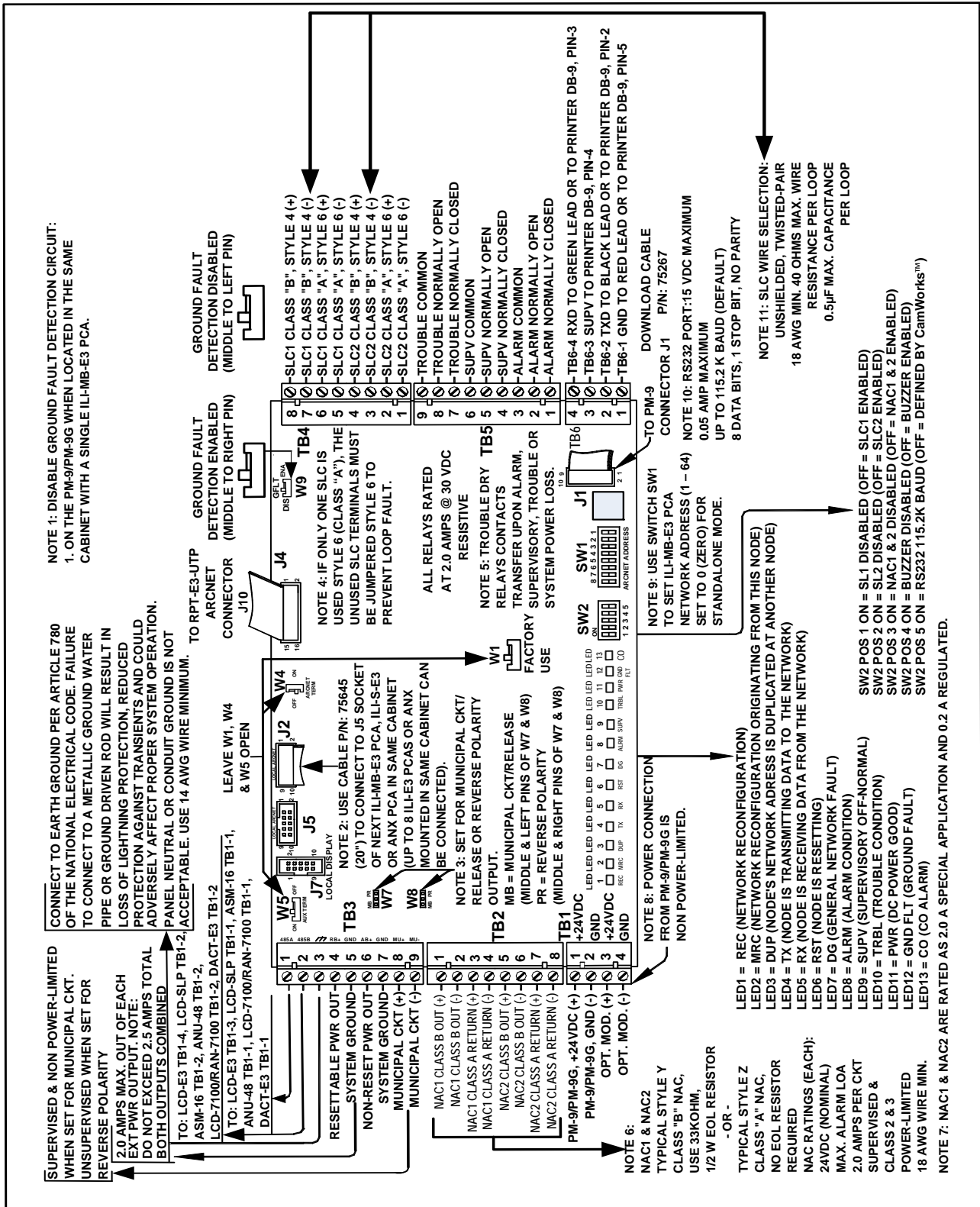

Figure 3.5.3.2.1 ILI-MB-E3 (Second Generation) Wiring Diagram

Section 4: E3 Series Configurations

Minimum E3 Series Configuration

The minimum E3 Series configuration to use in a working system requires the following:

- A) ILI-MB-E3, Intelligent Loop Interface, Main Board



NOTE: In a standard E3 Series configuration, install only one ILI-MB-E3 for one PM-9/PM-9G power supply connected to an FACP cabinet.

- B) PM-9/PM-9G Power Supply
- C) LCD-E3, LCD-SLP or NGA Display Module (only one module is required per a Networked System)

Optional E3 Series Configuration

The following optional modules can be used with the ILI-MB-E3 in an E3 Series configuration.

- A) RPT-E3-UTP, Repeater Module (Required for Distributed Network Systems)
(The RPT-E3-UTP is required when you use the NGA).
- B) DACT-E3, Digital Alarm Communicator Transmitter
- C) INI-VG Series, (Intelligent Network Interface - Voice Gateway Modules (First/Second/Third Generation))
- D) ANX, Addressable Node Expander
(Use the ANX for Fire applications only).
- E) ILI-S-E3, Intelligent Loop Interface-Expander Board
(Use up to eight ILI-S-E3 modules in an E3 Series configuration).
- F) ILI95-S-E3, Intelligent Loop Interface95-Expander Board

Display Panels:

- G) ANU-48, Remote LED Driver Assembly
- H) ASM-16, Addressable Switch Module
- I) LCD-E3, LCD Display Module
- J) LCD-SLP, Liquid Crystal Display-Small Loop Panel
- K) LCD-7100/RAN-7100
- L) NGA, Network Graphic Annunciator

Section 5: Programming Requirements

This product uses the CAMWorks™ Software Program. Installers must be Gamewell-FCI Factory Certified to program this product. For additional information on this product, contact the Gamewell-FCI Customer Support to schedule the Factory Certified Training.



NOTE: For information on the latest version of CAMWorks, see the Gamewell-FCI website, www.gamewell-fci-esd.com.

Section 6: Reference Documentation

Table 6.1 lists the UL-Controlled documentation assigned to the S3 Series and E3 Series Systems. If you require detailed installation instructions on cabinetry, wiring and specifications, you can download the following UL-Controlled documents from the ESD site on the Gamewell-FCI Website (gamewell-fci-esd.com).

Part Number	Title
UL Listing Document	
LS10005-051GF-E	S3 Series (Small Addressable Fire Alarm Control Panel) UL Listing Document
LS10080-051GF-E	E3 Series Fire System (Expandable Emergency Evacuation System) UL Listing Document
Manuals	
9000-0575	E3 Series Broadband Installation/Operation Manual
9000-0577	E3 Series Classic Installation/Operation Manual
LS10013-000GF-E	E3 Series Combined Fire and MNS Installation/Operation Manual
Installation Instructions	
9000-0491	LCD-7100 (Remote Serial Annunciator) Installation Instructions
9000-0544	AM-50 Series (50 Watt Amplifiers) Installation Instructions
9000-0545	INX, INX CAB-B, INX CAB-C and INX CAB-D Installation Instructions
9000-0546	INCC Intelligent Network Interface Installation Instructions
9000-0548	PM-9 (Power Supply) Installation Instructions
9000-0549	INI-VG Series (Intelligent Network Interface) Installation Instructions
9000-0550	ASM-16 (Addressable Switch Module) Installation Instructions
9000-0564	ANU-48 (Remote LED Driver Annunciator) Installation Instructions
9000-0568	NGA (Network Graphic Annunciator) Installation Instructions
9000-0569	ILI-S-E3 (Intelligent Loop Interface - Expansion Board) Installation Instructions
9000-0579	ILI-MB-E3 (Intelligent Loop Interface - Main Board) Installation Instructions
9000-0580	RPT-E3-UTP (Repeater-E3 Unshielded Twisted-Pair) Installation Instructions
9000-0581	DACT-E3 (Digital Alarm Communicator Transmitter) Installation Instructions
9000-0582	LCD-E3 (Liquid Crystal Display-E3) Installation Instructions
9001-0017	ILI95-MB-E3 (Intelligent Loop Interface-95 - Main Board) Installation Instructions
9001-0018	ILI95-S-E3 (Intelligent Loop Interface-95 - Expansion Board) Installation Instructions
9001-0055	PM-9G (Power Supply) Installation Instructions
9001-0058	E3 Series Cabinet Trim Rings Installation Instructions
9001-0064	ANX (Addressable Node Expander) Installation Instructions
9001-0065	E3BB-FLUSH-LCD-CAB A2 Remote Flush Annunciator Installation Instructions
9001-0066	RAN-7100 (Remote Alphanumeric Annunciator) Installation Instructions
LS10044-000GF-E	SLC-PM/SLC95-PM (Signaling Line Circuit-Personality Modules Installation Instructions
LS10045-000GF-E	LCD-SLP (Liquid Crystal Display-Smart Loop Panel) Installation Instructions
LS10046-000GF-E	FML-E3/FSL-E3 (Fiber-Optic Multi-Mode/Fiber-Optic Single-Mode) Installation Instructions
LS10058-000GF-E	FLPS-7 (Power Supply) Installation Instructions
LS10082-000GF-E	E3 Series Cabinets B, C, D, Retrofit, DR-C4/DR-D4 and EQ Cabinets Installation Instructions
LS10083-000GF-E	E3 Series, Remote Annunciator Display and Retrofit Cabinets Installation Instructions
LS10218-000GF-E	INI-VG Series (Intelligent Network Transponder-Voice Gateway-Third Generation) Instructions
Addendum	
9000-0427-L8	Compatibility Addendum to Gamewell-FCI Installation/Operation Manuals UL File S1869 Vol. 8C
Supplement and Frame and Posts	
LS10138-151GF-E	E3 Series Releasing Systems Supplement
9000-0583	E3 Series for the LCD-E3 Operating Instructions
LS10056-000GF-E	S3 Series (Small Addressable Fire Alarm Control Panel System), Operating Instructions
LS10121-000GF-E	E3 Series for the LCD-SLP Operating Instructions

Table 6.1 Reference Documentation

Honeywell Gamewell-FCI

12 Clintonville Road
 Northford, CT 06472-1610
 203.484.7161
www.gamewell-fci.com

9000-0579 | M7 | 10/18
 ©2018 Honeywell International Inc.

Honeywell