



**Control Relay Module**  
**ACM-8RF**  
**Instruction Manual**

## Fire Alarm System Limitations

**An automatic fire alarm system**—typically made up of smoke detectors, heat detectors, manual pull stations, audible warning devices, and a fire alarm control with remote notification capability—can provide early warning of a developing fire. Such a system, however, does not assure protection against property damage or loss of life resulting from a fire.

The Manufacturer recommends that smoke and/or heat detectors be located throughout a protected premise following the recommendations of the current edition of the National Fire Protection Association Standard 72 (NFPA 72), manufacturer's recommendations, State and local codes, and the recommendations contained in the Guide for Proper Use of System Smoke Detectors, which is made available at no charge to all installing dealers. A study by the Federal Emergency Management Agency (an agency of the United States government) indicated that smoke detectors may not go off in as many as 35% of all fires. While fire alarm systems are designed to provide early warning against fire, they do not guarantee warning or protection against fire. A fire alarm system may not provide timely or adequate warning, or simply may not function, for a variety of reasons:

**Smoke detectors** may not sense fire where smoke cannot reach the detectors such as in chimneys, in or behind walls, on roofs, or on the other side of closed doors. Smoke detectors also may not sense a fire on another level or floor of a building. A second-floor detector, for example, may not sense a first-floor or basement fire.

**Particles of combustion or "smoke"** from a developing fire may not reach the sensing chambers of smoke detectors because:

- Barriers such as closed or partially closed doors, walls, or chimneys may inhibit particle or smoke flow.
- Smoke particles may become "cold," stratify, and not reach the ceiling or upper walls where detectors are located.
- Smoke particles may be blown away from detectors by air outlets.
- Smoke particles may be drawn into air returns before reaching the detector.

The amount of "smoke" present may be insufficient to alarm smoke detectors. Smoke detectors are designed to alarm at various levels of smoke density. If such density levels are not created by a developing fire at the location of detectors, the detectors will not go into alarm.

Smoke detectors, even when working properly, have sensing limitations. Detectors that have photoelectronic sensing chambers tend to detect smoldering fires better than flaming fires, which have little visible smoke.

Detectors that have ionizing-type sensing chambers tend to detect fast-flaming fires better than smoldering fires. Because fires develop in different ways and are often unpredictable in their growth, neither type of detector is necessarily best and a given type of detector may not provide adequate warning of a fire.

Smoke detectors cannot be expected to provide adequate warning of fires caused by arson, children playing with matches (especially in bedrooms), smoking in bed, and violent explosions (caused by escaping gas, improper storage of flammable materials, etc.).

*While a fire alarm system may lower insurance rates, it is not a substitute for fire insurance!*

Heat detectors do not sense particles of combustion and alarm only when heat on their sensors increases at a predetermined rate or reaches a predetermined level. Rate-of-rise heat detectors may be subject to reduced sensitivity over time. For this reason, the rate-of-rise feature of each detector should be tested at least once per year by a qualified fire protection specialist. *Heat detectors are designed to protect property, not life.*

**IMPORTANT!** *Smoke detectors must be installed in the same room as the control panel and in rooms used by the system for the connection of alarm transmission wiring, communications, signaling, and/or power.* If detectors are not so located, a developing fire may damage the alarm system, crippling its ability to report a fire.

**Audible warning devices** such as bells may not alert people if these devices are located on the other side of closed or partly open doors or are located on another floor of a building. Any warning device may fail to alert people with a disability or those who have recently consumed drugs, alcohol or medication. Please note that:

- Strobes can, under certain circumstances, cause seizures in people with conditions such as epilepsy.
- Studies have shown that certain people, even when they hear a fire alarm signal, do not respond or comprehend the meaning of the signal. It is the property owner's responsibility to conduct fire drills and other training exercise to make people aware of fire alarm signals and instruct them on the proper reaction to alarm signals.
- In rare instances, the sounding of a warning device can cause temporary or permanent hearing loss.

**A fire alarm system** will not operate without any electrical power. If AC power fails, the system will operate from standby batteries only for a specified time and only if the batteries have been properly maintained and replaced regularly.

**Equipment used in the system** may not be technically compatible with the control. It is essential to use only equipment listed for service with your control panel.

**Telephone lines** needed to transmit alarm signals from a premise to a central monitoring station may be out of service or temporarily disabled. For added protection against telephone line failure, backup radio transmission systems are recommended.

**The most common cause** of fire alarm malfunction is inadequate maintenance. To keep the entire fire alarm system in excellent working order, ongoing maintenance is required per the manufacturer's recommendations, and UL and NFPA standards. At a minimum, the requirements of Chapter 7 of NFPA 72 shall be followed. Environments with large amounts of dust, dirt or high air velocity require more frequent maintenance. A maintenance agreement should be arranged through the local manufacturer's representative. Maintenance should be scheduled monthly or as required by National and/or local fire codes and should be performed by authorized professional fire alarm installers only. Adequate written records of all inspections should be kept.

## Installation Precautions

**WARNING** - Several different sources of power can be connected to the fire alarm control panel. Disconnect all sources of power before servicing. Control unit and associated equipment may be damaged by removing and/or inserting cards, modules, or interconnecting cables while the unit is energized. Do not attempt to install, service, or operate this unit until this manual is read and understood.

**CAUTION** - *System Reacceptance Test after Software Changes*. To ensure proper system operation, this product must be tested in accordance with NFPA 72 Chapter 7 after any programming operation or change in site-specific software. Reacceptance testing is required after any change, addition or deletion of system components, or after any modification, repair or adjustment to system hardware or wiring.

All components, circuits, system operations, or software functions known to be affected by a change must be 100% tested. In addition, to ensure that other operations are not inadvertently affected, at least 10% of initiating devices that are not directly affected by the change, up to a maximum of 50 devices, must also be tested and proper system operation verified.

This system meets NFPA requirements for operation at 0-49° C/32-120° F and at a relative humidity of 85% RH (non-condensing) at 30° C/86° F. However, the useful life of the system's standby batteries and the electronic components may be adversely affected by extreme temperature ranges and humidity. Therefore, it is recommended that this system and all peripherals be installed in an environment with a nominal room temperature of 15-27° C/60-80° F.

**Verify that wire sizes are adequate** for all initiating and indicating device loops. Most devices cannot tolerate more than a 10% I.R. drop from the specified device voltage.

*Adherence to the following will aid in problem-free installation with long-term reliability:*

**Like all solid state electronic devices**, this system may operate erratically or can be damaged when subjected to lightning-induced transients. Although no system is completely immune from lightning transients and interferences, proper grounding will reduce susceptibility. *Overhead or outside aerial wiring is not recommended, due to an increased susceptibility to nearby lightning strikes.* Consult with the Technical Services Department if any problems are anticipated or encountered.

**Disconnect AC power and batteries** prior to removing or inserting circuit boards. Failure to do so can damage circuits.

**Remove all electronic assemblies** prior to any drilling, filing, reaming, or punching of the enclosure. When possible, make all cable entries from the sides or rear. Before making modifications, verify that they will not interfere with battery, transformer, and printed circuit board location.

**Do not tighten screw terminals** more than 9 in.-lbs. Over-tightening may damage threads, resulting in reduced terminal contact pressure and difficulty with screw terminal removal.

**Though designed to last many years**, system components can fail at any time. This system contains static-sensitive components. Always ground yourself with a proper wrist strap before handling any circuits so that static charges are removed from the body. Use static-suppressive packaging to protect electronic assemblies removed from the unit.

**Follow the instructions** in the installation, operating, and programming manuals. These instructions must be followed to avoid damage to the control panel and associated equipment. FACP operation and reliability depend upon proper installation by authorized personnel.

## FCC Warning

**WARNING:** This equipment generates, uses, and can radiate radio frequency energy and if not installed and used in accordance with the instruction manual, may cause interference to radio communications. It has been tested and found to comply with the limits for class A computing device pursuant to Subpart B of Part 15 of FCC Rules, which is designed to provide reasonable protection against such interference when operated in a commercial environment. Operation of this equipment in a residential area is likely to cause interference, in which case the user will be required to correct the interference at his own expense.

### Canadian Requirements

This digital apparatus does not exceed the Class A limits for radiation noise emissions from digital apparatus set out in the Radio Interference Regulations of the Canadian Department of Communications.

Le présent appareil numérique n'émet pas de bruits radioélectriques dépassant les limites applicables aux appareils numériques de la classe A prescrites dans le Règlement sur le brouillage radioélectrique édicté par le ministère des Communications du Canada.

This page intentionally left blank

# Table of Contents

## 1. Introduction

<b>General</b> .....	<b>7</b>
<b>Mounting</b> .....	<b>7</b>
<b>Features</b> .....	<b>8</b>
Relays .....	8
24 VDC Power and Earth Ground.....	8
EIA-485 Communications.....	9
Address Switches .....	9
Relay Function Selection.....	9
Mode Selection.....	9
<b>Related Documentation</b> .....	<b>9</b>

## 2. Installation

<b>Mounting the Enclosure</b> .....	<b>11</b>
<b>Wiring the Power Terminal Blocks</b> .....	<b>11</b>
<b>Wiring the Relay Terminal Blocks</b> .....	<b>12</b>
<b>Wiring the EIA-485 Terminal Blocks</b> .....	<b>13</b>
Wiring Specifications .....	13
EIA-485 Shield in Conduit .....	13
EIA-485 Shield Not in Conduit .....	14
EIA-485 - TB2 Terminals .....	14
<b>Configuring the ACM-8RF</b> .....	<b>15</b>
Address Switches - SW1 and SW2 .....	15
Relay Assignment DIP Switch - SW3.....	15
Mode Select Switch - SW4 .....	16
<b>Mounting in the ABS-8RF Enclosure</b> .....	<b>16</b>
<b>UL Power-limited Wiring Requirements</b> .....	<b>17</b>

## 3. Electrical Ratings

<b>24 VDC</b> .....	<b>19</b>
<b>Relay Contacts</b> .....	<b>19</b>
<b>Data Communications Port</b> .....	<b>19</b>
<b>Power Requirements</b> .....	<b>19</b>

## Appendix A: MS-5210UD

<b>Capabilities</b> .....	<b>21</b>
<b>FACP Activations</b> .....	<b>22</b>
Alarm Only Activation.....	22
Alarm and Trouble Activation .....	23
<b>Application Example #1</b> .....	<b>24</b>
<b>Application Example #2</b> .....	<b>25</b>
<b>Application Example #3</b> .....	<b>26</b>
<b>Application Example #4</b> .....	<b>28</b>

**Appendix B: MS-9200**

**Capabilities** .....31  
**Testing**.....31  
**Wiring** .....31  
**FACP Activations** .....32  
    Alarm Only Activation .....32  
    Alarm and Trouble Activation.....33

**Appendix C: MS-9600**

**Capabilities** .....37  
**Testing**.....37  
**Wiring** .....37  
**Configuration** .....38  
    Setting Rotary Switches .....38  
    Mode Select .....39  
        Alarm Only or Alarm/Trouble Mode .....39  
        Receive Only or Receive/Transmit Mode.....39  
    Setting the DIP Switches .....40  
        Alarm Only Activation.....40  
        Alarm and Trouble Activation .....41  
    Multiple ACM-8RFs .....42

# 1. Introduction

## General

The ACM-8RF Relay Control Module contains eight high current (5 amps) Form-C relays. The module interfaces to host Fire•Lite control panels which employ an EIA-485 communications bus and may be connected to the bus up to 6,000 feet away from the host control panel.

Typically, each relay is assigned to a zone on the host fire alarm control panel. The relays may be triggered by either a zone alarm (activation) or zone trouble. The relays may also take on special functions depending upon the host panel. Refer to the Appendices for additional information.

The ACM-8RF Relay Control Module may be used in combination with the following products on the same EIA-485 bus circuit:

- AFM/ACM Series LED annunciators
- LDM Series graphic annunciators
- UDACT-F (Universal Digital Alarm Communicator/Transmitter)
- LED-10 Annunciator

EIA-485 bus compatible accessories are designed to provide maximum flexibility to system configurations. Examples include multiple remote LED annunciators with customized labels per corresponding area or function, multiple remote graphic annunciators that illustrate building layout and floor plans, remote DACTs for strategic mounting location near telephone equipment plus remote high current switching relays for such purposes as fan and damper control, elevator recall and door releasing.

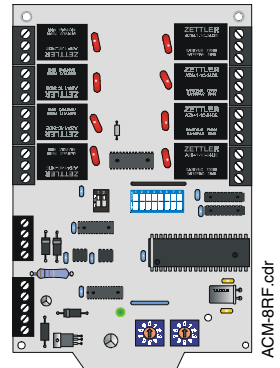

## Mounting

The ACM-8RF module will mount to an ABS-8RF backbox. A blank faceplate is provided with the backbox.

The CAB-3F Series cabinets, with CHS-4L or CHS-4F chassis, may also be used to house several ACM-8RFs.

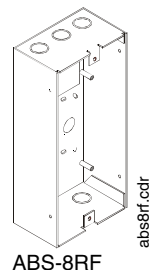

# Features

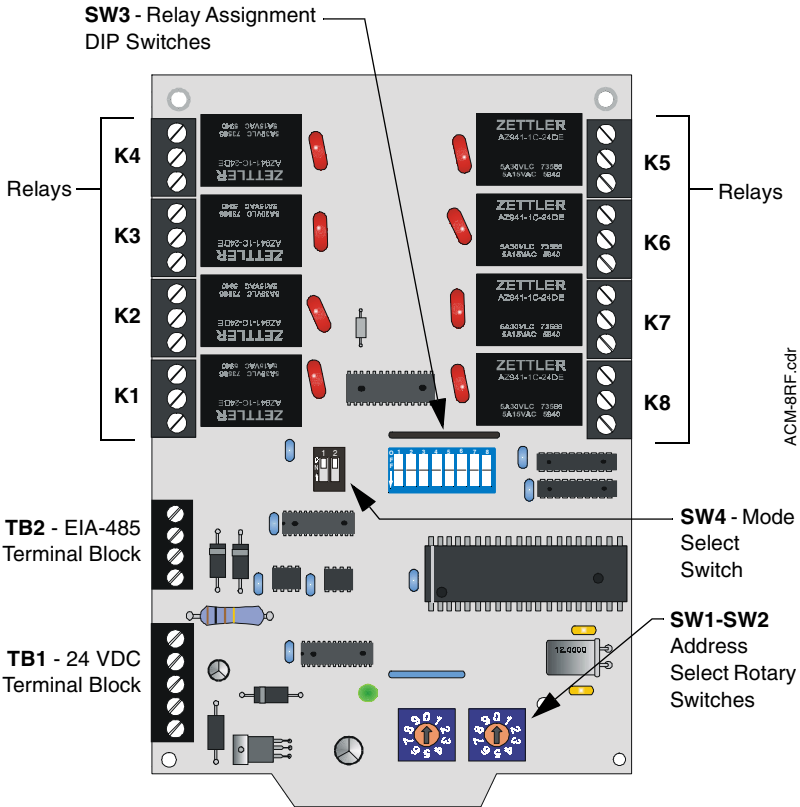

Figure 1 ACM-8RF Features

## Relays

The Relay Control Module provides eight Form-C relays with 5 amp contacts @ 125 VAC (resistive) or 30 VDC (resistive) and 2 amps at 125 VAC inductive). The relay contacts are gold plated silver alloy for medium duty switching and are not intended for motor control or pilot duty. Wiring to the relays is via sturdy removable terminal blocks.

## 24 VDC Power and Earth Ground

Wiring to removable terminal block TB1 is for 24 VDC power-limited, regulated, nonresettable power from the host FACP or a compatible UL listed battery backed power supply such as the Fire•Lite FCPS-24F. This terminal block may be used to daisy chain the 24 VDC to other ACM-8RFs or EIA-485 Fire•Lite compatible devices.



## EIA-485 Communications

Wiring to removable terminal block TB2 is for communications over the EIA-485 bus. The bus carries commands and data sent between the host FACP and ACM-8RFs. The EIA-485 circuit is power-limited. The host FACP supervises devices wired to the EIA-485 bus.

A maximum of 32 ACM-8RFs may be connected to the FACP's EIA-485 bus, but if other types of devices are also connected to the bus, the maximum number of ACM-8RFs must be reduced by the total of such devices.

## Address Switches

Two rotary BCD (Binary Coded Decimal) switches, located on the lower right of the module, are used to set the ACM-8RF system address. SW1 represents the 'tens' position and SW2 represents the 'ones' position of the address setting.

## Relay Function Selection

DIP switch SW3 is used to program the assignment of each ACM-8RF relay to either a zone function (such as zone alarm or zone trouble triggering) or to a system function (such as system alarm, system trouble, system supervisory, signal silence, pre-alarm or AC fail). Be certain to review the Appendices for information on SW3 switch settings for specific FACPs and the operation and options available to each host FACP.

## Mode Selection

DIP switch SW4 is used to set the mode of operation for the ACM-8RF as follows:

- #1 sets Alarm activation or Alarm/Trouble activation mode.
- #2 sets Receive or Receive/Transmit mode.

## Related Documentation

Further details about products referenced in this document can be found in the manuals for the particular fire alarm control panel and components.

Product	Part Number
MS-5210UD Fire Alarm Control Panel Instruction Manual	50193
MS-9200 Fire Alarm Control Panel Instruction Manual	51003
MS-9600 Fire Control Panel Instruction Manual	51335
LED-10 Remote Fire Annunciator	50400
FCPS-24F Instruction Manual	50079
UDACT-F Instruction Manual	50049
CAB-3F Series Cabinets	15391

**Table 1 Related Documentation**

**NOTES**

## 2. Installation

### Mounting the Enclosure.

Select and remove the appropriate knockout(s) on the ABS-8RF enclosure.

Securely mount the enclosure.

Ground the enclosure to a solid electrical ground per NEC Article 250.

Pull all wiring into the enclosure (refer to "UL Power-limited Wiring Requirements" on page 17).

### Wiring the Power Terminal Blocks

24 VDC power supplied by the host control panel or external power supply must be regulated and power-limited. This power is inherently supervised (loss of power also results in a communication failure at the control panel).

- Limit the total wire resistance to 10 ohms.
- Connect 24 VDC power from FACP or Power Supply to TB1-3 (+) and TB1-4 (-).
- Connect earth ground (TB1-1 EARTH) to a mounting screw on the backbox or cabinet.

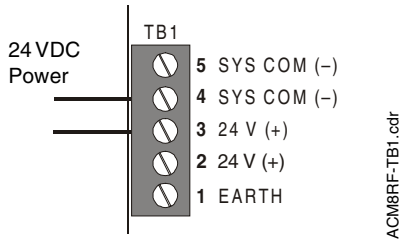

Figure 2 24 VDC Power & Earth Ground Terminals - TB1

Wiring of multiple modules.

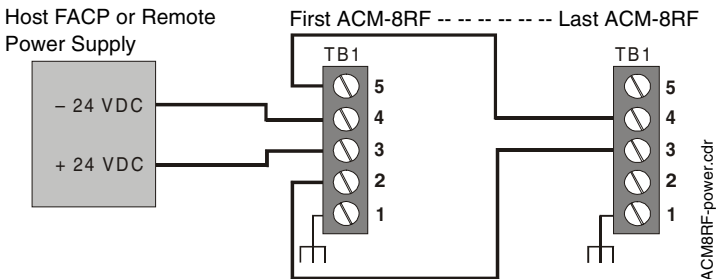

Figure 3 Multiple Module Wiring

# Wiring the Relay Terminal Blocks

The ACM-8RF provides eight relays with Form-C contacts rated for 5 amps.

**Note:** Wiring from these relays is not supervised.

The terminal assignments are illustrated below. For information on wiring limitations, refer to "UL Power-limited Wiring Requirements" on page 17.

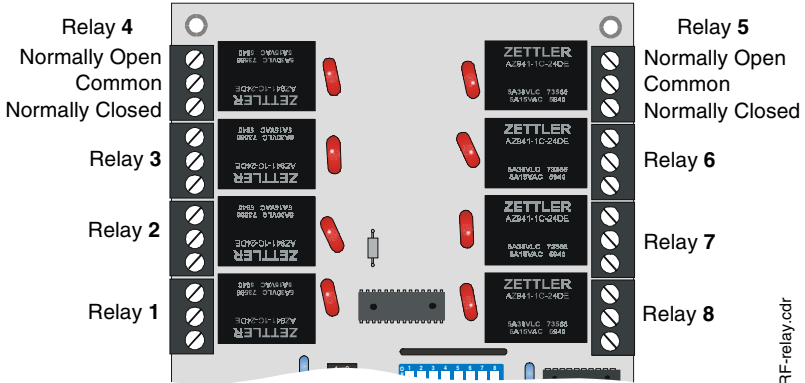

ACM8RF-relay.cdr

**Note:** All Relays have the same terminal assignment position as those on relay #4 & #5

**Figure 4 Relay Terminal Assignments**

## Wiring the EIA-485 Terminal Blocks

Communications between the Fire Alarm Control Panel and the ACM-8RF is accomplished over a two-wire EIA-485 serial communications bus which must be power-limited. Communications between the host FACP and ACM-8RFs is supervised by the fire alarm control panel.

### Wiring Specifications

- The EIA-485 circuit cannot be T-tapped; it must be wired in a continuous fashion from the control panel to the ACM-8RFs.
- The maximum wiring distance between the panel and ACM-8RFs is 6,000 feet.
- The wiring must be a 18 AWG to 14 AWG twisted shielded pair cable having a characteristic impedance of 120 ohms, +/- 20%.
- Limit the total wire resistance to 100 ohms.
- Do not run cable adjacent to, or in the same conduit as, 120 volts AC service, noisy electrical circuits that are powering mechanical bells or horns, audio circuits above 25 VRMS, motor control circuits, or SCR power circuits.

**Note:** Never use the EIA-485 shield for grounding purposes. Terminate the EIA-485 shield at the Fire Alarm Control Panel only.

Standard Annealed Copper Wire						
Wire Size A.W.G	Diameter in Mils	Cross Section		Ohms per 1000 feet		Pounds per 1000 feet
		Circ. Mils	Sq. Inch	@ 77°F.	@ 149°F.	
14	64	4110	0.00323	2.85	2.97	12.4
16	51	2580	0.00203	4.09	4.73	7.82
18	40	1620	0.00128	6.51	7.51	4.92

**Table 2 Wire Specifications**

### EIA-485 Shield in Conduit

When the EIA-485 wiring is in conduit, connect the shield to system common. The shield can enter the cabinet, but must be insulated from the cabinet (no electrical contact). Between ACM-8RFs, wire-nut multiple shields together (which can be inside of the respective ACM-8RF enclosure but ensure that the shield does not contact earth ground).

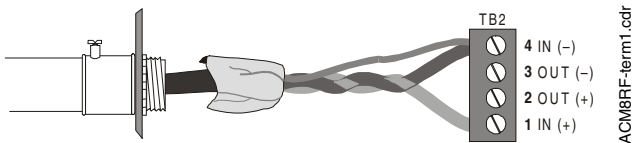

**Figure 5 Terminating the Shield in Conduit**

### EIA-485 Shield Not in Conduit

When the EIA-485 wiring is not in conduit, terminate the shield at the outside of the FACP cabinet. Do not allow the shield to enter or even touch the cabinet housing the ACM-8RFs. Between ACM-8RFs, wire-nut multiple shields together *outside* of the respective enclosures. Ensure that the shield does not touch earth ground at any junction points.

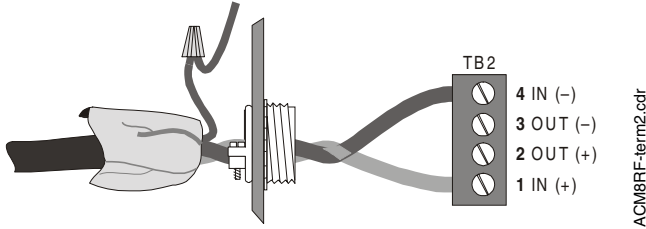

Figure 6 Terminating the Shield with No Conduit

### EIA-485 - TB2 Terminals

Wire as shown below:

**Note:** Leave a 120 ohm ELR installed across the EIA-485 Out terminals at the last ACM-8RF on the circuit (see below). All other ACM-8RFs should not have a resistor installed.

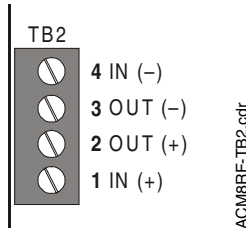

Figure 7 EIA-485 Terminal Block - TB2

Multiple wiring of EIA-485 circuits

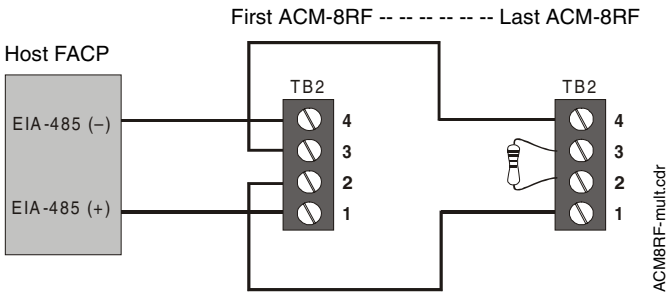

Figure 8 Wiring Multiple ACM-8RFs - EIA-485

# Configuring the ACM-8RF

## Address Switches - SW1 and SW2

It is critical to the operation of the relays that the address switches be set correctly.

To set the relay module for address '01', position the arrow on SW1 (tens) so it points to **0** and position the arrow on SW2 (ones) so it points to **1**.

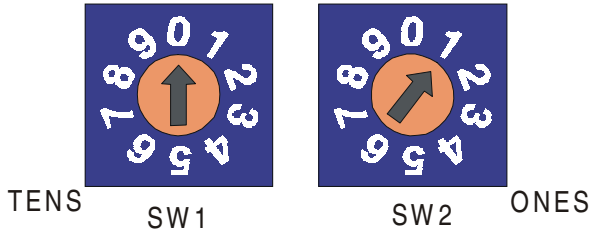

ACM8RF-SW1-2.cdr

Figure 9 Address Switches SW1 & SW2

## Relay Assignment DIP Switch - SW3

Check the Appendices for information on SW3 switch settings for specific FACPs and the operation and options available to each host FACP. The following illustration provides details on DIP switch placement in the On and OFF position.

Side View of Switch  
Shown in the OFF  
Position

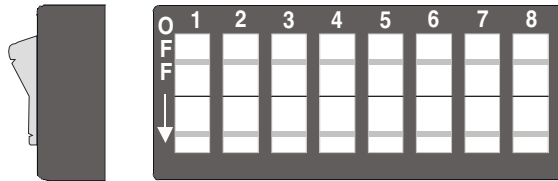

ACM8RF-SW3.cdr

Figure 10 Relay Assignment Switch

## Mode Select Switch - SW4

Set the mode of operation as follows:

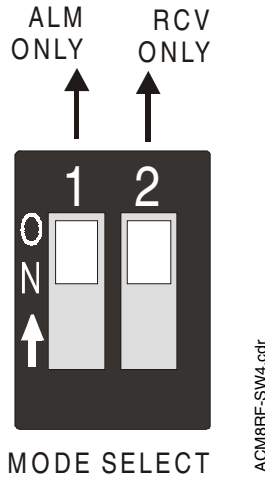

**Figure 11 Mode Select Switch**

- **Switch #1** set to the **ON** position will cause the ACM-8RF relays to trigger only for FACP zone alarm activation.
- **Switch #1** set to the **OFF** position will cause the ACM-8RF relays to trigger for FACP zone alarm and zone trouble activation.
- **Switch #2** set to the **ON** position places the ACM-8RF in 'Receive only' mode. In this mode, the ACM-8RF does not transmit information back to the host FACP.
- **Switch #2** set to the **OFF** position places the ACM-8RF in 'Receive/Transmit' mode. In this mode, the ACM-8RF will transmit supervisory data back to the FACP. The FACP will use this data to acknowledge that the ACM-8RF is properly communicating.

**Note:** It is essential that ACM-8RFs and any other devices wired to the EIA-485 bus and set to the same address not be programmed for receive/transmit mode. Only one EIA-485 device per address may be set for receive/transmit.

## Mounting in the ABS-8RF Enclosure

Place the ACM-8RF in the ABS-8RF backbox. Align the two captive screws on the top of the relay module and the two mounting holes on the bottom of the relay module with the standoffs on the backbox.

**Note:** A solid earth ground connection must be made to one of the top mounting screws in order to provide transient and lightning protection.

Secure with captive screws at top and with two loose screws at bottom. Plug all terminal blocks into their respective sockets. Place and secure faceplate to backbox.



## UL Power-limited Wiring Requirements

Power-limited and nonpower-limited circuit wiring must remain separated in the cabinet. All power-limited circuit wiring must remain at least 0.25" away from any nonpower-limited circuit wiring. Furthermore, all power-limited circuit wiring and nonpower-limited circuit wiring must enter and exit the cabinet through different knockouts and/or conduits. A typical wiring diagram for the ACM-8RF is shown below. In this diagram, relays K1 through K4 are being used for power-limited circuits and relays K5 through K8 for nonpower-limited circuits. Different applications may require different conduit knockouts to be used. Any conduit knockouts may be used provided that the nonpower-limited wiring remain separated from the power-limited wiring.

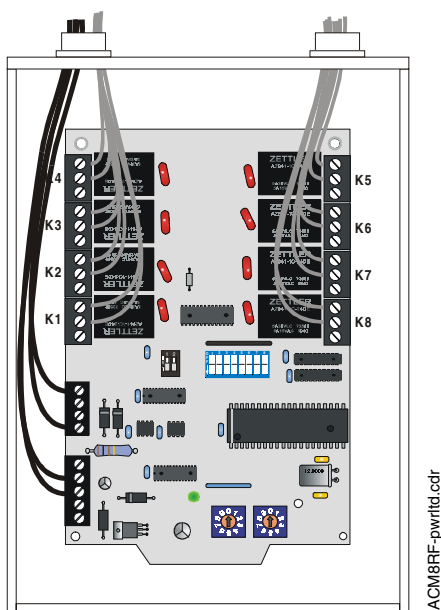

**Figure 12 Typical Wiring Diagram**

Requirements for power-limited and nonpower-limited circuits on the same ACM-8RF module are as follows:

1. If a mix of power-limited and nonpower-limited circuits are connected to relays, skip a set of dry contacts to maintain 0.25" spacing between power-limited and nonpower-limited circuits.
2. If only power-limited or nonpower-limited circuits are being employed, all relays may be used without skipping any for spacing purposes.
3. Relays K1 through K4 may be used to run all power-limited circuits while K5 through K8 are being used to run all non-power-limited circuits.
4. Refer to the Power-limited label located on the FACP door. Make a notation on the label for each circuit being employed as a Nonpower-limited circuit. (Refer to the example on the label).

**NOTES**

# 3. Electrical Ratings

## 24 VDC

Must be power-limited.

Current Draw from 24 VDC Input @ Normal Standby: **0.030 amps**

Maximum current with all output relays activated: **158 mA.**

## Relay Contacts

UL contact ratings are 5 amps @ 125 VAC (resistive) or 30 VDC (resistive) and 2 amps @ 125 VAC (inductive).

## Data Communications Port

Must be power-limited.

EIA-485 operating at: **20 Kbaud**

## Power Requirements

Each ACM-8RF relay module must be accounted for in the power calculations outlined in the respective FACP installation manual. The ACM-8RF draws its power from the control panel and must be considered when calculating the primary and secondary power supply requirements for the system. However, if the current draw dedicated to the ACM-8RF must be calculated as a separate figure (in cases where a separate UL listed power source is used), use the equations below:

Standby Current			
Number of ACM-8RF modules	[ ]	X 0.030	= [ ] amps
Alarm Current			
1.) Number of ACM-8RF modules	[ ]	X 0.030	= [ ] amps
2.) Maximum number of relays which can be activated simultaneously <sup>1</sup>	[ ]	X 0.016	= [ ] amps
<b>Total Alarm Current</b> (sum of 1 & 2)			= [ ] amps

1. The maximum number of simultaneously activated relays depends on system configuration and programming.

**Table 3 Power Requirement Calculations**

**NOTES**

# Appendix A: MS-5210UD

## Capabilities

When installed with an MS-5210UD Fire Alarm Control Panel (FACP), the ACM-8RF Relay Control Modules provide relay activation for each of the ten FACP zones plus special functions. Options exist to allow for alarm only or alarm and trouble activations per zone. Output activation for General Alarm, general trouble, general Supervisory, NAC Fault, AC Fail, System Off Normal, Walktest start and Battery Trouble are also available. Up to 32 ACM-8RF Relay Control Modules may be placed onto the EIA-485 communication bus (if no other devices are installed on the bus).

**CAUTION:** It is vitally important that, following relay programming, all relays be tested for correct activation by triggering zones and/or special functions at the FACP. It should also be noted:

- ACM-8RF Relays will activate during the Alarm Pre-signal Sequence and for Process Monitoring.
- ACM-8RF Relays will not activate during the Alarm Verification Retard and Reset periods.
- ACM-8RF Relays will return to normal if a zone is set for autoresettable operation.

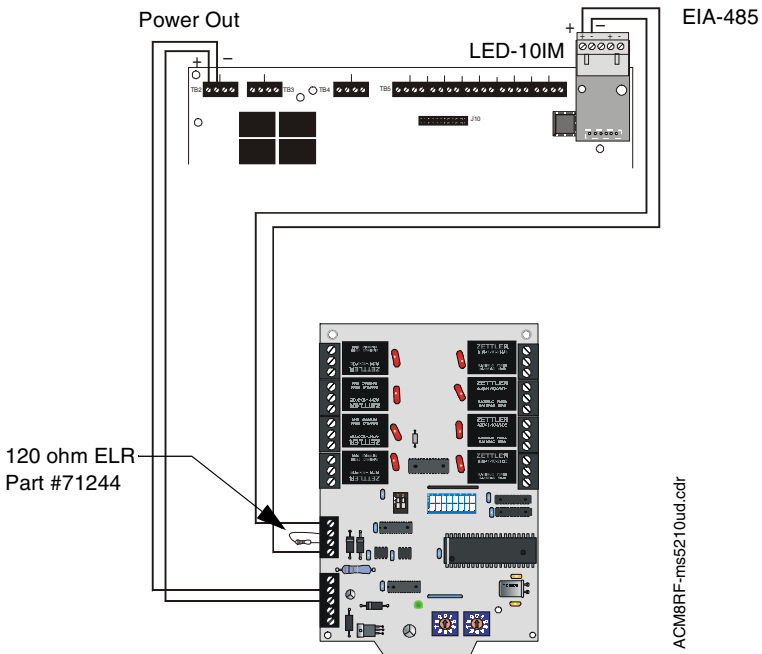

Figure 13 Wiring the ACM-8RF to an MS-5210UD

## FACP Activations

DIP switch SW3 on the ACM-8RF Relay Control Module is used to determine which FACP activations will trigger relays on the Relay Control Module. When installed with an MS-5210UD Fire Alarm Control Panel, use the following tables to set SW3 switches. Note that two tables are provided; one table for alarm only operation (SW4-1 = ON) and one table for alarm and trouble operation (SW4-1 = OFF).

### Alarm Only Activation

Table 4 provides the switch settings for ACM-8RF DIP switch SW3 when configuring the relays to trigger for alarm activation only. Note that a maximum of three ACM-8RFs are required if one relay is to be designated to trigger on any FACP alarm. If a general system alarm relay is not required, two ACM-8RFs may be used to allow individual relay triggering for activation of FACP zones 1 through 10. When using only two ACM-8RFs, be sure to use the switch settings for the 2nd and 3rd ACM-8RF in Table 4. Refer to "Relay Assignment DIP Switch - SW3" on page 15 for information on setting DIP switch SW3.

MS-5210UD Zone	ACM-8RF Relay	SW3 Settings
System Alarm	Relay 1	<b>1st ACM-8RF</b> SW3-1 = ON SW3-5 = ON All others = OFF
Not Used	Relay 2 (not used)	
Not Used	Relay 3 (not used)	
Not Used	Relay 4 (not used)	
Not Used	Relay 5 (not used)	
Not Used	Relay 6 (not used)	
Not Used	Relay 7 (not used)	
Not Used	Relay 8 (not used)	
Z1	Relay 1	<b>2nd ACM-8RF</b> SW3-2 = ON SW3-5 = ON All others = OFF
Z2	Relay 2	
Z3	Relay 3	
Z4	Relay 4	
Z5	Relay 5	
Z6	Relay 6	
Z7	Relay 7	
Z8	Relay 8	
Z9	Relay 1	<b>3rd ACM-8RF</b> SW3-3 = ON SW3-5 = ON All others = OFF
Z10	Relay 2	
n/a	Relay 3 (not used)	
n/a	Relay 4 (not used)	
n/a	Relay 5 (not used)	
n/a	Relay 6 (not used)	
n/a	Relay 7 (not used)	
n/a	Relay 8 (not used)	

**Table 4 SW3 Settings for Alarm Only**

## Alarm and Trouble Activation

Table 5 provides the switch settings for ACM-8RF DIP switch SW3 when configuring the relays to trigger for alarm and trouble activation. Note that a maximum of five ACM-8RFs are required if relays are to be designated to trigger on any FACP status change. If system status relays are not required, three ACM-8RFs may be used to allow individual relay triggering for alarm and trouble activation of FACP zones 1 through 10. When using only three ACM-8RFs, be sure to use the switch settings for the 3rd, 4th and 5th ACM-8RF in Table 5.

MS-5210UD Zone	ACM-8RF Alarm Relay	ACM-8RF Trouble Relay	SW3 Settings
System Status	1=System Alarm	5=System Trouble	<b>1st ACM-8RF</b> SW3-1 = ON SW3-5 = ON All others = OFF
System Status	Relay 2 (not used)	Relay 6 (not used)	
System Status	Relay 3 (not used)	7=System Off Normal	
System Status	Relay 4 (not used)	8=System Supervisory	
System Status	Relay 1 (not used)	5=NAC(s) Fault	<b>2nd ACM-8RF</b> SW3-2 = ON SW3-5 = ON All others = OFF
System Status	Relay 2 (not used)	6=Walktest Start	
System Status	Relay 3 (not used)	7=Battery Fail	
System Status	Relay 4 (not used)	8=AC Fail	
Z1	Relay 1	Relay 5	<b>3rd ACM-8RF</b> SW3-3 = ON SW3-5 = ON All others = OFF
Z2	Relay 2	Relay 6	
Z3	Relay 3	Relay 7	
Z4	Relay 4	Relay 8	
Z5	Relay 1	Relay 5	<b>4th ACM-8RF</b> SW3-4 = ON SW3-5 = ON All others = OFF
Z6	Relay 2	Relay 6	
Z7	Relay 3	Relay 7	
Z8	Relay 4	Relay 8	
Z9	Relay 1	Relay 5	<b>5th ACM-8RF</b> SW3-1 = ON SW3-6 = ON All others = OFF
Z10	Relay 2	Relay 6	
n/a	Relay 3 (not used)	Relay 7 (not used)	
n/a	Relay 4 (not used)	Relay 8 (not used)	

**Table 5 SW3 Settings for Alarm and Trouble**

## Application Example #1

### Zone Alarm Only Activation (no system status relays)

Program the MS-5210UD at Level 3 addresses 02 - 03 for the proper address setting. The address selected must be the highest or maximum address value selected on any annunciator or ACM-8RF connected to the EIA-485 port. (Refer to the Programming Section of the MS-5210UD Instruction Manual).

For this example, only one relay per zone is required and the ACM-8RFs are the only devices on the EIA-485 bus. Since only ACM-8RFs occupy the bus, the address setting for them should be switch SW1 = 0 and switch SW2 = 1. Enter this address into the MS-5210UD Level 3 addresses 02 - 03.

Since each ACM-8RF module contains eight relays, two ACM-8RF modules are required for 10 zones. Refer to the following chart for switch settings:

MS-5210UD Zone	ACM-8RF Relay	Switch Settings
Z1	Relay 1	<b>1st ACM-8RF</b> SW1=0; SW2=1 (Address '01') SW3-2 = ON; SW3-5 = ON All other SW3s = OFF SW4-1=ON; SW4-2=ON
Z2	Relay 2	
Z3	Relay 3	
Z4	Relay 4	
Z5	Relay 5	
Z6	Relay 6	
Z7	Relay 7	
Z8	Relay 8	
Z9	Relay 1	<b>2nd ACM-8RF</b> SW1=0, SW2=1 (Address '01') SW3-3 = ON; SW3-5 = ON All other SW3s = OFF SW4-1=ON; SW4-2=OFF
Z10	Relay 2	
n/a	Relay 3	
n/a	Relay 4	
n/a	Relay 5	
n/a	Relay 6	
n/a	Relay 7	
n/a	Relay 8	

**Table 6 Settings for Zone Alarm Activation**



## Application Example #2

### Zone Alarm and Trouble Activation (no system status relays)

Program the MS-5210UD at Level 3 addresses 02 - 03 for the proper address setting. The address selected must be the highest or maximum address value selected on any annunciator or ACM-8RF connected to the EIA-485 port. (Refer to the Programming Section of the MS-5210UD Instruction Manual).

For this example, two relays per zone are required for alarm and trouble, therefore, three ACM-8RFs are necessary. In this example, the ACM-8RFs are the only devices on the EIA-485 bus. Set the ACM-8RF address switches so that SW1 = 0 and SW2 = 1 on *each* of the three ACM-8RFs. Enter this address into the MS-5210UD Level 3 addresses 02 - 03. Refer to the following chart for switch settings:

MS-5210UD Zone	ACM-8RF Alarm Relay	ACM-8RF Trouble Relay	Switch Settings
Z1	Relay 1	Relay 5	<b>1st ACM-8RF</b> SW1=0; SW2=1 (Address '01') SW3-3 = ON; SW3-5 = ON All other SW3s = OFF SW4-1=OFF; SW4-2=ON
Z2	Relay 2	Relay 6	
Z3	Relay 3	Relay 7	
Z4	Relay 4	Relay 8	
Z5	Relay 1	Relay 5	<b>2nd ACM-8RF</b> SW1=0; SW2=1 (Address '01') SW3-4 = ON; SW3-5 = ON All other SW3s = OFF SW4-1=OFF; SW4-2=ON
Z6	Relay 2	Relay 6	
Z7	Relay 3	Relay 7	
Z8	Relay 4	Relay 8	
Z9	Relay 1	Relay 5	<b>3rd ACM-8RF</b> SW1=0; SW2=1 (Address '01') SW3-1 = ON; SW3-6 = ON All other SW3s = OFF SW4-1=OFF; SW4-2=OFF
Z10	Relay 2	Relay 6	
n/a	Relay 3	Relay 7	
n/a	Relay 4	Relay 8	

**Table 7 Settings for Zone Alarm and Trouble Activation**

## Application Example #3

### Two LED-10 Annunciators and 10 Alarm Only Relays (no system status relays)

Program the MS-5210UD at Level 3 addresses 02 - 03 for the proper address setting. The address selected must be the highest or maximum address value selected on any annunciator or ACM-8RF connected to the EIA-485 port. (Refer to the Programming Section of the MS-5210UD Instruction Manual).

For this example, only one relay per MS-5210UD zone is required and the ACM-8RFs are sharing the EIA-485 bus with two LED-10s. Since ACM-8RFs are sharing the bus with two other devices, the address setting for the ACM-8RFs should be switches SW1 = 0 and SW2 = 3. Enter this address into the MS-5210UD Level 3 addresses 02 - 03.

Since each ACM-8RF module contains eight relays, two ACM-8RF modules are required for 10 zones. Refer to the following chart for switch settings:

MS-5210UD Zone	ACM-8RF Relay	Switch Settings
Z1	Relay 1	<b>1st ACM-8RF</b> SW1=0; SW2=3 (Address '03') SW3-2 = ON; SW3-5 = ON All other SW3s = OFF SW4-1=ON; SW4-2=ON
Z2	Relay 2	
Z3	Relay 3	
Z4	Relay 4	
Z5	Relay 5	
Z6	Relay 6	
Z7	Relay 7	
Z8	Relay 8	
Z9	Relay 1	<b>2nd ACM-8RF</b> SW1=0, SW2=3 (Address '03') SW3-3 = ON; SW3-5 = ON All other SW3s = OFF SW4-1=ON; SW4-2=OFF
Z10	Relay 2	
n/a	Relay 3	
n/a	Relay 4	
n/a	Relay 5	
n/a	Relay 6	
n/a	Relay 7	
n/a	Relay 8	

**Table 8 Settings for Zone Alarm Activation with LED-10s**



## Application Example #4

### **Two LED-10 Annunciators, 10 Alarm Only Relays and 20 Alarm/Trouble Relays (no system status relays)**

Program the MS-5210UD at Level 3 addresses 02 - 03 for the proper address setting. The address selected must be the highest or maximum address value selected on any annunciator or ACM-8RF connected to the EIA-485 port. (Refer to the Programming Section of the MS-5210UD Instruction Manual).

For this example, only one relay per MS-5210UD zone is required for the first set of Alarm Only Relays, two relays per MS-5210UD zone is required for the second set of Alarm and Trouble Relays and the ACM-8RFs are sharing the EIA-485 bus with two LED-10s. Since ACM-8RFs are sharing the bus with two other devices, the address setting for the first set of ACM-8RFs should be switches SW1 = 0 and SW2 = 3 for address '03'. The address setting for the second set of ACM-8RFs should be switches SW1 = 0 and SW2 = 4 for address '04'. Enter this highest address into the MS-5210UD Level 3 addresses 02 - 03.

*Continued on the next page...*

Since each ACM-8RF module contains eight relays, two ACM-8RF modules are required for 10 zones of Alarm Only Relays and three ACM-8RF modules are required for 10 zones of Alarm and Trouble Relays (20 relays required).

MS-5210UD Zone	ACM-8RF Alarm Relay	ACM-8RF Trouble Relay	Switch Settings
Z1	Relay 1		<b>1st ACM-8RF</b> SW1=0; SW2=3 (Address '03') SW3-2 = ON; SW3-5 = ON All other SW3s = OFF SW4-1=ON; SW4-2=ON
Z2	Relay 2		
Z3	Relay 3		
Z4	Relay 4		
Z5	Relay 5		
Z6	Relay 6		
Z7	Relay 7		
Z8	Relay 8		
Z9	Relay 1		<b>2nd ACM-8RF</b> SW1=0; SW2=3 (Address '03') SW3-3 = ON; SW3-5 = ON All other SW3s = OFF SW4-1=ON; SW4-2=OFF
Z10	Relay 2		
n/a	Relay 3		
n/a	Relay 4		
n/a	Relay 5		
n/a	Relay 6		
n/a	Relay 7		
n/a	Relay 8		
Z1	Relay 1	Relay 5	<b>3rd ACM-8RF</b> SW1=0; SW2=4 (Address '04') SW3-3 = ON; SW3-5 = ON All other SW3s = OFF SW4-1=OFF; SW4-2=ON
Z2	Relay 2	Relay 6	
Z3	Relay 3	Relay 7	
Z4	Relay 4	Relay 8	
Z5	Relay 1	Relay 5	<b>4th ACM-8RF</b> SW1=0; SW2=4 (Address '04') SW3-4 = ON; SW3-5 = ON All other SW3s = OFF SW4-1=OFF; SW4-2=ON
Z6	Relay 2	Relay 6	
Z7	Relay 3	Relay 7	
Z8	Relay 4	Relay 8	
Z9	Relay 1	Relay 5	<b>5th ACM-8RF</b> SW1=0; SW2=4 (Address '04') SW3-1 = ON; SW3-6 = ON All other SW3s = OFF SW4-1=OFF; SW4-2=OFF
Z10	Relay 2	Relay 6	
n/a	Relay 3	Relay 7	
n/a	Relay 4	Relay 8	

**Table 9 Settings for Zone Alarm and Trouble Activation with LED-10s**

The figure below is provided as an application example of using two LED-10s and two ACM-8RFs. It is not intended to be used as a wiring diagram.

Refer to Figure 13 on page 21, or the appropriate instruction manuals, for detailed wiring information.

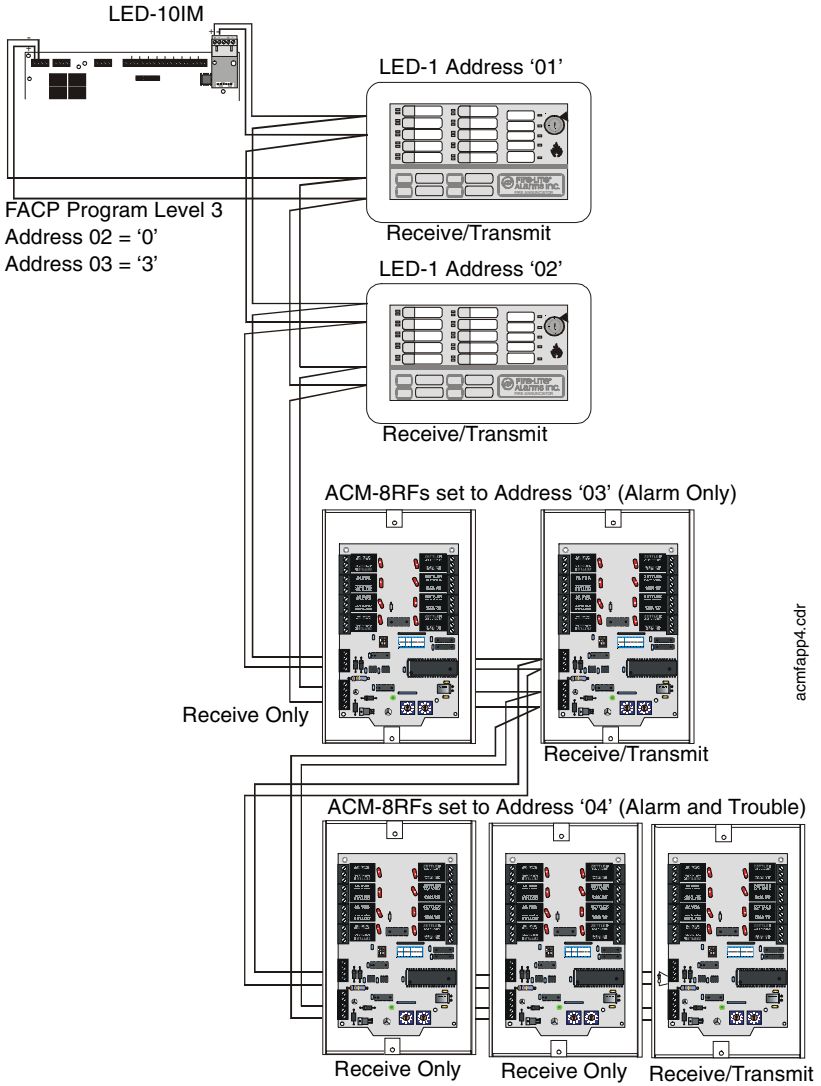

Figure 15 Two LED-10s and Five ACM-8RFs

# Appendix B: MS-9200

## Capabilities

When installed with an MS-9200 Fire Alarm Control Panel (FACP), the ACM-8RF Relay Control Modules provide relay activation (alarm only or alarm/trouble) for each of the 56 FACP zones. Output activation for System Alarm, System Trouble, Alarm Silence, Walktest, Supervisory, NAC Fault, Battery Trouble and AC Fail are also available. Up to 32 ACM-8RF Relay Control Modules may be placed onto the EIA-485 communication bus (if no other devices are installed on the bus).

## Testing

It is vitally important that, following relay programming, all relays be tested for correct activation by triggering zones and/or special functions at the FACP. It should also be noted:

- ACM-8RF relays will activate during the Alarm Pre-signal Sequence.
- ACM-8RF relays will not activate during the Alarm Verification Retard and Reset periods.

## Wiring

Wire the AMC-8RF to the MS-9200 control panel as shown below.

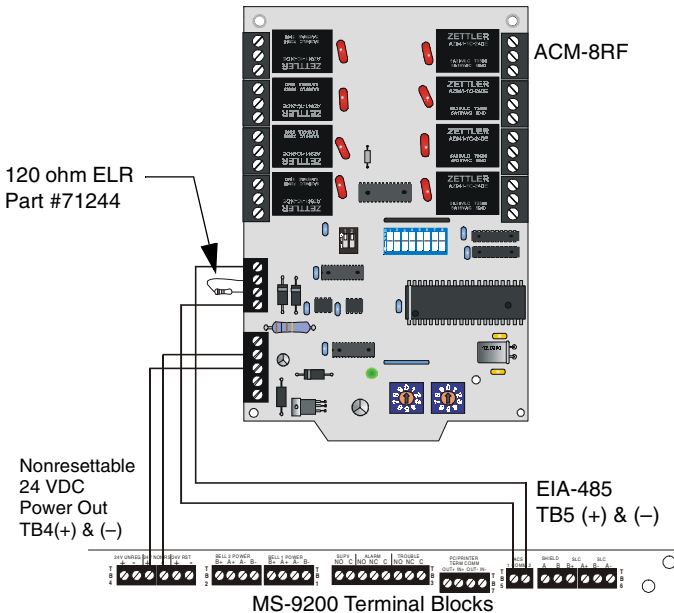

Figure 16 Wiring ACM-8RF to MS-9200

## FACP Activations

DIP switch SW3 on the ACM-8RF Relay Control Module is used to determine which FACP activations will trigger relays on the ACM-8RF. Use the following tables to set SW3 switches. The Address Select Rotary Switches on all ACM-8RFs must be set to address '01' (SW1 = 0, SW2 = 1).

Two tables are provided, one table for alarm only operation (SW4-1 = ON) and one table for alarm and trouble operation (SW4-1 = OFF).

### Alarm Only Activation

Table 10 provides the switch settings for ACM-8RF DIP switch SW3 when configuring the relays to trigger for MS-9200 alarm activation only. A maximum of eight ACM-8RFs are required if one relay is to be designated to trigger on any FACP zone alarm. If a general system alarm relay is not required, seven ACM-8RFs may be used to allow individual relay triggering for alarm activation of FACP zones 1 through 56. When using seven ACM-8RFs, be sure to use the switch settings for the 2nd through the eighth ACM-8RF in Table 10.

MS-9200 Zone	ACM-8RF Relay	ACM-8RF SW3 Settings	MS-9200 Zone	ACM-8RF Relay	SW3 Settings
System Alarm	Relay 1	<b>1st ACM-8RF</b> SW3-1 = ON SW3-5 = ON All others = OFF	Z25	Relay 1	<b>5th ACM-8RF</b> SW3-1 = ON SW3-6 = ON All others = OFF
Not Used	Relay 2		Z26	Relay 2	
Not Used	Relay 3		Z27	Relay 3	
Not Used	Relay 4		Z28	Relay 4	
Not Used	Relay 5		Z29	Relay 5	
Not Used	Relay 6		Z30	Relay 6	
Not Used	Relay 7		Z31	Relay 7	
Not Used	Relay 8		Z32	Relay 8	
Z1	Relay 1	<b>2nd ACM-8RF</b> SW3-2 = ON SW3-5 = ON All others = OFF	Z33	Relay 1	<b>6th ACM-8RF</b> SW3-2 = ON SW3-6 = ON All others = OFF
Z2	Relay 2		Z34	Relay 2	
Z3	Relay 3		Z35	Relay 3	
Z4	Relay 4		Z36	Relay 4	
Z5	Relay 5		Z37	Relay 5	
Z6	Relay 6		Z38	Relay 6	
Z7	Relay 7		Z39	Relay 7	
Z8	Relay 8		Z40	Relay 8	
Z9	Relay 1	<b>3rd ACM-8RF</b> SW3-3 = ON SW3-5 = ON All others = OFF	Z41	Relay 1	<b>7th ACM-8RF</b> SW3-3 = ON SW3-6 = ON All others = OFF
Z10	Relay 2		Z42	Relay 2	
Z11	Relay 3		Z43	Relay 3	
Z12	Relay 4		Z44	Relay 4	
Z13	Relay 5		Z45	Relay 5	
Z14	Relay 6		Z46	Relay 6	
Z15	Relay 7		Z47	Relay 7	
Z16	Relay 8		Z48	Relay 8	
Z17	Relay 1	<b>4th ACM-8RF</b> SW3-4 = ON SW3-5 = ON All others = OFF	Z49	Relay 1	<b>8th ACM-8RF</b> SW3-4 = ON SW3-6 = ON All others = OFF
Z18	Relay 2		Z50	Relay 2	
Z19	Relay 3		Z51	Relay 3	
Z20	Relay 4		Z52	Relay 4	
Z21	Relay 5		Z53	Relay 5	
Z22	Relay 6		Z54	Relay 6	
Z23	Relay 7		Z55	Relay 7	
Z24	Relay 8		Z56	Relay 8	

**Table 10 SW3 Settings for Alarm Only**



## Alarm and Trouble Activation

Table 11 provides the switch settings for ACM-8RF DIP switch SW3 when configuring the relays to trigger for MS-9200 alarm and trouble activation. A maximum of 16 ACM-8RFs are required if relays are to be designated to trigger on any FACP status change. If system status relays are not required, 14 ACM-8RFs may be used to allow individual relay triggering for alarm and trouble activation of FACP zones 1 through 56. When using 14 ACM-8RFs, be sure to use the switch settings for the 3rd through the 16th ACM-8RF in Table 11.

When the MS-9200 is programmed for an annunciator without a UDACT-F, the first 16 relays will be assigned to the status functions listed in the table below.

If the MS-9200 is programmed for an annunciator and a UDACT-F, the first 16 relays will be assigned to the status functions listed in Table 12 on page 35.

MS-9200 Zone	ACM-8RF Alarm	ACM-8RF Trouble	Switch Settings
System Status	1=System Alarm	5=System Trouble	<b>1st ACM-8RF</b> SW3-1 = ON; SW3-5 = ON All other SW3s = OFF
System Status	Relay 2 (not used)	6=Alarm Silence	
System Status	Relay 3 (not used)	Relay 7 (not used)	
System Status	Relay 4 (not used)	Relay 8 (not used)	
System Status	Relay 1 (not used)	5= Supervisory	<b>2nd ACM-8RF</b> SW3-2 = ON; SW3-5 = ON All other SW3s = OFF
System Status	Relay 2 (not used)	Relay 6 (not used)	
System Status	Relay 3 (not used)	Relay 7 (not used)	
System Status	Relay 4 (not used)	8= Panel Trouble	
Z1	Relay 1	Relay 5	<b>3rd ACM-8RF</b> SW3-3 = ON; SW3-5 = ON All other SW3s = OFF
Z2	Relay 2	Relay 6	
Z3	Relay 3	Relay 7	
Z4	Relay 4	Relay 8	
Z5	Relay 1	Relay 5	<b>4th ACM-8RF</b> SW3-4 = ON; SW3-5 = ON All other SW3s = OFF
Z6	Relay 2	Relay 6	
Z7	Relay 3	Relay 7	
Z8	Relay 4	Relay 8	
Z9	Relay 1	Relay 5	<b>5th ACM-8RF</b> SW3-1 = ON; SW3-6 = ON All other SW3s = OFF
Z10	Relay 2	Relay 6	
Z11	Relay 3	Relay 7	
Z12	Relay 4	Relay 8	
Z13	Relay 1	Relay 5	<b>6th ACM-8RF</b> SW3-2 = ON; SW3-6 = ON All other SW3s = OFF
Z14	Relay 2	Relay 6	
Z15	Relay 3	Relay 7	
Z16	Relay 4	Relay 8	
Z17	Relay 1	Relay 5	<b>7th ACM-8RF</b> SW3-3 = ON; SW3-6 = ON All other SW3s = OFF
Z18	Relay 2	Relay 6	
Z19	Relay 3	Relay 7	
Z20	Relay 4	Relay 8	

**Table 11 SW3 Settings for Alarm and Trouble**

MS-9200 Zone	ACM-8RF Alarm	ACM-8RF Trouble	Switch Settings
Z21	Relay 1	Relay 5	<b>8th ACM-8RF</b> SW3-4 = ON; SW3-6 = ON All other SW3s = OFF
Z22	Relay 2	Relay 6	
Z23	Relay 3	Relay 7	
Z24	Relay 4	Relay 8	
Z25	Relay 1	Relay 5	<b>9th ACM-8RF</b> SW3-1 = ON; SW3-7 = ON All other SW3s = OFF
Z26	Relay 2	Relay 6	
Z27	Relay 3	Relay 7	
Z28	Relay 4	Relay 8	
Z29	Relay 1	Relay 5	<b>10th ACM-8RF</b> SW3-2 = ON; SW3-7 = ON All other SW3s = OFF
Z30	Relay 2	Relay 6	
Z31	Relay 3	Relay 7	
Z32	Relay 4	Relay 8	
Z33	Relay 1	Relay 5	<b>11th ACM-8RF</b> SW3-3 = ON; SW3-7 = ON All other SW3s = OFF
Z34	Relay 2	Relay 6	
Z35	Relay 3	Relay 7	
Z36	Relay 4	Relay 8	
Z37	Relay 1	Relay 5	<b>12th ACM-8RF</b> SW3-4 = ON; SW3-7 = ON All other SW3s = OFF
Z38	Relay 2	Relay 6	
Z39	Relay 3	Relay 7	
Z40	Relay 4	Relay 8	
Z41	Relay 1	Relay 5	<b>13th ACM-8RF</b> SW3-1 = ON; SW3-8 = ON All other SW3s = OFF
Z42	Relay 2	Relay 6	
Z43	Relay 3	Relay 7	
Z44	Relay 4	Relay 8	
Z45	Relay 1	Relay 5	<b>14th ACM-8RF</b> SW3-2 = ON; SW3-8 = ON All other SW3s = OFF
Z46	Relay 2	Relay 6	
Z47	Relay 3	Relay 7	
Z48	Relay 4	Relay 8	
Z49	Relay 1	Relay 5	<b>15th ACM-8RF</b> SW3-3 = ON; SW3-8 = ON All other SW3s = OFF
Z50	Relay 2	Relay 6	
Z51	Relay 3	Relay 7	
Z52	Relay 4	Relay 8	
Z53	Relay 1	Relay 5	<b>16th ACM-8RF</b> SW3-4 = ON; SW3-8 = ON All other SW3s = OFF
Z54	Relay 2	Relay 6	
Z55	Relay 3	Relay 7	
Z56	Relay 4	Relay 8	

Table 11 SW3 Settings for Alarm and Trouble

Status functions of first 16 relays if the FACP has a UDACT-F installed.

MS-9200 Zone	ACM-8RF Alarm Relay	ACM-8RF Trouble Relay	SW3 Settings
System Status	1 System Alarm	5= System Trouble	<b>1st ACM-8RF</b> SW3-1 = ON SW3-5 = ON All others = OFF
System Status	Relay 2 (not used)	6=Alarm Silence	
System Status	Relay 3 (not used)	7=Walk Test	
System Status	Relay 4 (not used)	8=Supervisory	
System Status	Relay 1 (not used)	5=NAC Fail	<b>2nd ACM-8RF</b> SW3-2 = ON SW3-5 = ON All others = OFF
System Status	Relay 2 (not used)	Relay 6 (not used)	
System Status	Relay 3 (not used)	7=Battery Trouble	
System Status	Relay 4 (not used)	8=AC Fail	

**Table 12 Status Relays (with UDACT-F)**

**NOTES**

# Appendix C: MS-9600

## Capabilities

When installed with an MS-9600 Fire Alarm Control Panel (FACP), the ACM-8RF Relay Control Modules provide relay activation (alarm only or alarm/trouble) for: each of the 99 FACP zones; the two NACs; each of the 159 modules and 159 detectors on both SLC loops. Output activation for System Alarm, System Trouble, Alarm Silence, Walktest, Supervisory, NAC Fault, Battery Trouble and AC Fail are also available. Up to 32 ACM-8RF Relay Control Modules may be placed onto the EIA-485 communication bus (if no other devices are installed on the bus).

## Testing

It is vitally important that, following relay programming, all relays be tested for correct activations by triggering zones, points and special functions at the FACP. It should also be noted:

- ACM-8RF relays will activate during the Alarm Pre-signal Sequence.
- ACM-8RF relays will not activate during the Alarm Verification Retard and Reset periods

## Wiring

Wire the ACM-8RF to the MS-9600 control panel as shown below.

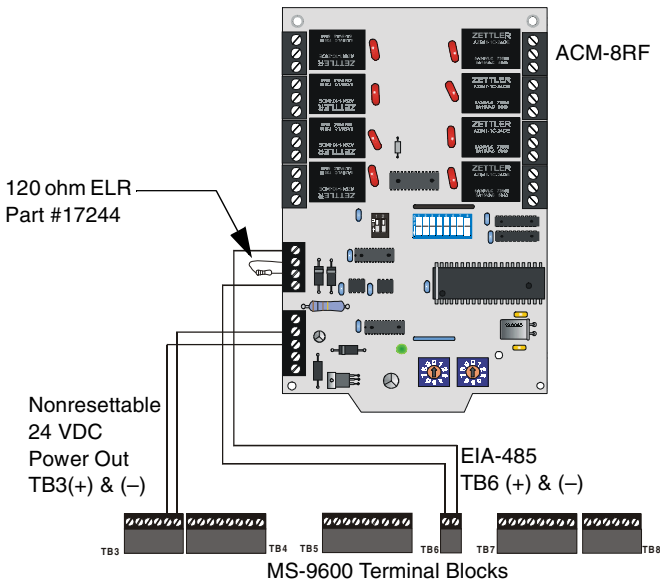

Figure 17 Wiring ACM-8RF to MS-9600

# Configuration

## Setting Rotary Switches

The Address Select Rotary Switches (SW1 & SW2) are used to determine which FACP annunciator address will trigger relays on the ACM-8RF. Use the following table to set these switches. Refer to "Address Switches - SW1 and SW2" on page 15 for information on setting these switches.

M = Module    D = Detector

FACP Address	SW1	SW2	Relay Activation for:
1	0	1	8 System Points & Zones 1-56
2	0	2	Zones 57-99 & 2 NACs
3	0	3	Loop 1, Address M1 - M64
4	0	4	Loop 2, Address M1 - M64
5	0	5	Loop 1, Address M65 - M128
6	0	6	Loop 2, Address M65 - M128
7	0	7	Loop 1, Address M129 - M159 & Loop 2, Address M129 - M159
8	0	8	Loop 1, Address D1 - D64
9	0	9	Loop 2, Address D1 - D64
10	1	0	Loop 1, Address D65 - D128
11	1	1	Loop 2, Address D65 - D128
12	1	2	Loop 1, Address D129 - D159 & Loop 2, Address D129 - D159
13 - 19	Not Used		
20	2	0	8 System Points & Zones 1-56
21	2	1	Zones 57-99 & 2 NACs
22	2	2	Loop 1, Address M1 - M64
23	2	3	Loop 2, Address M1 - M64
24	2	4	Loop 1, Address M65 - M128
25	2	5	Loop 2, Address M65 - M128
26	2	6	Loop 1, Address M129 - M159 & Loop 2, Address M129 - M159
27	2	7	Loop 1, Address D1 - D64
28	2	8	Loop 2, Address D1 - D64
29	2	9	Loop 1, Address D65 - D128
30	3	0	Loop 2, Address D65 - D128
31	3	1	Loop 1, Address D129 - D159 & Loop 2, Address D129 - D159

**Table 13 SW1 & SW2 Switch Settings**

**Note:** If a UDACT-F is installed and selected in control panel programming, it will automatically assign addresses 20 - 31 to the UDACT-F and disable the selection of these addresses.

## Mode Select

### Alarm Only or Alarm/Trouble Mode

Determine if “alarm only” mode or “alarm/trouble” mode is to be used and set the Mode Select switch SW4-1 as described in "Mode Select Switch - SW4" on page 16 and below.

If “alarm only” is selected, relays 1 to 8 will activate when an alarm signal is received from a zone or point.

Zone or Point	Alarm Signal
1, 9, 17 etc. or 65, 73, 81 etc.	Relay 1
2, 10, 18 etc. or 66, 74, 82 etc.	Relay 2
3, 11, 19 etc. or 67, 75, 83 etc.	Relay 3
4, 12, 20 etc. or 68, 76, 84 etc.	Relay 4
5, 13, 21 etc. or 69, 77, 85 etc.	Relay 5
6, 14, 22 etc. or 70, 78, 86 etc.	Relay 6
7, 15, 23 etc. or 71, 79, 87 etc.	Relay 7
8, 16, 24 etc. or 72, 80, 88 etc.	Relay 8

**Table 14 Alarm Only Setup**

If “alarm/trouble” is selected, then relays 1 to 4 will activate when an alarm signal is received from a zone or point and relays 5 to 8 will activate when a trouble signal is received from a zone or point.

Zone or Point	Alarm Signal	Zone or Point	Trouble Signal
1, 9, 17 etc. or 65, 73, 81 etc.	Relay 1	5, 13, 21 etc. or 69, 77, 85 etc.	Relay 5
2, 10, 18 etc. or 66, 74, 82 etc.	Relay 2	6, 14, 22 etc. or 70, 78, 86 etc.	Relay 6
3, 11, 19 etc. or 67, 75, 83 etc.	Relay 3	7, 15, 23 etc. or 71, 79, 87 etc.	Relay 7
4, 12, 20 etc. or 68, 76, 84 etc.	Relay 4	8, 16, 24 etc. or 72, 80, 88 etc.	Relay 8

**Table 15 Alarm and Trouble Setup**

### Receive Only or Receive/Transmit Mode

Determine if “receive only” mode or “receive/transmit” mode is to be used and set the Mode Select switch SW4-2 as described in "Mode Select Switch - SW4" on page 16.

**Note:** Only one EIA-485 device per address may be set for receive/transmit.

## Setting the DIP Switches

The DIP switch (SW3), in combination with the Rotary Switches, is used to determine which FACP activations will trigger relays on the ACM-8RF.

As described previously, the selection of “Alarm Only” or “Alarm/Trouble” will determine how each module controls its relays. The difference between these two settings is described below.

### Alarm Only Activation

When “Alarm Only” is selected all relays respond to alarm signals.

The following table displays a dual example (zones & modules) of how to set the DIP switches on two (2) ACM-8RFs to annunciate the zones or points of an annunciator address. Although this table shows System Points & Zones 1 to 8 (address 01) and Loop 1, Points M65 to M80 (address 05), by referring to Table 13 on page 38 it can be determined which ACM-8RF will activate what zone or point, depending on the address that is set on the rotary switches.

	ACM-8RF Relay	MS-9600 Zone <sup>1</sup> or Point <sup>2</sup>	
<b>1st ACM-8RF</b> SW3-1 = ON SW3-5 = ON All others = OFF	Relay 1	System Alarm	or Loop 1, Address M65
	Relay 2	Not Used	or Loop 1, Address M66
	Relay 3	Not Used	or Loop 1, Address M67
	Relay 4	Not Used	or Loop 1, Address M68
	Relay 5	Not Used	or Loop 1, Address M69
	Relay 6	Not Used	or Loop 1, Address M70
	Relay 7	Not Used	or Loop 1, Address M71
	Relay 8	Not Used	or Loop 1, Address M72
<b>2nd ACM-8RF</b> SW3-2 = ON SW3-5 = ON All others = OFF	Relay 1	Zone 1	or Loop 1, Address M73
	Relay 2	Zone 2	or Loop 1, Address M74
	Relay 3	Zone 3	or Loop 1, Address M75
	Relay 4	Zone 4	or Loop 1, Address M76
	Relay 5	Zone 5	or Loop 1, Address M77
	Relay 6	Zone 6	or Loop 1, Address M78
	Relay 7	Zone 7	or Loop 1, Address M79
	Relay 8	Zone 8	or Loop 1, Address M80

1. As per Table 13 the Rotary Switches (SW1 & SW2) are set to address ‘01’ for System Points and Zones 1 to 56.
2. As per Table 13 the Rotary Switches (SW1 & SW2) are set to address ‘05’ for Loop 1, Address M65 to M128.

**Table 16 SW3 Settings for Alarm Only**

**Note:** If the System Points (system alarm) is not required, up to seven (7) ACM-8RFs may be used to allow activation of FACP zones 1 through 56. When using this configuration do not use the DIP Switch settings for the 1st ACM-8RF.



### Alarm and Trouble Activation

When “Alarm/Trouble” is selected, relays 1 - 4 respond to alarm signals and relays 5 - 8 respond to trouble signals.

The following table displays an example of how to set the DIP switches on four (4) ACM-8RFs to annunciate the zones of an annunciator address. Although this table shows System Points & Zones 1 to 8 (address 01), by referring to Table 13 on page 38 it can be determined which ACM-8RF will activate what zone or point, depending on the address that is set on the rotary switches.

	ACM-8RF Alarm Relay	MS-9600 Zone	ACM-8RF Trouble Relay	MS-9600 Zone
<b>1st ACM-8RF</b> SW3-1 = ON SW3-5 = ON All others = OFF	1=System Alarm	System Point	5=System Trouble	System Point
	2 (not used)	System Point	Relay 6 (not used)	System Point
	3 (not used)	System Point	7=System Off Normal	System Point
	4 (not used)	System Point	8=System Supervisory	System Point
<b>2nd ACM-8RF</b> SW3-2 = ON SW3-5 = ON All others = OFF	1 (not used)	System Point	5=NAC Fault	System Point
	2 (not used)	System Point	6=Walktest Start	System Point
	3 (not used)	System Point	7=Battery Fail	System Point
	4 (not used)	System Point	8=AC Fail	System Point
<b>3rd ACM-8RF</b> SW3-3 = ON SW3-5 = ON All others = OFF	Relay 1	Zone 1	Relay 5	Zone 1
	Relay 2	Zone 2	Relay 6	Zone 2
	Relay 3	Zone 3	Relay 7	Zone 3
	Relay 4	Zone 4	Relay 8	Zone 4
<b>4th ACM-8RF</b> SW3-4 = ON SW3-5 = ON All others = OFF	Relay 1	Zone 5	Relay 5	Zone 5
	Relay 2	Zone 6	Relay 6	Zone 6
	Relay 3	Zone 7	Relay 7	Zone 7
	Relay 4	Zone 8	Relay 8	Zone 8

**Table 17 SW3 Settings for Alarm/Trouble - Zones**

**Note:** If the System Points (system alarm, trouble or silence etc.) is not required, up to fourteen (14) ACM-8RFs may be used to allow activation of FACP zones 1 through 56. When using this configuration do not use the DIP Switch settings for the 1st ACM-8RF.

The following table displays an example of how to set the DIP switches on four (4) ACM-8RFs to annunciate the points of an annunciator address. Although this table shows Points M65 to M80 (address 05), by referring to Table 13 on page 38 it can be determined which ACM-8RF will activate what zone or point, depending on the address that is set on the rotary switches.

	ACM-8RF Alarm Relay	MS-9600 Point	ACM-8RF Trouble Relay	MS-9600 Point
<b>1st ACM-8RF</b> SW3-1 = ON SW3-5 = ON All others = OFF	Relay 1	Loop1-Address M65	Relay 5	Loop1-Address M65
	Relay 2	Loop1-Address M66	Relay 6	Loop1-Address M66
	Relay 3	Loop1-Address M67	Relay 7	Loop1-Address M67
	Relay 4	Loop1-Address M68	Relay 8	Loop1-Address M68
<b>2nd ACM-8RF</b> SW3-2 = ON SW3-5 = ON All others = OFF	Relay 1	Loop1-Address M69	Relay 5	Loop1-Address M69
	Relay 2	Loop1-Address M70	Relay 6	Loop1-Address M70
	Relay 3	Loop1-Address M71	Relay 7	Loop1-Address M71
	Relay 4	Loop1-Address M72	Relay 8	Loop1-Address M72
<b>3rd ACM-8RF</b> SW3-3 = ON SW3-5 = ON All others = OFF	Relay 1	Loop1-Address M73	Relay 5	Loop1-Address M73
	Relay 2	Loop1-Address M74	Relay 6	Loop1-Address M74
	Relay 3	Loop1-Address M75	Relay 7	Loop1-Address M75
	Relay 4	Loop1-Address M76	Relay 8	Loop1-Address M76
<b>4th ACM-8RF</b> SW3-4 = ON SW3-5 = ON All others = OFF	Relay 1	Loop1-Address M77	Relay 5	Loop1-Address M77
	Relay 2	Loop1-Address M78	Relay 6	Loop1-Address M78
	Relay 3	Loop1-Address M79	Relay 7	Loop1-Address M79
	Relay 4	Loop1-Address M80	Relay 8	Loop1-Address M80

**Table 18 SW3 Settings for Alarm/Trouble - Points**

### Multiple ACM-8RFs

The table below provides DIP switch (SW3) settings for the use of multiple ACM-8RFs. Only those switches listed in the ON column are placed in the 'ON' position. All other switches are to be in the 'Off' position.

	ON		ON
1st ACM-8RF	1 & 5	9th ACM-8RF	1 & 7
2nd ACM-8RF	2 & 5	10th ACM-8RF	2 & 7
3rd ACM-8RF	3 & 5	11th ACM-8RF	3 & 7
4th ACM-8RF	4 & 5	12th ACM-8RF	4 & 7
5th ACM-8RF	1 & 6	13th ACM-8RF	1 & 8
6th ACM-8RF	2 & 6	14th ACM-8RF	2 & 8
7th ACM-8RF	3 & 6	15th ACM-8RF	3 & 8
8th ACM-8RF	4 & 6	16th ACM-8RF	4 & 8

**Table 19 DIP Switch Settings for Multiple ACM-8RFs**

# Index

## Numerics

120 ohm ELR 14, 21, 31, 37  
 120 volts AC 13  
 24 VDC 8, 11, 19

## A

ABS-8RF 7, 11, 16  
 AC Fail 21, 31, 37  
 activations 22, 32, 37, 40  
 address 16, 40  
 Address Select Rotary Switches 32, 38  
 address setting 9  
 address switches 15  
 alarm 21  
 alarm activation 16  
 Alarm Pre-signal Sequence 31, 37  
 alarm signal 39, 40, 41  
 Alarm Silence 31, 37  
 Alarm Verification Retard 21, 31, 37  
 Alarm/Trouble activation 9  
 annunciator address 38, 40, 41, 42  
 autoresettable operation 21

## B

backbox 7, 16  
 Battery Trouble 21, 31, 37

## C

CAB-3F Series 7  
 cabinet 7, 13, 14  
 cable 13  
 chassis 7  
 CHS-4F chassis 7  
 CHS-4L chassis 7  
 circuit wiring 17  
 communication failure 11  
 compatible devices 8  
 conduit 13, 14, 17  
 contact ratings 19  
 contacts 8  
 Copper Wire 13

current draw 19

## D

daisy chain 8  
 Detector 38  
 DIP switch 9, 15, 22, 23, 32, 33, 40, 41, 42

## E

earth ground 11, 13, 14, 16  
 EIA-485 39  
 EIA-485 bus 9, 13, 16, 21, 31, 37  
 enclosure 11, 13, 14  
 external power supply 11

## F

faceplate 7, 16  
 FCPS-24F 8  
 Form-C contacts 12  
 Form-C relays 7, 8  
 function 9

## I

impedance 13

## K

knockout 11, 17

## L

LDM Series annunciators 7  
 LED annunciators 7  
 LED-10 27, 30  
 LED-10 Annunciators 26, 28  
 lightning protection 16  
 Loop 40

## M

mode of operation 9, 16  
 Mode Select Switch 16  
 Module 38  
 multiple ACM-8RFs 42

## Index

multiple modules 11  
multiple shields 13  
multiple wiring 14

## N

NAC Fault 21, 31, 37  
NEC Article 250 11  
no conduit 14  
nonpower-limited 17

## O

other devices 16

## P

point 39  
points 37, 40, 42  
power calculations 19  
power supply 11  
power supply requirements 19  
power-limited 9, 11, 13, 17, 19  
Power-limited label 17  
Pre-signal Sequence 21  
Process Monitoring 21  
protection 16

## R

Receive mode 16  
Receive/Transmit mode 9, 16  
regulated 11  
relay assignment 15  
relay triggering 22, 23, 32, 33  
relays 39, 40  
Reset 21  
Reset periods 31, 37  
resistance 11, 13  
resistor 14  
rotary switches 9, 32, 38, 40

## S

shield 13, 14  
special functions 7, 21, 37  
status functions 33  
supervised 11  
Supervisory 21, 31, 37  
supervisory data 16

SW1 9, 15, 32, 38  
SW2 9, 15, 32, 38  
SW3 9, 15, 22, 23, 32, 33, 40, 42  
SW4 9, 16, 22, 32, 39  
switch settings 15, 22  
system address 9  
System Alarm 31, 37  
system alarm 40  
system alarm, trouble or silence 41  
system common 13  
system function 9  
System Trouble 31, 37

## T

TB1 8, 11  
TB2 9, 14  
terminal assignments 12  
terminal blocks 8, 16  
tested 21, 31, 37  
transient protection 16  
trouble 21  
trouble activation 16  
trouble signal 39  
trouble signals 41  
T-tapped 13

## U

UDACT-F 7, 33, 35, 38

## W

Walktest 21, 31, 37  
wire-nut 13  
wiring diagram 17  
wiring distance 13

## Z

zone 7, 39  
zone function 9  
zones 21, 31, 37, 40, 41





## ***Limited Warranty***

The manufacturer warrants its products to be free from defects in materials and workmanship for eighteen (18) months from the date of manufacture, under normal use and service. Products are date-stamped at time of manufacture. The sole and exclusive obligation of the manufacturer is to repair or replace, at its option, free of charge for parts and labor, any part which is defective in materials or workmanship under normal use and service. For products not under the manufacturer's date-stamp control, the warranty is eighteen (18) months from date of original purchase by the manufacturer's distributor unless the installation instructions or catalog sets forth a shorter period, in which case the shorter period shall apply. This warranty is void if the product is altered, repaired, or serviced by anyone other than the manufacturer or its authorized distributors, or if there is a failure to maintain the products and systems in which they operate in a proper and workable manner. In case of defect, secure a Return Material Authorization form from our customer service department. Return product, transportation prepaid, to the manufacturer.

This writing constitutes the only warranty made by this manufacturer with respect to its products. The manufacturer does not represent that its products will prevent any loss by fire or otherwise, or that its products will in all cases provide the protection for which they are installed or intended. Buyer acknowledges that the manufacturer is not an insurer and assumes no risk for loss or damages or the cost of any inconvenience, transportation, damage, misuse, abuse, accident, or similar incident.

THE MANUFACTURER GIVES NO WARRANTY, EXPRESSED OR IMPLIED, OF MERCHANTABILITY, FITNESS FOR ANY PARTICULAR PURPOSE, OR OTHERWISE WHICH EXTEND BEYOND THE DESCRIPTION ON THE FACE HEREOF. UNDER NO CIRCUMSTANCES SHALL THE MANUFACTURER BE LIABLE FOR ANY LOSS OF OR DAMAGE TO PROPERTY, DIRECT, INCIDENTAL, OR CONSEQUENTIAL, ARISING OUT OF THE USE OF, OR INABILITY TO USE THE MANUFACTURER'S PRODUCTS. FURTHERMORE, THE MANUFACTURER SHALL NOT BE LIABLE FOR ANY PERSONAL INJURY OR DEATH WHICH MAY ARISE IN THE COURSE OF, OR AS A RESULT OF, PERSONAL, COMMERCIAL, OR INDUSTRIAL USE OF ITS PRODUCTS.

This warranty replaces all previous warranties and is the only warranty made by the manufacturer. No increase or alteration, written or verbal, of the obligation of this warranty is authorized.



World Headquarters

One Fire-Lite Place, Northford, CT 06472-1653 USA

203-484-7161 • Fax 203-484-7118

[www.firelite.com](http://www.firelite.com)

