

LIFE SAFETY & INCIDENT MANAGEMENT

Lightweight High Power Speaker Arrays

Hyperspike® Series



Overview

EDWARDS brand Hyperspike Series High Power Speaker Arrays (HPSA) employ exclusive HyperSpike® technology to deliver lightweight and acoustically sophisticated solutions for mass notification installations. These rugged outdoor-rated units are among the industry's smallest in physical size, yet they reproduce some of the clearest (up to 0.91 STI, source-dependant) and loudest (up to 126 dBA Fast @ 1m) audio signals available. Loudspeaker heads are as small as 13.2" (33.5 cm) in diameter and 24.7" (62.7 cm) in height. A single panel unit weighs as little as 16 lbs (7.3 kg).

Hyperspike Series loudspeakers are available in a number of different configurations, from one panel configurations that provide a relatively narrow sound dispersion, to five-panel configurations with full 360° sound projection.

The unique design of Hyperspike Series loudspeakers allow for a 100 percent up-time duty cycle—when powered from an AC source, they can be powered and ready to perform 24/7. This makes them ideally suited for daily activation, as well as emergency use.

Hyperspike Series HPSAs can be permanently installed, or can be configured for portable use. Units come standard with an internal inverter/charger system that can operate the HPSA from the 24 VDC battery compliment.

Each Hyperspike Series HPSA loudspeaker requires a separately-purchased remotely-mounted Electronics Control Cabinet (ECC) that can be installed indoors or outdoors. These house the audio power amplifiers as well as control and power equipment. The lockable reinforced fiberglass cabinets are rated NEMA 3, 3R, 3S, 4, 4X, 12, 12K and 13. They come ready to interface with the EST3 Emergency Communication Platform.

Standard Features

- Intelligible audio performance (up to 0.91 STI)
- 24/7/365 duty cycle
- 360, 230, 185 and 120 degree dispersion pattern options
- 320 to 6400 watt configurations
- Optional ethernet and wireless capability with additional equipment
- Easy installation—mounts to standard 2-inch diameter mast
- Lightweight loudspeaker heads—as low as 16 pounds (7.3 kg)
- Rugged outdoor construction
- Reliable and supervised interfaces to the EST3 Emergency Communications platform
- Includes an 8 ft (2.44 m) flexible weathertight wiring conduit
- Ethernet & Wireless capability (additional equipment required)

Application

Any outdoor facilities, such as:

- Universities, Colleges & High Schools
- Health care campuses
- Quads
- Parking lots
- Military bases
- Force protection
- Large ships
- Piers
- Docks
- Industrial complexes
- Refineries
- Power plants
- Air fields
- Stadiums
- Golf Courses
- Camp Grounds
- Amusement parks
- Open mines
- Weather warning systems
- Flood warning systems
- Civil defense

Installation

For optimal performance and safety when installing in permanent locations, High Power Speaker Arrays (HPSAs) loudspeakers should be mounted 35 to 55 feet (10.7 to 16.8 m) above grade on a pole, building or other structure. For portable or vehicle-mounted applications, the loudspeaker head should be at least 20 feet (6.1 m) above grade and away from people. For all installations, it is also key to have clear, open space around the speaker head. HPSA output is best via line-of-sight.

The factory assembled and tested Electronics Control Cabinets (ECCs) contain the HPSA interface terminals, transient protectors, and components to support easy, clean, and supervised connection to the EST3 Emergency Communications platform. This makes for simple and intuitive control of the units from a single control point or multiple locations.

The ECCs contain the power amplifier(s), digital signal processor, and power inverter system. Batteries are maintained in a Ready State by a temperature-compensated charging system.

The ECCs can be mounted inside or outside. Mounting options include pole, flange (wall), or pedestal. Heaters and ventilation units can also be ordered when required. When outdoor mounting, ECC and battery cabinets can be mounted below the loudspeaker head for easy access, but high enough to prevent vandalism. The ECC can hold one or two replaceable power amplifiers. Cabinets are equipped with tamper switches.

Internal displays and diagnostic LEDs simplify maintenance. HPSA status is also transmitted to the EST3 Emergency Communications platform. A GFCI-protected convenience outlet is provided with ECCs to aid in servicing. All ECC power is protected with circuit breakers. Exterior wiring to and from the ECC is protected by transient protectors.

Typically, the Hyperspike Series HPSA provides the EST3 Emergency Communications platform with the following signals:

- Activation Confirmation
- Incoming AC failure
- Inverter AC failure
- Audio failure
- DC failure
- Door tamper

Units come standard with a one year warranty. An optional second year of additional coverage may be purchased at the time of the initial order. Warranties exclude batteries, which carry a 90-day warranty.

US Military Specifications

Loudspeaker Head

Hot Temperature	MIL-STD-810G Method 501.5 Procedure II (60C)
Cold Temperature	MIL-STD-810G Method 501.5 Procedure II (-20C)
Blowing Rain	MIL-STD-810G Method 506.5 Procedure I
Aggravated Humidity	MIL-STD-810G Method 507.5 Procedure II
Salt Fog	MIL-STD-810G Method 509.5
Blowing Dust	MIL-STD-810G Method 510.5 Procedure I

Typical Deployment

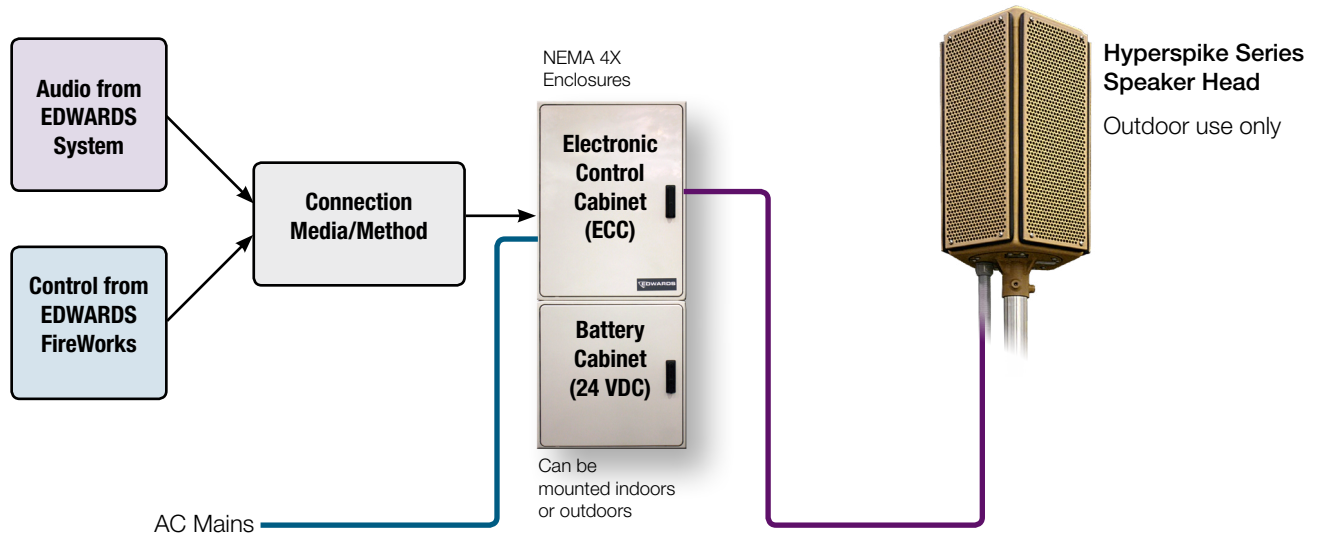

Specifications

Loudspeakers

	Speaker Panels	Sound Dispersion	1600 Class	3200 Class	6400 Class
Output	5 Panel Array	360°	1600 Watts	3200 Watts	6400 Watts
	3 Panel Array	230°	960 Watts	1920 Watts	3840 Watts
	2 Panel Array	185°	640 Watts	1280 Watts	2560 Watts
	1 Panel Array	120°	320 Watts	640 Watts	1280 Watts
Weight	5 Panel Array	360°	48 lb. (21.77 kg)	96 lb (43.55 kg)	192 lb (87.09 kg)
	3 Panel Array	230°	31 lb (14.06 kg)	62 lb (28.12 kg)	124 lb (56.25 kg)
	2 Panel Array	185°	24 lb (10.89 kg)	48 lb (21.77 kg)	96 lb (43.55 kg)
	1 Panel Array	120°	16 lb (7.26 kg)	32 lb (14.52 kg)	64 lb (29.03 kg)
Dimensions	Each	Diameter	13.2" (33.52 cm)	13.2" (33.52 cm)	13.2" (33.52 cm)
	Each	Height	24.7" (62.7 cm)	44" (111.8 cm)	88" (223.5 cm)

Speaker Head: Outdoor operating temperature: -40F to 140F (-40C to +60C).

ECC (without heating/cooling system): -4F to 140F (-20C to +60C)

Indoor operating temperature: +32 °F to +120 °F (0 °C to 49 °C); Humidity: 0% to 95% (non-condensing)

Environmental

Electronics Control Cabinet

Dimensions	70" x 30" x 12"	70" x 30" x 12"	70" x 60" x 12"
	177.8 x 76.2 x 30.5 cm	177.8 x 76.2 x 30.5 cm	177.8 x 152.4 x 30.5 cm
Weight (without batteries)	242 lb (109.8 kg)	248 lb (112.5 kg)	496 lb (225.0 kg)

Sound Dispersion Patterns

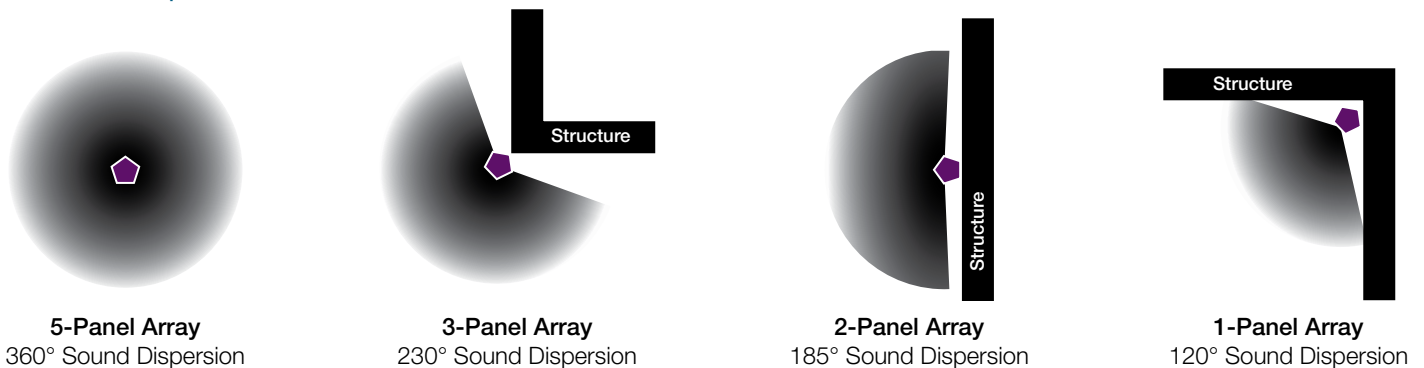

Ordering Information

High Power Speaker Arrays and Assemblies

HPSA Assemblies are AC powered with optional DC backup. They come with a lockable NEMA 4 Electronics Control Cabinet (ECC) that holds the amplifier and 110V/60Hz battery charger. Charger or loudspeakers and ECCs may also be ordered separately. Batteries and battery enclosures are ordered separately. Enclosures are equipped with tamper switches. Loudspeakers come pre-assembled with an eight foot (2.4 meter) ¾-inch liquid-tight flexible conduit whip and wire leads.

	Loudspeaker Assembly with ECC	Loudspeaker Only (order ECC separately)	Output	Sound Dispersion	Active Panels	Speaker Head Color
1600 Watt Class	MN-HS16T5P	MN-HSHT16P5N	1600 Watts	360°	5 of 5	Tan
	MN-HS16T3P	MN-HSHT16P3N	960 Watts	230°	3 of 5	
	MN-HS16T2P	MN-HSHT16P2N	640 Watts	185°	2 of 5	
	MN-HS16T1P	MN-HSHT16P1N	320 Watts	120°	1 of 5	
	Gray	MN-HS16G5P	MN-HSHG16P5N	1600 Watts	360°	5 of 5
		MN-HS16G3P	MN-HSHG16P3N	960 Watts	230°	3 of 5
		MN-HS16G2P	MN-HSHG16P2N	640 Watts	185°	2 of 5
		MN-HS16G1P	MN-HSHG16P1N	320 Watts	120°	1 of 5
3200 Watt Class	MN-HS32T5P	MN-HSHT32P5N	3200 Watts	360°	5 of 5	Tan
	MN-HS32T3P	MN-HSHT32P3N	1920 Watts	230°	3 of 5	
	MN-HS32T2P	MN-HSHT32P2N	1280 Watts	185°	2 of 5	
	MN-HS32T1P	MN-HSHT32P1N	640 Watts	120°	1 of 5	
	Gray	MN-HS32G5P	MN-HSHG32P5N	3200 Watts	360°	5 of 5
		MN-HS32G3P	MN-HSHG32P3N	1920 Watts	230°	3 of 5
		MN-HS32G2P	MN-HSHG32P2N	1280 Watts	185°	2 of 5
		MN-HS32G1P	MN-HSHG32P1N	640 Watts	120°	1 of 5
6400 Watt Class	MN-HS64T5P	MN-HSHT64P5N	6400 Watts	360°	5 of 5	Tan
	MN-HS64T3P	MN-HSHT64P3N	3840 Watts	230°	3 of 5	
	MN-HS64T2P	MN-HSHT64P2N	1280 Watts	185°	2 of 5	
	MN-HS64T1P	MN-HSHT64P1N	640 Watts	120°	1 of 5	
	Gray	MN-HS64G5P	MN-HSHG64P5N	6400 Watts	360°	5 of 5
		MN-HS64G3P	MN-HSHG64P3N	3840 Watts	230°	3 of 5
		MN-HS64G2P	MN-HSHG64P2N	2560 Watts	185°	2 of 5
		MN-HS64G1P	MN-HSHG64P1N	1280 Watts	120°	1 of 5

NEMA 4 Electronics Control Cabinets (ECCs)

ECCs hold the amplifier and 110V/60Hz battery charger. Enclosures are lockable and equipped with tamper switches. Loudspeakers, batteries, and battery enclosures are ordered separately.

NEMA 4 Electronics Control Cabinets (ECCs), loudspeakers ordered separately		Ethernet Capable	Battery Back up
MN-HSEC1-DH	MN-HS16 Class lockable NEMA 4 Electronic Control Cabinet (ECC) with amplifier, 110V/60Hz. inverter/battery charger (w/o batteries). Enclosure equipped with tamper switches. AC powered amplifier with DC backup. Batteries and accessories are ordered separately.	No	Yes
MN-HSEC1-DE	MN-HS16 Class lockable NEMA 4 Electronic Control Cabinet (ECC) with Ethernet capability, amplifier, 110V/60Hz. inverter/battery charger (w/o batteries). Enclosure equipped with tamper switches. AC powered amplifier with DC backup. Batteries and accessories are ordered separately.	Yes	Yes
MN-HSEC1-AH	MN-HS16 Class lockable NEMA 4 Electronic Control Cabinet (ECC) with amplifier, 110V/60Hz. inverter/battery charger (w/o batteries). Enclosure equipped with tamper switches. AC powered amplifier - NO BATTERY BACKUP. Accessories are ordered separately.	No	No
MN-HSEC1-AE	MN-HS16 Class lockable NEMA 4 Electronic Control Cabinet (ECC) with Ethernet capability, amplifier, 110V/60Hz. inverter/battery charger (w/o batteries). Enclosure equipped with tamper switches. AC powered amplifier - NO BATTERY BACKUP. Accessories are ordered separately.	Yes	No

NEMA 4 Electronics Control Cabinets (ECCs), loudspeakers ordered separately		Ethernet Capable	Battery Back up
MN-HSEC1-SH	MN-HS16 Class lockable NEMA 4 Electronic Control Cabinet (ECC) with amplifier, 230V/50Hz. inverter/battery charger (w/o batteries). Enclosure equipped with tamper switches. AC powered amplifier with DC battery back up. Accessories are ordered separately.	No	Yes
MN-HSEC1-SE	MN-HS16 Class lockable NEMA 4 Electronic Control Cabinet (ECC) with Ethernet capability, amplifier, 230V/50Hz. inverter/battery charger (w/o batteries). Enclosure equipped with tamper switches. AC powered amplifier with DC battery back up. Accessories are ordered separately.	Yes	Yes
MN-HSEC2-DH	MN-HS32 Class lockable NEMA 4 Electronic Control Cabinet (ECC) with amplifier, 110V/60Hz. inverter/battery charger (w/o batteries). Enclosure equipped with tamper switches. AC powered amplifier with DC battery backup. Batteries and accessories are ordered separately.	No	Yes
MN-HSEC2-DE	MN-HS32 Class lockable NEMA 4 Electronic Control Cabinet (ECC) with Ethernet capability, amplifier, 110V/60Hz. inverter/battery charger (w/o batteries). Enclosure equipped with tamper switches. AC powered amplifier with DC battery backup. Batteries and accessories are ordered separately.	Yes	Yes
MN-HSEC2-AH	MN-HS32 Class lockable NEMA 4 Electronic Control Cabinet (ECC) with amplifier, 110V/60Hz. inverter/battery charger (w/o batteries). Enclosure equipped with tamper switches. AC powered amplifier - NO BATTERY BACKUP. Accessories are ordered separately.	No	No
MN-HSEC2-AE	MN-HS32 Class lockable NEMA 4 Electronic Control Cabinet (ECC) with Ethernet capability, amplifier, 110V/60Hz. inverter/battery charger (w/o batteries). Enclosure equipped with tamper switches. AC powered amplifier - NO BATTERY BACKUP. Accessories are ordered separately.	Yes	No
MN-HSEC2-SH	MN-HS32 Class lockable NEMA 4 Electronic Control Cabinet (ECC) with amplifier, 230V/50Hz. inverter/battery charger (w/o batteries). Enclosure equipped with tamper switches. AC powered amplifier with DC battery backup. Accessories are ordered separately.	No	Yes
MN-HSEC2-SE	MN-HS32 Class lockable NEMA 4 Electronic Control Cabinet (ECC) with Ethernet capability, amplifier, 230V/50Hz. inverter/battery charger (w/o batteries). Enclosure equipped with tamper switches. AC powered amplifier with DC battery backup. Accessories are ordered separately.	Yes	Yes
MN-HSEC4-DH	MN-HS64 Class lockable NEMA 4 Electronic Control Cabinet (ECC) with amplifier, 110V/60Hz. inverter/battery charger (w/o batteries). Enclosure equipped with tamper switches. AC powered amplifier with DC backup. Batteries and accessories are ordered separately.	No	Yes
MN-HSEC4-DE	MN-HS64 Class lockable NEMA 4 Electronic Control Cabinet (ECC) with Ethernet capability, amplifier, 110V/60Hz. inverter/battery charger (w/o batteries). Enclosure equipped with tamper switches. AC powered amplifier with DC battery backup. Batteries and accessories are ordered separately.	Yes	Yes
MN-HSEC4-AH	MN-HS64 Class lockable NEMA 4 Electronic Control Cabinet (ECC) with amplifier, 110V/60Hz. inverter/battery charger (w/o batteries). Enclosure equipped with tamper switches. AC powered amplifier - NO BATTERY BACKUP. Accessories are ordered separately.	No	No
MN-HSEC4-AE	MN-HS64 Class lockable NEMA 4 Electronic Control Cabinet (ECC) with Ethernet capability, amplifier, 110V/60Hz. inverter/battery charger (w/o batteries). Enclosure equipped with tamper switches. AC powered amplifier - NO BATTERY BACKUP. Accessories are ordered separately.	Yes	No
MN-HSEC4-SH	MN-HS64 Class lockable NEMA 4 Electronic Control Cabinet (ECC) with amplifier, 230V/50Hz. inverter/battery charger (w/o batteries). Enclosure equipped with tamper switches. AC powered amplifier with DC battery backup. Accessories are ordered separately.	No	Yes
MN-HSEC4-SE	MN-HS64 Class lockable NEMA 4 Electronic Control Cabinet (ECC) with Ethernet capability, amplifier, 230V/50Hz. inverter/battery charger (w/o batteries). Enclosure equipped with tamper switches. AC powered amplifier with DC battery backup. Accessories are ordered separately.	Yes	Yes

Accessories

Protective Covers

MN-HS16GPC	Gray Hyperspike Series 1600 Watt class optional protective cover.
MN-HS32GPC	Gray Hyperspike Series 3200 Watt class optional protective cover
MN-HS64GPC	Gray Hyperspike Series 6400 Watt class optional protective cover
MN-HS16TPC	Tan Hyperspike Series 1600 Watt class optional protective cover.
MN-HS32TPC	Tan Hyperspike Series 3200 Watt class optional protective cover
MN-HS64TPC	Tan Hyperspike Series 6400 Watt class optional protective cover

Ethernet

MN-POE60WT	High Power PoE+(power over ethernet) injector, Max output of 60W at 24/48VDC, -40 to 75 °C operating temperature.
------------	---

Warranty Programs

MN-HS16EXWARR2	Hyperspike Series 1600 Watt class extended warranty - 2 years total. Must be ordered when HPSA is ordered.
MN-HS32EXWARR2	Hyperspike Series 3200 Watt class extended warranty - 2 years total. Must be ordered when HPSA is ordered.
MN-HS64EXWARR2	Hyperspike Series 6400 Watt class extended warranty - 2 years total. Must be ordered when HPSA is ordered.

Batteries and Accessories

MN-HSBHK1X	Hyperspike Series Battery compliment heating blankets (set of 2) for use with MN-HSBX1 Extended Battery Enclosure. 120 VAC. Requires MN-HSECCH1.
MN-HSBHK1S	Hyperspike Series Battery compliment heating blankets (set of 2). 120 VAC. Requires MN-HSECCH1. Two used for MN-HS64 Series.
MN-HSBX1	Hyperspike Series ECC Battery Extension enclosure (without batteries). Includes tamper switch, battery shelf and cabling. Can be mounted to the side or below the ECC primary battery enclosure.

Heating and Ventilation

MN-HSECCFAN1	Hyperspike Series ECC Top-mount ventilation fan system with side louvers. 115 VAC. Changes ECC rating to NEMA 3R
MN-HSECCH1	Hyperspike Series ECC Cabinet heater system kit (120 VAC). Provides terminals for battery heater blanket kits. One used for MN-HS16 & MN-HS32 Series. Two used for MN-HS64 Series.

Demo, Portable & Specialty

MN-HS16DFDEMO1	Gray Hyperspike Series demo unit, 1600 watt with 120 VAC amplifier, microphone, MP3 player. Order tripods & accessories separately.
MN-HS16DFPORT1	Gray Hyperspike Series portable 1600 watt 120 VAC system, with 120 VAC amplifier, laptop computer & case, microphone & software. Order tripods and accessories separately.
MN-HS16G5PAC	EDWARDS System-based 1600 Watt Omni-directional HPSA Assembly (5 of 5 Active Panels) with lockable NEMA 4 amplifier and electronics enclosure. 110V/60Hz operation only. Enclosure equipped with tamper switch. EDWARDS hard-wire interface included. Accessories are ordered separately. Gray colored speaker head.
MN-HS32DFDEMO1	Gray Hyperspike Series demo unit, 3200 watt with 120 VAC amplifier, microphone, MP3 player. Order tripods & accessories separately.
MN-HS32G5PAC	EDWARDS System-based 3200 Watt Omni-directional HPSA Assembly (5 of 5 Active Panels) with lockable NEMA 4 amplifier and electronics enclosure. 110V/60Hz operation only. Enclosure equipped with tamper switch. EDWARDS hard-wire interface included. Accessories are ordered separately. Gray colored speaker head.

Audio Software

MN-AUDSOF1	Hyperspike Series audio optimization software package
------------	---

Modeling Services

MN-HSEMD12	Hyperspike Series EASE modeling exterior direct/reflected energy. Up to (12) 3D buildings overlaid on Google earth map or provided PDF/CAD site topology drawing. Modeling based on 125-2Khz band and provide medium resolution graphics with 3dB steps in propagation for up to (6) acoustic device/array locations onto chloropleth map. Scale limit of this offer is for 4 million square feet venue.
MN-HSEMDNB	Hyperspike Series EASE modeling exterior direct energy only (no 3D buildings) overlaid on Google earth map or on provided PDF/CAD site topology drawing. Modeling based on 125-2Khz band and provide medium resolution graphics with 3dB steps in propagation for up to (4) acoustic device/array locations onto chloropleth map. Scale limit of this service is in 2 million square feet increments.
MNHSEMDQ	Hyperspike Series Ease modeling exterior direct/reflected energy. Over 12 3D buildings overlaid on Google earth map or provided PDF/CAD site topology drawing. Modeling based on 125-2Khz band and provide medium resolution graphics with 3dB steps in propagation for system required acoustic device/array locations onto chloropleth map. Contact EDWARDS Customer Service for quote.
MN-HSEMN12	Hyperspike Series EASE modeling interior direct/reflected energy. Up to (12) interior 3D substructures overlaid on provided PDF/CAD plan view drawing. Modeling based on 125-2Khz band and provide medium resolution graphics with 3dB steps in propagation for up to (10) acoustic device/array locations onto chloropleth map. Scale limit of this offer is for 250,000 square foot venue.
MN-HSEMN24	Hyperspike Series EASE modeling interior direct/reflected energy. Up to (24) interior 3D substructures overlaid on provided PDF/CAD plan view drawing. Modeling based on 125-2Khz band and provide medium resolution graphics with 3dB steps in propagation for up to (16) acoustic device/array locations onto chloropleth map. Scale limit of this offer is for 500,000 square foot venue.
MN-HSEMNQ	Hyperspike Series EASE modeling interior direct/reflected energy. Over 24 interior 3D substructures overlaid on provided PDF/CAD plan view drawing. Modeling based on 125-2Khz band and provide medium resolution graphics with 3dB steps in propagation for up to system required acoustic device/array locations onto chloropleth map. Contact EDWARDS customer service for quote.

Mounting Accessories

MN-HSECCPM1	Hyperspike Series ECC pole-mount installation kit. For use with MN-HS16 & MN-HS32 Series only.
MN-HSLPMK1	Hyperspike Series Emitter (loudspeaker) pole-mount kit. Bolts to steel or wooden pole. Additional support may be necessary.
MN-HSPM16	Portable Hyperspike Series HPSA portable tripod mast. Extends up to 16'
MN-HSPM33	Hyperspike Series Portable mast & guy wire unit. Extends up to a maximum 33' (10M)
MN-HSTPMS1	Hyperspike Series Emitter (loudspeaker) tripod mounting system. 10' tripod with 14' mast. Additional support and guy wires may be necessary. ECC cannot be mounted to this unit.
MN-HSWB1	Hyperspike Series Emitter head (loudspeaker) wall-mount bracket & installation kit
MN-HSECCPED1	Hyperspike Series ECC Housekeeping Pedestal Mount Kit (4"). Used when wall-mounting MN-HS16 or MN-HS32 Series ECC. 2 required if wall-mounting MN-HS64 Series ECCs.
MN-HSTEP1	Heavy duty foldable tripod with 3ft extension and carrying bag. Suggested use with 1600 watt HPSA or 650 watt MPSA demonstration kits. Not to be used with 3200 watt or 6400 watt systems.
MN-HSMPWMB1	HS Series MN-HSMP200 Class emitter wall mount.
MN-HSMPCMB1	HS Series MN-HSMP200 or MN-HSMP300 Class emitter head ceiling mount.
MN-HSECCHDWB1	HS Series Heavy Duty ECC Wall Mount kit. To be used when the ECC is being mounted to a wall without a pedestal to support the ECC.
MN-HSECMBRK1	HS Series MN-MP650 or MN-HS16 Class Emitter head ceiling mount.
MN-HSE5SBRK1	HS Series MN-HS16 Class Emitter wall mount for five active side appliances.

Power Amplifiers & Components

MN-HSAMPCL16	Hyperspike ECC replacement 120 VAC power amplifier and mated compressor/limiter mounted in mini-rack for ECC for MN-HS16 Series
MN-HSAMPCL32	Hyperspike Series ECC replacement 120 VAC power amplifier and mated compressor/limiter mounted in mini-rack for ECC for MN-HS32 Series (1 used) or MN-HS64 Series (2 used)
MN-HSECCACB20	Hyperspike Series ECC Replacement AC Circuit breaker - 20 Amp
MN-HSECCACB30	Hyperspike Series ECC Replacement AC Circuit breaker - 30 Amp
MN-HSECCDM1	Hyperspike Series ECC Replacement inverter display module
MN-HSPAXFM1	Hyperspike ECC Replacement pre-amp audio isolation transformer module
MN-HSPWR110	Hyperspike Replacement 24VDC/120VAC charger/inverter module
MN-HSECCDCB1	Hyperspike ECC replacement DC Circuit breaker with mounting hardware
MN-TP1201P	TP Series 120V AC line transient protector module
MN-TP120STD	TP Series 120V circuit transient protector module
MN-TP24STD	TP Series 24V circuit transient protector module
MN-TP90STD	TP Series 90V circuit transient protector module
MN-TPBLK1	TP Series Single circuit breaker lockout kit
MN-TPRJ31STD	TP Series RJ31 transient protector module
MN-TPRJ45STD	TP Series RJ45 transient protector module
MN-VR241	Hyperspike Series DC Sensitive Supervision Relay
MN-HSSPKR1	Hyperspike Series replacement loudspeaker panel (3 speakers per panel)

Doors and Mounting Hardware

MN-HSECCDPK1	Hyperspike Series ECC Door replacement pin and E-clip kit (8 pins and 8 clips)
MN-HSECCLD	Hyperspike Series ECC Replacement lower door. One used for MN-HS16 & MN-HS32 Series. Two used for MN-HS64 Series.
MN-HSECCUD	Hyperspike Series ECC Replacement upper door. One used for MN-HS16 & MN-HS32 Series. Two used for MN-HS64 Series.
MN-HSRPLKEY1	Hyperspike Series replacement key set (2 keys)



LIFE SAFETY & INCIDENT MANAGEMENT

Contact us

Phone: 800-655-4497 (Option 4)

Email: edwards.fire@carrier.com

Website: edwardsfiresafety.com

8985 Town Center Pkwy
Bradenton, FL 34202

© 2020 Carrier
All rights reserved.
