

LIFE SAFETY &amp; INCIDENT MANAGEMENT

# Centralized Banked Amplifiers

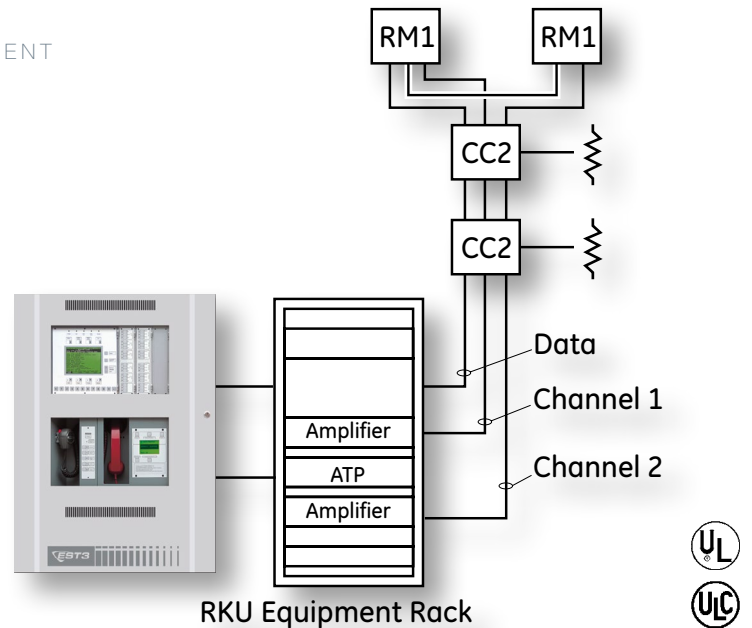

## Overview

EST3 supports centralized (banked) amplifier configurations for Mass Notification/Emergency Communication (MNEC), life safety, and emergency signaling.

Model 3-ZA20 Zoned Amplifiers at the EST3 control panel provide a channel source(s) for banked amplifiers. The 3-ZA20 amplifiers can select any one (at a time) of the EST3 eight audio channels as a signal source. Examples include; page, alert and evacuation. Standby Amplifier(s) are an option.

Special interface modules, the 3-ATPINT, or MN-ABPM panel-mount, accept analog audio signals @ 25 or 70 Vrms from EST3's zoned amplifiers and passes these signals to the 1B3-125 and 1B3-250 audio power amplifiers via an Amplifier Terminal Panel (ATP). The 3-ATPINT can pass supervised audio signals to other ATPINTs within a local amplifier bank or to other remote banks of amplifiers. The 3-ATPINT mounts on the ATP.

The ATP Audio Terminal Panel interfaces one or two audio power amplifiers and monitors utility power, charges and supervises standby batteries, and provides switch-over to standby. Audio risers connect at this panel. It also has an integral trouble signal and silence switch.

The EST3 System monitors and controls the amplifier bank through Signature series modules such as the SIGA-CT1 or 2 input modules and the SIGA-CR control relay. MR-201/C or MN-204/C relays provide DPDT contacts for switching power amplifier risers when a system has standby amplifiers.

SIGA-CC1 (Single Channel) or CC2 (Dual Channel) output control modules command and supervise each audio circuit or zone. The SIGA-RM1 Riser Monitor Module provides audio riser supervision.

## Standard Features

- Large Supervised Amplifiers [1B3-250 & 1B3-125]**
  - 250 or 125 Watt amplifiers
  - broad frequency response and low distortion
  - thermal and electronic protection
- Amplifier Terminal Panel [ATP]**
  - supports two audio power amplifiers
  - charges and supervises up to 40 AH batteries
  - standard 19 inch rack mounting
  - Terminal Panel Interface Module [3-ATPINT]
  - supports connection to EST3 Zoned Amplifiers
- Supported by System Definition Utility**
  - fast rules based programming
- Part of an end-to-end 520 Hz signaling solution**
  - UL approved for use in sleeping rooms
- Uses the 3-ASU & 3-ASU/FT Audio Source Units**
  - site-recordable or downloadable messages
  - live paging
  - hierarchical operation of eight distinct digital audio channels
- Uses the ZA20 amplifier as a source**
  - Class A or B connection
  - Supports Multiple PreAmps
  - Optional Standby PreAmps
  - 25 Vrms or 70 Vrms interface
  - drives multiple 3-ATPINTs in same rack



LIFE SAFETY & INCIDENT MANAGEMENT

**Contact us**

Phone: 800-655-4497 (Option 4)  
 Email: [edwards.fire@carrier.com](mailto:edwards.fire@carrier.com)  
 Website: [edwardsfiresafety.com](http://edwardsfiresafety.com)

8985 Town Center Pkwy  
 Bradenton, FL 34202

© 2020 Carrier  
 All rights reserved.

## Application

Life Safety Audio provides Emergency Response Personnel with a means to control building evacuation using voice instructions.

Banked Amplifiers provide EST3 with economy audio configurations for Single and some Dual channel applications.

## Typical Configuration

Block Wiring Layout

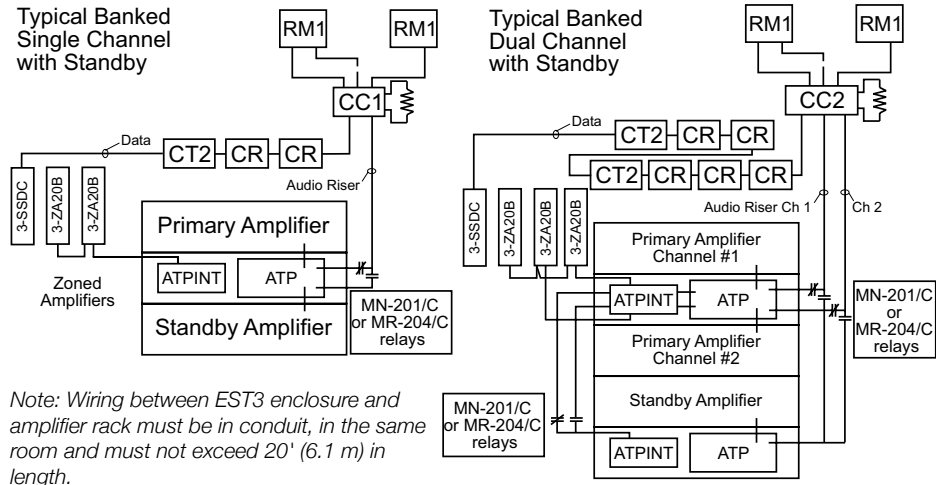

*Note: Wiring between EST3 enclosure and amplifier rack must be in conduit, in the same room and must not exceed 20' (6.1 m) in length.*

## Typical System Components

Data Sheets are available for the following components.

- 3-ASU/FT Audio Source Unit with Fire Phone
- 3-ASU Audio Source Unit
- 3-ATPINT Audio Terminal Panel Interface
- ATP Audio Terminal Panel
- ATP-220 Audio Terminal Panel 220 Vac
- 1B3-250 250 Watt Power Amplifier
- 1B3-125 125 Watt Power Amplifier
- SIGA-CT1 Single Circuit Input Module
- SIGA-CT2 Dual Circuit Input Module
- SIGA-RM1 Riser Monitor Module
- SIGA-CR Control Relay
- SIGA-MP1 Module Mounting Plate, eight spaces
- SIGA-MP2 Module Mounting Plate, four spaces
- ARM-8 Relay Module /w one relay, space for eight total
- MR-201/C Relay for ARM-8 (single DPDT)
- MR-204/C Relay for ARM-8 (four-position DPDT)
- RKU-42 Standard 19 inch Rack Mounting Cabinet, 42 inch
- RKU-61 Standard 19 inch Rack Mounting Cabinet, 61.25 inch
- RKU-70 Standard 19 inch Rack Mounting Cabinet, 70 inch
- RKU-77 Standard 19 inch Rack Mounting Cabinet, 77 inch
- VP-1 Vented Panel, 1.75 inch
- VP-3 Vented Panel, 3.5 inch
- BP-1 Blank Panel, 1.75 inch
- BP-2 Blank Panel, 3.5 inch
- BP-3 Blank Panel, 5.25 inch
- MFC Module Fire Cabinet

### Low Frequency Audio Signaling in Sleeping Rooms

EST3 Centralized Banked Amplifiers are part of an end-to-end low frequency solution listed to UL 464 and UL 864. It is approved for code-compliant 520 Hz signaling in sleeping areas when used in conjunction with:

- an EST3 control panel
- a factory-supplied 520 Hz audio file
- one or more of the following amplifiers: 3-ZA20A, 3-ZA20B, 3-ZA40A, 3-ZA40B, 3-ZA95, SIGA-AA30, SIGA-AA50, 1B3-125, or 1B3-250
- one or more Genesis High Fidelity speakers (G4HF or GCHF series)

Consult the EST3 System Compatibility List for details.