



1 000-020

Fireray® 50/100RU
Protective Wire Cage



Mounted on a 0608 Surface Mount Back Box

Installation

Important: Do not attempt to install the Protective Wire Cage until the reflective beam smoke detector has been correctly aligned according to the beam smoke detector instructions.

1. Center the Protective Wire Cage over existing unit, making sure the cutout in the cage is positioned over the beam lens. Use caution not to hit or bump the detector.
2. Position one clamp, mark, drill and install one clamp first, then complete installation of the remaining clamps.
3. The cage can be mounted to either a flat wall or rigid surface or the 0608 Surface Mount Back Box.



FFE Ltd
1455 Jamike Ave Ste 200, Erlanger
KY 41018-3147 USA

t 940 271 0435
f 972 534 1526
e america@ffeuk.com
w www.ffeuk.com

Formerly known as Fire Fighting Enterprises Ltd

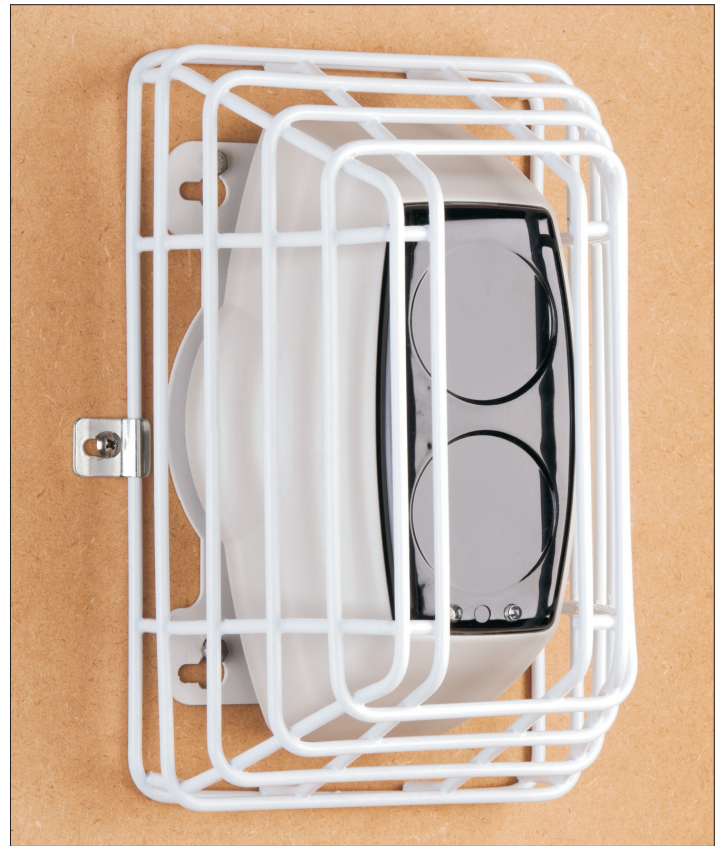

Specification

■ Weight: 1.1 lb.

Dimensions (in)

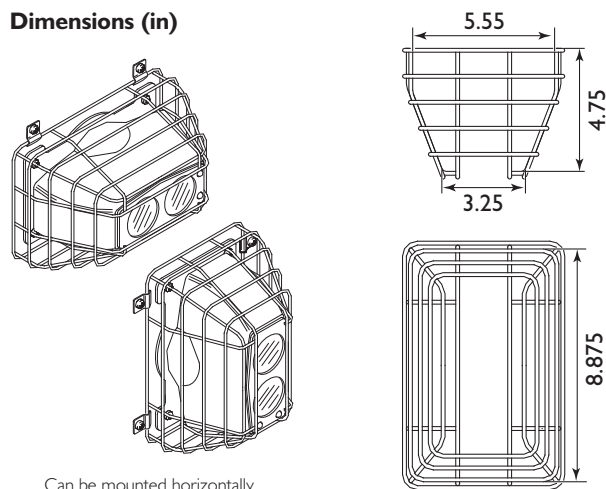

Specifications and wiring information are provided for information only and are believed to be accurate. FFE Ltd assumes no responsibility for their use. Data and design are subject to change without notice. Installation and wiring instructions are shipped with the products and should always be used for actual installation. For more information, contact your Sales Representative.

Document Part No: 24-0035-03