

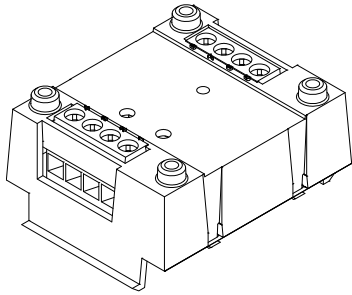

SIGA-CRR Polarity Reversal Relay Module Installation Sheet



Description

The SIGA-CRR Polarity Reversal Relay Module is an addressable device that is used to power and activate the audible sounder in Signature audible detector bases.

The module can support a 2 A load of bases. Upon command from the loop controller, the SIGA-CRR module relay transfers, reversing the polarity of its 24 VDC output.

The module requires one address on the signaling line circuit (SLC). Addresses are assigned electronically. There are no address switches.

Diagnostic LEDs provide visible indication of the state of the module through the cover plate:

- Normal: Green LED flashes
- Alarm/active: Red LED flashes

Personality code

The module requires the loop controller to download the personality code that determines how the module operates. Use the personality codes described below to configure the SIGA-CRR. See Table 1 for listing information.

Personality code 8: Signal - dry contact output. Configures the module as a dry relay contact to control external appliances (door closers, fans, dampers) or equipment shutdown.

Table 1: Personality code listing information

Code	Description	UL 864	CAN/ULC-S527	EN 54-18
8	Signal - dry contact output	Yes	Yes	Yes

Installation

Notes

- The module is shipped from the factory as an assembled unit; it contains no user-serviceable parts and should not be disassembled.
- This module does not operate without electrical power. As fires frequently cause power interruption, discuss further safeguards with the local fire protection specialist.

Install in accordance with all applicable local codes and standards and the local authority having jurisdiction.

To install the module:

1. Wire in accordance with "Wiring" on page 2.
2. Write the address assigned to the module on the label provided, and then apply the label to the module. Remove the serial number label from the module, and then attach it to the project documentation.
3. Using the screw provided, mount the wall plate on the module. See Figure 1 for mounting details.
4. Using the screws provided, mount the wall plate (with the module attached) on one of the compatible electrical boxes listed in "Specifications" on page 3.

Figure 1: Mounting the CRR module

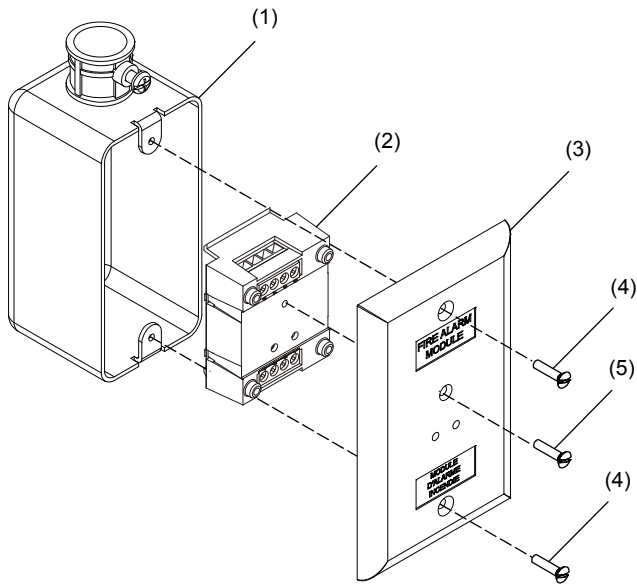

- | | |
|-------------------------------------|---------------------------------|
| (1) Compatible electrical box | (4) #6-32 x 5/8 machine screw |
| (2) Module | (5) #4 x 1/2 self-tapping screw |
| (3) Wall plate, white (single-gang) | |

Wiring

Wire in accordance with applicable requirements of the latest editions of the local codes and standards and the local authority having jurisdiction.

Note: When stripping wire ends, exposing more wire may cause a ground fault or circuit malfunction on unsupervised wiring; exposing less wire may result in a faulty connection.

Strip 1/4 in. (about 6 mm) from the ends of all wires that connect to the terminal block of the module.

Notes

- Refer to the Signature loop controller installation sheet for SLC wiring specifications.
- Each terminal on the module is limited to a single conductor.

To wire the module:

- Verify that all field wiring is free of opens, shorts, and ground faults.
- Make all wiring connections as shown in Figure 2.

Figure 2: Wiring diagram

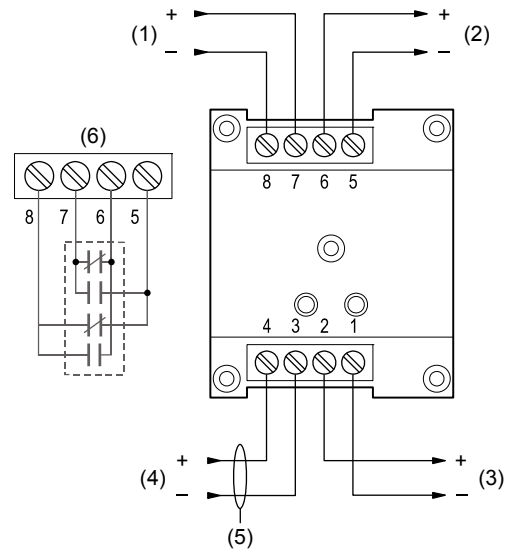

- Auxiliary riser in (from power-limited, regulated power supply listed for fire protective signaling)
- Auxiliary riser out (to next sounder base). Polarity reverses when activated.
- Signaling line circuit (SLC) to next device
- Signaling line circuit (SLC) from previous device
- Power-limited and supervised
- Internal connections

Typical application

Figure 3 shows a typical application. Here, each detector operates its sounder base. The SIGA-CRR is used to activate *all* sounders, according to system programming rules. The CR control relay is optional, and is used to disable or silence the sounders.

Figure 3: Typical application

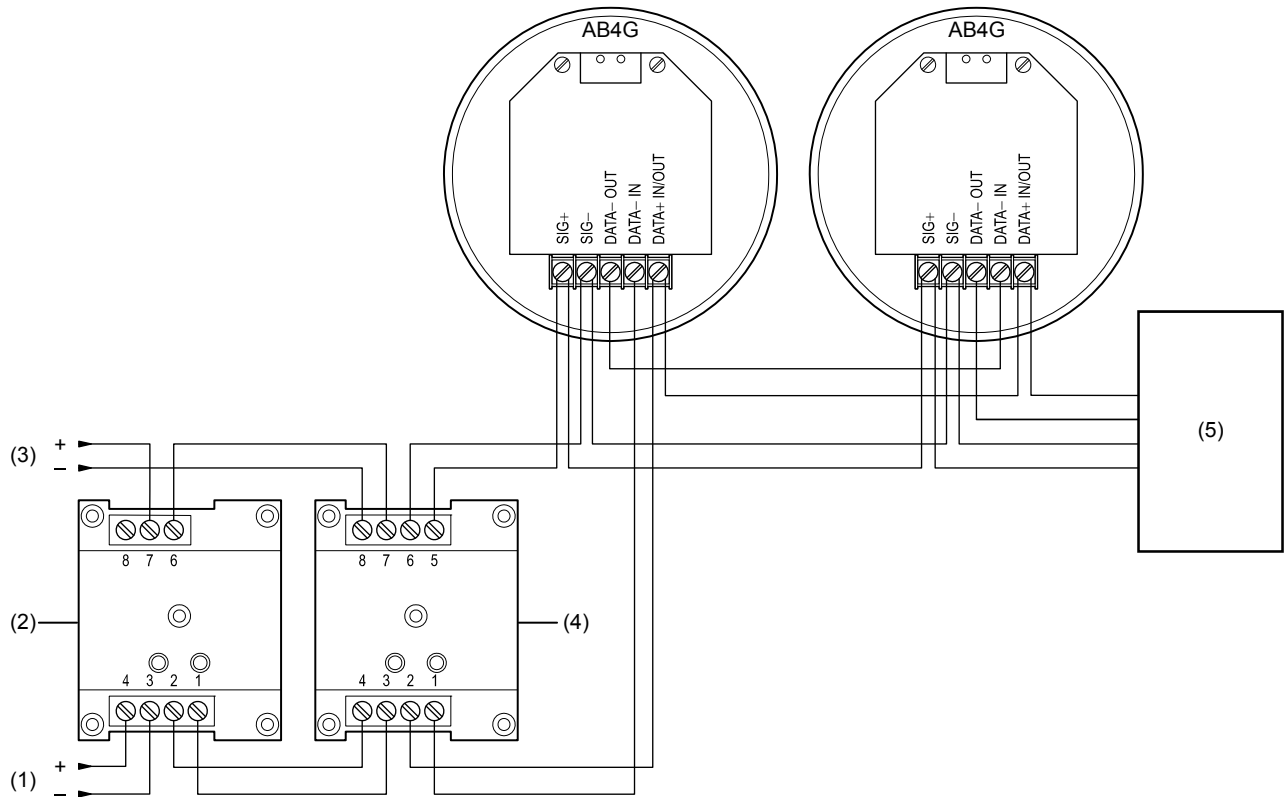

- (1) Signaling line circuit (SLC) from previous device
- (2) SIGA-CR module
- (3) Auxiliary riser in (24 VDC from regulated power supply listed for fire protective signaling)
- (4) SIGA-CRR module
- (5) Riser monitor module or equivalent supervisory circuit

Specifications

Operating voltage	15.20 to 19.95 VDC
Current	
Standby	75 μ A
Activated	75 μ A
Ground fault impedance	10 k Ω
Contact rating (pilot duty)	24 VDC at 2 A
Circuit designation	
Signaling line circuit	Class A, Style 6 or Class B, Style 4
Compatible bases	SIGA-AB4, SIGA-AB4G
LPCB/CPD electrical box Requirements	Plastic box with cover plate, no gaps or unused holes
Minimum W \times H \times D	2.4 \times 3.5 \times 1.5 in. (60 \times 85 \times 38 mm)
Compatible electrical boxes	2-1/2 in. (64 mm) deep single-gang box; 4 in. square box, 1-1/2 in. (38 mm) deep, with single-gang cover
Wire size	12 to 18 AWG (0.75 to 2.5 mm ²)
Operating environment	
Temperature	32 to 120°F (0 to 49°C)
Relative humidity	0 to 93%, noncondensing

Storage temperature range -4 to 140°F (-20 to 60°C)

Regulatory Information

Manufacturer	Edwards, A Division of UTC Fire & Security Americas Corporation, Inc. 8985 Town Center Parkway, Bradenton, FL 34202, USA Authorized EU manufacturing representative: UTC Fire & Security B.V. Kelvinstraat 7, 6003 DH Weert, Netherlands
Year of manufacture	The first two digits of the DATE MFG number (located on the product identification label) are the year of manufacture.
FCC compliance	This device complies with part 15 of the FCC Rules. Operation is subject to the following two conditions: (1) This device may not cause harmful interference, and (2) this device must accept any interference received, including interference that may cause undesired operation.
North American standards	CAN/ULC-S527, UL 864
European standards	EN 54-18: 2005 Input/output devices

Certification



CPD certificates

0832-CPD-1018



2002/96/EC (WEEE directive): Products marked with this symbol cannot be disposed of as unsorted municipal waste in the European Union. For proper recycling, return this product to your local supplier upon the purchase of equivalent new equipment, or dispose of it at designated collection points. For more information, see: www.recyclethis.info.

Contact information

For contact information, see www.utcfireandsecurity.com.