



PFC-3002TW Stock No. 3002001
PFC-3002TR Stock No. 3002002



*Call for Additional Listings

Features

- Two Class 'B' initiating circuits
- One Class 'B' indicating circuit
- Individual Zone Silence/Disconnect switches
- Powerful 3mA capacity per zone for 2-wire smoke detectors
- Common alarm Relay contact, Form C, 28 VDC @ 3 AMP (Resistive)
- Selectable 'N.O' or 'N.C' common trouble contact 28 VDC @ 3 Amp (Resistive)
- A.C. ON LED (Green)
- Zone Alarm LED (Red)
- Signal Trouble LED (Amber)
- Ground Fault LED (Amber)
- Battery Fault LED (Amber)
- Alarm Silenced LED (Amber)
- Common Trouble LED & Silence switch
- Remote Trouble Indicator output
- Remote A.C. On output
- Selectable 1 minute Signal silence inhibit
- Extensive Transient Protection on all circuits
- Exterior color: Red or Beige
- All circuits are power limited

The PFC-3002T panel is designed for non-coded fire alarm systems in small commercial, institutional and industrial occupancies.

The PFC-3002T includes one circuit board providing all the essentials for a complete fire alarm system. Two Class 'B' initiating circuits and one Class 'B' indicating circuit are provided by the PFC-3002T. The indicating circuit is protected from shorts by self-restoring circuitry.

Supervision includes ground fault detection, battery low level or open wire fault, initiating and indicating circuit wiring faults and loss of A.C. power. Initiating circuits are supervised for opens and ground faults. Indicating circuits are supervised for opens, shorts and ground faults. LED indicators are provided for Zone Alarm, Zone Trouble, A.C. On, Battery Fault, Ground Fault, Common Trouble, Signal Trouble and Signal Silenced. Switches are provided for Zone disconnect/silence, trouble silence and reset.

The PFC-3002T has selectable audible tones which can be configured via DIP switches for Steady and Temporal Code.

The panel also includes a common alarm relay which is configurable (via jumper) to follow the signal circuit or lock on until the alarm has been reset.

The controls are behind a durable locked door. The cabinet will accommodate a 4 or 8 AH battery pack.

LEGEND: PULL STATION SMOKE DETECTOR HEAT DETECTOR HORN

NOTE: ALL CIRCUITS ARE POWER LIMITED

NOTE: ALL CIRCUITS ARE POWER LIMITED

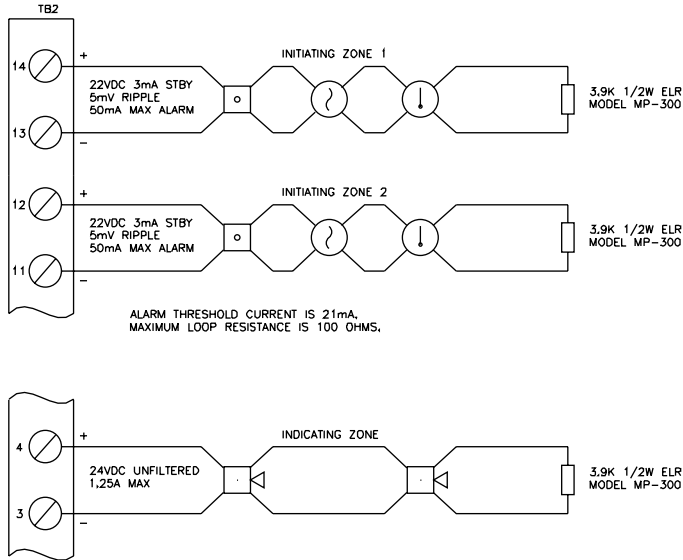

INITIATING AND INDICATING WIRING INSTRUCTIONS

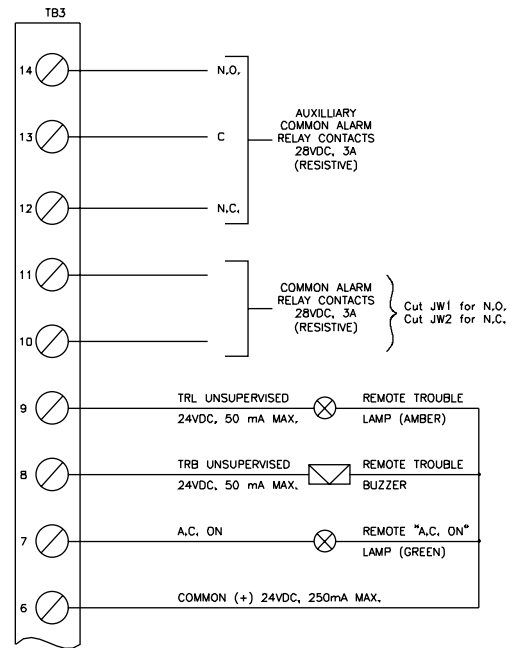

DWG #8900100

ALARM AND TROUBLE RELAY CONTACTS, AND REMOTE ANNUNCIATION WIRING INSTRUCTIONS

Technical Specifications

Initiating Circuits

Output Voltage	22 VDC, filtered and regulated.
Current Limited	50 mA
Supervisory Current	3 mA (up to 30, 2-wire smoke detectors @ 100 uA each)
Loop Resistance	100 ohms, max
End of Line Resistor	3.9Kohm + 5%, 1/2W

Indicating Circuits

Output Voltage	24 VDC
Output Current	1.7A
End of Line Resistor	3.9Kohm + 5%, 1/2W
Auxiliary Contacts	28 VDC, 3A (Resistive)
Dimensions	13.7"(347mm)W x 12.7"(322mm)H x 2.8"(71 mm)D

Ordering Information

Stock No.	Model	Description
3002001	PFC-3002TW	Two Zone Fire Alarm Panel (Beige cabinet)
3002002	PFC-3002TR	Two Zone Fire Alarm Panel (Red cabinet)
3002140	PRTI-1	Remote Trouble indicator, mounts onto a single gang electrical box
3002145	PFC-3000TR	Flush Mounting Trim Ring
5130092	BT-40	12V / 4.0 AH Battery (2 Required)