

# Cerberus<sup>®</sup> PRO Detectors and Peripherals

## Multi-Criteria Fire Detector Model OH921

### Architect & Engineer Specifications

- UL 268 7th Edition Listed
- Built-in isolation (optional configurable)
- Each detector is self-testing:
  - complete diagnostics performed every 10 seconds
  - self-monitored for sensitivity within UL Listed limits
- Listed, approved as a heat detector:
  - Rate-of-Rise Detection: 15°F / min. (8.3°C / min.)
  - Fixed: 135°F (57°C)
- Superior electromagnetic interference (EMI) and radio-frequency interference (RFI) immunity
- Field programmable as rate-of-rise or fixed temperature, per `Alarm Source 2` | Standard parameter
- Tri-color detector-status light-emitting diode (LED) with 360° view
- Compatible with Model 8720 | DPU (device programmer / loop tester)
- Polarity insensitive via SureWire™ technology (in non-isolator mode)
- Functions with Model DB-11-series mounting bases
- Restriction of Hazardous Substances (RoHS compliant)
- Automatic environment compensation
- UL Listed | FM, CSFM Approved
  - UL 268: `Open Area Smoke Detection`
  - UL 268A (Duct) - `Direct-in-Duct` use
  - UL 521: `Open Area Heat Detection`
  - ULC-S531: `Open Area Smoke Detection`
  - ULC-S539: `Open Area Heat Detection`
  - FM 3230: `Open Area Smoke Detection`
  - FM 3210: `Open Area Heat Detection`
  - CSFM | File: 7272-0067:0258

### Product Overview

The Photoelectric | Thermal (Heat) Detector (Model OH921) is an intelligent, addressable multi-criteria detector that incorporates optical and thermal sensors, and uses signals in a neural network to create an intelligent multi-criteria detector. The encompassing result is a detector that provides enhanced detection to a wide range of products of combustion.

Model OH921 is UL 268 7th Ed. listed and incorporates advanced built-in isolation (optionally configurable), which greatly improves reliability, circuit integrity and provides advanced addressable fault finding.

The multi-criteria detector also has state-of-the-art microprocessor circuitry (with error check), as well as detector self-diagnostics and supervision programs that is used on Cerberus PRO Modular | FireFinder XLS/V and on Model FC/FV9-series Cerberus PRO fire-alarm control panels (FACPs).

Additionally, Model OH921 is a plug-in and addressable two-wire multi-criteria detector (with both photoelectric and thermal sensors) that is compatible with Siemens intelligent, addressable systems.

### Operation

Model OH921 utilizes an infrared light emitting diode (IRLED), and infrared light-sensing photodiode. Under normal conditions, light transmitted by the LED is directed away from the photodiode and scattered through the smoke chamber in a controlled pattern.

The smoke chamber is designed to manage light dissipation and extraneous reflections from dust particles or other non-smoke, airborne contaminants in such a way as to maintain stable, consistent detector operation. When smoke enters the detector chamber, light emitted from the IRLED is scattered by the smoke particles, and is received by the photodiode.

Model OH921 also utilizes a modern, accurate and shock-resistant thermistor to sense temperature changes.

The signal processing with detection algorithms allows the detector to first gather smoke and thermal data, and then analyze this information in the detector's `neural network.` By comparing data received with the common characteristics of fires or fire signatures, Model OH921 can compare these signals to those of deceptive phenomena that cause other detectors to trigger a false alarm.

Each Model OH921 detector provides three (3) pre-programmed parameter sets that can be selected by the FACP.



**Model OH921**  
Multi-Criteria Fire Detector



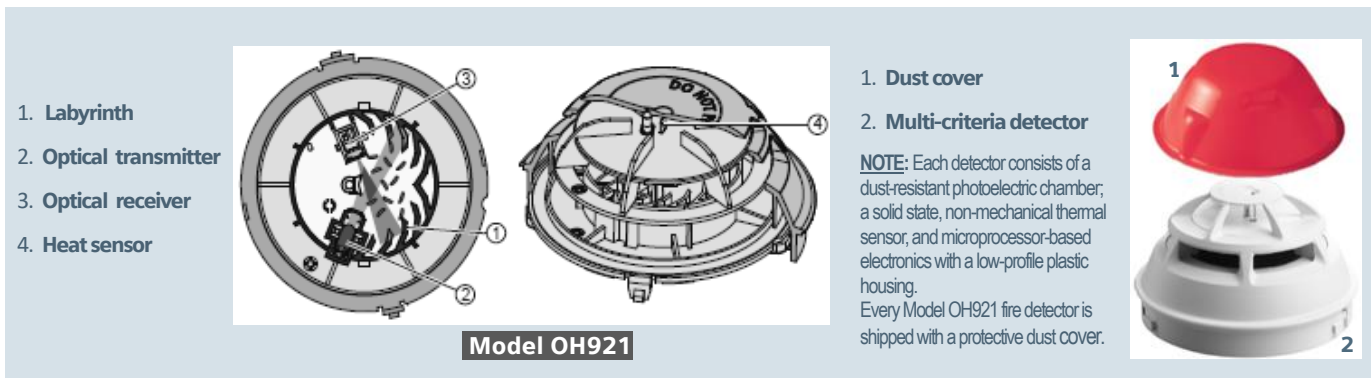

## Profile Overview

Model OH921 provides two (2) different alarm sources that can be selected individually (ON or OFF) by the control panel.

Alarm Source 1 (Neural Network) – Combines smoke (heat) with the following field-selectable profiles:

- Standard
- Duct

**Standard:** This parameter set, which is practically ideal for normal office, hotel-lobby-type applications, is the default setting. This parameter set additionally offers improved resistance to false alarms in areas where misleading deceptive sources and helps reduce cooking nuisance alarms (UL 268 7th Ed. Listed)

**Duct:** When using this detector direct in air duct applications, be sure the detector is set to the parameter “Duct”.

Alarm Source 2 (Thermistor) – Heat only; provides the following:

- Static / fixed at 135°F (57°C), default setting
- Rate-of-Rise detection at 15°F / min. (8.3°C / min.)

If the detector is not programmed, Model OH921 will default to a ‘standard’ profile setting, which allows operation for a normal office-type environment. Model OH921 contains a tri-color LED indicator, capable of flashing any one (1) of three (3) distinct colors: GREEN | YELLOW | RED. During each flash interval, the microprocessor-based detector monitors the following fire-system conditions:

- Smoke in its sensing chamber
- Smoke sensitivity is within the range indicated on the nameplate label
- Internal sensors and electronics

Based on the results of the monitoring, the LED indicator flashes the following:

FLASH COLOR	CONDITION	FLASH INTERVAL [in seconds]
GREEN*:	Normal supervisory operation. Smoke sensitivity is within rated limits.	10
YELLOW:	Detector is in trouble and needs replacement.	4
RED:	‘Alarm’ condition	1
NO FLASH:	Detector is not powered.	–

\* denotes LED can be turned OFF  
Please follow the corresponding description of the panel used.

A quick visual inspection is sufficient to indicate the condition of the detector at any time. If more detailed information is required, a printed report can be provided from the respective Cerberus PRO Modular | Model FC9-series | FireFinder XLS/V FACPs that indicates the status and settings assigned to each individual detector.

## Installation

All Model OH921 detectors use a surface-mounting base, Model DB-11 or Model DB-11E, which mounts on a 4-inch (10.2 cm.) octagonal, square or single-gang electrical box. The base utilizes screw-clamp contacts for electrical connections and self-wiping contacts for increased reliability.

The Model DB-11 detector base can be used with the optional Siemens Model LK-11 detector locking kit, which contains 50 detector locks and an installation tool to prevent unauthorized removal of the detector head. Model DB-11 has aesthetically conducive plugs to cover the outer mounting-screw holes.

Model OH921 may be installed on the same initiating circuit with the following [when used with Cerberus PRO Modular | Model FC9-series | FireFinder XLS/V FACP] –

- HFP-11, HFPT-11
- Model `XTRI'-series interfaces
- Model `HTRI'-series interfaces
- Model `HMS'-series manual stations
- Model HCP output-control detection devices
- Model `HZM'-series of addressable, conventional zone modules

All Model OH921 detectors are approved for operation within the UL-specified temperature range of 32°F to 100°F (0 –38°C).

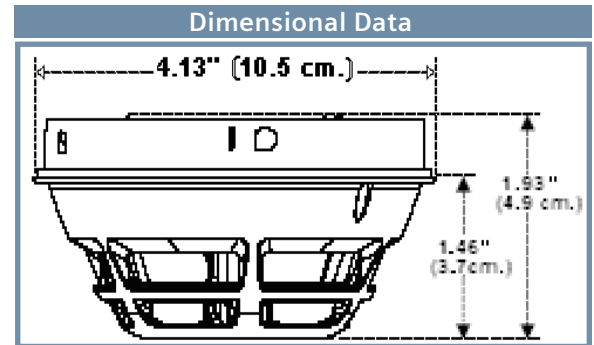

## Application Data

Installation of Model OH921 intelligent, addressable multi-criteria detectors requires a two-wire circuit. In many retrofit cases, existing wiring may be used. `T-tapping' is permitted only for Style 4 (Class B) wiring. Model OH921 is polarity insensitive, which can greatly reduce installation and debugging times.

Model OH921 can be applied within the maximum 50-foot (15.24 m.) center spacing (2,500 sq. ft. [232.2 sq. m.]) per Underwriters' Laboratories. This application guide is based on ideal conditions, specifically, smooth-ceiling surfaces, minimal air movement, and no physical obstructions between potential fire sources and the actual detector. Do not mount detectors positioned near to heating | ventilation | air-conditioning (HVAC) outlets. Exposed joists or beamed ceilings may also affect safe spacing limitations for detectors.

Should questions arise regarding detector placement, observe NFPA 72 guidelines. Good fire-protection system engineering and common sense dictate how and when fire detectors are installed and used. Contact your local Siemens – Fire Safety distributor or sales office whenever you need assistance applying Model OH921 in unusual applications.

Be sure to follow NFPA guidelines and UL Listed / ULC Listed installation instructions – included with every Siemens – Fire Safety detector – and local codes for all fire-protection equipment.

## Specifications

Model OH921 is a plug-in, (2) two-wire thermal (heat) detector, compatible with Cerberus PRO Modular | Model FC9-series FACP] | FireFinder XLS/V. Each Model OH921 detector has microcomputer-chip technology and highly stable, solid-state electronic circuitry. Model OH921 detectors utilize a modern, accurate and shock-resistant thermistor to sense temperature changes. This electronic-sensing method virtually eliminates thermal lag associated with mechanical temperature-sensing devices, and provides almost instantaneous temperature status to the FACP.

Model OH921 provides seven (7) field-selectable, pre-programmed temperature settings:

- Fixed 135°F (57°C)
- Rate-of-Rise: 15°F / min. (8.3°C)

This feature is compatible with Cerberus PRO Modular systems, as well as with Cerberus PRO FC /FV922 or FC /FV924 and FireFinder XLS/V FACP.

## Field-Device Programmer / Test Unit

Model OH921 is compatible with the Siemens field-device programmer / test unit (Model 8720 | DPU), which is a compact, portable and menu-driven accessory for electronically programming and testing these addressable detectors promptly and reliably. For instance, the field technician selects the accessory's program mode, and enters the desired address.

Model DPU eliminates the need for cumbersome, unreliable mechanical programming methods (e.g. – dials and rotary switches), and reduces installation and service costs by electronically programming and testing the detector prior to installation. When set in 'test' mode, Model DPU will perform a series of diagnostic tests without altering the address or other stored data, allowing technicians to determine if the detector is operating properly.

Each field-device programmer / test unit operates on AC power or rechargeable batteries, providing flexibility and convenience in the programming / testing of fire-safety equipment from practically any location. Additionally, with the use of a Model DPU unit, there is no longer a cause for concern with any vibration, corrosion and other deteriorating conditions that can accompany the vitality of a mechanical-addressing mechanism.

The encompassing result is an intelligent detector that provides enhanced detection capability to a wide range of products of combustion – while offering unsurpassed rejection to nuisance-alarm sources, including: dust | steam | aerosols and other deceptive phenomena that could cause false alarms.

Technical Data	
<b>OPERATING TEMPERATURE:</b>	+32° – +100°F (0° – +38°C)
<b>RELATIVE HUMIDITY:</b>	0 – 95% (non-condensing)
<b>AIR PRESSURE:</b>	No effect
<b>INPUT VOLTAGE RANGE:</b>	16VDC – 30VDC
<b>'ALARM' CURRENT, MAX.:</b>	410µA
<b>'STANDBY' CURRENT, MAX.:</b>	250µA
<b>MAXIMUM SPACING:</b>	30–ft. (9.144 m.) centers (900 sq. ft.   83.6 sq. m.), per NFPA 72 and ULC-S524
<b>THERMAL RATING:</b>	<ul style="list-style-type: none"> <li>Fixed 135°F (57°C)</li> <li>Rate-of-Rise: 15°F / min. (8.3°C) at fixed 135°F (57°C)</li> </ul>
<b>DETECTOR WEIGHT:</b>	0.317 Lbs. (0.144 kg.)
<b>MECHANICAL PROTECTION GUARD:</b>	UL Listed / ULC Listed with STI Guard Model STI-9604
<b>SENSITIVITY RANGE:</b>	<ul style="list-style-type: none"> <li>UL268 3.52-4.17% / ft obs.</li> <li>ULC 3.52-4.27% / ft obs.</li> <li>UL268A 2.32-2.84% / ft obs. (direct in-duct)</li> </ul>

Panel Compatibilities		
MODEL OR TYPE	DATA SHEET	PANEL
XLS	<b>6300</b>	FireFinder® (fire-only overview)
XLSV	<b>6340</b>	FireFinder (fire w/ voice)
CERBERUS PRO MODULAR	<b>8300</b>	Cerberus PRO Modular (system overview)
FC901	<b>9813</b>	Cerberus PRO 50-point addressable
FC922	<b>9815</b>	Cerberus PRO 252-pt. addressable (fire)
FC924		Cerberus PRO 504-pt. addressable (fire)
FV922	<b>9821</b>	Cerberus PRO 252-point addressable (fire w/ Intelligent Voice Communication [IVC])
FV924		504-pt. addressable (fire w/ Intelligent Voice Communication [IVC])

Details for Ordering		
MODEL OR TYPE	PART NUMBER	PRODUCT
OH921	S54320-F6-A2	Addressable Multi-Criteria Fire Detector
<b>Compatible Devices:</b>		
MODEL OR TYPE	PART NUMBER	PRODUCT
ABHW-4B	S54320-F13-A1	Sounder base with Loop-Power Option
ABHW-4S	S54320-F14-A1	Sounder base for Sleeping Areas
ADB-BOX	500-698360	Surface Mount Adapter Box for Audible Base
DB2-HR	S54370-F12-A1	Relay base compatible with Siemens standard and advanced detectors
DB-11	500-094151	Detector Mounting Base (for Series 11)
DB-11E	500-094151E	Detector Base (small)
RL-HW	500-033310	Remote Alarm Indicator: Single-gang-box mount, <b>red</b>
RL-HC	500-033230	Remote Alarm Indicator: 4" (10.2 cm.) octagon-box mount, <b>red</b>
LK-11	500-695350	Base Locking Kit (for Series 11)
See: <a href="http://www.STI-USA.com">www.STI-USA.com</a> for further details on ordering Model STI-9604		
<b>In Canada order:</b>		
MODEL OR TYPE	PART NUMBER	PRODUCT
DB-11C	500-095687	Detector Mounting Base, ULC Listed

This Page Left Intentionally Blank

**NOTICE** – The information contained in this data-sheet document is intended only as a summary, and is subject to change without notice.

The product(s) described here has/have a specific instruction sheet(s) that cover various technical, limitation and liability information.

Copies of install-type, instruction sheets – as well as the *General Product Warning and Limitations* document, which also contains important data, are provided with the product, and are available from the Manufacturer.

Data contained in the aforesaid type of documentation should be consulted with a fire-safety professional before specifying or using the product.

Any further questions or assistance concerning particular problems that might arise, relative to the proper functioning of the equipment, please contact the Manufacturer.

**SIEMENS**

## Cerberus® PRO

Siemens Industry, Inc.  
Smart Infrastructure - Building Products  
8 Fernwood Road • Florham Park, NJ 07932  
Tel: (973) 593-2600

June - 2020  
(Rev. 13)