

# Instructions

Eagle Quantum Premier®

Fire and Gas Alarm Control System and Automatic  
Releasing for Pre-Action and Deluge Systems

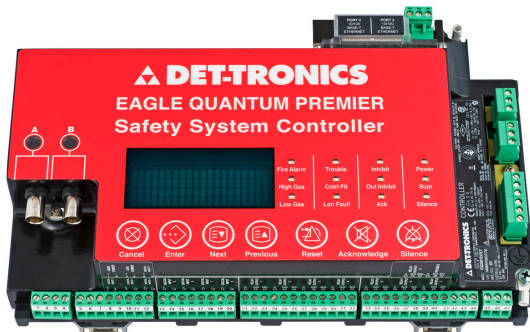

# Table of Contents

## Section 1 - Safety

ALERT MESSAGES.....	1-1
---------------------	-----

## Section 2 - Introduction

SYSTEM DESCRIPTION .....	2-1
Communications Loop .....	2-1
LON Communication Heartbeat .....	2-2
Theory of Operation .....	2-3
Controller Logs .....	2-4
Controller User Logic .....	2-4
Communication Network Fault Operation .....	2-4
Multiple Wiring Faults .....	2-5
SIL2 Capable System.....	2-5
MAJOR COMPONENT DESCRIPTIONS.....	2-6
System Controller .....	2-6
Controller Redundancy .....	2-6
Ethernet Interface Board .....	2-7
Serial Interface Board .....	2-7
EQ2230 RSP Surge Protector.....	2-7
ControlNet Board or Ethernet DLR Board .....	2-7
Controller-to-Controller Communication .....	2-8
EQP Marine Application System .....	2-8
Local Operating Network (LON).....	2-8
Network Extender (NE).....	2-8
Physical Layer Repeater (PLR) .....	2-8
EQ21xxPS Series Power Supplies and EQ2100PSM Power Supply Monitor.....	2-9
EQP21xxPS(-X) Power Supplies and EQP2410PS(-P) Converter.....	2-9
EQ2220GFM Ground Fault Monitor.....	2-9
Field Devices.....	2-9
Flame Detectors .....	2-9
EQ2200 UVHT + C7050 Detector .....	2-9
Model HD Heat Detector .....	2-10
U5015 Explosion-Proof Smoke Detector .....	2-10
X7050 xWatch Explosion-Proof Camera.....	2-10
EQ3730EDIO Enhanced Discrete I/O Module .....	2-10
EQ3700 8 Channel DCIO Module .....	2-10
EQ3720 8 Channel Relay Module .....	2-11
EQ3710AIM Analog Input Module.....	2-11
EQ3770 Explosion-Proof I/O (EIO) Module .....	2-12
EQ3760ASM Addressable Smoke and Heat Module... 2-12	
EQ3750ASH Addressable Smoke and Heat Module... 2-13	
EQ22xxARM Agent Release Module.....	2-13
EQ22xxSAM Signal Audible Module.....	2-14
EQ22xxIDC Series Initiating Device Circuit.....	2-14
UD10 DCU Emulator .....	2-15
EQ22xxDCU and EQ22xxDCUEX Digital Communication Units.....	2-15
PIRECL PointWatch Eclipse .....	2-16
LS2000 Line-of-Sight.....	2-16
EQ3900 Series Fire and Gas Alarm Control Panel and Pre-Action System Solutions .....	2-16
EQ3900RPS Explosion-Proof Power Supply .....	2-16

EQ3780HSDM High Speed Deluge Module.....	2-16
--	------

## Section 3 - Installation

SAFETY SYSTEM DESIGN REQUIREMENTS.....	3-1
Identifying the Area of Protection .....	3-1
Identifying Wiring, Network (LON), and System Power Requirements .....	3-1
General Wiring Requirements .....	3-1
Power Wiring .....	3-1
System Wiring (ATEX and IECEx).....	3-1
Determining Power Requirements.....	3-3
EQ211xPS, EQ213xPS and EQ217xPS Power Supplies .....	3-5
Backup Battery.....	3-5
Battery Charger .....	3-5
EQP21x0PS(-X) Power Supplies .....	3-5
EQP2410PS(-P) Converter.....	3-6
Determining Power Requirements.....	3-6
Shield Grounding .....	3-7
Junction Box Grounding.....	3-7
Response Time vs. System Size .....	3-7
Moisture Damage Protection.....	3-7
Electrostatic Discharge .....	3-7
GROUND FAULT MONITOR (GFM) INSTALLATION.....	3-8
Mounting.....	3-8
Wiring .....	3-8
NETWORK & NETWORK EXTENDER INSTALLATION... 3-8	
Mounting.....	3-8
Wiring .....	3-8
EQ3XXX CONTROLLER INSTALLATION .....	3-10
Enclosure Requirements .....	3-10
Mounting.....	3-11
Serial Interface Board.....	3-11
Ethernet Interface Board .....	3-11
Wiring .....	3-11
Power Wiring .....	3-11
Electrical Connections .....	3-11
Controller to Controller Communication .....	3-16
Configuration .....	3-20
Software Defined Addresses.....	3-20
EQ3XXX REDUNDANT CONTROLLER INSTALLATION .....	3-22
Enclosure Requirements .....	3-22
Mounting.....	3-22
Wiring .....	3-22
LON Wiring .....	3-22
High Speed Serial Link (HSSL) .....	3-23
Configuration .....	3-23
S <sup>2</sup> Configuration.....	3-23
Controller Addresses.....	3-23
RS-485/RS-232.....	3-23
ControlNet .....	3-23
Ethernet DLR .....	3-23

# Table of Contents – Continued

Ethernet .....	3-23
EQ21XXPS SERIES POWER SUPPLY AND POWER SUPPLY MONITOR INSTALLATION.....	3-23
Mounting.....	3-24
Wiring .....	3-24
Startup.....	3-24
Measuring Battery Voltage and Charging Current.....	3-25
EQP2XX0PS(-X) POWER SUPPLIES AND REDUNDANCY MODULE INSTALLATION .....	3-26
Mounting.....	3-26
Wiring .....	3-26
Startup.....	3-29
EDIO MODULE INSTALLATION.....	3-29
Configuration.....	3-33
8 CHANNEL DCIO INSTALLATION .....	3-34
Mounting.....	3-34
Wiring .....	3-35
Configuration.....	3-38
8 CHANNEL RELAY MODULE INSTALLATION.....	3-38
Mounting.....	3-38
Wiring .....	3-39
Configuration.....	3-39
ANALOG INPUT MODULE INSTALLATION .....	3-40
Mounting.....	3-40
Wiring .....	3-40
Configuration.....	3-41
GAS DETECTOR LOCATION AND INSTALLATION .....	3-42
Environments and Substances that Affect Gas Detector Performance .....	3-42
EQ22xxDCU Digital Communication Unit used with Det-Tronics H2S/O2 Sensors or other Two-Wire 4-20 mA Devices.....	3-43
Assembly and Wiring Procedure.....	3-43
Sensor Separation for DCU with H2S and O2 Sensors.....	3-45
EQ22xxDCU Digital Communication Unit used with PointWatch/DuctWatch.....	3-45
Assembly and Wiring Procedure.....	3-45
Sensor Separation for DCU with PointWatch .....	3-45
EQ22xxDCUEx Digital Communication Unit (used with Det-Tronics Combustible Gas Sensors) .....	3-46
Mounting .....	3-46
Wiring .....	3-46
Sensor Separation with DCUEx .....	3-47
TYPICAL APPLICATIONS.....	3-48
SYSTEM CONFIGURATION .....	3-50
Setting Device Network addresses.....	3-50
Overview of Network Addresses.....	3-50
Setting Field Device Addresses.....	3-50
Rocker Switch Table.....	3-51
Physical Disconnect Switch Wiring.....	3-53
Wiring Between EDIO and HSDM Modules .....	3-53

## Section 4 - Operation

SYSTEM CONTROLLER .....	4-1
Pushbuttons.....	4-1
Controller Status Indicators.....	4-2
Text Display .....	4-2
Controller Menu Options .....	4-2
Controller Audible Alarm.....	4-6
ControlNet Status Indicators (Optional) .....	4-7
Ethernet DLR Status Indicators (Optional).....	4-7
Sequence of Events During a Configuration Data Download.....	4-8
Controller Redundancy .....	4-9
ENHANCED DISCRETE I/O MODULE.....	4-11
Power-Up Sequence .....	4-11
8 CHANNEL DCIO MODULE .....	4-12
Power-Up Sequence .....	4-12
8 CHANNEL RELAY MODULE .....	4-13
Power-Up Sequence .....	4-13
ANALOG INPUT MODULE.....	4-14
Power-Up Sequence .....	4-14
EQ21XXPSM POWER SUPPLY MONITOR.....	4-15
EQ2220GFM GROUND FAULT MONITOR.....	4-15
EQ22XXDCU AND EQ22XXDCUEX DIGITAL COMMUNICATION UNITS .....	4-16
EQ24XXNE NETWORK EXTENDER/EQ24XXPLR PHYSICAL LAYER REPEATER .....	4-16
SYSTEM STARTUP .....	4-17
Pre-Operation Checks.....	4-17
General Start-up Procedures .....	4-18
Startup Procedure for Controller .....	4-19
Startup Procedure for EDIO Module .....	4-19
Startup Procedure for DCIO Module.....	4-20
Relay Module Startup.....	4-21
Analog Input Module Startup .....	4-21

# Table of Contents – Continued

## Section 5 - Maintenance

ROUTINE MAINTENANCE .....	5-1
Batteries .....	5-1
Manual Check of Output Devices .....	5-1
O-Ring Maintenance .....	5-1
GAS SENSOR MAINTENANCE .....	5-1
CALIBRATION AND ADJUSTMENTS .....	5-2
Calibration Algorithm A for Manual Calibration of Universal DCU .....	5-2
Normal Calibration .....	5-2
Sensor Replacement .....	5-3
Calibration Algorithm C for Combustible Gas DCUs and Automatic Calibration of Universal DCUs .....	5-3
Routine Calibration .....	5-3
Initial Installation and Sensor Replacement — Combustible Gas .....	5-4
Sensor Replacement — Toxic Gas .....	5-5
Calibration Algorithm D for Universal DCUs with O2 Sensor .....	5-5
Normal Calibration .....	5-5
Sensor Replacement .....	5-5
Calibration Algorithm G for DCUs with PointWatch or DuctWatch .....	5-6
Routine Calibration .....	5-6
Sensor Replacement .....	5-6
DEVICE CALIBRATION LOGS AND RECORDS .....	5-7
TROUBLESHOOTING .....	5-7
REPLACEMENT PARTS .....	5-7
DEVICE REPAIR AND RETURN .....	5-7
ORDERING INFORMATION .....	5-9
Power Supplies .....	5-9
LON Devices .....	5-9
Redundancy .....	5-9
Controller Communication Cables .....	5-9

## Section 6 - Specifications

EQ3XXX Controller .....	6-1
EQ3LTM LON Termination Module .....	6-3
EQ3730EDIO Enhanced Discrete I/O Module .....	6-3
EQ3700 DCIO Module .....	6-5
EQ3720 Relay Module .....	6-7
EQ3710AIM Analog Input Module .....	6-7
HART Interface Module .....	6-8
EQ21xxPS Power Supplies .....	6-8
EQP2xx0PS(-x) Power Supplies .....	6-9
Redundancy Module Quint-Diode/40 .....	6-9
EQ2230 RSP Module .....	6-9
EQ21xxPSM Power Supply Monitor .....	6-10
EQ2220GFM Ground Fault Monitor .....	6-10
EQ22xxDCU Series Digital Communication Unit .....	6-11
EQ24xxNE Network Extender/EQ24xxPLR Physical Layer Repeater .....	6-12
EQ3760ASM Smoke & Heat Module .....	6-13
EQ3780HSMD High Speed Deluge Module .....	6-13
Combustible Gas Sensor .....	6-13
Electrochemical Sensors .....	6-13
UD10-DCU Universal Display .....	6-13
EQ21xxPS Power Supply .....	6-13

## Section 7 - Ordering Information

















DEVICE MODEL MATRICES .....	7-1
-----------------------------	-----

## Appendix

APPENDIX A — FM CERTIFICATION (FIRE AND GAS PERF., HAZLOC) .....	A-1
APPENDIX B — CSA CERTIFICATION (GAS PERF., HAZLOC) .....	B-1
APPENDIX C — ATEX/CE AND IECX CERTIFICATION .....	C-1
APPENDIX D — DNV CERTIFICATION (GAS PERF., HAZLOC) MARINE .....	D-1
APPENDIX E — CE MARK .....	E-1



# Equipment Safety Symbols

Symbol	Description
	Direct current
	Alternating current
	Both direct and alternating current
	Three-phase alternating current
	Earth (ground) current
	Protective conductor terminal
	Frame or chassis terminal
	On (power)
	Off (power)
	Equipment protected throughout by double insulation or reinforced insulation
	Caution, possibility of electric shock
	Caution, hot surface
	Caution*
	In position of bi-stable push control
	Out position of bi-stable push control
	Ionizing radiation

\* Manufacturer to state that documentation must be consulted in all cases where this symbol is marked.

**Fire and Gas Alarm Control System and Automatic Releasing for Pre-Action and Deluge Systems****Section 1  
Safety****ALERT MESSAGES**

The following Alert Messages, **DANGER**, **WARNING**, **CAUTION**, and **IMPORTANT** are used throughout this manual and on the system to alert the reader and operator to dangerous conditions and/or important operational or maintenance information.



*Identifies immediate hazards that **WILL** result in severe personal injury or death.*



*Identifies hazards or unsafe practices that **COULD** result in severe personal injury or death.*



*Identifies hazards or unsafe practices that **COULD** result in minor personal injury or damage to equipment or property.*

**IMPORTANT**

*A brief statement of fact, experience, or importance that is given as an aid or explanation.*



*The hazardous area must be de-classified prior to removing a junction box cover or opening a detector assembly with power applied.*

1. Be sure to read and understand the entire instruction manual before installing or operating the Eagle Quantum Premier® system. Only qualified personnel should install, maintain or operate the system.

2. The wiring procedures in this manual are intended to ensure proper functioning of the devices under normal conditions. However, because of the many variations in wiring codes and regulations, total compliance with these ordinances cannot be guaranteed. Be certain that all wiring and equipment installation meets or exceeds the latest revisions of the appropriate NFPA Standards, National Electrical Code (NEC), and all local ordinances. If in doubt, consult the Authority Having Jurisdiction (AHJ) before wiring the system.

All wiring shall be installed in accordance with the manufacturer's recommendations.

3. Some Eagle Quantum Premier® devices contain semiconductor devices that are susceptible to damage by electrostatic discharge. An electrostatic charge can build up on the skin and discharge when an object is touched. Always observe the normal precautions for handling electrostatic sensitive devices, i.e., use of a wrist strap (if available) and proper grounding.

4. To prevent unwanted actuation, alarms and extinguishing devices must be secured prior to performing system tests.

## Section 2 Introduction

### SYSTEM DESCRIPTION

The EQP system is a combined fire and gas safety system that is globally approved for hazardous locations. It is a distributed releasing system and is certified for annunciation and releasing.

The system consists of a Controller and a number of addressable microprocessor based field devices. The Controller coordinates system device configuration, monitoring, annunciation, and control, while the field devices communicate their status and alarm conditions to the Controller.

The EQP controller can be arranged in a redundant configuration, thereby increasing the availability of the system. The controllers work in "Master" and "Hot Standby" mode.

Various combinations of field devices can be configured as part of the system. The actual selection depends on the requirements of the application and the regulations that cover the type of protection required. See Figure 2-1 for a block diagram of the Eagle Quantum Premier® system.

All field devices are tied into a communication loop that starts and ends at the Controller. Each device connected to the communication loop is assigned a unique identity by setting its address switches. All other device operation parameters are configured through Det-Tronics "Safety System Software." These selections define the type of device and how it is to operate. This system configuration data is then downloaded into the Controller.

A programmed Controller is configured to automatically download the configuration data into the individual devices when they first communicate with the Controller.

In addition to Det-Tronics advanced flame and gas detectors, Eagle Quantum Premier® offers the capability of incorporating third party fire and gas protection equipment into the system. These can be either input or output devices. Typical input devices include manual fire alarm "call boxes," heat detectors, and analog combustible or toxic gas measurement instruments. Typical output equipment includes

solenoids, strobes, and horns. All equipment is monitored for wiring fault conditions.

For complete system integration, the Controller has the capability to communicate with other systems such as PLCs and DCSs. Different communication protocols are supported, allowing the Controller to communicate with other systems either directly or through communication gateways.

#### NOTE

*For specific information relating to the SIL 2 rated EQP system, refer to manual number 95-8599.*

### COMMUNICATIONS LOOP

Eagle Quantum Premier® utilizes a Det-Tronics Signaling Line Circuit (SLC), a version of Echelon's Local Operation Network (LON) customized specifically for Eagle Quantum Premier®. This network provides several key advantages:

- ANSI/NFPA Class X performance of SLC
- Peer-to-peer communications
- Short message formats
- Expandability

The Controller utilizes several mechanisms to continuously check the LON loop for fault conditions, thereby providing the highest level of reliable communication.

Every device on the LON loop has the ability to communicate with the Controller at any time. This design allows immediate alarm messages to be sent from the field devices to the Controller.

All messages are kept short in order to maximize network performance. This minimizes network bottlenecks.

The Eagle Quantum Premier® system is easily modified to accommodate design changes or plant expansions. This can involve adding LON sections, repositioning LON sections, or removing LON sections from the loop. There are LON communication implementation details that affect and limit how the LON loop is changed.

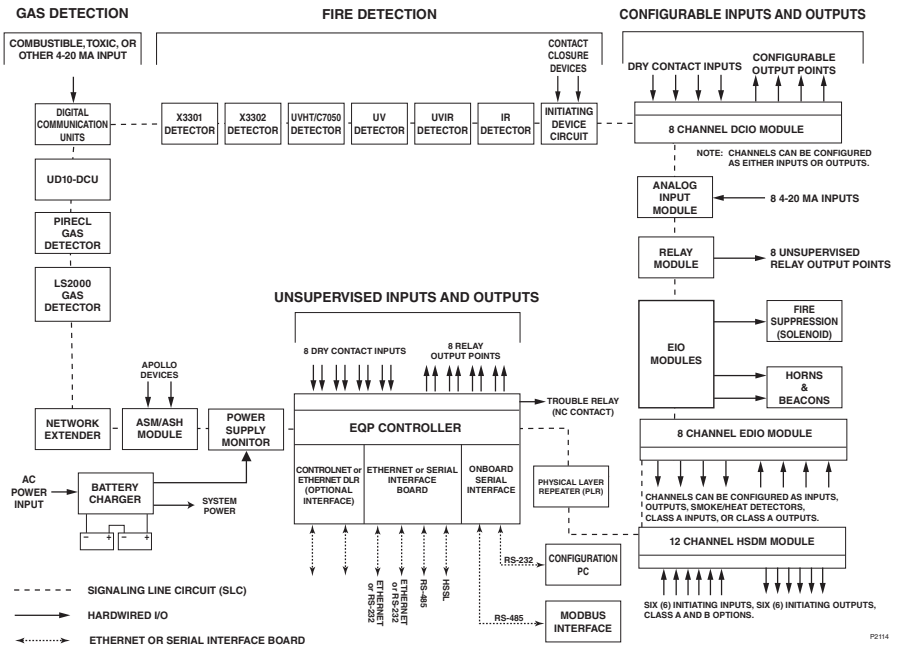

Figure 2-1—Block Diagram of Eagle Quantum Premier® System

Only devices that have been approved for use with Eagle Quantum Premier® can be connected up to the LON. All approved devices have been tested and certified to operate properly on the LON.

### LON COMMUNICATION HEARTBEAT

The Controller continuously broadcasts a heartbeat signal over the LON loop. This heartbeat is used for verifying the integrity of the LON loop and for keeping the field devices from going into a fault isolation mode. Once every second, the heartbeat contains the current time and date, which are used by the field devices to log status events and calibrations.

The Controller continuously tests LON continuity by sending out a heartbeat on one LON port and then listening for it on the other LON port. The Controller also broadcasts the heartbeat signal in the opposite direction around the loop. This ensures that all field devices, the LON Network Extenders (NE), and communication wiring are correctly passing the digital information around the loop.

The field devices use the heartbeat as a mechanism to ensure that there is a communication path back to the Controller. If the field device does not receive a heartbeat for a period of time, the device will go into a LON fault isolation. In this situation, the device opens one side of the LON and listens for a heartbeat on the other side. If the device doesn't receive a heartbeat, it listens on the other side of the LON and opens the opposite LON connection.

### THEORY OF OPERATION

During normal operation, the Controller continuously checks the system for fault conditions and executes user defined programmed logic that coordinates the control of the field devices. At the same time, the field devices are continuously monitoring for device based fault and alarm conditions.

When a fault condition occurs, the Controller displays the fault condition on the Vacuum Fluorescent Text Display, activates the appropriate fault LED(s), activates the Trouble signal using the Controller's internal enunciator, and de-energizes the Controller's Trouble relay.

Table 2-1—Controller Based Faults

Controller Faults Shown on Text Display	Trouble LED	LON Fault LED	Trouble Relay
Controller Fault	x		x
Device Offline	x		x
Extra LON Device	x		x
Invalid Config	x		x
Lon Fault	x	x	x
LON Ground Fault	x		x
Power Fail 1	x		x
Power Fail 2	x		x
RTC Fault	x		x
Redundancy Fault*	x		x
Hardware Fault	x		x
Memory Fault	x		x

\*Only for controller pair configured for redundancy.

Controller based fault conditions include the Controller status and LON communications such as the heartbeat being sent around the loop and the field device loss of communications. Controller based fault conditions are listed in Table 2-1.

Field device based fault conditions are transmitted to the Controller, where they are then announced. Refer to Table 2-2 for a listing of field device faults. Each field device transmits its status to the Controller on a regular basis.

When an alarm condition occurs, the Controller displays the alarm condition on the text display, activates the appropriate Alarm LED(s), and activates the alarm signal using the Controller's internal annunciator.

Table 2-2—Field Device Based Faults

Field Device Faults Shown on Text Display	Trouble LED	Trouble Relay
290 Volt Fault	X	X
AC Failed	X	X
Battery Fault	X	X
Beam Block	X	X
Calibration Fault	X	X
Channel Open	X	X
Channel Short	X	X
Dirty Optics	X	X
Ground Fault Negative	X	X
Ground Fault Positive	X	X
IR Auto Oi Fault	X	X
IR Fault	X	X
IR Manual Oi Fault	X	X
Low Aux Power Fault	X	X
Missing IR Sensor Fault	X	X
Missing UV Sensor Fault	X	X
Power Supply Fault	X	X
Sensor Fault	X	X
Supply Voltage Fault	X	X
Tx Lamp Fault	X	X
UV Auto Oi Fault	X	X
UV Fault	X	X
UV Manual Oi Fault	X	X
Hardware Fault	X	X
Memory Fault	X	X

Each field device must communicate alarm and fault conditions to the Controller. The timing for transmitting alarms and faults to the Controller is displayed in Table 2-3.

#### NOTE

*All fault and alarm conditions are latched on the Controller. To reset the Controller, conditions indicated on the text display must currently be in the OFF state. Pushing the reset button then initiates a Controller reset. Active alarms will remain through a Controller reset.*

#### CONTROLLER LOGS

The controller has an internal alarm and event log. The logs can be accessed via the S<sup>3</sup> software configuration ports (Configuration Port or Port 3) using a RS-232 serial cable

Table 2-3—Eagle Quantum Premier® Status Update Rates

Controller Type	# of Devices	Input – No Exception	Input – With Exception	Input – With Exception
		U-Series (UV & UVIR)	DCU DCIO, EDIO, HSMD AIM Relay Module ASM/ASH Module X-Series LS2000	PIRECL
EQ3001	1 to 100	1 Second	1 Second	1 Second
	101 to 200	2 Seconds	2 Seconds	1 Second
	201 to 246	2 Seconds	3 Seconds	1 Second
EQ3150	1 to 50	1 Second	1 Second	1 Second
	51 to 100	2 Seconds	2 Seconds	1 Second
	101 to 150	2 Seconds	3 Seconds	1 Second
EQ3016	1 to 16	1 Second	1 Second	1 Second

and a Windows™ computer. The controller can save up to 4,095 alarms and events in the controller memory.

### CONTROLLER USER LOGIC

The Controller continuously executes the user logic programs that are programmed using S<sup>5</sup> software. The user logic programs are set up in the same fashion as IEC 61131-3 programmable logic programmed into Programmable Logic Controllers (PLCs). Block diagram logic gates are tied together with inputs, outputs, and other logic gates to perform a specific task. A number of tasks can be tied together to perform a system function.

Typical programmed functions include flame/gas voting, timing delays, timing executions, latching conditions, alarm and trouble notification, suppression control, condition control, and process shutdown notification.

The Controller executes program logic by starting with the first logic page of the first program and then progressing onto subsequent pages of the same program. In turn, subsequent programs are then executed.

Every one hundred milliseconds, the Controller will start executing the user logic that is programmed into the Controller. Within this logic execution cycle, the Controller

will execute as many of the logic pages as possible. If all programmed logic is executed in a cycle, the Controller will start executing program logic with the next cycle. Otherwise, subsequence logic execution cycles are used to finish executing the remaining logic gates. Only when all the logic gates have been executed will the Controller start over. The Controller will start executing the first logic page of the first program at the beginning of the next logic cycle.

### COMMUNICATION NETWORK FAULT OPERATION

During normal operation, the Controller is continuously broadcasting a heartbeat around the communication loop as shown in Figure 2-2. The Controller broadcasts the heartbeat in both directions. At the same time, the field devices are transmitting status information to the Controller over the communication loop.

Every field device except the network extender has two LON fault isolation relays. Each relay is tied to a communication port on the device. When a field device fails to receive the heartbeat from the Controller, the device initiates a LON fault isolation routine. The isolation routine disconnects one of the communication ports via one of the LON fault isolation relays. The device listens for a heartbeat on the communication port that is connected. If

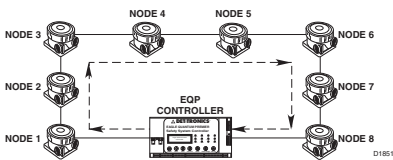

Figure 2-2—Normal Communication over the LON

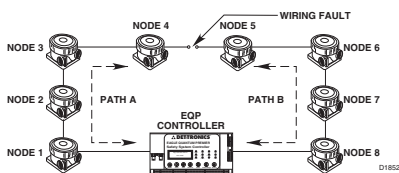

Figure 2-3—Communication over the LON with a Single Wiring Fault

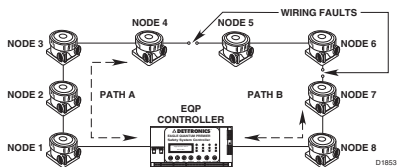

Figure 2-4—Communication over LON with Multiple Wiring Faults

a heartbeat is not found, the routine then disconnects the other communication port and listens for a heartbeat on the connected side. The process is repeated until either a heartbeat is located or a LON fault time out period of two hours is reached.

The LON fault isolation routine is disabled and the LON fault isolation relays are closed when the LON fault timeout period has elapsed. The LON fault isolation routine will be enabled when the device again receives a heartbeat.

For a single wiring fault, the field devices with the fault will isolate the fault by opening LON fault isolation relays. After the field devices isolate the wiring fault, communications will be resumed between the Controller and field devices. Refer to Figure 2-3.

## MULTIPLE WIRING FAULTS

In the event of multiple wiring faults on the LON, the devices between the faults will continue to function, but the faults will prevent them from communicating with the Controller. See Figure 2-4. In this example, nodes 1 to 4 communicate using one Controller port (path A) and nodes

7 and 8 use the other Controller port (path B). Nodes 5 and 6 are unable to report to the Controller because they are isolated by the two wiring faults. If a device is prevented from communicating with the Controller, the text display on the Controller will show the message “Device Offline.”

## IMPORTANT

*Since it is impossible to predict where a network fault might occur or exactly what effect it will have on actual system operation, it is important to diagnose and repair any fault as soon as possible after it is detected to ensure continuous, uninterrupted system operation.*

## SIL2 CAPABLE SYSTEM

The EQP SIL2 capable system uses the following components:

- EQ3XXX - EQP Controller
- EQ3730 - Enhanced discrete input/output module
- EQ3710 - Analog input module
- EQ3760ASM - Addressable Smoke & Heat Module
- X3301 - Multispectrum IR Flame Detector
- PIRECL - Infrared gas detector
- HSDM - High Speed Deluge Module
- UD10-DCU - FlexVu Universal Display

Refer to safety system manual (95-8599) for safety related data.

# MAJOR COMPONENT DESCRIPTIONS

The system has three main component groups – the System Controller, LON (Local Operating Network), and Intelligent Field Devices.

## SYSTEM CONTROLLER

The Controller (see Figure 2-5) performs all communication, command, and control functions for the system. The Controller supports both “Static” and “Programmable” logic. Other features include:

- Redundant controller capability
- User pushbutton controls (reset, acknowledge, etc.)
- “Real time” system clock
- Internal alarm sounder
- Vacuum fluorescent text based display that shows current system status
- 8 programmable unsupervised inputs
- 8 programmable unsupervised relay outputs
- RS-485 Modbus RTU communication interface that supports coils, discrete inputs, and holding registers
- Optional ControlNet communication board supports redundant communication channels.
- Optional Ethernet DLR communication board supports Ethernet Device Level Ring communications.
- Ethernet Interface Board supports configuration, Modbus TCP/IP, controller redundancy, and RS-485 Modbus.
- Serial Interface Board supports configuration, RS-232 Modbus, controller redundancy, and RS-485 Modbus.



Figure 2-5–System Controller

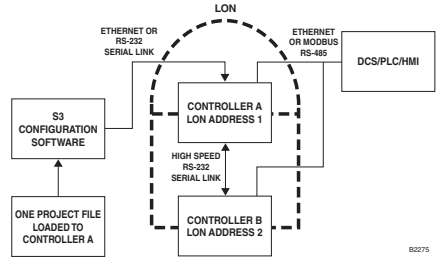

Figure 2-6—Block Diagram of EQP System with Redundant Controllers

## Controller Redundancy

The EQP controllers can be configured as a redundant pair. See Figure 2-6. The redundancy scheme is a hot standby system that offers the following primary features:

- Automatic configuration of the standby controller
- Bumpless transfer
- Forced and automatic switchover
- No downtime on controller replacement
- Automatic synchronization between controllers
- Increased system availability

During normal operation one controller acts as the “Master” while the other acts as the “Hot Standby.”

Terminology used for redundancy:

### Master controller

This is the normal mode for non-redundant and master controllers. User logic is executed, outputs are being controlled and all serial and/or Ethernet ports are active.

### Standby controller

This controller is receiving all inputs but does not have any control over the outputs and user logic is not executed. The standby controller receives update information from the master controller to ensure a bumpless transfer should a controller switchover occur.



Table 2-4—Ports on Ethernet Interface Board

Port Name	Comm	Function
Serial Port 2	RS-485	Modbus (Master/ Slave) Ground Fault Monitored, Isolated
Ethernet Port 3	Ethernet	Modbus TCP/IP (Master/Slave) S <sup>3</sup> Configuration
Ethernet Port 4	Ethernet	ModbusTCP/IP (Master/Slave)
HSSL Redundancy Port	RS-232	Redundant Controller to Controller Only

**Primary controller** The controller assigned address 1.

**Secondary controller** The controller assigned address 2.

**Bumpless transfer** During a controller switchover no change in output will occur due to the switchover.

**Ethernet Interface Board**

The Ethernet Interface Board supports two additional serial ports and two Ethernet ports. See Table 2-4. Ethernet supports 10/100 Mbs communication. Figure 2-7 shows the Ethernet TCP/IP Server/Client and Modbus RTU Master/ Slave relationship. For a redundant controller configuration, the board is required in both controllers.

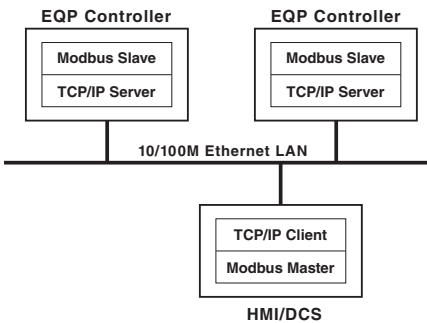

Figure 2-7—Ethernet TCP/IP Server/Client Relationship & Modbus RTU Master/Slave Relationship

**Serial Interface Board**

The Serial Interface Board supports up to four additional serial ports. See Table 2-5. For a redundant controller configuration, the board is required in both controllers.

Table 2-5—Ports on Serial Interface Board

Port Name	Comm	Function
Serial Port 2	RS-485	Modbus (Master/ Slave) Ground Fault Monitored, Isolated
Serial Port 3	RS-232	Modbus (Master/ Slave) S <sup>3</sup> Configuration
Serial Port 4	RS-232	Modbus (Master/ Slave)
HSSL Redundancy Port	RS-232	Redundant Controller to Controller Only

**Q2230 RSP**

The EQ2230 RSP Surge Protector is a device that protects the EQP RS-485 Ports (Ports 1 and 2) from surge transients on the RS-485 cable.

**ControlNet Board or Ethernet DLR Board (Optional)**

An optional ControlNet Board or Ethernet Device Level Ring (DLR) Board can be installed to allow ControlNet or Ethernet DLR communication to a compatible PLC. Both interfaces operate in a non-interfering manner. The functionality of the ControlNet and Ethernet DLR boards is not covered by any approval. Both options offer two ports. See Tables 2-6 and Table 2-7. The interfaces must be configured through S<sup>3</sup> prior to use. Consult the factory for details. For redundant controller configurations, identical option boards are required in both controllers.

Table 2-6—Ports on ControlNet Interface Board

Port Name	Comm	Function
Port A	ControlNet	ControlNet Communication
Port B	ControlNet	ControlNet Communication

Table 2-7—Ports on Ethernet DLR Interface Board

Port Name	Comm	Function
Port 1	Ethernet DLR	Ethernet DLR Communication
Port 2	Ethernet DLR	Ethernet DLR Communication

## Controller-to-Controller Communication (SLC485)

The EQP controllers can be configured to communicate with up to 12 controllers via RS-485 communication. The controller-to-controller scheme provides the ability to meet NFPA 72® SLC requirements with the following primary features:

- Modular trouble and alarm configuration
- Multiple zone application with controller-to-controller communication
- Multiple media options

### **IMPORTANT**

*When using RS-485 communications P8 (Port 1) and P10 (Port 2) wiring must be less than 20 feet and placed into conduit. Or, fiber optic converters (see table 3-9 for performance verified units) shall be used. Or, the EQ2230 RSP can be used to protect against electrical surge and transient EMI. The fiber optic converter and RSP must be placed inside the cabinet with the controller.*

## EQP Marine Application System

For information regarding EQP Marine Application Systems, refer to Appendix D.

## LOCAL OPERATING NETWORK (LON)

The LON is a fault tolerant, two wire, digital communication network. The circuit is arranged in a loop starting and ending at the Controller. The circuit supports up to 246 intelligent field devices spread over a distance of up to 10,000 meters (32,500 feet).

### NOTE

*All LON devices support ANSI/NFPA 72® Class X communication with the Controller.*

*Eagle Quantum Premier® Network Extenders and/or Physical Layer Repeaters may be necessary to establish network segments for communication integrity within a large system. A network segment is the combination of the number of LON network devices and the length*



Figure 2-8—Eagle Quantum Premier® Network Extender/Physical Layer Repeater

*of wire between 2 network extenders or 1 network extender and the Controller. Up to 40 LON network devices may be installed in a network segment, and the LON cable wire segment lengths are dependent upon physical and electrical characteristics of the cable. Refer to the installation section for LON cable wire information.*

## Network Extender (NE)

The purpose of the network extender is to transmit LON communication signals beyond 2,000 meters of wire length. A network extender (see Figure 2-8) must be installed near or at 2,000 meters of wiring length to rebroadcast the communications into the next network segment. For every network extender added, the length of the communications loop extends up to 2,000 meters. Due to propagation delays around the loop, the maximum loop length is limited to 10,000 meters.

## Physical Layer Repeater (PLR)

The purpose of the physical layer repeater is to eliminate communications interference resulting from network wiring opens, caused by a break in the wire or a bad connection. An open wire will result in the reflection of the network signal back along the network wiring segment. This interference has the potential to cause a network device to fault isolate. Depending upon the electrical characteristics of the network cable and quantity of field devices of a network segment, a physical layer repeater may be necessary within a network segment to provide optimal performance and ANSI/NFPA 72® Class X compliance. A physical layer repeater should be installed adjacent to any LON network device experiencing fault isolation as indicated by LON diagnostics.



Figure 2-9—Ground Fault Monitor

### NOTES

*A network extender is required for communication loops greater than 60 nodes or 2000 meters of cable length.*

*Network extenders/physical layer repeaters may be needed to divide the network into smaller segments. No more than six network extenders may be used on the communication loop. Two physical layer repeaters may be installed within a network segment.*

### EQ21xxPS Series Power Supplies and EQ2100PSM Power Supply Monitor

The Power Supply, Power Supply Monitor, and backup batteries are used to provide power to the system. The power supply monitor communicates trouble conditions to the Controller. Monitored status conditions include: power supply failure, loss of AC power, loss of battery power, power ground fault, AC and DC voltage (hi/low level), and backup battery current charge levels.

The Power Supply provides main and backup power to the EQP System. The device includes many features such as voltage regulation, high efficiency, and high power factor.

An equalize switch is located on the front panel of the charger for manual activation, or a multi-mode electronic timer can be used for automatic activation. Steady state output voltage remains within +/- 1/2% of the setting from no load to full load for AC input voltages within +/- 10% of the nominal input voltage.

### EQP21xxPS(-X) Power Supplies and EQP2410PS(-P) Converter

The Power Supplies and Converter provide main and backup power to the EQP System

Detector	Manual Number
X3301	95-8704
X3301A	95-8527 & 95-8534
X3302	95-8576
X5200	95-8546
X2200	95-8549
X9800	95-8554
UVHT	95-8570

Table 2-8—Flame Detector Instruction Manuals

in ordinary and marine applications. Refer to Section 3 of this manual for complete information.

### EQ2220GFM Ground Fault Monitor

The EQ2220GFM Ground Fault Monitor (see Figure 2-9) provides ground fault monitoring in a system that includes a floating 24 Vdc power source. The device detects ground fault conditions on +/- power and all secondary I/O circuits. A positive or negative ground fault condition is indicated immediately by local LEDs, and by a relay contact after a 10 second time delay. The ground fault monitor is intended to be mounted in the same enclosure as the controller.

### FIELD DEVICES

#### Flame Detectors

For flame detector installation, operation, maintenance, specifications and ordering information, refer to Table 2-8.

For information regarding USCG Approval of the X3301 Flame Detector, refer to Appendix D.

#### NOTE

*Existing Eagle Quantum field devices such as EQ22xxUV and EQ22xxUVIR are supported by the Eagle Quantum Premier® system (not FM Approved).*

### EQ2200UVHT + C7050 Detector

The EQ2200UVHT + C7050 UV Flame Detector is used with the EQP system to provide UV flame protection in continuous duty, high temperature applications such as turbine enclosures, generator rooms, etc. where the ambient temperature can continuously exceed

+ 75 deg C (+ 167 def F). The EQ2200 UVHT is an electronic module assembly that is used in conjunction with a high temperature rated C7050B detector.

### Model HD Heat Detector

The Model HD Heat Detector senses the surrounding air temperature and actuates an electrical contact output at a pre-determined temperature. It can be used to sense excessive heat or fire and warn personnel, or it can be used as a signaling device to sense fire and send a signal to an alarm panel for actuation of a fire suppression system.

### U5015 Explosion Proof Smoke Detector

The Det-Tronics SmokeWatch™ U5015 Explosion-Proof Smoke Detector has Division and Zone explosion-proof ratings and is suitable for industrial and commercial applications. It is designed to operate effectively with smoldering and rapidly growing fires. Outputs include a localized LED, 0-20 mA, and relays.

### X7050 xWatch® Explosion-Proof Camera

The xWatch high resolution color camera operates in an explosion-proof enclosure and can be used to view an area in alarm or to record activity in an area. It can be used as a stand-alone unit or attached to any of the X-series flame detectors. Users have an option to include a digital video recorder (DVR) as part of the solution to capture a digital video of hazard events.

### EQ3730EDIO Enhanced Discrete Input/Output Module

The 8 Channel EDIO Module (see Figure 2-10) expands the Input and Output capability of the Eagle Quantum Premier® System.

The unit is designed to provide continuous and automated fire/gas protection, while ensuring system operation through continuous supervision of System Inputs/Outputs.

The EDIO module provides eight channels of configurable input or output points that can be programmed for supervised or unsupervised operation. Each input point can accept fire detection devices such as heat, smoke, or unitized flame detectors. Each output point can be configured for signaling or releasing output operation. Each channel on the module

is provided with individual indicators for active and fault conditions.

### IMPORTANT

*For Class A wiring, two input/output channels are combined, thereby supporting up to four input/output circuits.*

### NOTE

*An input must be active for at least 750 milliseconds in order to be recognized.*

The EDIO module can be mounted directly to a panel, or it can be DIN rail mounted. System status can be determined using the troubleshooting procedures, Eagle Quantum Safety System Software (S<sup>3</sup>) and the status indicators on the module.

Refer to the Enhanced Discrete Input/Output Module Specification Data sheet (form number 90-1189) for additional information.



Figure 2-10—Enhanced Discrete Input/Output Module

### EQ3700 8 Channel DCIO Module

The 8 Channel Discrete Input/Output (DCIO) Module (see Figure 2-11) consists of eight individually configured channels. Each channel is configured as either an input or output with the appropriate wiring supervision. Wiring supervision includes none, open circuits, and "open and short" circuits. In addition to defining the type of supervision, an input channel is also configured to generate the appropriate static logic alarm message to the controller.

### NOTE

*NFPA 72® requires wire supervision selection for fire detection and notification devices (IDC, NAC,*

*supervisory and releasing devices).*

Heat, smoke, or uninitized flame detectors can be wired into channels defined as inputs. Horns and strobes/beacons can be wired into channels defined as outputs.

**NOTE**

*The DCIO outputs only support equipment that operates on 24 vdc (not to exceed 2 amperes per channel).*

The DCIO has two device status LEDs, as well as two LEDs for each channel. On the device level, one green LED indicates power, while the other yellow LED indicates a LON CPU fault. For each channel, one red LED indicates channel activation and the other yellow LED indicates a fault condition when wiring supervision is defined for the channel.

Refer to the DCIO Specification Data sheet (form number 90-1149) for additional information.



Figure 2-11—DCIO Module

**EQ3720 8 Channel Relay Module**

The 8 Channel Relay Module (see Figure 2-12) consists of eight individually configured output channels.

**NOTE**

*The relay module supports equipment that operates on:*

*24 Vdc (not to exceed 1 amperes)*

The relay module has two LEDs for the device and two LEDs for each channel. On the device level, one green LED indicates power, while the other yellow LED indicates a LON CPU fault. For each channel, one red LED indicates channel activation and the other yellow LED

indicates that the module operating voltage is low or that the module has not been configured (all eight channel LEDs blink).

Refer to the Relay Module Specification Data sheet (form number 90-1181) for additional information.



Figure 2-12—Eight Channel Relay Module

**EQ3710AIM Analog Input Module**

The 8 Channel Analog Input Module (see Figure 2-13) provides a means of connecting devices with a calibrated 4–20 mA output signal to the Eagle Quantum Premier® System.

The Analog Input Module (AIM) provides 8 configurable channels that can be set for either combustible gas mode or universal mode. The combustible gas mode provides a number of automatically programmed settings, and alarm thresholds that are limited to approval body requirements. The universal mode is used for generic devices where control over all configuration parameters is required. All devices must provide their own calibration facilities.

For fire detector 4–20 mA inputs, the Analog Input Module (AIM) is certified for use as an NFPA 72® Class B Approved input.

Refer to the Analog Input Module Specification Data sheet (form number 90-1183) for additional information.

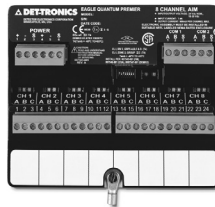

Figure 2-13—Eight Channel Analog Input Module

## EQ3770 Explosion-Proof I/O (EIO) Module

This module includes an EDIO/HSDM/AIM/RM/DCIO module in an explosion-proof enclosure (see Figure 2-14). Options include: Window, NTP/Metric ports, and a Ground Fault Monitor (GFM)

Refer to the EQ3770EIO Instruction Manual (form number 95-8761) for additional information.



Figure 2-14—EIO Module

## EQ3760ASM Addressable Smoke & Heat Module

The EQ3760ASM Addressable Smoke & Heat Module (see Figure 2-15) is an interface device designed to provide continuous and automated fire protection for the EQP system.

The EQ3760ASM is located directly on the LON of the EQP system, with a loop of up to 100 addressable devices tied into the EQ3760ASM. This allows all of the flame, gas, and addressable smoke and heat detectors to run on one system, enabling the EQP controller to annunciate a fire alarm from either its own LON based I/O, or from the connected addressable smoke and heat detection loops. The EQP controller can support up to 10 EQ3760ASM modules.

The EQ3760ASM can support a variety of Apollo Discovery and XP95 devices, including smoke, heat, manual call, sounders, beacons and I/O modules. The addressable devices are configured individually via the S<sup>3</sup> software.

To ensure reliable system operation, the EQ3760ASM continuously monitors its input and output circuits for opens and short circuit conditions.

During normal operation, the EQ3760ASM continuously checks the loop for fault conditions and executes user defined programmed logic that coordinates the control of the field devices. The EQ3760ASM reports any device based fault and alarm conditions to the EQP controller.

The EQP Controller continuously monitors the status of the EQ3760ASM, as well as the status of each device connected to the EQ3760ASM. The EQ3760ASM's alarm and fault status conditions are logged in the EQP controller.

System status can be determined using S<sup>3</sup> software or the status indicators on the EQ3760ASM, where LEDs annunciate power on, faults, or an active device on the loop.

Refer to the EQ3760ASM instruction manual (form number 95-8755) for additional information.

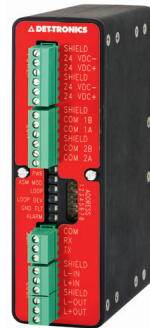

Figure 2-15—EQ3760ASM

## EQ3750ASH Addressable Smoke & Heat Module

The Addressable Smoke and Heat (ASH) Module (see Figure 2-16) is an interface device designed to provide continuous and automated fire protection for the EQP system.

The ASH module is located directly on the LON of the EQP system, with a loop of up to 64 addressable devices tied into the ASH module. This allows all of the flame, gas, and addressable smoke and heat detectors to run on one system, enabling the EQP controller to announce a fire alarm from either its own LON based I/O, or from the connected addressable smoke and heat detection loops. The EQP controller can support up to 10 ASH modules.

The ASH module can support a variety of Apollo Discovery and XP95 devices, including smoke, heat, manual call, sounders, beacons and I/O modules. The addressable devices are configured individually via the S<sup>3</sup> software.

To ensure reliable system operation, the ASH module continuously monitors its input and output circuits for opens and short circuit conditions.

During normal operation, the ASH module continuously checks the loop for fault conditions and executes user defined programmed logic that coordinates the control of the field devices. The ASH module reports any device based fault and alarm conditions to the EQP controller.

The EQP Controller continuously monitors the status of the ASH module, as well as the status of each device connected to the ASH module. ASH module alarm and fault status conditions are logged in the EQP controller.

System status can be determined using S<sup>3</sup> software or the status indicators on the ASH module, where LEDs announce power on, faults, or an active device on the loop.

Refer to the ASH module instruction manual (form number 95-8654) for additional information.



Figure 2-16—EQ3750ASH

## EQ25xxARM Agent Release Module

The EQ25xxARM Series Agent Release Module (ARM) (see Figure 2-17) provides agent release or deluge pre-action capability. The device is controlled by programmable logic in the Controller. Time delay, abort and manual release sequences allow the device output to be programmed for use in unique applications.

The device is field programmed to operate in one of the following modes:

- |               |   |
|---------------|---|
| Timed–        | Output is activated for a field selectable duration from 1 to 65,000 seconds. |
| Continuous–   | Output latches until reset.   |
| Non-latching– | Output follows the input.   |

### NOTE

**Special Condition of Use: For use in systems installed in compliance with NFPA 72®:2010 or earlier.**

The device can monitor and control two output devices (24 Vdc rated) that are programmed and energized together. The release circuits are compatible with a variety of solenoid or initiator based suppression systems.

The release circuit is supervised for open circuit conditions. If a trouble condition occurs (open circuit or solenoid supply voltage less than 19 volts), it will be indicated at the Controller. Each output is rated at 2 amperes and auxiliary input terminals are provided for additional 24 Vdc output power where needed.



Refer to the EQ25xxARM Specification Data sheet (form number 90-1128) for additional information.

**NOTE**

*Special Condition of Use: For use in systems installed in compliance with NFPA 72®:2010 or earlier.*



Figure 2-17—Agent Release Module

**EQ25xxSAM Signal Audible Module**

The EQ25xxSAM Series Signal Audible Module (SAM) (see Figure 2-18) provides two indicating circuits for controlling UL Listed 24 Vdc polarized audible/visual indicating appliances.

The device is located on the LON and is controlled by programmable logic in the Controller.

Each output circuit is independently programmable to allow notification of separate events. Each output can be individually activated for any one of the following pre-defined outputs:

- 1. Continuous
- 2. 60 beats per minute
- 3. 120 beats per minute
- 4. Temporal pattern.

Device outputs operate in the reverse polarity manner when activated. Each output is rated at 2 amperes. Auxiliary power input terminals are provided for additional 24 Vdc signaling power where required. The output circuits are supervised for open and short circuit conditions. If a wiring fault occurs, a trouble condition will be indicated at the Controller. Refer to the EQ25xxSAM Specification Data sheet (form number 90-1129) for additional information

**NOTE**

*Special Condition of Use: For use in systems installed in compliance with NFPA 72®:2010 or earlier.*



Figure 2-18—Signal Audible Module

**EQ22xxIDC Series Initiating Device Circuit (IDC)**

There are three IDC models available (see Figure 2-19):

The **EQ22xxIDC** allows discrete inputs from smoke/heat detectors, manual call stations or other contact devices.

The IDC accepts two dry contact inputs for use with devices such as relays, pushbuttons, key switches, etc. The IDC supports ANSI/NFPA 72@ Class B supervised input circuits

Each circuit requires its own end of line (EOL) resistor for monitoring circuit continuity. Nominal resistance of the resistor is 10 k ohms.

The **EQ22xxIDCGF** Initiating Device Circuit Ground Fault Monitor (IDCGF) responds to the presence of a ground fault within the power circuitry of the system. It provides an unsupervised dry contact input and ground fault monitoring circuitry for indicating a power supply trouble condition. It is intended for use with a third party power supply.

The **EQ22xxIDCSC** Initiating Device Circuit Short Circuit (IDCSC) is similar to the IDC, but supports supervision per EN 54 for European installations.

Refer to the EQ22xxIDC Specification Data sheet (form number 90-1121) for additional information.



#### NOTE

*Input types (e.g. fire alarm, trouble, and gas alarms) are configurable through Det-Tronics Safety System Software (S<sup>2</sup>).*

#### NOTE

*Special Condition of Use: For use in systems installed in compliance with NFPA 72®:2010 or earlier.*



Figure 2-19—Initiating Device Circuit

### UD10 DCU Emulator

The FlexVu<sup>®</sup> Model UD10 DCU Emulator (UD10-DCU) is designed for applications that require a gas detector with digital readout of detected gas levels. Its LON interface board makes the UD10-DCU compatible with Eagle Quantum Premier<sup>®</sup> systems by digitizing the 4-20 mA analog signal from the attached sensor/transmitter and transmitting the value as a process variable over the LON to the EQP controller.

The UD10-DCU is designed for use with most currently available Det-Tronics gas detectors. The UD10-DCU with CGS with conditioning board is designed for use with combustible gas, see manual 95-8656 for more information.

For a list of compatible gas detectors, as well as information regarding installation, operation, maintenance, specifications and ordering information, refer to form number 95-8656.

### EQ22xxDCU and EQ22xxDCUEX Digital Communication Units

The EQ22xxDCU Digital Communication Unit (DCU) is an analog signal input device that accepts a 4–20 mA signal. The device is typically connected to gas detectors,

where the analog signal represents the gas concentration.

Calibration of the DCU involves a non-intrusive procedure that can be performed by one person at the device without declassifying the area.

The device supports two alarm setpoints that are defined as part of the device's configuration setup. When detecting combustible gases, the alarm setpoints represent low and high gas alarm levels. When detecting oxygen, the alarms represent the range for the acceptable oxygen level. If oxygen drops below the alarm range, a low alarm is generated by the device.

PointWatch/DuctWatch IR gas detector as well as electrochemical sensors (hydrogen sulfide, carbon monoxide, chlorine, sulfur dioxide, and nitrogen dioxide) are examples of devices that can be connected to the DCU.

#### NOTE

*A catalytic sensor can be connected to a DCU through a transmitter, which converts the millivolt signal to a 4–20 milliampere signal.*

The EQ22xxDCUEX is a specialized version of the DCU that contains a transmitter for connection to a Det-Tronics Model CGS catalytic combustible gas sensor.

Refer to the EQ22xxDCU Specification Data sheet (form number 90-1118) for additional information.

### PIRECL PointWatch Eclipse

The Pointwatch Eclipse<sup>®</sup> Model PIRECL is a diffusion-based, point-type infrared gas detector that provides continuous monitoring of combustible hydrocarbon gas concentrations in the range of 0–100% LFL.

The LON supervision meets Signaling Line Circuit (Class X) requirements per NFPA72: 2010 for the Model PIRECL.

For PIRECL installation, operation, maintenance, specifications and ordering information, refer to form number 95-8526.

## NOTE

*The low alarm range for the EQP PIRECL is 5–40% LFL (the standard PIRECL is 5–60% LFL).*

For information regarding USCG Approval of the PIRECL Detector, refer to Appendix D.

### LS2000 Line-of-Sight

The FlexSight™ Line-of-Sight Infrared Hydrocarbon Gas Detector Model LS2000 is a gas detection system that provides continuous monitoring of combustible hydrocarbon gas concentrations in the range of 0–5 LFL-meters, over a distance of 5–120 meters.

The LON supervision meets Signaling Line Circuit (Class X) requirements per NFPA 72®: 2010 for the Model LS2000.

For LS2000 installation, operation, maintenance, specifications, and ordering information, refer to form number 95-8714.

### EQ3900 Series Fire and Gas Alarm Control Panel and Pre-Action System Solutions

As part of providing the total solution to commercial and industrial customers globally, Det-Tronics offers several performance approved hazardous area (EQ3900N and EQ3900E) and non-hazardous area (EQ3900G) enclosure solutions. These are custom solutions that can include 1 or more of the following components: EQP controller, EDIO, HSDM, AIM, RM, DCIO, PSM, and GFM. Refer to Instruction Manuals (95-8559 and 95-8641) for additional information.

### EQ3900RPS Explosion-Proof Power Supply

The EQ3900RPS is an industrial power supply that accepts two independent AC inputs and produces 24 Vdc with up to 18 amps output current. It can be configured with various numbers of 24 Vdc power outputs, ground fault test operator, status indicators, fuse monitoring and window. Ordinary location or Class 1 Division 1 enclosure configurations can be provided.

### EQ3780HSDM High Speed Deluge Module

The EQ3780HSDM High Speed Deluge Module (HSDM) is specifically designed

to expand the capability of the Det-Tronics Eagle Quantum Premier® (EQP) System by providing the capability to activate ultra-high speed suppression systems for hazardous applications such as munitions manufacturing.

The HSDM provides up to six (6) configurable input channels and up to six (6) configurable output channels that can be programmed for supervised or unsupervised operation. Typical initiating devices include optical flame detectors, heat detectors, and manual pull stations. Output channels are designed to activate Factory Mutual (FM) approved solenoids. Solenoids that are activated by the HSDM are typically used to initiate pilot-actuated deluge valves.

A unique cascade output feature allows the output of the HSDM to be connected to the input of another HSDM, extending the systems capability to activate multiple solenoids with a single input. Refer to instruction manual 95-8782 for more information.



Figure 2-20 High Speed Deluge Module

## Section 3 Installation

### NOTE

For specific information regarding systems meeting EN54 standards, refer to the EQ5400 Series operation manual 95-8642.

## SAFETY SYSTEM DESIGN REQUIREMENTS

Many factors need to be considered when determining proper EQP System design. The following paragraphs will discuss these factors and other issues useful in designing, installing and configuring the Eagle Quantum Premier® System.

### IDENTIFYING THE AREA OF PROTECTION

In order for the system to provide optimum coverage and protection, it is critical to properly define the required "Area of Protection" (total area being monitored by the system). The area of protection should include all hazard sources requiring monitoring, as well as suitable locations for mounting detection, extinguishing, notification, and manual devices. In order to accurately define the area of protection and provide maximum protection, all potential "Real" and "False" hazard sources must be identified. The number and location of Real Hazards determines the extent of the area of protection, and impacts all subsequent design decisions.



*When drilling through surfaces in the process of mounting equipment, verify that the location is free of electrical wiring and electrical components.*

### IDENTIFYING WIRING, NETWORK (LON), AND SYSTEM POWER REQUIREMENTS

#### General Wiring Requirements



*DO NOT open any junction box or device enclosure when power is applied without first de-classifying the hazardous area.*



*Any deviation from the manufacturer's recommended wiring practices can compromise system operation and effectiveness. ALWAYS consult the factory if different wire types or methods are being considered.*

### NOTE

*All field wiring must be marked per NFPA 70 Article 760.*

### NOTE

*Specific installation requirements may differ depending on local installation practices and compliance with third party certifications. For local installation practices, consult the local authority having jurisdiction. For compliance with third party certifications, consult the appropriate appendix in this manual for additional installation requirements.*

### Power Wiring

#### IMPORTANT

*To ensure proper operation of field devices, the voltage input to the device (measured at the device) must be within the range indicated for that device in the "Specifications" section of this manual (18 Vdc minimum).*

### System Wiring (ATEX and IECEx)

For the interconnection of the modules within the EQP system, use fixed installed wiring. (For correct wiring size and type for a specific device, refer to the appropriate section in this manual.)

For ambient temperatures below  $-10^{\circ}\text{C}$  and above  $+60^{\circ}\text{C}$ , use field wiring suitable for both minimum and maximum ambient temperatures.

The EQP Ex n modules may only be installed, connected, or removed when the area is known to be non-hazardous. The screw terminals are to be tightened with a minimum torque of 0.5 Nm. Equipotential bonding connection facilities on the outside of electrical equipment shall provide effective connection of a conductor with a cross-sectional area of at least  $4\text{ mm}^2$ .

The Eagle Quantum Premier® system utilizes a power supply that provides an isolated 24 Vdc battery backed-up power to the fire protection devices as described in NFPA 72®. More than one power supply may be used in a system to provide power to different sets of equipment as part of the system.

The power supply wiring may consist of one or more daisy-chained wire segments providing power to the devices. For each of the daisy-chained wire segments, the installer must calculate the voltage drops that occur across the devices in order to determine the gauge of the wire that will be installed.

A power supply wiring diagram should contain information describing wire distances and current draws associated with all devices connected to the wire segment. A typical power supply wiring recommendation is that the voltage drop from the power source to the end device should not exceed 10%. Using 24 Vdc as a reference, the maximum voltage drop should not exceed 2.4 Vdc. A wire gauge must be selected to ensure that the end device has at least 21.6 Vdc or higher.

In order to calculate the power supply voltage for the end device, calculate the voltage drops that occur due to each wire segment between the devices. This involves determining the total current draw and the two conductor wire resistance per each wire segment.

**Example:** Can 18 AWG wire be used to power three devices from the 24 Vdc power supply? Refer to the figure below for wiring and device current draw information along with voltage drop calculations.

**Answer:** If the Authority Having Jurisdiction (AHJ) requires a voltage loss of 10% or less, only 16 AWG wire could be used, since the end device would require 21.4 Vdc. If there is no local requirement, then 18 AWG wire could be used to provide power to the devices.

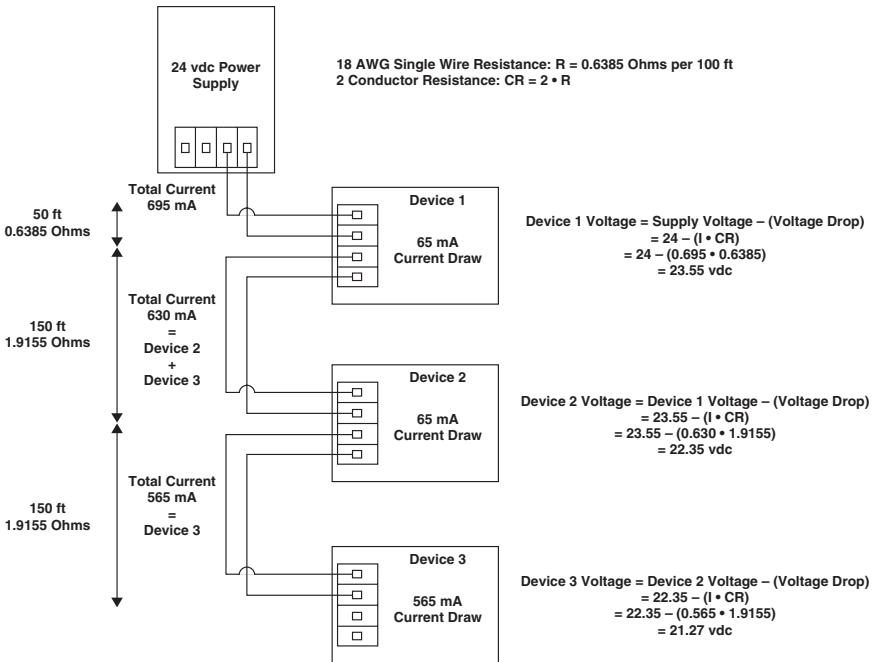

## Determining Power Requirements

Tables 3-1 and 3-2 are provided for calculating the total current requirements for those parts of the system requiring battery backup.

Table 3-1—Standby Current Requirements at 24 Vdc

Device Type	Number of Devices		Standby Current		Total Current for Device Type
EQP Controller		X	0.360	=	
EQ3LTM Module		X	0.001	=	
EDIO Module		X	0.075	=	
HSDM Module		X	0.075	=	
DCIO Module		X	0.075	=	
Power Supply, Monitor		X	0.060	=	
IDC/IDCGF/IDCSC		X	0.055	=	
X3301/X3301A - without heater		X	0.160	=	
X3301/X3301A - with heater		X	0.565	=	
X3302 - without heater		X	0.160	=	
X3302 - with heater		X	0.565	=	
X2200		X	0.135	=	
X9800 - without heater		X	0.085	=	
X9800 - with heater		X	0.420	=	
X5200 - without heater		X	0.155	=	
X5200 - with heater		X	0.490	=	
Relay Module		X	0.120	=	
Analog Input Module		X	0.160	=	
EQ2220GFM		X	0.018	=	
PIRECL		X	0.270	=	
LS2000 Transmitter without heater		X	0.149	=	
LS2000 Transmitter with heater		X	0.336	=	
LS2000 Receiver without heater		X	0.116	=	
LS2000 Receiver with heater		X	0.258	=	
Network Extender		X	0.030	=	
Physical Layer Repeater		X	0.090	=	
ASM/ASH Module		X	0.560	=	
EQ21xxPS Power Supply		X	0.350	=	
UD10-DCU - with heater off		X	0.054	=	
UD10-DCU - with heater on		X	0.167	=	
UD10-DCU CGS - w/ heater off		X	0.221	=	
UD10-DCU CGS - w/ heater on		X	0.333	=	
Other		X		=	
Total <b>Standby</b> Current for System (in amperes)			=		

Notes: Standby current is the average current draw for the device in normal mode.

This table is for battery calculations only.

For OPECL standby current requirements, reference versions 16.1 and earlier of this manual.

Table 3-2—Alarm Current Requirements at 24 Vdc

Device Type	Number of Devices		Alarm Current		Total Current for Device Type
EQP Controller		X	0.430	=	
EQ3LTM Module		X	0.001	=	
EDIO 8 Inputs		X	0.130	=	
EDIO 8 Outputs		X	0.075	=	
HSDM Module		X	0.100	=	
DCIO 8 Inputs		X	0.130	=	
DCIO 8 Outputs		X	0.075	=	
Relay Module		X	0.120	=	
Power Supply Monitor		X	0.060	=	
IDC/IDCGF/IDCSC		X	0.090	=	
X3301/X3301A - w/o heater		X	0.160	=	
X3301/X3301A - with heater		X	0.565	=	
X3302 - without heater		X	0.160	=	
X3302 - with heater		X	0.565	=	
X2200		X	0.135	=	
X9800 - without heater		X	0.085	=	
X9800 - with heater		X	0.420	=	
X5200 - without heater		X	0.155	=	
X5200 - with heater		X	0.490	=	
Analog Input Module		X	0.300	=	
EQ2220GFM		X	0.018	=	
PIRECL		X	0.275	=	
LS2000 Transmitter without heater		X	0.149	=	
LS2000 Transmitter with heater		X	0.336	=	
LS2000 Receiver without heater		X	0.182	=	
LS2000 Receiver with heater		X	0.326	=	
Network Extender		X	0.030	=	
Physical Layer Repeater		X	0.090	=	
EQ3760ASM Module		X	0.560	=	
EQ21xxPS Power Supply		X	0.350	=	
UD10-DCU - with heater off		X	0.054	=	
UD10-DCU - with heater on		X	0.167	=	
UD10-DCU CGS - with heater off		X	0.221	=	
UD10-DCU CGS - with heater on		X	0.333	=	
Other		X		=	
Total Solenoid Load					+
Total Signaling Load					+
Total <b>Alarm</b> Current for System (in amperes) =					

Notes: This table is for battery calculations only.  
 For OPECL alarm current requirements, reference versions 16.1 and earlier of this manual.

Table 3-3A—EQ21xxPS Power Supply Specifications

Characteristic	Power Supply		
	EQ2110PS/EQ2111PS	EQ2130PS/EQ2131PS	EQ2175PS/EQ2176PS
Input Voltage	120 vac	120/208/240 vac	120/208/240 vac
Input Current	4 Amps	11/6/6 Amps	24/15/12 Amps
Input Frequency	60 Hz – EQ2110PS	60 Hz – EQ2130PS	60 Hz – EQ2175PS
Input Frequency	50 Hz – EQ2111PS	50 Hz – EQ2131PS	50 Hz – EQ2176PS
Supply Rating	10 Amps	30 Amps	75 Amps
Maximum Alarm Current	10 Amps	30 Amps	75 Amps
Maximum Standby Current	3.33 Amps	10 Amps	25 Amps
Recharge Current	6.67 Amps	20 Amps	50 Amps
Minimum Battery Capacity	40 AmpHours	120 AmpHours	300 AmpHours
Maximum Battery Capacity	100 AmpHours	300 AmpHours	750 AmpHours
Maximum Deluge Standby Current*	1 Amp	3 Amps	7.5 Amps

\*Only applies to 90 hour back-up applications.

## EQ211xPS, EQ213xPS and EQ217xPS Power Supplies

Refer to Table 3-3A for Power Supply ratings.

### Backup Battery

Refer to Table 3-4 or 3-5 to calculate the minimum size of the backup battery (in amp hours). Select a sealed lead-acid battery with an adequate amp hour rating.

#### NOTE

*Connect two batteries in series for 24 volts. Batteries must be protected from physical damage. The battery installation shall be adequately ventilated.*

### Battery Charger

Use the following formula to calculate the minimum battery charger size:

$$\text{Minimum Charge Rate} = \frac{\text{Alarm Current}}{\text{Current}} + \frac{\text{Total Amp Hours}}{48}$$

### CAUTION

*Care should be taken when considering the final voltage at the device during AC power loss. With loss of AC power, the battery voltage will drop over time as the batteries lose their charge. If extended periods of AC power loss are to be expected, either consider a heavier wire gauge or specify batteries with higher amp-hour ratings.*

### WARNING

*To avoid battery damage adjust float voltage to battery manufacturer recommendations only. Serious injury may result from battery explosion if improperly adjusted.*

## EQP21X0PS(-X) Power Supplies

The EQP2120PS(-B) Power Supply is used in pairs where the primary source of input supply is connected to one and the secondary source is connected to the other. Each power supply may be backed up by another power supply of the same model or by a DC-DC converter (see Figures 3-19A, B and C for available configurations). A maximum of eight power supplies operated in parallel can be connected to each input supply. Both the primary and secondary sets must be individually capable of operating the system without the other supply. The secondary source is required to be continuously powered.

The use of these supplies is based upon acceptance of the local AHJ of the secure supply system that provides the secondary supply. These supplies must be used in a redundant configuration, where one bank of supplies is fed from the primary source and the other bank from the secondary source. Both primary and secondary supplies shall be continuously available and both rated for a minimum 100% of load.

Refer to Table 3-3B for power supply ratings.

Table 3-4—Backup Battery Requirements for Automatic Release of Extinguishing Systems Except Deluge

Standby Current _____	X	Standby Time* 24 Hours	=	Standby Amp Hours _____
Alarm Current _____	X	5 Minute Alarm Time* 0.083 Hours	=	Alarm Amp Hours _____
Sum of Standby and Alarm Amp Hours				=
Multiply by 1.2 (20% Safety Factor)				X

T0014B

Total Battery Amp Hour Requirement

\* FM MINIMUM REQUIREMENT FOR EXTINGUISHING SYSTEMS IS 24 HOURS STANDBY TIME AND 5 MINUTES ALARM TIME.

Table 3-5—Backup Battery Requirements for Deluge and Pre-Action Applications

Standby Current _____	X	Standby Time* 90 Hours	=	Standby Amp Hours _____
Alarm Current _____	X	10 Minute Alarm Time* 0.166 Hours	=	Alarm Amp Hours _____
Sum of Standby and Alarm Amp Hours				=
Multiply by 1.2 (20% Safety Factor)				X

T0040B

Total Battery Amp Hour Requirement

\* FM MINIMUM REQUIREMENT FOR DELUGE SYSTEMS IS 90 HOURS STANDBY TIME AND 15 MINUTES ALARM TIME.

 **IMPORTANT**

*The EQP21X0PS(-X) Power Supplies provide EQP System devices with power from input supply 120 to 220 V ac. Use of this power supply does not provide the source of the secondary supply such as secondary source batteries, their supervision or charging, or UPS. Per NFPA 72®-2013 requirements, such power supply related requirements must be separately provided for and be accepted by the local Authority Having Jurisdiction (AHJ).*

**EQP2410PS(-P) Converter**

The EQP2410PS(-P) Converter converts the DC input voltage to an adjustable, controlled and galvanically separated 24 Vdc output voltage. The converter is always connected to the secondary source.

**Determining Power Requirements**

Use of the EQP2120PS(-B) Power Supply provides the primary and secondary supplies.

The EQP2410PS(-P) Converter provides the secondary supply only. It is used in conjunction with the EQP2120PS(-B) Power Supply, which serve as the primary supply (see Figures 3-19A, B and C for available configurations). The customer is responsible for providing adequate secondary power supply source needs. The ac input current requirements for EQP2XX0PS(-X) in relation to EQP system dc current load (power supply output) are calculated using the following formula:

$$\text{Input Current} = [\text{Output Current} \times \text{Output Voltage} \div \text{Input Voltage} \div \text{Efficiency}] + 0.43 \text{ A}$$

**Example:**

$$[20 \text{ Adc} \times 28 \text{ Vdc} \div 120 \text{ Vac} \div 0.91] + 0.43 = 5.56 \text{ Aac}$$

For Standby Current (amperes ac) requirements, use Total Standby Current (amperes dc) for the system's applicable field devices from Table 3-1.

For Alarm Current (amperes ac) requirements, use Total Alarm current (amperes dc) for the system's applicable field devices from Table 3-2.



Table 3-3B – EQP2X0PS Power Supply and Converter Specifications

Characteristic	EQP2120PS(-B) Power Supply	EQP2410PS(-P) Converter
	Input Frequency	60/50
Input Voltage	120/220 Vac	24 Vdc
Input Current, Max.	6.6 / 3.6 Iac	15.7 Idc
Output Voltage Range	24.5 ... 28.0 Vdc	24.5 ... 28.0 Vdc
Supply Rating	20	10
Maximum Alarm Current	20	10
Maximum Standby Current	20	10
Efficiency	91% for 120 Vac 93% for 220 Vac	88%

**NOTE**

*The suffix (-P) or (-B) defines the method for mounting the panel mount models:  
(-P) = mounting plate  
(-B) = mounting brackets.*

**Shield Grounding**

Two shield ground terminals are provided inside the junction box of each device, and also at the System Controller. Connect shield ends to the terminals provided (not to each other) inside the junction box.



**CAUTION**

*Insulate the shields to prevent shorting to the device housing or to any other conductor. Refer to Appendix E for EMC Directive requirements.*

**Junction Box Grounding**

All junction boxes must be electrically connected to earth ground.

**Response Time vs. System Size**

When designing a system, it is important to realize that by increasing the number of nodes (devices) on the communication loop, the amount of time required for a status change message from a detection device to reach the System Controller also increases.

The System Controller requires a specific length of time to process each bit of information that is transferred along the communication loop. As the number of nodes increases, so does the amount of data being processed as well as the time required for processing by the Controller.

If the fastest possible communication response time is an important criteria for a large system, it is recommended that the number of nodes on an individual loop be kept as small as possible. Consider using multiple controllers with fewer nodes per loop.

**Moisture Damage Protection**

Moisture can adversely affect the performance of electronic devices. It is important to take proper precautions during system installation to ensure that moisture will not come in contact with electrical connections or components.

In applications where the network wiring is installed in conduit, the use of watertight conduit seals, drains, breathers, or equivalent is recommended to prevent damage caused by condensation within the conduit.

**Electrostatic Discharge**

An electrostatic charge can build up on the skin and discharge when an object is touched. ALWAYS use caution when handling devices, taking care not to touch the terminals or electronic components.

 **CAUTION**

ALWAYS discharge static charges from hands before handling electronic devices or touching device terminals. Many devices contain semiconductors that are susceptible to damage by electrostatic discharge.

**NOTE**

For more information on proper handling, refer to Det-Tronics Service Memo form 75-1005.

## GROUND FAULT MONITOR (GFM) INSTALLATION

### Mounting

The GFM is a DIN rail mountable device designed to be mounted in the same enclosure as the EQP controller.

### Wiring

1. Connect power wiring from the EQP controller power terminals 1 and 2 to the GFM terminals 1 and 2.
2. Connect power wiring from the GFM terminals 3 and 4 to the EQP controller power terminals 3 and 4.
3. Connect earth ground to terminal 5 or 10.
4. Connect the relay contacts as required.

Refer to Figure 3-1 for terminal block identification.

## NETWORK AND NETWORK EXTENDER INSTALLATION

### Mounting

The device should be securely mounted to a vibration free surface. (See the "Specifications" section in this manual for device dimensions.)

### Wiring

All devices on the LON are wired in a loop that starts and ends at the System Controller. To ensure proper operation, the LON should be wired using high speed communication grade cable.

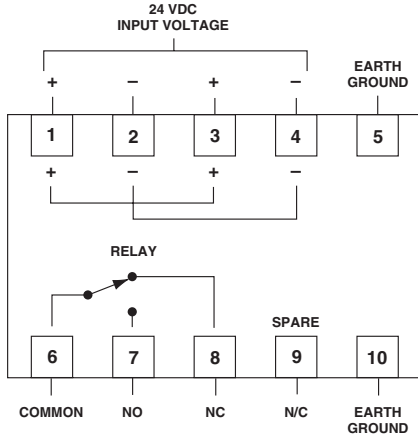

**NOTE:** RELAY CONTACTS ARE SHOWN IN THE REST STATE, NO POWER APPLIED. RELAY IS ENERGIZED WITH POWER APPLIED AND NO GROUND FAULT (TERMINALS 6 & 7 CLOSE, TERMINALS 6 & 8 OPEN).

Figure 3-1—Terminal Configuration for Ground Fault Monitor

**NOTE**

Cable meeting the specifications listed in Table 3-6 is suitable for distances up to 2000 meters.

Any of the cable types listed in Table 3-7 can be used for wiring the LON for the distances indicated.

**NOTE**

If no network extenders are used, the distances listed are for the entire loop. If network extenders are used, the distances listed are for the wiring length between network extenders or between a network extender and the System Controller.

**IMPORTANT**

Det-Tronics recommends the use of shielded cable (required by ATEX) to prevent external electromagnetic interference from affecting field devices.

 **WARNING**

Be sure that the selected cable meets all job specifications and is rated for the installation per local and national codes and practices. The use of other cable types can degrade system operation. If necessary, consult factory for further suggested cable types.

 **IMPORTANT**

Shielded cables certified to ISA SP50 Type A or IEC 61158-2 Type A are suitable for use in LON/SLC wiring. For armored version, contact cable manufacturer.

1. Remove the cover from the Network Extender enclosure.
2. Connect 24 Vdc power lead wires and communication network cable to the terminal block. (See Figure 3-2 for terminal location and Figure 3-3 for terminal identification).

See Table 3-8 to determine maximum wiring length.

COM 1 - Communication network connections: Connect to COM 2 terminals of the next device on the loop, A to A and B to B.

COM 2 - Communication network connections: Connect to COM 1 terminals of the previous device on the loop, A to A and B to B.

LON Cable NPLFA (Manufactured and Part No.)*	Maximum Length**		Voltage
	Feet	Meters	
Belden 3073F (Tray Rated)	6,500	2,000	600 V
Rockbestos Gardex Fieldbus 1 Shield Pair, 16 AWG, Type TC, p/n FB02016-001	6,500	2,000	600 V
1 Shield Pair, 18 AWG, Type TC, p/n FB02018-001	6,500	2,000	600 V

Table 3-7—LON Maximum Cable Lengths

Note: \*Use the same type of cable in each wiring segment between network extenders.

\*\*Maximum wire lengths represent the linear wire distance of LON communications wiring between network extenders.

Be sure that selected cable meets all job specifications, indoor, outdoor and direct burial.

If necessary, consult factory for further suggested cable types.

24 Vdc - Connect the "+" terminal to the positive side of the 24 Vdc power source. (Both "+" terminals are connected internally.)

Connect the "-" terminal to the negative side of the 24 Vdc power source. (Both "-" terminals are connected internally.)

Table 3-6—Typical Specification for 16 AWG (1.5 mm<sup>2</sup>) LON Wiring Cable per Echelon

	Minimum	Typical	Maximum	Units	Condition
DC Resistance, each conductor	14	14.7	15.5	ohm/km	20 C per ASTM D 4566
DC Resistance Unbalanced			5%		20 C per ASTM D 4566
Mutual Capacitance			55.9	nF/km	per ASTM D 4566
Characteristic Impedance	92	100	108	ohm	64 kHz to 1 MHz, per ASTM D 4566
Attenuation	78 kHz		2.2	dB/km	20 C per ASTM D 4566

T0049B

Length: 6,500 feet/2000 meters maximum (basic loop or between Network Extenders).

Type: Single twisted pair.

Wire Gauge: 16 AWG, stranded (19 x 29), tinned copper with overall shield.

Cables meeting these specifications are good for up to 2000 meters.

Table 3-8—Maximum Wiring Length from Nominal 24 Vdc Power Source to Network Extender  
(Maximum wire lengths are based upon the cable's physical and electrical characteristics.)

Wire Size	Maximum Wiring Distance	
	Feet	Meters
18 AWG (1.0 mm <sup>2</sup> )*	2200	650
16 AWG (1.5 mm <sup>2</sup> )*	3500	750
14 AWG (2.5 mm <sup>2</sup> )*	5600	1700

\*Approximate Metric Equivalent.

- Connect shields to the designated "shield" terminals. The two shield terminals are connected internally to ensure shield continuity.



**Do not ground either shield at the network extender enclosure. Insulate the shields to prevent shorting to the device housing or to any other conductor.**

- Check ALL wiring to ensure that proper connections have been made.
- Inspect the junction box O-ring to be sure that it is in good condition.
- Lubricate the O-ring and the threads of the junction box cover with a thin coat of grease to ease installation and ensure a watertight enclosure.

**NOTE**

*The recommended lubricant is a silicone free grease, available from Det-Tronics.*

- Place the cover on the enclosure. Tighten only until snug. **Do not over tighten.**

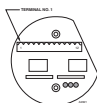

Figure 3-2—Network Extender Wiring Terminal Location

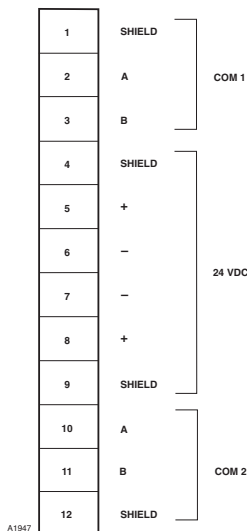

Figure 3-3—Network Extender Wiring Terminal Identification

## EQ3XXX CONTROLLER INSTALLATION

The following paragraphs describe how to properly install and configure the EQ3XXX Controller.

### ENCLOSURE REQUIREMENTS

The Controller must be properly installed in a suitable enclosure that is rated for the location. The enclosure must provide space to install and wire the Controller and must also provide for ground wire termination. The enclosure must contain either a keyed lock or a special tool to gain access into the enclosure. The enclosure should be rated for the temperature range of the location plus the temperature rise of all equipment installed inside the enclosure. The enclosure must be rated for electrical equipment that is going to be installed.

#### NOTE

*The Controller and enclosure must be connected to earth ground.*

For ordinary locations when entry is required to operate the equipment, the cabinet should be a dead-front construction and 16-gauge cold-rolled steel. The door lock system shall accept different keys for entry. An Authorized Persons key and a Person-in-charge key will allow entry into the cabinet. The cabinet should contain a window to view the Controller's text display and LED indicators.

#### NOTE

*For any selected enclosure, the enclosure must conform to all applicable regulations and requirements.*

#### NOTE

*The Trouble signal must be located in an area where it is likely to be heard.*

Classified locations require the appropriate hazardous rated enclosure. It is recommended that operators/switches be installed in the enclosure. This avoids the need to declassify the area in order to operate the Controller. Regulations require that key switches be installed for certain operations. An appropriate window should be part of the enclosure in order to allow an operator to view the text display and LED indicators.

#### NOTE

*If an enclosure does not have a keyed entry, a special tool is required to gain entry into an enclosure.*

Det-Tronics offers several approved (FM/CSA/ATEX/CE) hazardous area enclosures that have Eagle Quantum Premier® equipment installed in the enclosure. Contact Det-Tronics for further information.

## MOUNTING

The Controller is designed for direct panel mounting or DIN rail (optional) mounting. See "Specifications" section of this manual for mounting dimensions.

#### NOTE

*Clips for DIN rail mounting are available, but must be specified at the time of ordering.*

#### NOTE

*A minimum clearance of 4 inches between the Controller and nearby equipment is required to provide room for wiring and ventilation.*

## SERIAL INTERFACE BOARD

A Serial Interface Board is available for the EQP Controller. See Figures 3-6A, 3-6B, and 3-7 for details on the electrical connections.

## ETHERNET INTERFACE BOARD

An Ethernet Interface Board is available for the EQP Controller. See Figures 3-6A, 3-6B and 3-7 for details on the electrical connections.

## WIRING

### Power Wiring



**CAUTION**

*Input voltage at the Controller must be 18 Vdc minimum to ensure proper operation.*

It is important to consider both the wire gauge and the distance from the Controller to the power supply. As the distance between the Controller and the power supply increases, so must the diameter of the power wiring in order to maintain a minimum of 18 Vdc at the Controller.

### IMPORTANT

*To ensure proper operation of devices, the voltage input to the device (measured at the device) must be within the range indicated for that device in the "Specifications" section of this manual.*

### Electrical Connections

Figure 3-6B shows the location of wiring connectors on the Controller module. Figure 3-7 identifies individual terminals.

### Connector P1, Terminals 1 to 4 — 24 Vdc Input Power

Connect the power supply to terminals 1 and 2 of the Controller. Terminals 3 and 4 must also be connected to power.

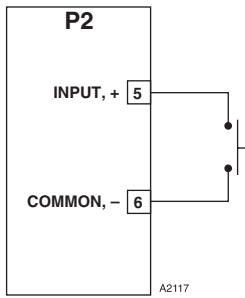

Figure 3-4—Unsupervised Input Wiring

When controller and power supplies are installed in separate NRTL cabinets, two power cables from two distribution circuits are required, so that if one is lost, the controller will continue to operate and signal a trouble condition. The power circuit must be protected against physical damage.

Shields on power cables must be connected to chassis ground (earth).

**Connector P2, Terminals 5 to 12 — Unsupervised Digital Input Channels 1 to 4**

**Connector P3, Terminals 13 to 20 — Unsupervised Digital Input Channels 5 to 8**

See Figure 3-4 for example. Only channel 1 is shown in Figure 3-4. The information is typical for channels 2-8.

**Connector P4, Terminals 21 to 32 — Unsupervised Relay Output Channels 1 to 4**

**Connector P5, Terminals 33 to 44 — Unsupervised Relay Output Channels 5 to 8**

See Figure 3-5 for example. Only channel 1 is shown in Figure 3-5. The information is typical for channels 2-8.

**NOTE**

*Channel software configurations include all panel indicator functions to automatically mimic the controller front panel indicators.*

**Connector P6, Terminals 45, 46 & 47 — Trouble Relay**

The Trouble relay is not configurable. In the normal condition, the relay coil is energized, closing the N.O. contact (terminals 45-46) and

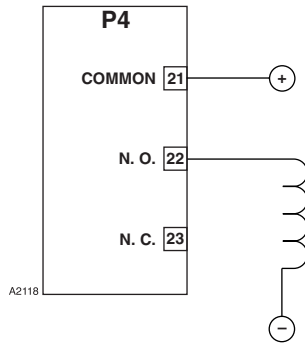

Figure 3-5—Unsupervised Relay Output

opening the N.C. contact (terminals 45-47). The relay coil is de-energized in the trouble condition.

**Connector P7, Terminals 48 to 53 — LON Signaling Line Circuit Terminals**

The LON loop is wired so that the controller's LON COM 1 is connected to the field device's COM 2 connection. The field device's COM 1 is wired to the next device's COM 2 connection. This continues through the last field device on the loop. The last field device's COM 1 is then wired back to the Controller's COM 2 connection. LON A and B polarities must be maintained throughout the loop (i.e., always wire A to A and B to B between the devices).

Port Pinout (6-position connection terminal block)

- 48 — COM 1 shield connection
- 49 — "B" side of signaling circuit for COM 1
- 50 — "A" side of signaling circuit for COM 1
- 51 — COM 2 shield connection
- 52 — "B" side of signaling circuit for COM 2
- 53 — "A" side of signaling circuit for COM 2

**NOTE**

*Refer to Figures 3-10A and 3-10B for location of termination jumpers.*

**Jumper P24 – RS-485 Termination Jumper**

- 1-2 Underterminated
- 2-3 Terminated 121 ohms (factory setting)  
Transceiver input impedance: 68 kohm

**Jumper P25 – LON COM 1 Termination**

- 1-2 COM 1 Terminated (factory setting)
- 2-3 COM 1 Underterminated (Redundancy)

**Jumper P26 – LON COM 2 Termination**

- 1-2 COM 2 Terminated (factory setting)
- 2-3 COM 2 Unterminated (Redundancy)

**Connector P8, Terminals 54, 55 & 56 , Port 1—RS-485 Modbus RTU Master/Slave**

Configuration data downloaded into the controller configures the serial interface transmission baud rate, parity check for the serial port, and Modbus device address.

Software selectable baud rates are 2400, 4800, 9600, 19200, 38400, 57600, and 115200. Software selectable parity is None, Odd, and Even. The controller uses 8 data bits with 1 stop bit.

Port Pinout (3-position terminal block)

- 54 — GND
- 55 — B
- 56 — A

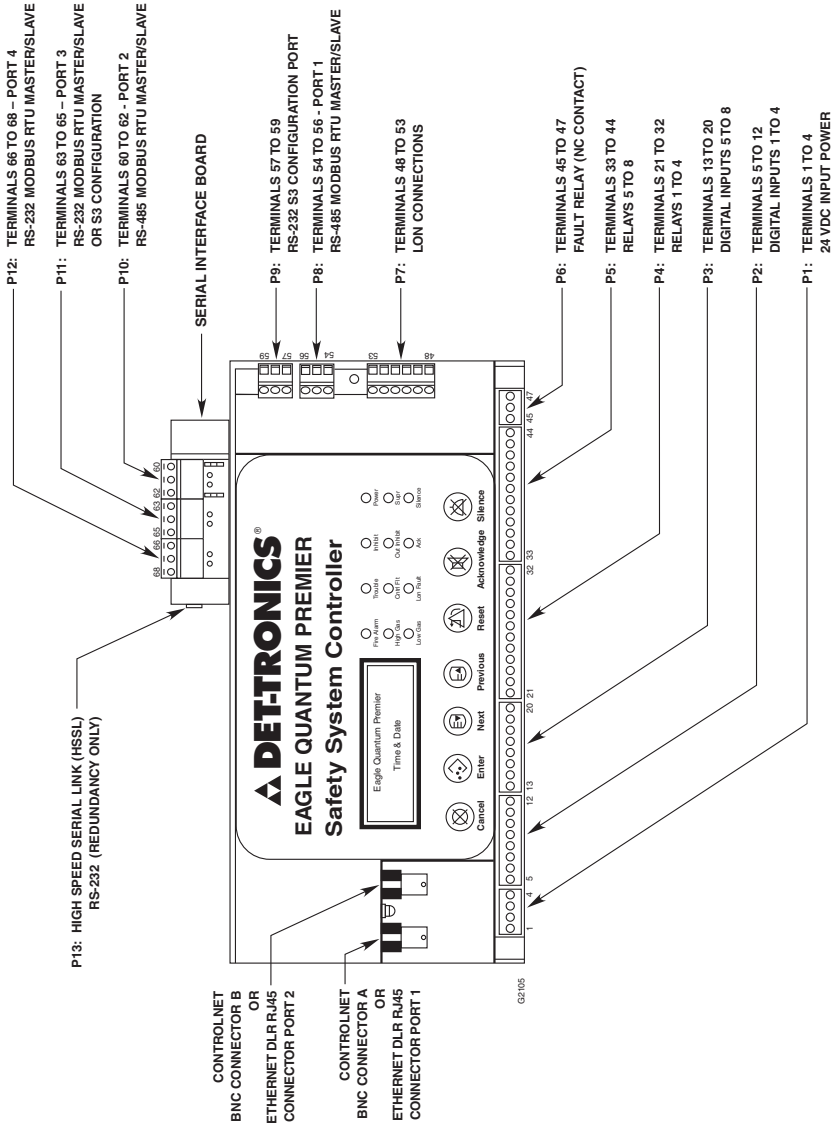

Figure 3-6A—Location of Wiring Terminals on EOP Controller with Serial Interface Board

## Connector P9, Terminals 57, 58 & 59 — S<sup>3</sup> Configuration Port

Configuration data downloaded into the controller configures the serial interface transmission baud rate and parity check for the serial port. Software selectable baud rates are 2400, 4800, 9600, 19200, 38400, 57600, and

115200 (factory default is 115200). Software selectable parity is None, Odd, and Even.

Port Pinout (3-position terminal block)

- 57 — GND
- 58 — RXD
- 59 — TXD

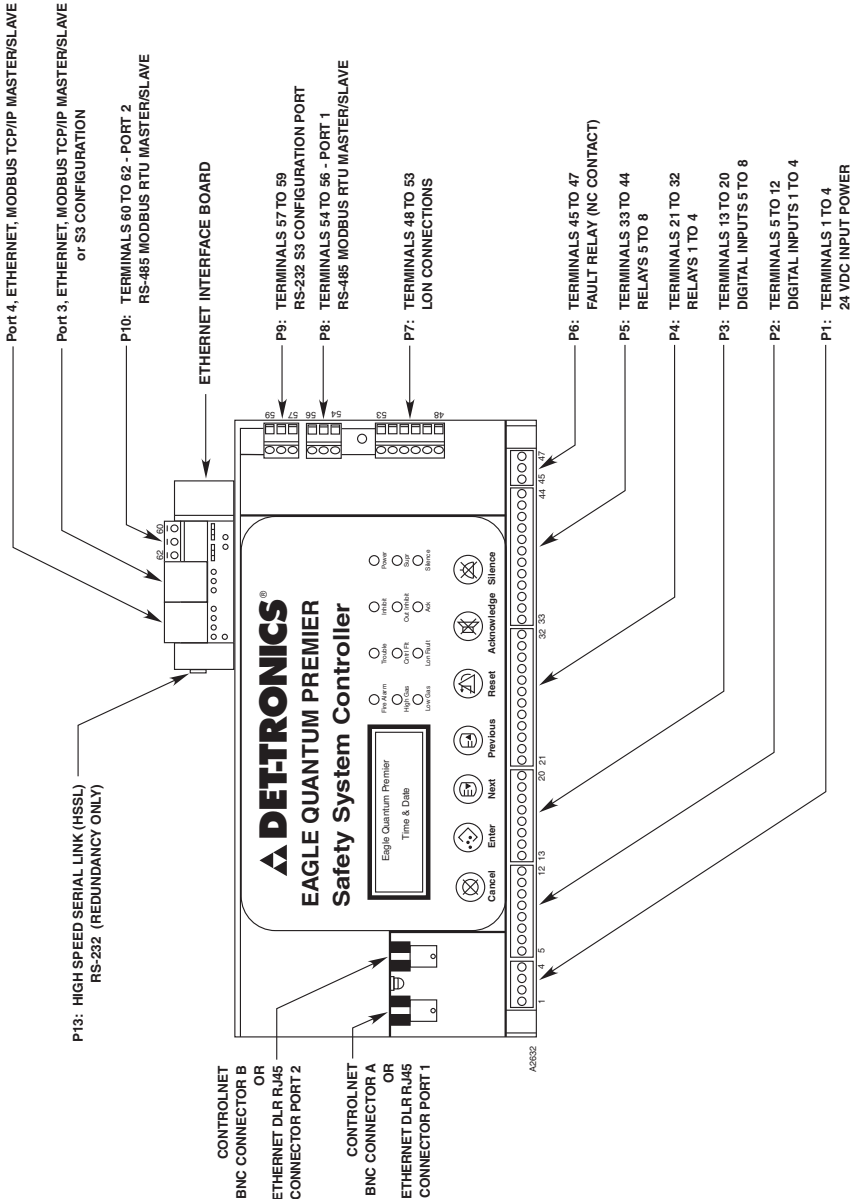

Figure 3-6B—Location of Wiring Terminals on EQP Controller with Ethernet Interface Board



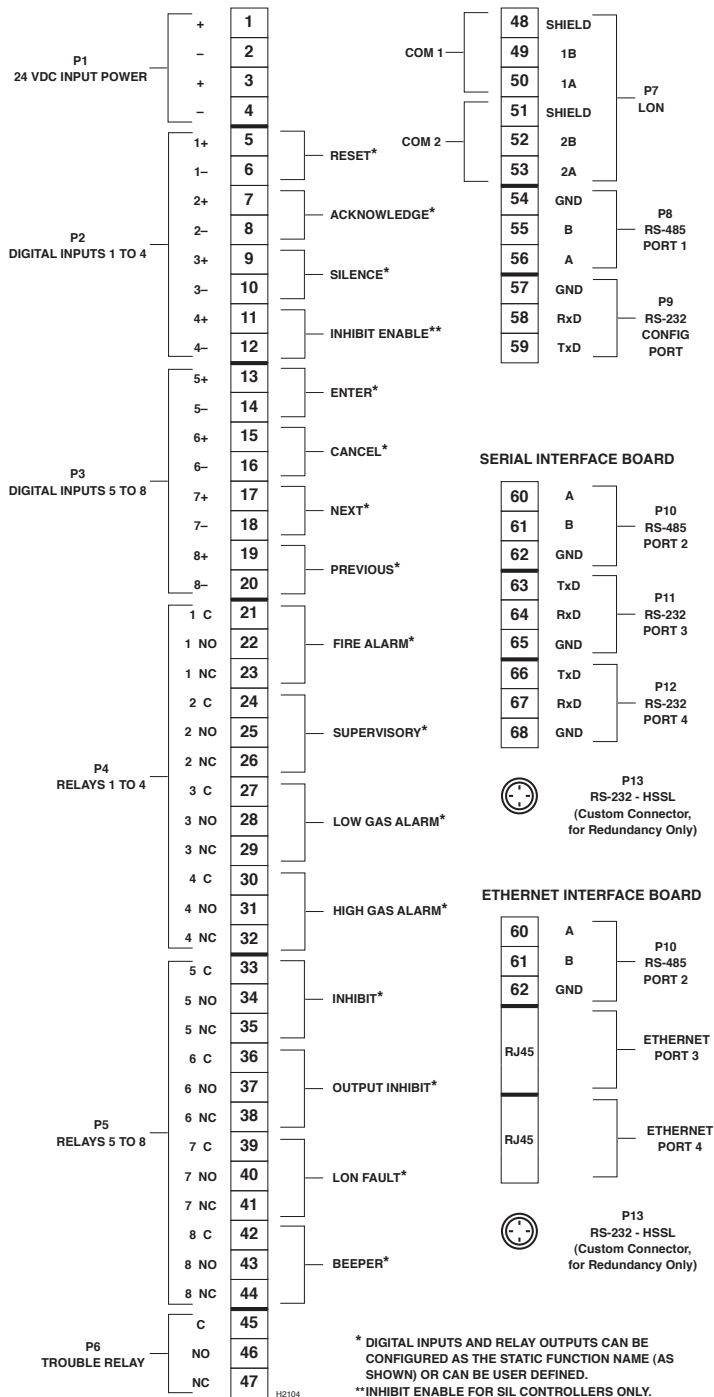

Figure 3-7—EQP Controller Terminal Identification

## Connector P10, Terminals 60, 61 & 62, Port 2 – RS-485 Modbus RTU Master/Slave

Configuration data downloaded into the controller configures the serial interface transmission baud rate, parity check for the serial port, and Modbus device address. Software selectable baud rates are 9600, 19200, 38400, 57600, 115200 and 230400. Software selectable parity is None, Odd, and Even. The controller uses 8 data bits with 1 stop bit.

Port Pinout (3-position terminal block)

- 60 — A
- 61 — B
- 62 — GND

### Serial Interface Board Jumpers

#### Jumper P25 – RS-485 Termination Jumper, Port 2

- 1-2 Terminated 121 ohms (factory setting)
- 2-3 Unterminated  
Transceiver input impedance: 68 kohm

#### Jumper P3 – RS-485 Ground Fault Monitor, Port 2

- 1-2 Enabled
- 2-3 Disabled (factory setting)

### Ethernet Interface Board Jumpers

#### Jumper P6 – RS-485 Termination Jumper, Port 2

- 1-2 Terminated 121 ohms (factory setting)
- 2-3 Unterminated  
Transceiver input impedance: 68 kohm

#### Jumper P5 – RS-485 Ground Fault Monitor, Port 2

- 1-2 Enabled
- 2-3 Disabled (factory setting)

Use Port 2 to pass safety critical information between controllers. Ensure that Ground Fault Monitoring is enabled. User logic can pass all alarm, trouble, and supervisory information between the controllers. Watchdog timers must be implemented in user logic to verify the integrity of the SLC. Consult the local authority having jurisdiction for annunciation requirements.

## CONTROLLER TO CONTROLLER COMMUNICATION

### Controller to Controller Communication (SLC485) with Signaling Line Circuit Classification Class B or X, per NFPA 72®

To connect up to twelve controllers together and be able to transfer safety information between the controllers, the communication link must be classified as a signaling line circuit per NFPA 72®. With the Serial Interface Board, Port 2 (plug 10) is a RS-485 serial connection that is ground fault monitored.

To meet the signaling line circuit (Class B or Class X) requirements, the following must be configured for correct operation:

- All controllers must have the same type Interface Board (Ethernet or Serial) installed.



*When using the Ethernet Interface Board, controllers communicating over P10, Port 2 - RS-485 are required to be located within the same room or be wired in conduit within 20 feet (6 meters) for signalling line transient protection.*

- The Termination jumper P28 must be set to Terminate (position 1-2) on all controllers.
- The Ground Fault Monitor jumper P29 must be set to Enabled (position 1-2) on all controllers.
- For Class X, Connect terminals A (# 56) and B (# 55) between the controllers. Connect terminal A (# 60) and B (# 61) between controllers using a different cable route. Connect GND (# 54) to GND (# 62) on each controller.
- For Class B, connect terminals A (terminal number 60) and B (terminal number 61) between the controllers. The GND (terminal number 62) must not be connected.

See Figure 3-8B and 3-9B for wiring details.

Note 1: 56.7 kbps minimum and 115.2 kbps maximum baud rate required for proper communication.

Note 2: Consult the factory for configuration set-up.

Note 3: Maximum SLC485 length over copper not to exceed 1000 meters.

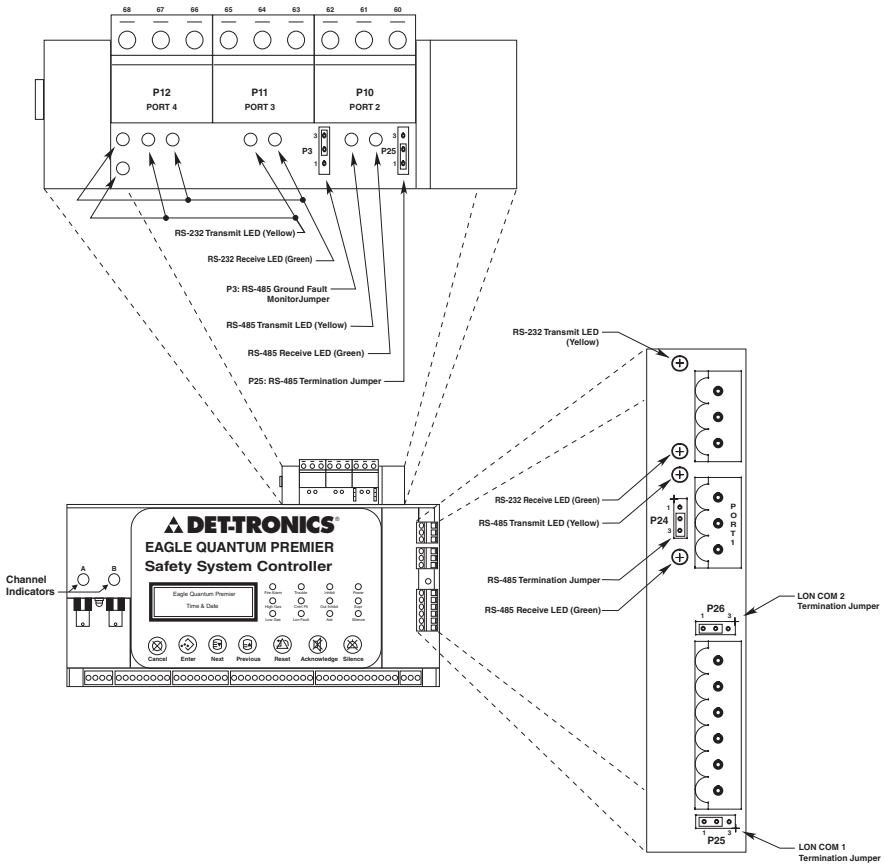

Figure 3-8A—Location of Termination Jumpers, Communication Indicator LEDs, and Communication Ports for Controller with Serial Interface Board

Manufacturer	Model Number	Description
Moxa (www.moxa.com)	TCF-142-S	RS-485 to Single-mode Fiber Optical Converter
Phoenix Contact	PSI-MOS-RS-485W2/FO	RS-485 to Multi-mode Fiber Optical Converter

Table 3-9—Approved Supported Media Converters for Fiber Optical Link

### Controller to Controller with Fiber Optic Link, Signal Line Circuit Classification Class B or X per NFPA 72®.

Up to twelve EQP controllers (single or redundant pair) can be inter-connected via a fiber optic link. This communication link is classified as a signaling line circuit per

NFPA 72® to allow safety information to be transferred between controllers.

The fiber optic link incorporates media converters to convert from copper to fiber optic cable. The converter must be located in the same cabinet as the controller and cannot use ground fault monitoring. The approved supported converters are shown in Table 3-9. The link budget for the listed fiber optic converters is 10dB.



**WARNING**

*The fiber converters must be mounted inside the same enclosure as the controllers to conform to NFPA 72®.*

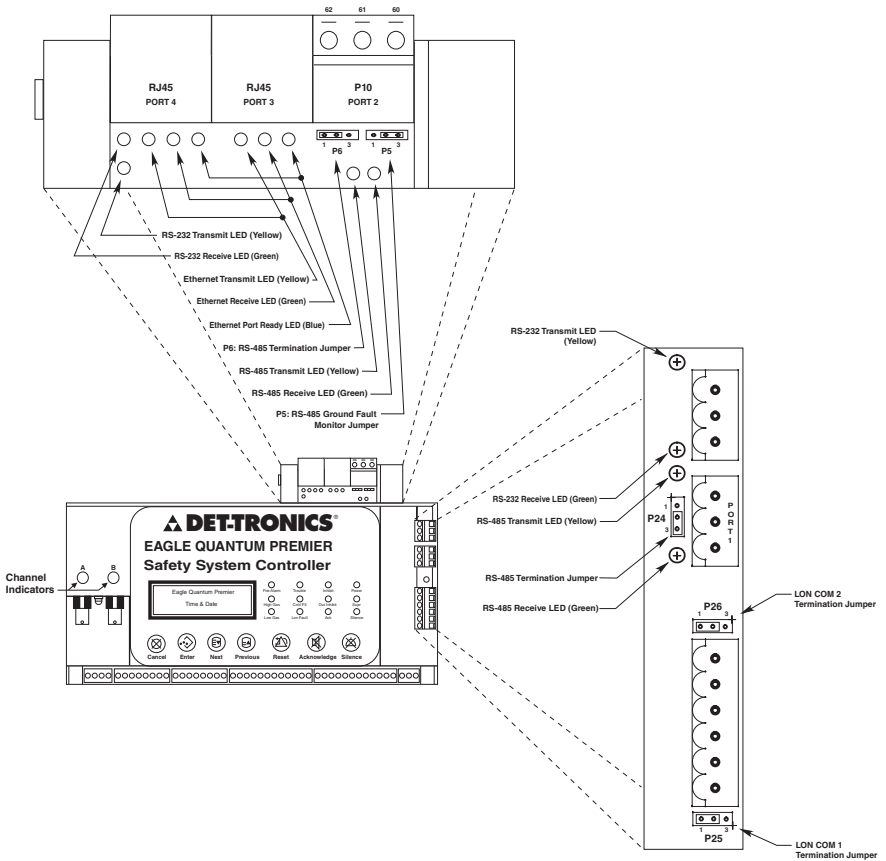

Figure 3-8B—Location of Termination Jumpers, Communication Indicator LEDs, and Communication Ports for Controller with Ethernet Interface Board

The media converter can be connected to either of the EQP controller RS-485 communication ports (Port 1 or Port 2). Figure 3-14 illustrates a typical Class B wiring connection (single mode) between two EQP controllers in a redundant configuration using Port 1. Note: If Port 2 is preferred, the Serial Interface Board must be purchased.

Figure 3-11 shows a typical Class X wiring connection (single mode).

Figure 3-12 shows a typical Class X wiring connection for Phoenix (multi mode).

For more information regarding selection and installation of fiber optic media, please contact Det-Tronics customer service.

**Connector P11, Terminals 63, 64 & 65, Port 3—**

The maximum distance of a particular optic link given the optical budget is calculated as:

$$\text{Fiber Length} = \frac{[\text{Optical budget}] - [\text{Link Loss}]}{[\text{Fiber Loss / km}]}$$

where link loss includes number of end connectors, splices and safety margin.

Example: 10 db link budget  
 Cable Attenuation: 0.4 db / km  
 2 connectors: (1 each end) with 0.5 db ea.  
 Safety margin: 3.0 db max

$$\text{Max. Distance} = \frac{10 - (2 \times 0.5) - 3.0}{0.4} = 15 \text{ km}$$

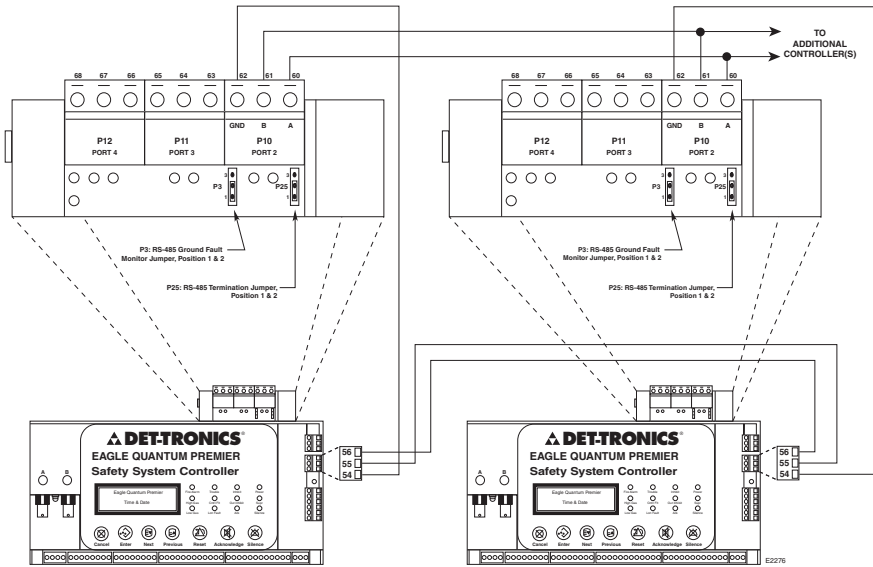

Figure 3-9A—Controller to Controller Communication with Class A Signaling Line Circuit Classification per NFPA 72®, for Controllers with Serial Interface Board

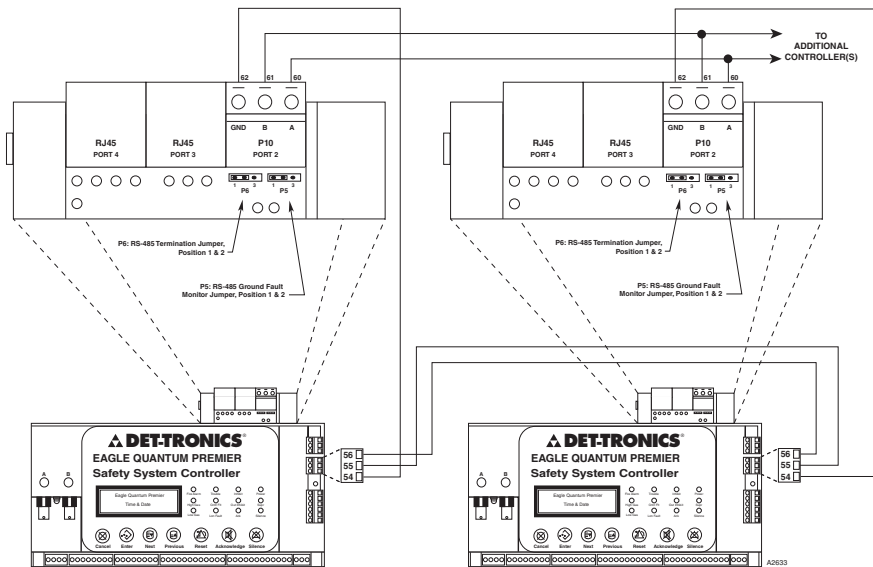

Figure 3-9B—Controller to Controller Communication with Class A Signaling Line Circuit Classification per NFPA 72®, for Controllers with Ethernet Interface Board

**(Serial Interface Board only)**  
**RS-232 Modbus RTU Master/Slave or S<sup>3</sup>**  
**Configuration Port (Non-Isolated)**

Configuration data downloaded into the controller configures the serial interface transmission baud rate, parity check and Modbus device address for the serial port. Software selectable baud rates are 9600, 19200, 38400, 57600, 115200, and 230400. Software selectable parity is None, Odd, and Even. The controller uses 8 data bits with 1 stop bit.

Port Pinout (3-position terminal block)

- 63 — TXD
- 64 — RXD
- 65 — GND

**RJ45, Port 3**  
**(Ethernet Interface Board only)**  
**Ethernet Modbus TCP Client/Server**  
**or S<sup>3</sup> Configuration Port (Non-Isolated)**

Configuration data downloaded into the controller configures the Ethernet interface IP address, subnet mask, gateway, and local port number. This port may be used as a Modbus TCP Client or a Modbus TCP Server. This port may also be used as an alternate S<sup>3</sup> configuration port. EQP controllers come from the factory with the following default values for Port 3:

Port 3	IP Address	192.168.127.251
Port 3	Subnet Mask	255.255.255.000

**NOTE**

*Maximum Modbus update time per port is 250 mSec.*

**Connector P12, Terminals 66, 67 & 68, Port 4—**  
**(Serial Interface Board only)**  
**RS-232 Modbus RTU Master/Slave**  
**(Non-Isolated)**

Configuration data downloaded into the controller configures the serial interface transmission baud rate, parity check and Modbus device address for the serial port. Software selectable baud rates are 9600, 19200, 38400, 57600, 115200, and 230400. Software selectable parity is None, Odd, and Even. The controller uses 8 data bits with 1 stop bit.

Port Pinout (3-position terminal block)

- 66 — TXD
- 67 — RXD
- 68 — GND

**RJ45, Port 4**  
**(Ethernet Interface Board only)**

Ethernet Modbus TCP Client/Server  
 Configuration data downloaded into the controller configures the Ethernet interface IP address, subnet mask, gateway, and local port number. This port may be used as a Modbus TCP Client or a Modbus TCP Server. EQP controllers come from the factory with the following default values for Port 4:

Port 4	IP Address	192.168.127.252
Port 4	Subnet Mask	255.255.255.000

**NOTE**

*Maximum Modbus update time per port is 250 mSec.*

**Connector P13 —**  
**RS-232 High Speed Serial Port**

This port is dedicated to inter-controller connection required for redundancy, and is not available for any other use. This port is automatically configured.

**CONFIGURATION**

**Software Defined Addresses**

Det-Tronics Safety System Software (S<sup>3</sup>) is programmed with the addresses that are assigned to the controller when the configuration file is downloaded into the controller. Addresses define and configure the Controller's LON address, Modbus slave address, ControlNet option board address, and Ethernet DLR option board address. Each device on the LON must be assigned a unique tag number. This tag number must include zone designation, which will be shown on the Controller's display when the device is in alarm.

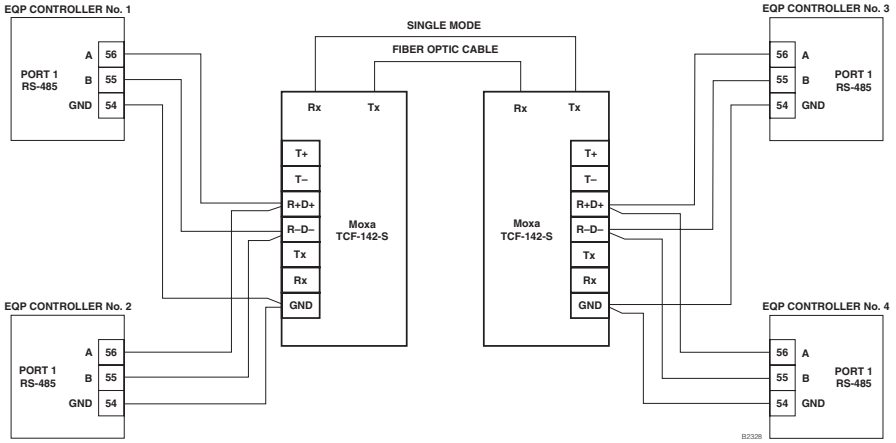

Figure 3-10—Controller to Controller NFPA 72<sup>®</sup> Approved Fiber Optic Link, Class B

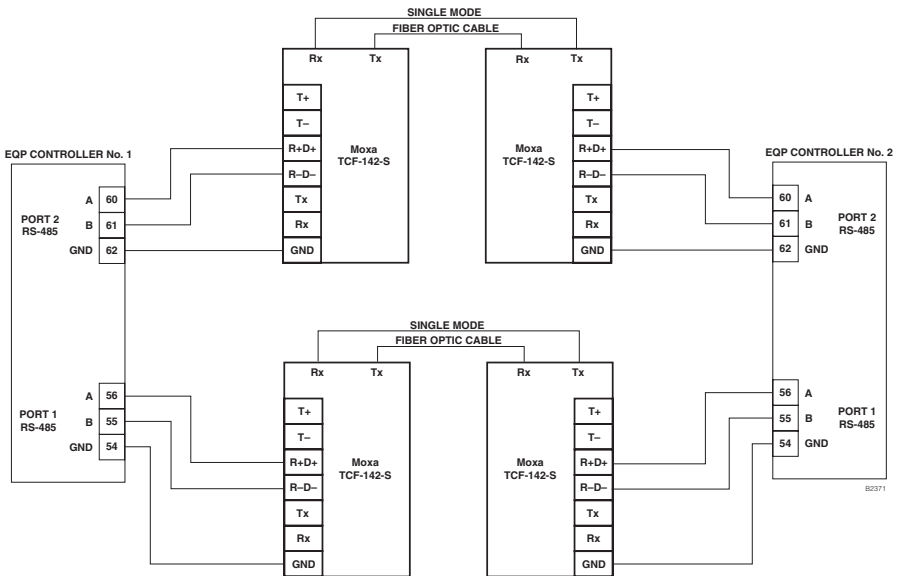

Figure 3-11—Single Mode Controller to Controller NFPA 72<sup>®</sup> Approved Fiber Optic Link, Class X

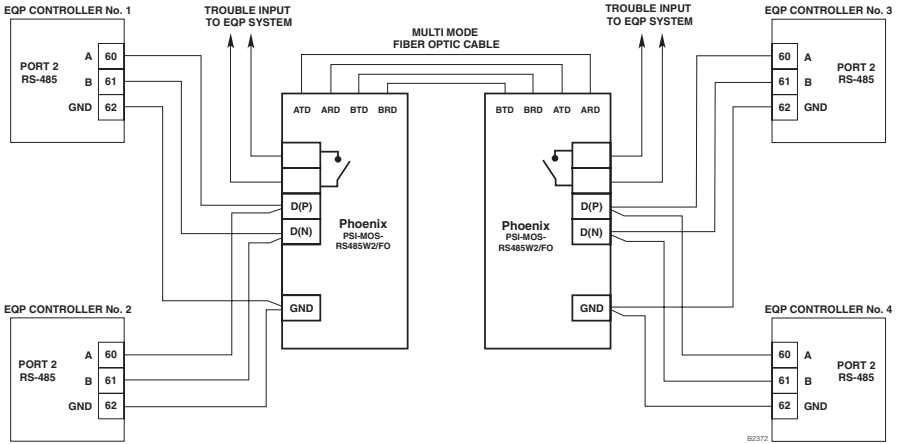

Figure 3-12—Multi-Mode Controller to Controller NFPA 72® Approved Fiber Optic Link, Class X

## EQ3XXX REDUNDANT CONTROLLER INSTALLATION

The redundant controllers must be purchased with the following options for correct installation:

- Either Ethernet or Serial Interface Board
- High-speed serial cable
- LON termination modules (2).

### ENCLOSURE REQUIREMENTS

The redundant controllers must be located next to each other in the same enclosure (4 ft interconnecting cable).

### MOUNTING

The controllers are designed for direct panel mounting or DIN rail mounting. See “Specifications” section of this manual for mounting dimensions.

### WIRING

The redundant controllers are wired the same as a simplex controller except for the LON wiring and the dedicated high-speed serial link, which are defined below. Refer to EQ3XXX Controller Installation for general installation details.

### LON WIRING

The LON must be connected to both redundant controllers to ensure correct operation. Two LON Termination Modules are required for the installation as shown in Figure 3-13.

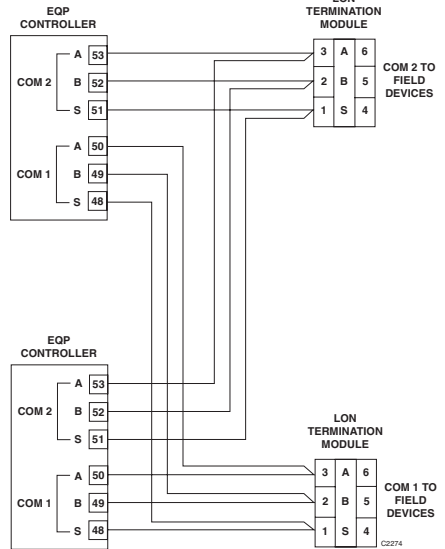

NOTE: LON TERMINATION JUMPERS P25 AND P26 (SEE FIGURE 3-12) MUST BE IN POSITION 2 AND 3 FOR REDUNDANT CONFIGURATION (ON BOTH CONTROLLERS).

Figure 3-13—LON Connection for Redundant EQP Controllers



## HIGH SPEED SERIAL LINK (HSSL)

The redundant controllers are connected together by a dedicated high-speed serial link. This link is a pre-fabricated cable that has a custom connector for ease of use. Redundant controllers are automatically addressed with the HSSL cable. One end of the cable is labeled Primary. The primary controller takes address 1, while the secondary controller is address 2. The significance this has for the user is that the primary is the default master when both controllers are powered-up at the same time.

## CONFIGURATION

### S<sup>3</sup> Configuration

The S<sup>3</sup> configuration software is used to configure the redundant controllers. A check box on the controller configuration screen must be enabled and downloaded to the controllers.

### IMPORTANT

*If the controllers have not been configured for redundancy via the S<sup>3</sup> configuration software, redundancy will not function.*

### Controller Addresses

The LON addresses are pre-determined and cannot be adjusted. Address 1 and 2 have been reserved for a redundant controller configuration.

### RS-485/RS-232 (Port 1 through Port 4)

RS-485/RS-232 ports 1 through 4 on each controller share the serial settings including baud rate and address. Controllers in standby mode don't respond to or issue Modbus RTU messages. This allows for transparent switching on a multi-drop network. If RS-232 is used, a relay switching mechanism can be used.

### ControlNet

The ControlNet interface on each controller will have a different address. This allows both controllers to reside on the same ControlNet network at the same time. The primary controller uses the configured address while the standby assumes an address 1 higher than the primary controller. Application logic in the attached PLC must be used to determine which

controller has the correct output information. Information coming from the PLC should be written to both Premier® Controllers.

### Ethernet DLR

The Ethernet DLR interface on each controller will have a different address. This allows both to reside on the same network at the same time. The primary controller uses the configured address while the standby assumes an address 1 higher than the primary controller. Application logic in the attached PLC must be used to determine which controller has the correct output information. Information coming from the PLC should be written to both Premier® Controllers.

### Ethernet

The Ethernet interface ports on each controller will all have unique IP addresses. This allows both controllers to reside on the same Ethernet network at the same time. The primary and secondary controller IP addresses for ports 3 and 4 are part of the configuration data. During the configuration download, the primary controller assigns the primary IP address to itself and passes the secondary IP address on to the secondary controller. Controllers in standby mode do not respond to Modbus TCP/IP messages. Ethernet applications need to redirect to the alternate IP address when controller switch overs occur.

## EQ21XXPS SERIES POWER SUPPLY AND POWER SUPPLY MONITOR INSTALLATION



**WARNING**

*ALWAYS follow all safety notes and instructions when installing power supply or batteries!*



**WARNING**

*Make sure a.c. power is OFF at main a.c. breaker before beginning power supply installation!*

**IMPORTANT**

*Power supplies require unrestricted air flow for proper cooling.*

## MOUNTING

Mount the power supply monitor in a Nationally Recognized Test Laboratory (NRTL) labeled enclosure. Refer to the "Specifications" section for mounting dimensions.

## WIRING



### CAUTION

*The power supply should be properly connected to an earth ground! A ground wire MUST be connected to the power supply unit's case ground!*

### NOTE

*The Power Supply Monitor uses two of the four DIP switches to select an appropriate fault level for the installation. See Figure 3-16. The unit will fault when the batteries source a current level higher than the threshold for 190 seconds. The fault will clear when the current drops to half the level for 190 seconds. The current level selection is based on the minimum current draw of the attached equipment. The selected value must be less than the actual minimum current draw for the system.*

1. Verify that the input source is the same voltage and frequency as that marked on the nameplate of the power supply.
2. Verify that transformer taps are set for the correct a.c. input. (Input tap setting is located inside the power supply enclosure.)
3. Verify that the supply power wire size and fusing are adequate for the current indicated on the power supply nameplate.

### NOTE

*Consult the power supply manufacturer's instruction manual provided with the support documentation received with the Eagle Quantum System.*

### NOTE

*Required Overload Current is usually equal to 15% of the nominal rating.*

4. Connect external wiring to the appropriate points on Power Supply. Refer to Figure 3-18 for terminal block locations and Figures 3-17 and 3-18 for terminal identification. Connect the 24 Vdc power wires and the LON network cable to the appropriate points on J1. (Redundant "+," "-", and shield terminals are connected internally.) **Do not** ground any shield at the monitor / power distribution cabinet. Insulate the shields to prevent shorting to the device housing or to any other conductor.
5. Connect a two wire cable between the AC input of the power supply and terminals 1 and 4 on J3, the AC input terminal block on the power supply monitor. See Figure 3-18.
6. Connect the "B" terminal on the power supply monitor to the negative (-) side of the backup battery. Connect a correctly sized circuit breaker in the battery circuit as shown in Figure 3-17. The circuit breaker must be rated between 130% and 250% of the total load.
7. Connect the "C" terminal on the power supply monitor to the negative (-) side of the power supply.
8. Wire the power distribution circuit breakers to the output of the power supply. Circuit breaker ratings must be between 130% and 250% of the full load rating.
9. Set the device network address for the power supply monitor.

### NOTE

*For additional information, refer to the power supply manufacturer's instruction manual provided with the support documentation received with the Eagle Quantum Premier® system.*

## STARTUP

Turn on the power supply and allow the voltage to stabilize at 27 volts before closing the circuit to the battery.

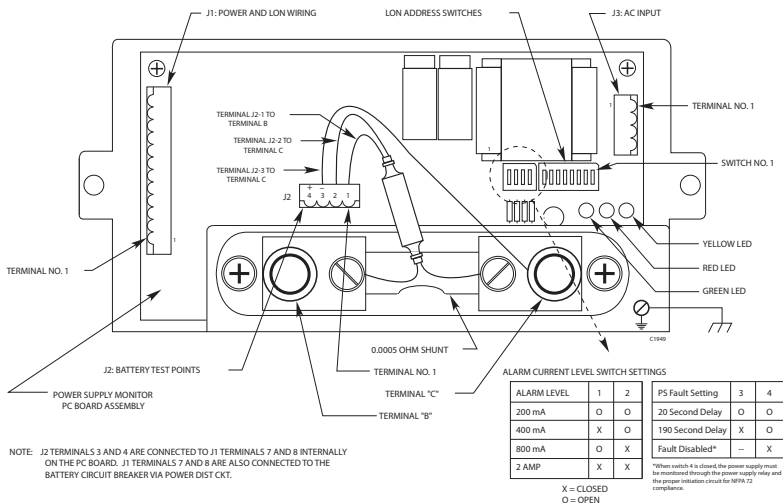

Figure 3-14—Power Supply Monitor Terminal and Switch Location

## MEASURING BATTERY VOLTAGE AND CHARGING CURRENT

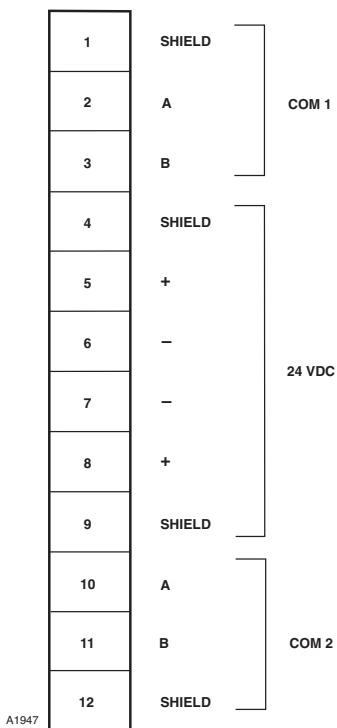

Figure 3-15—J1: Power and LON Wiring Terminal

Measure the battery voltage at terminals 3 and 4 of terminal block J2. See Figure 3-14 and 3-18.

To measure the battery charging current, connect a digital voltmeter to terminals 1 and 2 of terminal block J2. The voltmeter will read 1 millivolt (0.001 volt) for each 2 amperes of current.

Current in Amperes = Meter reading in millivolts x 2

Example: A reading of 50 millivolts indicates a charging current of 100 amperes.

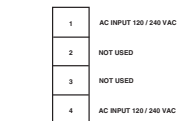
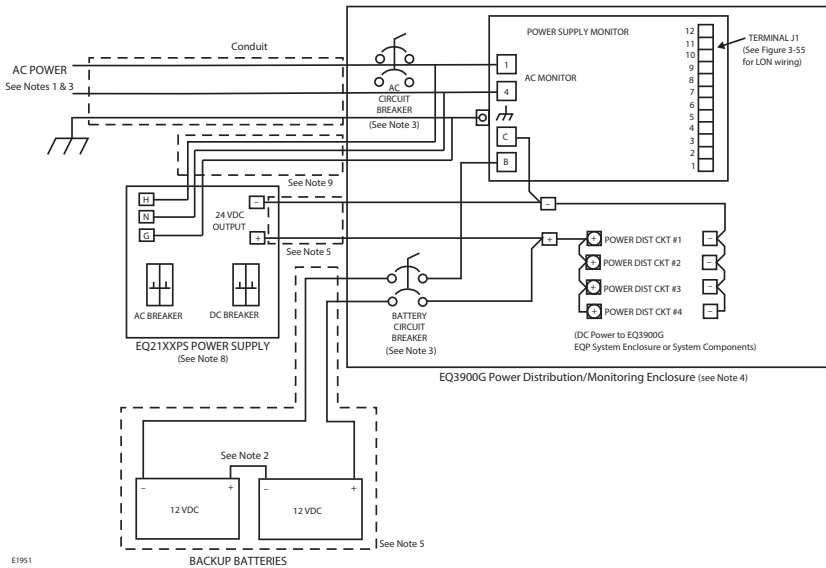

Figure 3-16—J3: AC Input Terminal



E1951

NOTES

1. AC INPUT SELECTABLE (THROUGH THE OIS) FOR 120 / 208 / 240 VAC.
2. BATTERY SIZE CALCULATED BASED ON SYSTEM LOAD.
3. CIRCUIT BREAKER SHALL PROTECT AGAINST EXCESSIVE CURRENT LOAD.
4. NRTL EQ3900G POWER DISTRIBUTION/MONITORING ENCLOSURE IS KEY LOCKED ENCLOSURE.
5. DASH LINES DENOTE PROTECTION AGAINST PHYSICAL DAMAGE.

6. ANY PRIMARY AND SECONDARY POWER SUPPLY UNITS MAY BE INSTALLED EXTERNALLY TO THE NRTL EQ3900G POWER DISTRIBUTION/MONITORING ENCLOSURE, PROVIDED THEY ARE PROTECTED AGAINST PHYSICAL DAMAGE. ALL DEDICATED BRANCH CIRCUITS AND CONNECTIONS BETWEEN PRIMARY AND SECONDARY POWER SUPPLY UNITS AND THE NRTL EQ3900G POWER DISTRIBUTION/MONITORING ENCLOSURE SHALL ALSO BE PROTECTED AGAINST PHYSICAL DAMAGE.
7. SUPERVISION (SINGLE OPENS & GROUNDS) OF THE INTERCONNECTIONS BETWEEN POWER SUPPLY (24 VDC OUTPUT) TO NRTL EQ3900G POWER DISTRIBUTION/MONITORING ENCLOSURE AND BACKUP BATTERIES TO NRTL EQ3900G POWER DISTRIBUTION/MONITORING ENCLOSURE IS PERFORMED BY EQ2100PSM POWER SUPPLY MONITOR.
8. THE CIRCUIT DISCONNECTING MEANS (AC & DC BREAKERS) SHALL BE ACCESSIBLE ONLY TO AUTHORIZED PERSONNEL.
9. AC WIRING CABLE MUST BE  $\leq 20$  FEET IN CONDUIT.

Figure 3-17— Wiring Connections for a Power Supply Monitor, EQ21XXPS Series Power Supply and Backup Batteries

## EQP2XX0PS(-X) POWER SUPPLIES AND REDUNDANCY MODULE INSTALLATION

### WARNING

*ALWAYS follow all safety notes and instructions when installing power supply or module!*

### WARNING

*Make sure a.c. power is OFF at main a.c. breaker before beginning power supply installation!*

### IMPORTANT

*Power supplies require unrestricted air flow for proper cooling.*

## MOUNTING

Mount the power supply and Redundancy Module in a Nationally Recognized Test Laboratory (NRTL) labeled enclosure. Refer to the “Specifications” section for mounting dimensions. Refer to power supply and module manufacturer’s instruction manual provided with support documentation received with the EQP system for additional installation details and instructions.

## WIRING

### CAUTION

*The power supply should be properly connected to an earth ground! A ground wire MUST be connected to the power supply units’s ground terminal!*

1. Connect external wiring to the appropriate points on Power Supplies.

Refer to Figure 3-19A for terminal locations for EQP21X0PS(-X).

Refer to Figure 3-19B for terminal locations for EQP2410PS(-P) Converter.

Refer to Figure 3-19C for terminal locations for EQP2120PS(-X) with EQP2410PS(-P) Converter.

2. Connect the 24 Vdc output to the Redundancy Module. (Redundant “+” and “-” power supply terminals are connected internally.)
3. To ensure compliance with NFPA 72®, primary and secondary power supplies shall be monitored for the presence of voltage at the point of connection to the system. Connect the power supply unit for preferred preventive function monitoring. Refer to Figure 3-20 for an example of power supply relays wired in series for power monitoring.

**NOTE**

*Contacts are closed during normal operation. The circuit shall be wired to an input on the EQP system (EDIO or IDC). In Logic, the selected input must be inverted and used to activate an alarm trigger gate, which initiates a fault message on the Controller and activates the fault relay output.*

*No supervision is necessary, since the EDIO or IDC module must be installed in the same cabinet with EQP21X0PS and EQP2410PS.*

For USCG Approved System monitoring details, refer to Appendix D.

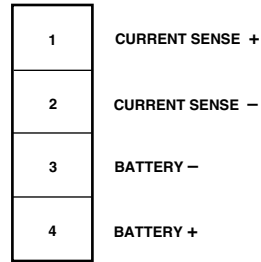

Figure 3-18—J2: Battery Test Points

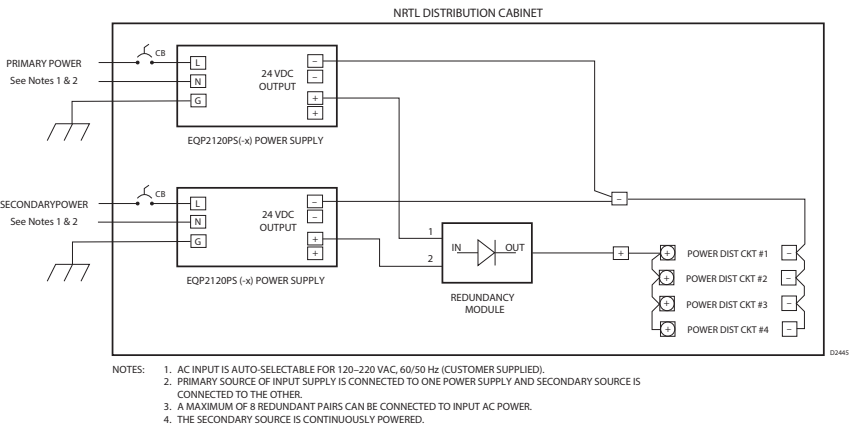

Figure 3-19A—Wiring Connections for a 20 amp DC (Maximum) Power Supply with Primary and Secondary AC Sources

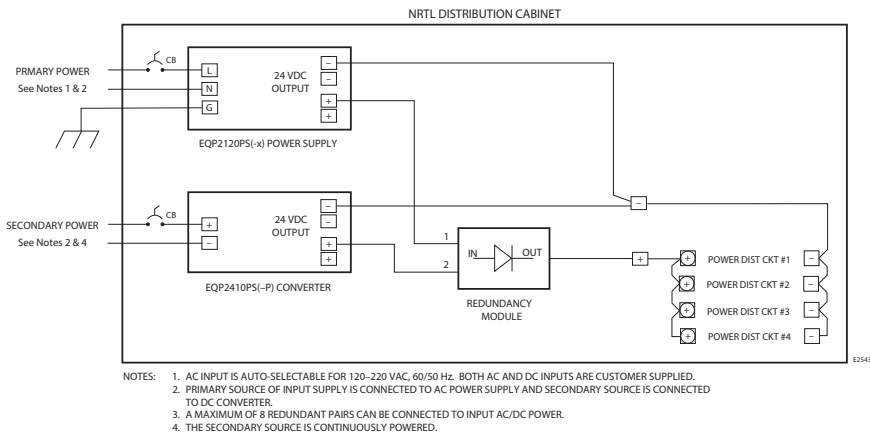

Figure 3-19B—Wiring Connections for a 10amp (Maximum) Power Supply with an AC Primary and DC Secondary Source

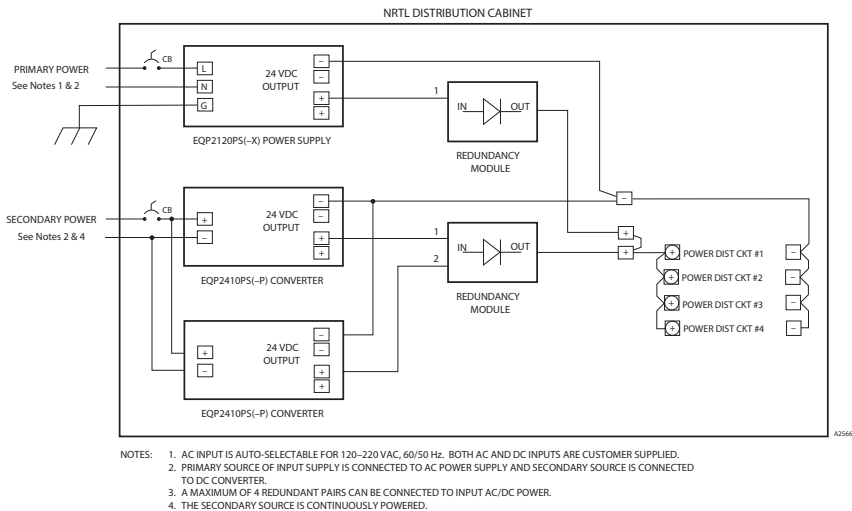

Figure 3-19C—Wiring Connections for a 20amp (Maximum) Power Supply with an AC Primary and DC Secondary Source

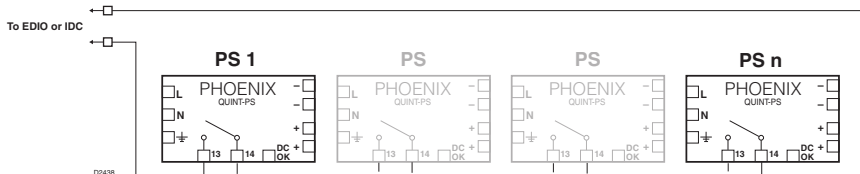

Figure 3-20—Power Supply and Converter Relays Wired in Series for Trouble Monitoring (up to 16 Power Supplies/Converters)

**NOTE**

For additional information, refer to the power supply manufacturer's documents provided with the support documentation received with the Eagle Quantum Premier® system.

**STARTUP**

Turn on the power supply and allow the voltage to stabilize. Verify the output voltage and adjust as needed. Refer to "EQP2XX0PS(-X) Power Supplies" in the Specifications section of this manual.

**IMPORTANT**

The output voltage is adjustable. An even current distribution must be ensured by precisely setting all power supply units that are operated in parallel to the same output voltage  $\pm 10$  mV.

**IMPORTANT**

To ensure symmetrical current distribution it is recommended that all cable connections from all power supply units/diode redundancy modules to the power distribution bus are the same length and have the same cross section.

**ENHANCED DISCRETE INPUT/OUTPUT (EDIO) MODULE INSTALLATION**

All electrical connections are made to the field wiring connectors furnished with the module. Refer to Figure 3-21 for identification of module wiring terminals.

**Connector P1, Terminals 1 to 6  
24 Vdc Power Input**

Connect the module power supply to terminals 1 and 2. If additional terminals are required for powering other devices, these devices should be connected to terminals 4 and 5. Shields are to be connected to terminals 3 and 6 — chassis (earth) ground terminals. Total output current should be limited to 10 amperes.

**Connector P2, Terminals 1 to 6  
LON/SLC Signaling Circuit Terminals**

Be sure to observe polarity when wiring the LON/SLC.

- 1 — "A" side of signaling circuit for COM 1
- 2 — "B" side of signaling circuit for COM 1
- 4 — "A" side of signaling circuit for COM 2
- 5 — "B" side of signaling circuit for COM 2
- 3, 6 — shield connection

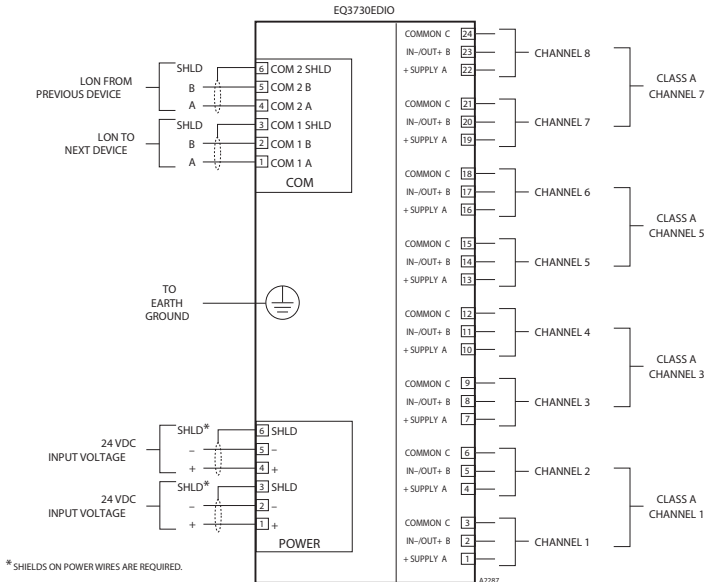

Figure 3-21—EDIO Module Wiring Terminals

**Connector P3, Terminals 1 to 12**  
**Terminals A, B & C**  
**Channels 1 to 4 Input / Output Terminals**

Refer to individual wiring configurations for terminal descriptions. Only channel 1 is shown in each diagram. The information is typical for channels 2-8.

**Connector P4, Terminals 13 to 24**  
**Terminals A, B & C**  
**Channels 5 to 8 Input / Output Terminals**

Refer to individual wiring configurations for terminal descriptions. Only channel 1 is shown in each diagram. The information is typical for channels 2-8.

**Unsupervised Input**

Connect external system wiring to the appropriate terminals on the terminal block. See Figure 3-22.

The input to the EDIO consists of one or more normally open or normally closed switches. An EOL resistor is not required.

Make no connection to “+ Supply” terminal.

**Supervised Input (IDC) Open Circuit Supervision**

Connect external system wiring to the appropriate terminals on the terminal block. For Class B wiring, see Figure 3-23. For Class A wiring, see Figure 3-24. Note that two channels are used for one circuit when using Class A wiring.

The input to the EDIO module consists of one or more normally open switches, with a 10 K ohm, 1/4 watt EOL resistor in parallel across the last switch.

Make no connection to “+ Supply” terminal.

**Supervised Input Open and Short Circuit Supervision**

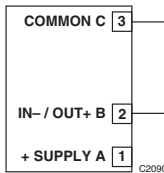

Figure 3-22—Unsupervised Input Configuration

Connect external system wiring to the appropriate terminals on the terminal block. For Class B wiring, see Figure 3-25. For Class A wiring, see Figure 3-27. Note that two channels are used for one circuit when using Class A wiring. Both wiring configurations provide indication of open and short circuit fault.

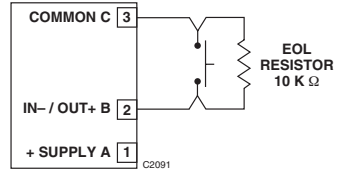

Figure 3-23—Supervised Input Configuration – Class B

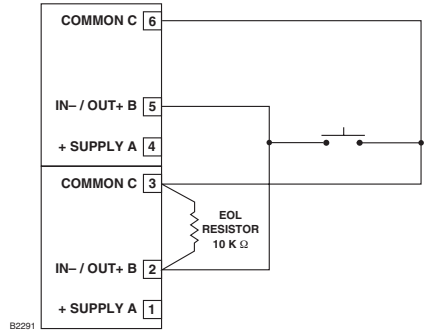

Figure 3-24—Supervised Input Configuration – Class A

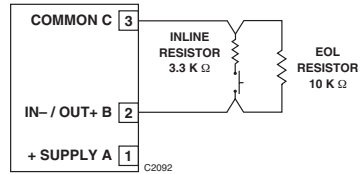

Figure 3-25—Supervised Input Configuration for Opens and Shorts – Class B

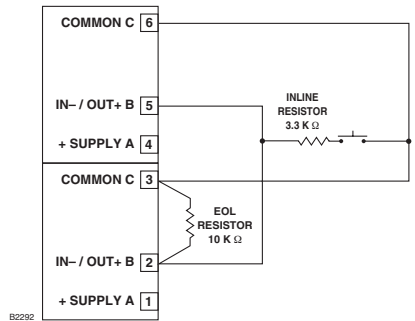

Figure 3-26—Supervised Input Configuration for Opens and Shorts – Class A



The input to the EDIO module consists of normally open switches, with a 10 K ohm, 1/4 watt EOL resistor in parallel across the return channel, and a 3.3 K ohm, 1/4 watt resistor in series with each switch.

**NOTE**

*If using more than one switch, the first active condition (switch closed) must be latched. Any subsequent closed switch will indicate a short circuit fault condition.*

Make no connection to "+ Supply" terminal.

**Input — Deluge and Pre-Action Sprinkler Systems**

The initiating device circuit(s) for use with the deluge and pre-action system configuration must use Class A wiring or be wired within 20 feet and in conduit from the EDIO, as per FM standard 1011/1012/1013.

**Two-Wire Devices**

Figure 3-27 shows the wiring for a 2-wire device connection to an EDIO channel for Class B wiring

**Four-Wire Devices**

Figure 3-28 shows the wiring for a 4-wire device connection to an EDIO channel for Class A wiring



**IMPORTANT**

*No more than 15 devices can be connected per channel.*

**Unsupervised Output**

Connect external system wiring to the appropriate terminals on the terminal block. See Figure 3-29.

No connection should be made to "+ Supply" terminal.

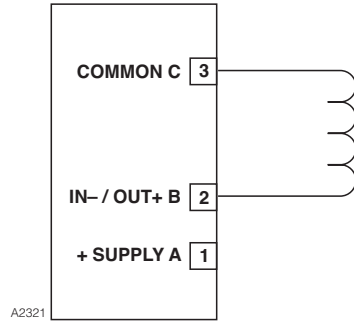

**NOTE: SHUNT/FLYBACK DIODES DO NOT NEED TO BE INSTALLED ON THE FIELD DEVICE. CIRCUIT PROTECTION IS PROVIDED WITHIN THE EDIO MODULE.**

Figure 3-29—Unsupervised Output Configuration

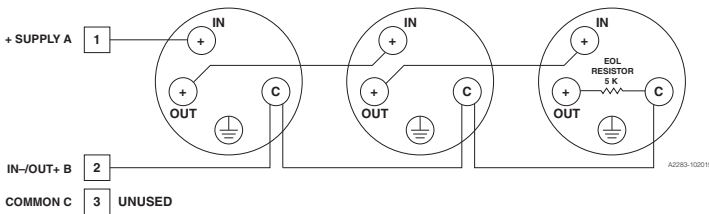

Figure 3-27— 2-Wire Devices (Class B)

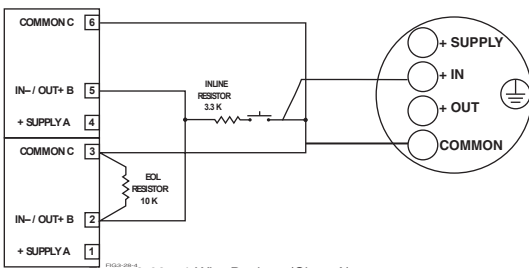

Figure 3-28—4-Wire Devices (Class A)

**Supervised Output—  
Notification Supervised for Open & Short  
Circuits**

Connect external system wiring to the appropriate terminals on the terminal block. For Class B wiring, refer to Figure 3-30.

For Class A wiring, refer to Figure 3-31. Note that two channels are used for one output circuit.

The output of the EDIO module supervises the notification circuit by reversing the polarity of the monitoring circuit. Polarity must be observed when connecting the notification device. It is essential to utilize a notification device approved for fire alarm notification. These devices are polarized and would not require the use of an external diode for the supervision of the circuit. Wire one or more notification devices to the output, with a 10 K ohm, 1/4 watt EOL resistor in parallel across the last device.

No connection should be made to “+ Supply” terminal.

Each output channel is individually activated for response pattern:

- supervisory
- continuous output
- 60 beats per minute
- 20 beats per minute
- temporal
- timed
- trouble.

**Supervised Output—  
Agent Release (Solenoid Circuit)**

Connect external system wiring to the appropriate terminals on the terminal block. For Class B wiring, refer to Figure 3-32.

For Class A wiring, refer to Figure 3-33. Note that two channels are used for one output circuit. Trouble indication is provided for any open wire and the output can still be activated with a single open wire.

No connection should be made to “+ Supply” terminal.

The output of the EDIO module supervises the releasing circuit via the coil of the releasing solenoid. It is essential to utilize a releasing device approved for use with this output

module. This type of output does not require the use of EOL resistors or diodes to supervise the circuit.

The output can be configured for latching, continuous, supervisory, trouble or timed response.

To ensure adequate operating voltage for the output device, the maximum wiring length from the power source to the output device must not exceed the values shown in Table 3-10 for automatic release applications. (For solenoids,

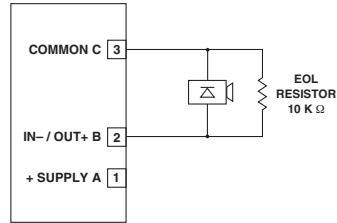

Figure 3-30—Supervised Output Configuration (Notification)— Class B

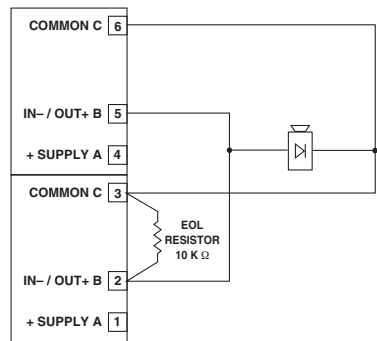
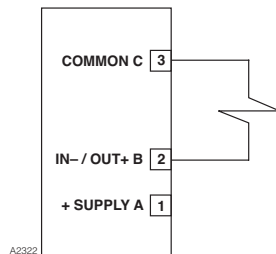

Figure 3-31—Supervised Output Configuration (Notification)— Class A



**NOTE: SHUNT/FLYBACK DIODES DO NOT NEED TO BE INSTALLED ON THE FIELD DEVICE. CIRCUIT PROTECTION IS PROVIDED WITHIN THE EDIO MODULE.**

Figure 3-32—Supervised Output Configuration (Agent Release)

this wire length includes both the wiring from the power supply to the EDIO module and the wiring from the module to the solenoid.)

### Physical Disconnect Switch

In order to comply with NFPA 72 code requirements for releasing service fire alarm systems, a physical disconnect switch must be provided that opens the field wiring between the HSDM Output(s) and the solenoid(s). The switch must be installed with supervised wiring (see Figures 17 and 18)

The physical disconnect switch allows the overall system to be tested without actuating the fire suppression system. The physical disconnect switch also provides a means of completely isolating the solenoids from the HSDM outputs to reduce the likelihood of inadvertent discharge during maintenance activities. As part of the EQP system approval, physical disconnect switch (Det-Tronics part number 000128-191) is approved to be installed within the EQ3900G series of enclosures.

When the physical disconnect switch is operated, an open circuit fault will occur on the affected output channel of the HSDM. The supervisory fault will be announced by the EDIO EQP controller. The open circuit fault is expected and normal under these conditions. The use of a multi-pole switch can provide the physical disconnect function and a signal which can be connected into the EQP system through an Enhanced Discrete Input/Output (EDIO) module so that the use of the disconnect switch can be announced via EQP logic.

Additionally, a signal from the switch can be sent to another input module, such as an EDIO, to indicate that the switch has been used to isolate the solenoids from the HSDM outputs. Please consult the factory for details.

**Please see the Class A and B drawings on pages 3-53, 54.**

### Supervised Output for Deluge and Pre-action Sprinkler Systems

The maximum wiring length must not exceed the values shown in Table 3-10 for deluge and pre-action applications. Per FM Approval requirements, the secondary power must provide capacity for a 90 hour minimum standby operation followed by a minimum of 10 minutes of releasing and alarm operation. The

initiating device circuit(s) for use with the deluge and pre-action system configuration must use Class A wiring or be wired in conduit within 20 feet from the EDIO, as per FM standard 1011/1012/1013.

#### NOTE

*In EQP systems with EQP2120PS(-B) Power Supplies, the secondary power is customer supplied and must be accepted by the Authority Having Jurisdiction (AHJ).*

### CONFIGURATION

#### Setting EDIO Network Address

One unique network address must be assigned to each EDIO module. The address is set by the 8 switch DIP assembly on the EDIO module.

When using the switches located on the EDIO module, the address is binary coded and is the sum of all switches placed in the "closed" position.

Each discrete point of an EDIO module has a tag number and a descriptor for unique identification. A tag number must include zone designation, which will be shown on the controller's display when the point is in alarm.

Det-Tronics S<sup>3</sup> Safety System Software is used for device configuration. The following shows the minimum software/firmware releases:

Controller Firmware		S <sup>3</sup>
Revision	Version	Version
B	4.28	3.1.0.0

Figure 3-33—Supervised Output Configuration (Agent Release)— Class A Wiring

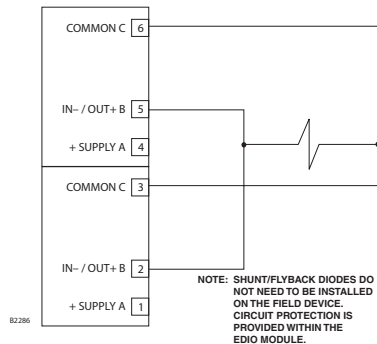

Table 3-10—Typical Maximum Wire Length for FM Approved Solenoids for Deluge and Pre-Action Applications

I <sub>sol</sub> Table 3-10		
Manufacturer	PN	I <sub>sol</sub> (mAdc) @ 20.4 Vdc
Parker (Viking)	11591 NC	365
Parker (Viking)	11592 NC	365
Parker (Viking)	71395SN2ENJ1NOH111C2	340
Parker (Viking)	73218BN4UNLVNOC111C2	320
Parker (Viking)	73212BN4TNLVNOC322C2	600
Parker (Viking)	73212BN4TN00N0C111C2	330
ASCO RedHat	R8210A107	525
ASCO RedHat	8210A107	555
ASCO RedHat	8210G207	365
Viking PN	11601	325
ASCO RedHat Cat#	HV2740607 N.C.	
Viking PN	11602	310
ASCO RedHat Cat #	HV274608 N.C.	
Kidde-Fenwal	897494	130
Cat #	202-749-260563	
Kidde-Fenwal	895630	1500
Cat #	81-895630-000	
Kidde-Fenwal	890181	1500
Det-Tronics PN	00219-209	
Ansul	570537	200
Macron	304.209.001	

\*Note: Alternate secondary power source when accept by Local AHJ, may increase permissible wire voltage drops. Actual secondary voltage must be determined. Voltage and current at solenoid must be known and used in the equation.



The following is based on EQ21xxPS (Primary Source) and Battery (Secondary Source)

Total wire voltage drop = 1.2 Vdc (MAX) = VL<sub>a</sub> + VL<sub>b</sub> \*

VL<sub>a</sub> = I<sub>EDIO</sub> × RL<sub>a</sub>      I<sub>EDIO</sub> = Total current of EDIO and all active outputs

VL<sub>b</sub> = I<sub>sol</sub> × RL<sub>b</sub>      I<sub>sol</sub> see Table 3-10

RL<sub>a</sub> & RL<sub>b</sub> = wire resistance = Ω per foot × 2 (x2 = B+ & B- wires)

Figure 3-34—Calculation for Field Wiring Distance Requirements for Solenoids

## 8 CHANNEL DISCRETE INPUT/OUTPUT (DCIO) MODULE INSTALLATION

The following paragraphs describe how to properly install and configure the 8 Channel DCIO Module.

### MOUNTING

The DCIO must be properly installed in a suitable enclosure that is rated for the location. The enclosure must provide space to install and

wire the DCIO module and must also provide for ground wire termination. Access into the enclosure is gained by using a special tool to open the enclosure. The enclosure should be rated for the temperature range of the location plus the temperature rise of all equipment installed inside the enclosure. The enclosure must be rated for electrical equipment that is going to be installed.

The DCIO can be panel or DIN rail mounted.

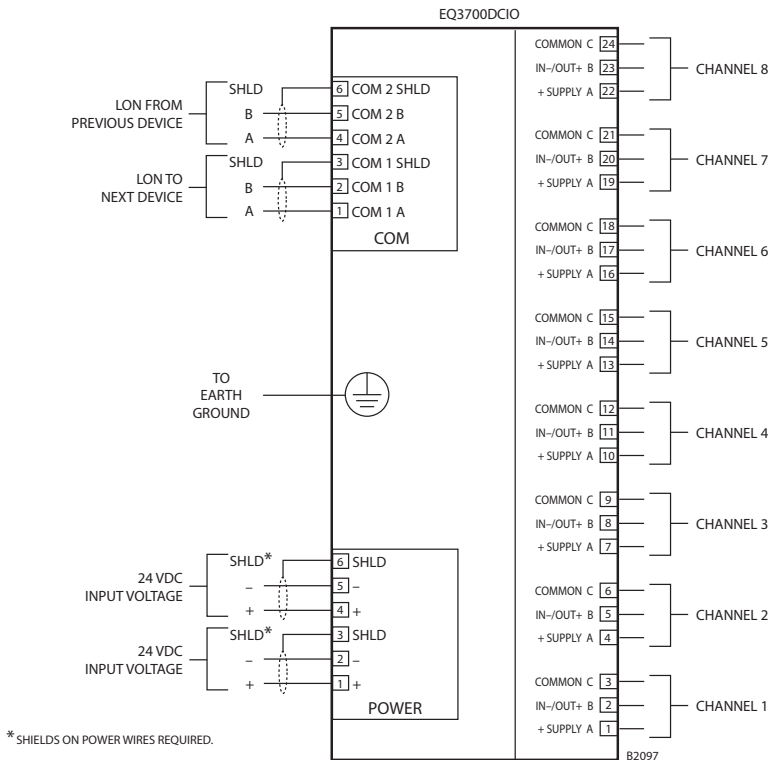

Figure 3-35—DCIO Module Wiring Terminal Configuration

### NOTE

*It is recommended to maintain a minimum of four inches clearance between the module and other equipment to provide adequate room for wiring and ventilation.*

### WIRING

All electrical connections are made to the field wiring connectors furnished with the module.

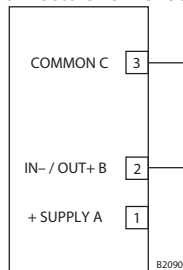

Figure 3-36—Unsupervised Input Configuration

See Figure 3-35 for terminal identification.

### Power Connector, Terminals 1 to 6 24 Vdc Power Input

Power connections to the DCIO depend upon the total current consumption of all the channels in the device. Each output-configured channel can consume up to 2 amperes. Total output current should be limited to 10 amperes.

Connect the power supply to terminals 1 and 2 or to terminals 4 and 5. Power wire shielding should be connected to terminals 3 and 6.

1 — +

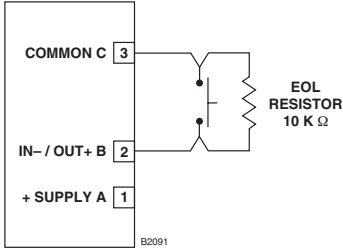

Figure 3-37—Supervised Input Configuration

2 — -  
 3 — Shield\*  
 4 — +  
 5 — -  
 6 — Shield\*

\*Shields on power wires are required.

Connect the module power supply to terminals 1 and 2. If additional terminals are required for powering other devices, these devices should be connected to terminals 4 and 5. Shields are to be connected to terminals 3 and 6.

### COM Connector, Terminals 1 to 6 LON Terminals

Be sure to observe polarity when wiring the LON.

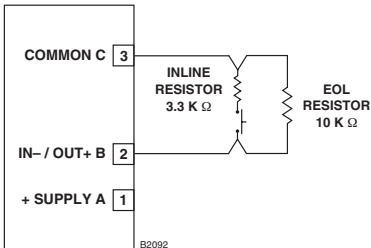

Figure 3-38—Supervised Input Configuration (Opens and Shorts)

1 — "A" side of signaling circuit for COM 1  
 2 — "B" side of signaling circuit for COM 1  
 4 — "A" side of signaling circuit for COM 2  
 5 — "B" side of signaling circuit for COM 2  
 3 & 6 — shield connections.

### Channel Connectors, Terminals 1 to 24 Terminals A, B & C Channels 1 to 8 Input / Output Terminals

Refer to individual wiring configurations for terminal descriptions. Only channel 1 is shown in each diagram. The information is typical for channels 2-8.

### Unsupervised Input

Connect external system wiring to the appropriate terminals. See Figure 3-36.

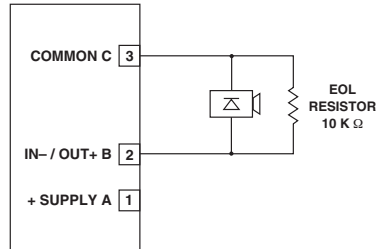

Figure 3-39—Supervised Output Configuration (Notification)

Input to the DCIO consists of one or more normally open or normally closed switches.

#### NOTE

*An EOL resistor is not required.*

#### NOTE

*No connection should be made to the "+ Supply" terminal.*

### Supervised Input (IDC) Open Circuit Supervision Class B

Connect external system wiring to the appropriate terminals on the DCIO terminal block. See Figure 3-37.

The input to the DCIO module consists of one or more normally open switches, with a 10K ohm, 1/4 watt EOL resistor in parallel across the last switch.

#### NOTE

*No connection should be made to the "+ Supply" terminal.*

### Supervised Input (IDCSC) Open and Short Circuit Supervision (Three state – open, switch closure, and short) Class B

Connect external wiring to the appropriate terminals on the DCIO terminal block. See Figure 3-38. Indication of short circuit fault is provided.

The input to the DCIO module consists of a normally open switch, with a 10 K ohm, 1/4 watt EOL resistor in parallel across the switch, and a 3.3 K ohm, 1/4 watt resistor in series with the switch.

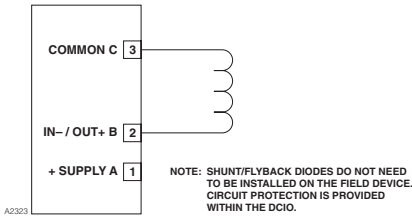

Figure 3-40—Supervised Output Configuration (Automatic Release)

#### NOTE

*No connection should be made to the “+ Supply” terminal. For correct operation, only one input switch can be used per channel.*

### Supervised Output Notification (Horns and Strobes) Supervised Outputs for Open & Short Circuits Class B

Connect external wiring to the appropriate terminals on the DCIO terminal block. See Figure 3-39.

#### NOTE

*Polarity MUST be observed when connecting the notification device.*

It is critical to use a notification device approved for fire alarm notification. These devices are polarized and do not require the use of an external diode for the supervision of the circuit. Wire one or more notification devices to the output, with a 10 K ohm, 1/4 watt EOL resistor in parallel across the last device.

#### NOTE

*No connection should be made to the “+ Supply” terminal.*

Each output channel is individually activated for response pattern:

- continuous output
- 60 beats per minute
- 120 beats per minute
- temporal
- supervisory
- timed
- trouble.

### Supervised Output for Automatic Release Supervised Output for Open Circuits

Connect external wiring to the appropriate terminals on the DCIO terminal block. See Figure 3-40.

Wire one or more releasing devices to the module output.

#### NOTE

*Make no connection to the “+ Supply” terminal.*

The output of the DCIO module supervises the releasing circuit via the coil of the releasing solenoid. It is essential to use a releasing device approved for use with this output module.

#### NOTE

*This type of output does not require the use of EOL resistors or diodes to supervise the circuit.*

The output can be configured for latching, continuous or timed response.

To ensure proper operating voltage, the maximum wiring length from the power source to the DCIO module must not exceed the values shown in Table 3-10 for automatic release applications.

#### NOTE

*For solenoids, this wire length includes both the wiring from the power supply to the DCIO module and the wiring from the module to the solenoid.*

### Supervised Output for Deluge and Pre-action

Connect external wiring to the appropriate terminals on the DCIO terminal block. See Figure 3-40.

The output of the DCIO module supervises the releasing circuit via the coil of the releasing solenoid. It is essential to use a releasing device approved for use with this output module.

### NOTE

This type of output does not require the use of EOL resistors or diodes to supervise the circuit.

### NOTE

For new or retrofit installations, any manufacturer's non-water based agent release valves can be wired into the outputs of the DCIO modules as long as the devices utilize 24 Vdc and do not exceed 2 amperes current draw.

### NOTE

For FM system approval listing, pre-action and deluge applications require that only FM approved deluge valves can be wired into the EDIO or DCIO modules. Table 3-10 lists the supported

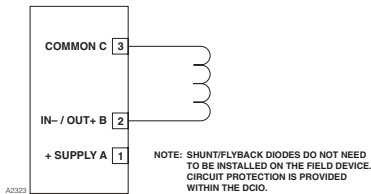

Figure 3-41—Unsupervised Output Configuration

*solenoid groups. Remember that the valves must utilize 24 Vdc and must not exceed 2 amperes current draw.*

The output can be configured for latching, continuous or timed response.

The maximum wiring length must not exceed the values shown in Table 3-10 for deluge and pre-action applications. Per FM Approval requirements, the secondary power must provide capacity for a 90 hour minimum standby operation followed by a minimum of 10 minutes of releasing and alarm operation.

**For initiating device circuit(s) for use with the deluge and pre-action system configuration, an Enhanced Discrete Input/Output Module (EDIO) must be used.**

### NOTE

*In EQP systems with EQP2120PS(-B) Power Supplies, the secondary power is customer supplied and must be accepted by the Authority Having Jurisdiction (AHJ).*

## Unsupervised Output Ancillary Applications (Unrelated to Fire Detection/Protection)

Connect external wiring to the appropriate terminals on the DCIO terminal block. See Figure 3-41.

### NOTE

*No connection should be made to the "+ Supply" terminal.*

## CONFIGURATION

### Setting DCIO Network Address

One unique network address must be assigned to each DCIO module. The address is set by the 8 switch DIP assembly on the DCIO module. The address is binary coded and is the sum of all switches placed in the "closed" position.

Each discrete point of a DCIO module has a tag number and a descriptor for unique identification. A tag number must include zone designation, which will be shown on the controller's display when the point is in alarm.

Det-Tronics S<sup>3</sup> Safety System Software is used for device configuration. The following shows the minimum software/firmware releases:

Controller Firmware		S <sup>3</sup>
Revision	Version	Version
A	1.03	2.0.2.0

## 8 CHANNEL RELAY MODULE INSTALLATION

The following paragraphs describe how to properly install and configure the 8 Channel Relay Module.

### MOUNTING

The Relay Module must be properly installed in a suitable enclosure that is rated for the location. The enclosure must provide space to install and wire the relay module and must also provide for ground wire termination. Access into the enclosure is gained by using a special tool to open the enclosure. The enclosure should be rated for the temperature range of the location plus the temperature rise of all equipment installed inside the enclosure. The enclosure must be rated for electrical equipment that is going to be installed. The device can be panel or DIN rail mounted.



**NOTE**

*It is recommended to maintain a minimum of four inches clearance between the module and other equipment to provide adequate room for wiring and ventilation.*

**WIRING**

All electrical connections are made to the field wiring connectors furnished with the module. See Figure 3-42 for terminal identification.

**Power Connector, Terminals 1 to 6  
24 Vdc Power Input**

- 1 — +
- 2 — -
- 3 — Shield\*
- 4 — +
- 5 — -
- 6 — Shield\*

\*Shields on power wires required.

Connect the module power supply to terminals 1 and 2. If additional terminals are required for powering other devices, these devices should be connected to terminals 4 and 5. Shields are

to be connected to terminals 3 and 6.

**COM Connector, Terminals 1 to 6  
LON Terminals**

Be sure to observe polarity when wiring the LON.

- 1 — "A" side of signaling circuit for COM 1
- 2 — "B" side of signaling circuit for COM 1
- 4 — "A" side of signaling circuit for COM 2
- 5 — "B" side of signaling circuit for COM 2
- 3 & 6 — shield connections.

**Channel Connectors, Terminals 1 to 24  
Unsupervised Output Ancillary Applications  
(Unrelated to Fire Detection/Protection)**

Connect external wiring to the appropriate terminals on the relay module terminal block. See Figure 3-42.

**CONFIGURATION**

**Setting Relay Module Network Address**

One unique network address must be assigned to each relay module. The address is set by the 8 switch DIP assembly on the relay module. The address is binary coded and is the sum of all switches placed in the "closed" position.

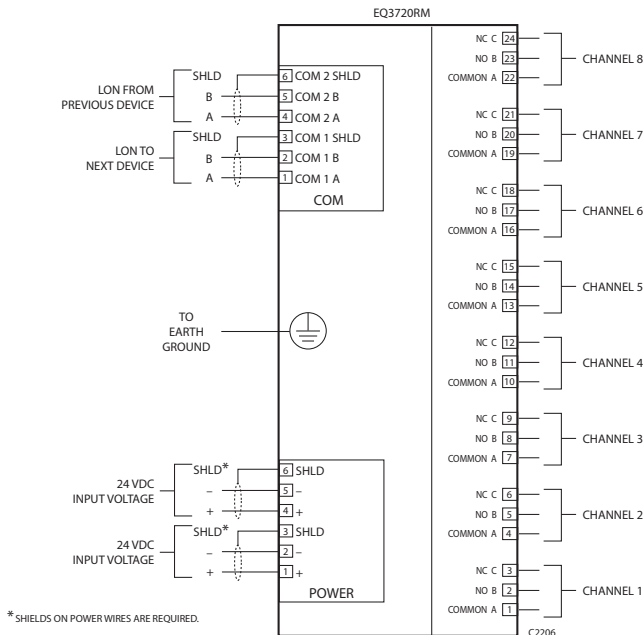

NOTE: RELAY CONTACTS SHOWN IN REST (DE-ENERGIZED) STATE.

Figure 3-42— Relay Module Wiring Terminal Configuration

Each discrete point of a relay module has a tag number and a descriptor for unique identification.

Det-Tronics S<sup>3</sup> Safety System Software is used for device configuration. The following shows the minimum software/firmware releases:

Controller Firmware		S <sup>3</sup>
Revision	Version	Version
A	2.01	2.0.8.0

## ANALOG INPUT MODULE INSTALLATION MOUNTING

The Analog Input Module must be properly installed in a suitable enclosure that is rated for the location. The enclosure must provide space to install and wire the device and must also provide for ground wire termination. Access into the enclosure must be gained by using a special tool to open the enclosure.

The enclosure should be rated for the temperature range of the location plus the temperature rise of all equipment installed inside the enclosure. The enclosure must be rated for electrical equipment that is going to be installed.

### NOTE

*It is recommended to maintain a minimum of four inches clearance between the module and other equipment to provide adequate room for wiring and ventilation.*

### WIRING

All electrical connections are made to the field wiring connectors furnished with the module. (Connectors accept up to 12 AWG wire.) Refer to Figure 3-43 for identification of module wiring terminals.

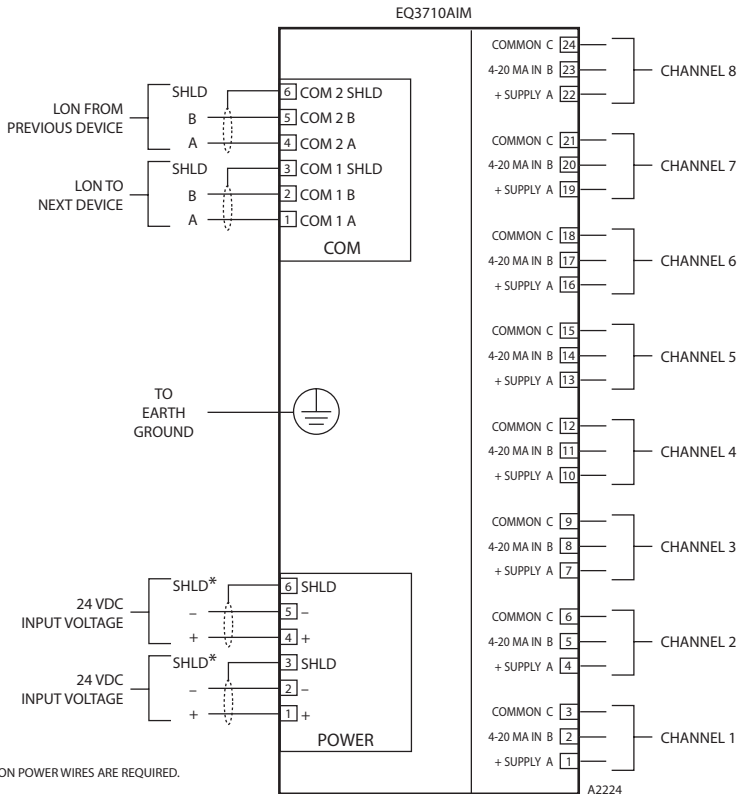

Figure 3-43—Analog Input Module Wiring Terminal Configuration

## Power Connector — Terminals 1 to 6 24 Vdc Power Input

- 1 — +
- 2 — -
- 3 — Shield\*
- 4 — +
- 5 — -
- 6 — Shield\*

\*Shields on power wires are required.

Connect the module power supply to terminals 1 and 2. If additional terminals are required for powering other devices, these devices should be connected to terminals 4 and 5. Shields are to be connected to terminals 3 and 6.

## COM Connector — Terminals 1 to 6 LON Terminals

Be sure to observe polarity when wiring the LON.

- 1 — "A" side of signaling circuit for COM 1
- 2 — "B" side of signaling circuit for COM 1
- 4 — "A" side of signaling circuit for COM 2
- 5 — "B" side of signaling circuit for COM 2
- 3 & 6 — shield connections (shields required).

## Channel Connectors — Terminals 1 to 24 4-20 mA Input Devices

Connect external wiring to the appropriate terminals on the analog input module terminal block. See Figure 3-44 for an example of a 2-wire input. See Figure 3-45 for a 2-wire input with HART interface module. See Figure 3-46 for a 3-wire input, where the transmitter must source a 4-20 mA signal. See Figure 3-47 for a 3-wire input with HART interface module.

Only channel 1 is shown in each diagram. The information is typical for channels 2-8.

## Analog Input Module Channels used as NFPA 72® Approved 4-20 mA Flame Detector Input

Configure the High Alarm setpoint at 19 mA via the S<sup>3</sup> configuration screen, and use the High Alarm to trigger the Fire Alarm in S<sup>1</sup> logic. The AIM sends an exception message for the High Alarm so there is no delay in transmitting the Fire Alarm.

Fault indications and other status information must be decoded in logic from the analog process variable. A five second delay should be used to avoid indicating an incorrect status condition while the analog value is changing between two values.

Table 3-11—

Analog Values (in mA) for Fault and Status Indications when the AIM is Used as a 4-20 mA Flame Detector Input

Status	X3301/2	X5200	X9800	X2200
Fault	0-3.5	0-3.5	0-3.5	0-3.5
IR Pre-Alarm		7.0-9.0		
UV Alarm		11.0-12.99		
IR Alarm		13.0-14.99		
Pre-Alarm		15.0-16.99	15.0-16.99	15.0-16.99

See Table 3-11.

## CONFIGURATION

### Setting Analog Input Module Network Address

One unique network address must be assigned to each analog input module. The address is set by the 8 switch DIP assembly on the analog input module.

When using the switches located on the analog input module, the address is binary coded and is the sum of all switches placed in the "closed" position.

Each point of an analog input module has a tag number and a descriptor for unique identification. A tag number must include zone designation, which will be shown on the controller's display when the point is in alarm.

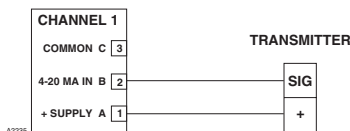

Figure 3-44—Two-Wire Transmitter — Non-Isolated 4 to 20 mA Current Output (Sourcing)

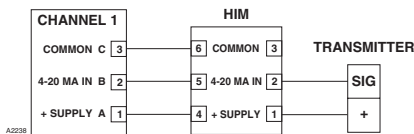

Figure 3-45—Two-Wire Transmitter with HART Interface Module — Non-Isolated 4 to 20 mA Current Output (Sourcing)

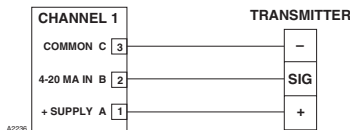

Figure 3-46—Three-Wire Transmitter — Non-Isolated 4 to 20 mA Current Output (Sourcing)

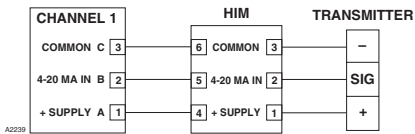

Figure 3-47—Three-Wire Transmitter with HART Interface Module — Non-Isolated 4 to 20 mA Current Output (Sourcing)

Det-Tronics S<sup>3</sup> Safety System Software is used for device configuration. The following tables show the minimum software/firmware releases:

#### For Gas Applications

Controller Firmware*		AIM		S <sup>3</sup>
Rev.	Version	Rev.	Version	Version
B	3.06	B	1.02	2.9.1.1

\*for part number 007606-002

#### For Flame Applications

Controller Firmware*		AIM		S <sup>3</sup>
Rev.	Version	Rev.	Version	Version
C	5.52	D	1.07	4.0.0.0

\*for part number 008983-001

## GAS DETECTOR LOCATION AND INSTALLATION

Gas detection devices must be properly located to provide maximum protection. Determining the proper number of devices and placement varies depending on the specific requirements of the area of protection.

The following should be considered when locating a gas detection device:

1. Gas type. If it is lighter than air (acetylene, hydrogen, methane, etc.), place the sensor above the potential source. Place the sensor close to the floor for gases that are heavier than air (benzene, butane, butylene, propane, hexane, pentane, etc.) or for vapors resulting from flammable liquid spills.

#### NOTE

*Air currents can cause a gas that is heavier than air to rise. Also, if the gas is hotter than ambient air, it could also rise.*

2. How rapidly will the gas diffuse into the air? Select a location for the sensor as close as possible to the anticipated source of a gas leak.

3. Ventilation characteristics. Air movement will cause gas to accumulate more heavily in one area than another. The devices should be placed in areas where the most concentrated accumulation of gas is anticipated.

4. Devices should be pointed down to prevent the buildup of moisture or contaminants on the filter.

5. Devices must be accessible for testing and calibration.

#### NOTE

*The use of the Sensor Separation Kit will be required in some installations.*

## ENVIRONMENTS AND SUBSTANCES THAT AFFECT GAS DETECTOR PERFORMANCE

Catalytic sensors should be located where they are safe from potential sources of contamination that can cause a decrease in the sensitivity of the device including:

- A. Substances that can clog the pores of the flame arrestor and reduce the gas diffusion rate to the sensor including:

Dirt and oil, corrosive substances such as Cl<sub>2</sub> (Chlorine) or HCl, paint overspray, or residue from cleaning solutions that can clog the flame arrestor.

#### NOTE

*A dust cover should be installed to protect the flame arrestor whenever these conditions exist.*

- B. Substances that cover or tie up the active sites on the catalytic surface of the active sensing element such as volatile metal organics, gases, or vapors of hydrides, and volatile compounds containing phosphorous, boron, silicone, etc.

#### Examples:

RTV silicone sealants  
Silicone oils and greases  
Tetraethyl lead  
Phosphine  
Diborane  
Silane  
Trimethyl chlorosilane  
Hydrogen fluoride  
Boron trifluoride  
Phosphate esters

C. Materials that remove the catalytic metals from the active element of the sensor. Some substances react with the catalytic metal forming a volatile compound that can erode the metal from the surface of the sensor's active element.

Halogens and compounds containing halogen are materials of this nature and others include:

**Examples:**

- Chlorine
- Bromine
- Iodine
- Hydrogen Chloride, Bromide or Iodide
- Organic halides:
  - Trichloroethylene
  - Dichlorobenzene
  - Vinyl chloride
  - Freons
  - Halon 1301 (Bromotrifluoromethane).

**NOTE**

*Brief exposure to these materials can temporarily increase sensor sensitivity due to the surface of the active element being etched. Prolonged exposure continues this process until the sensitivity of the sensor is degraded, resulting in shortened sensor life.*

D. Exposure to high concentrations of combustible gases for extended periods of time can stress the sensing element and seriously affect its performance.

The degree of damage to the sensor is determined by a combination of contaminant type, contaminant concentration in the atmosphere, and the length of time the sensor is exposed.

**NOTE**

*If a sensor has been exposed to a contaminant or a high level of combustible gas, it should be calibrated at the time of exposure. An additional calibration a few days later should be performed to determine whether a significant shift in sensitivity has occurred. If necessary, sensor should be replaced.*

**NOTE**

*A combination of accessories such as rain shields and dust covers is not recommended and can result in slow response to a gas leak.*

**EQ22XXDCU DIGITAL COMMUNICATION UNIT USED WITH DET-TRONICS H2S/O2 SENSORS OR OTHER TWO-WIRE 4-20 MA DEVICES**

Determine the best mounting locations for the detectors. Whenever practical, detectors should be placed where they are easily accessible for calibration.



**WARNING**

*Do not apply power to the system with the cover removed unless the area has been verified to be free of combustible gases or vapors.*

The DCU utilizes the following:

1. A terminal wiring board mounted at the bottom of the junction box.
2. A communication module mounted above the terminal wiring board using the standoffs provided. See Figure 3-48.

**Assembly and Wiring Procedure**

Attach the sensor to the DCU enclosure. Do not over-tighten. If a sensor separation kit is being used, attach the sensor to the separation kit junction box and wire the device as described in the "Sensor Separation" section.



**CAUTION**

*The sensor threads can be coated with an appropriate grease to ease installation. Also lubricate the cover threads. (See "Ordering Information" for part number of recommended lubricant.)*

Connect the external wiring to the appropriate terminals on the DCU terminal wiring board. Refer to Figure 3-49 for terminal identification.

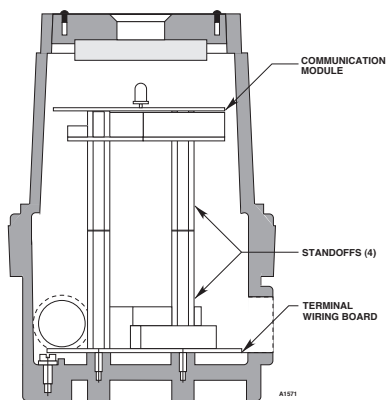

Figure 3-48—Printed Circuit Boards in Universal DCU

See Figure 3-50 for an example of a Det-Tronics electrochemical sensor connected to a DCU.

Attach the communication module to the standoffs as shown in Figure 3-48. Connect the ribbon cable from the terminal wiring board to the communication module.

Set the address for the device. Refer to "Setting Device Network Addresses" for complete information regarding the switch setting procedure.

Check the wiring to ensure proper connections, then pour the conduit seals and allow them to dry (if conduit is being used).

**NOTE**

*Before placing the cover back on the enclosure following completion of assembly and wiring, inspect the enclosure O-ring to be sure that it is in good condition and properly installed. Lubricate the O-ring and the threads of the cover with a thin coat of an appropriate grease to ease installation. Refer to the "Ordering Information" section for the part number of the recommended grease (available from Detector Electronics). If the installation uses catalytic type combustible gas sensors, it is imperative that lubricants containing silicone not be used, since they will cause irreversible damage to the sensor. Place the cover on the enclosure. Tighten only until snug. Do not over tighten.*

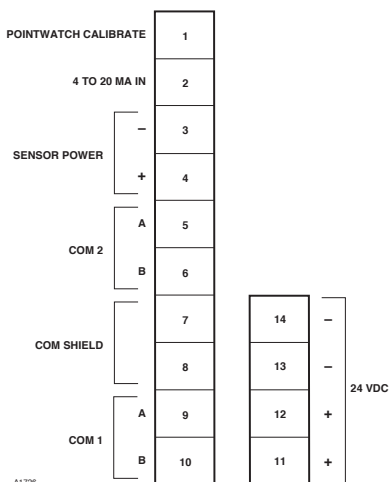

Figure 3-49—Wiring Configuration for DCU

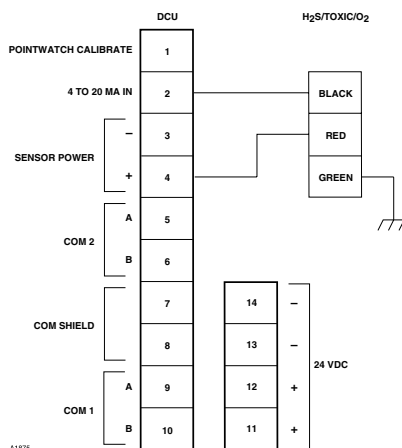

Figure 3-50—Electrochemical Sensor Connected to DCU

Table 3-12  
Maximum Separation Distances —  
Electrochemical Sensor to DCU

Wire Size (AWG)	Maximum Wiring Distance	
	Feet	Meters
18	5700	1750
16	9000	2800

T0020A

## Sensor Separation for DCU with H2S and O2 Sensors

Since the transmitter for the electrochemical sensor is already mounted within the sensor housing, simply mount the entire sensor assembly to the sensor separation kit junction box and wire it to terminals 2 and 4 inside the DCU, the same as a regular (without sensor separation) installation. Connect the shield to the ground terminal in the DCU junction box.

Refer to Table 3-12 for separation distance limitations for H2S and O2 sensors

## EQ22XXDCU DIGITAL COMMUNICATION UNIT USED WITH POINTWATCH/ DUCTWATCH

Determine the best mounting location for the detector. Whenever practical, detectors should be placed where they are easily accessible for calibration.



### WARNING

*Do not apply power to the system with the cover removed unless the area has been verified to be free of combustible gases and vapors.*

The DCU utilizes the following:

1. A terminal wiring board mounted at the bottom of the junction box.

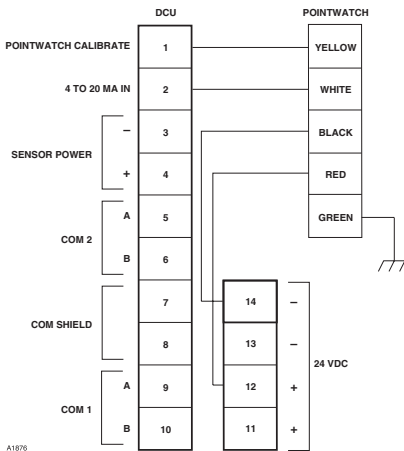

Figure 3-51—PointWatch/DuctWatch Connected to DCU

2. A communication module mounted above the terminal wiring board using the standoffs provided. See Figure 3-48.

## Assembly and Wiring Procedure

Attach the PointWatch/DuctWatch to the DCU enclosure. Do not over-tighten. If a sensor separation kit is being used, attach the sensor to the separation kit junction box and wire the device as described in the “Sensor Separation” section.

Refer to the PointWatch instruction manual (form number 95-8440) or the DuctWatch instruction manual (form number 95-8573) for complete installation and application information.

Refer to Figure 3-51 when wiring a PointWatch IR gas detector and a DCU. The wiring code for PointWatch is:

- Red = + (24 Vdc)
- Black = – (common)
- White = 4 to 20 mA signal
- Yellow = Calibration input
- Green = Chassis ground

Set the address for the device. Refer to “Setting Device Network Addresses” for complete information regarding the switch setting procedure.

## Sensor Separation for DCU with PointWatch

Shielded four wire cable is recommended for connecting the detector junction box to the DCU. Cable with a foil shield is recommended. The shield of the cable should be open at the detector junction box and connected to earth ground at the DCU junction box.

### NOTE

*To ensure proper operation, it is essential to maintain a minimum of 18 Vdc (including ripple) at the PointWatch detector.*

# EQ22XXDCUEX DIGITAL COMMUNICATION UNIT (USED WITH DET-TRONICS COMBUSTIBLE GAS SENSORS)

## Mounting

Determine the best mounting location for the device. Whenever practical, the device should be placed where it can easily be reached for calibration.

### IMPORTANT

*Always orient the junction box with the sensor pointing down.*



### WARNING

*Do not apply power to the system with the cover removed unless the area has been verified to be free of combustible gases or vapors.*

## Wiring

1. Remove the cover from the DCUEX.



### CAUTION

*ALWAYS discharge static from tools and hands by touching the device body before touching the communication module or transmitter board.*

2. Loosen the screws on the communication module and remove it from the transmitter board standoffs.
3. Disconnect the ribbon cable from the communication module.
4. Remove the standoffs and detach the transmitter board from the terminal wiring board. Do not disconnect any wiring.
5. Connect all external wiring to the terminal wiring board. (See Figure 3-52.)

### NOTE

*Make sure the ribbon cable is connected to the terminal wiring board.*

6. Attach the sensor to the device enclosure. DO NOT overtighten.

### NOTE

*If a sensor separation kit is being used, attach the sensor to the separation kit*

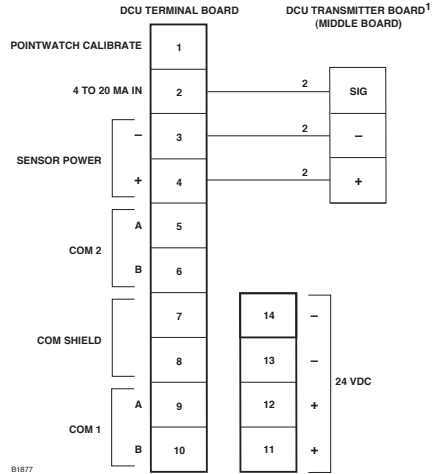

NOTES: 1 Catalytic Combustible Gas Sensor Plugs into Connector Pins on the Middle Board inside the Junction Box.  
2 Connections Wired at the Factory.

Figure 3-52—DCU Transmitter Board Connected to Terminal Wiring Board

*junction box. (See Sensor Separation with DCUEX below.)*

7. Plug the sensor into P2 on the transmitter board.
8. Mount the transmitter board to the terminal wiring board and attach with the standoffs.

### NOTE

*Be sure to note the correct orientation of the transmitter board. If the transmitter board is rotated 180° from proper orientation, the device will not operate correctly — a LON communication fault will result. See Figure 3-53.*

9. Plug the ribbon cable into the communication module and re-attach it to the transmitter board.
10. Set the device network address. (See “Setting Device Network Addresses” in this section.)



- Inspect the junction box O-ring to be sure that it is in good condition. Lubricate the O-ring and the threads of the junction box cover with a thin coat of silicone-free grease (available from Det-Tronics).
- Replace the device cover.

### Sensor Separation with DCUEX

If the installation requires mounting the sensor in a different location than the DCUEX, observe the following guidelines.

There are two methods that can be used to separate the sensor from the DCUEX:

#### Preferred Method

- Disassemble the DCUEX and remove the transmitter board. (Refer to "Wiring" for disassembly procedure.) Do not re-assemble at this time.
- Mount the transmitter board inside the sensor separation junction box (remove the existing board).

#### NOTE

*This assembly can be separated from the DCUEX by up to 1000 feet using three conductor 18 AWG shielded cable. (Regardless of separation distance, operating voltage at the transmitter must be at least 18 Vdc for proper device operation.) (See Figure 3-54.)*

- Mount the sensor to the separation junction box. DO NOT overtighten. Plug the sensor into P2 on the transmitter board.
- Use a three conductor 18 AWG shielded cable to connect P1 on the transmitter board to terminals 2, 3 and 4 on the DCU terminal board (See Figure 3-54). Connect the shield to the ground terminal in the DCUEX junction box.
- Connect all external wiring to the terminal wiring board inside the DCU (if not already completed). Re-assemble the DCUEX as described in the "Wiring" section. When completed, it should look similar to the DCU as shown in Figure 3-48.

- Inspect the O-ring on the DCU and separation junction box to be sure that they are in good condition. Lubricate the O-ring and the threads of the junction box cover with a thin coat of silicone-free grease (available from Det-Tronics).
- Replace the cover on the DCU and separation junction box.

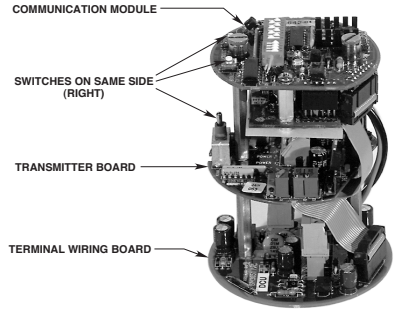

CORRECT ORIENTATION OF TRANSMITTER BOARD

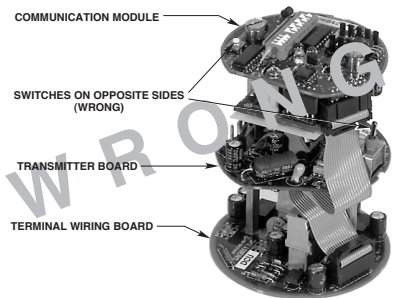

INCORRECT ORIENTATION OF TRANSMITTER BOARD

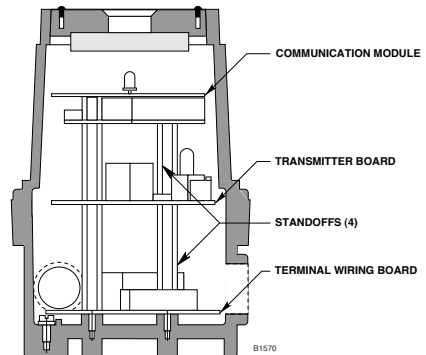

Figure 3-53—Printed Circuit Boards in Combustible Gas DCU

## Alternate Method

If the transmitter board must be mounted separate from the sensor (high temperature applications, etc.), separate the sensor only, leaving the transmitter PC board inside the DCUEX enclosure. When using this installation option, see Table 3-13 for maximum wiring distances.

Mount the sensor directly to the separation kit junction box. Use three conductor shielded cable for the connection between the terminal block in the separation kit junction box and P2 on the DCUEX transmitter board.

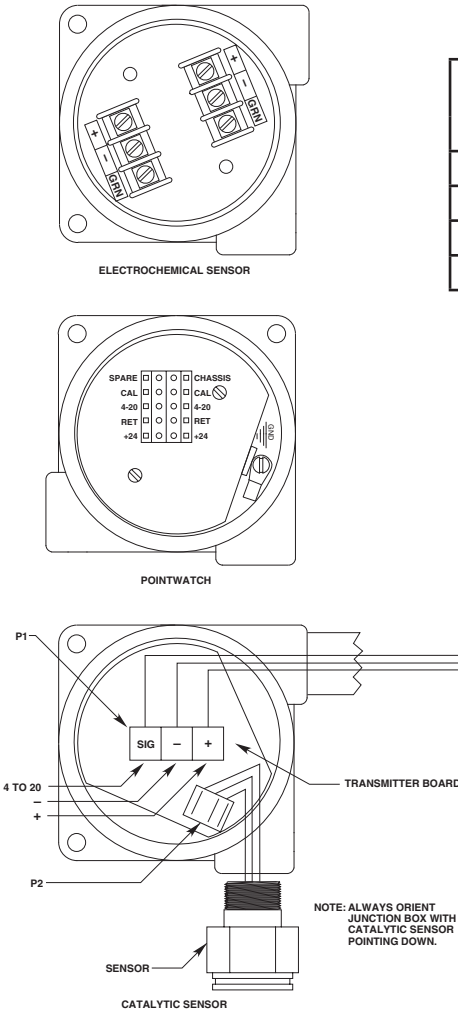

Figure 3-54—Sensor Separation Kits

A plug with screw terminals is provided for connecting the cable to P2 on the transmitter board. Observe the wiring color code. Connect the shield to the ground terminal in the DCUEX junction box.

## TYPICAL APPLICATIONS

Figure 3-55 is a simplified drawing of a typical EQP system. This system includes an EQP Controller, DCIO and various LON field devices.

Table 3-13—Maximum Separation Distances —  
Combustible Gas Sensor to DCU (Alternate Method)

Wire Size	Maximum Separation Distance	
	Feet	Meters
18 AWG (1.0 mm <sup>2</sup> )*	40	12
16 AWG (1.5 mm <sup>2</sup> )*	60	18
14 AWG (2.5 mm <sup>2</sup> )*	100	30
12 AWG (4.0 mm <sup>2</sup> )*	150	45

\*Approximate Metric Equivalent.

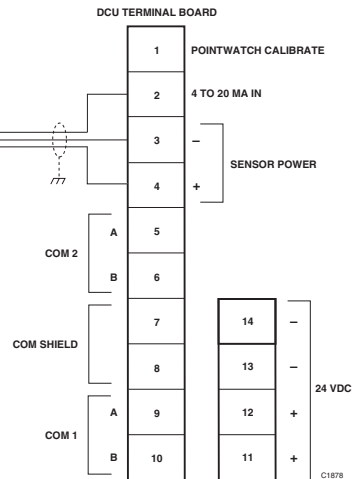

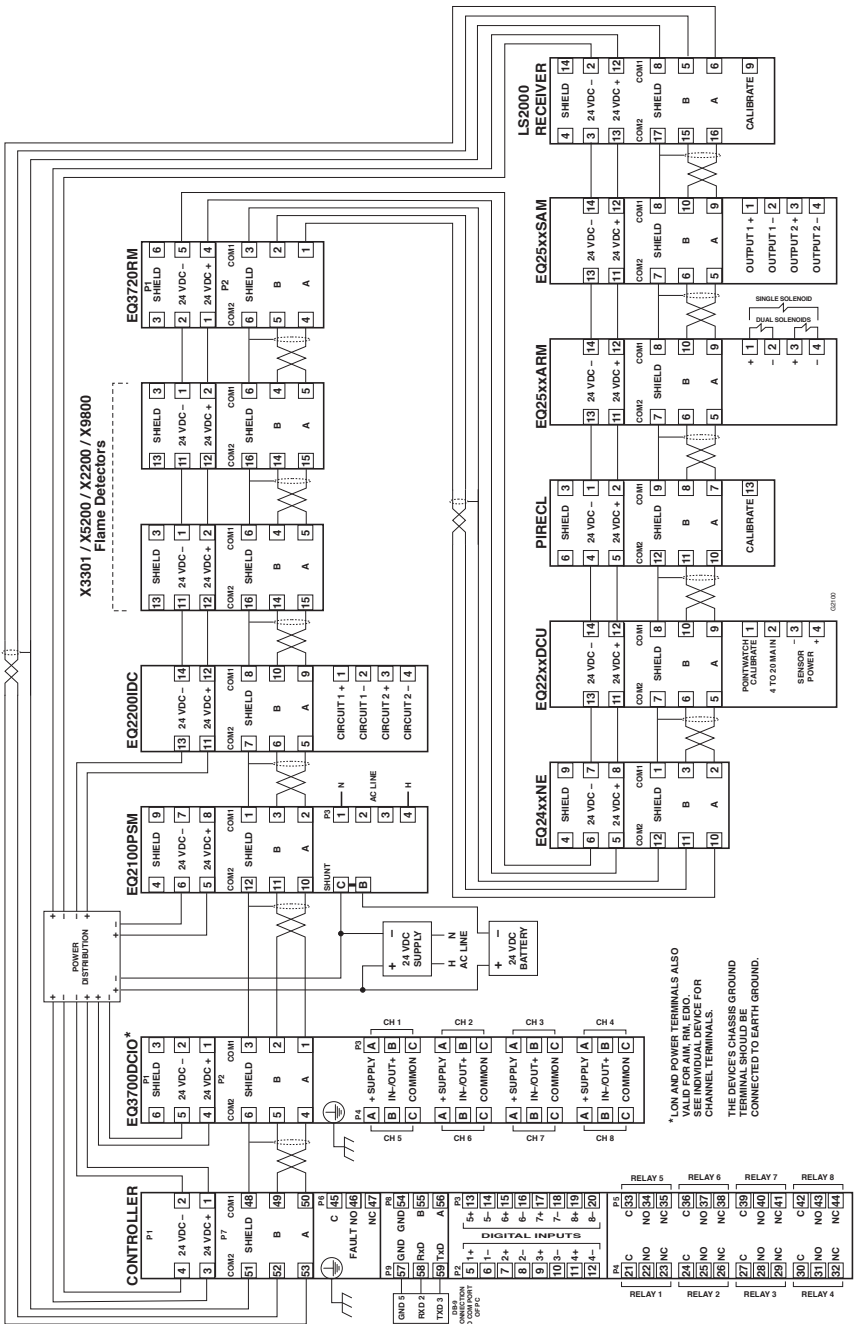

\*ON AND POWER TERMINALS ALSO VALID FOR AIR EMO. SEE INDIVIDUAL DEVICE FOR CHANNEL TERMINALS.

THE DEVICE'S CHASSIS GROUND TERMINAL SHOULD BE CONNECTED TO EARTH GROUND.

Figure 3-55—A Typical System

# SYSTEM CONFIGURATION

## SETTING DEVICE NETWORK ADDRESSES

### Overview of Network Addresses

Each device on the LON must be assigned a unique address. Addresses 1 to 4 are reserved for the controller. Valid addresses for field devices are from 5 to 250.

### IMPORTANT

*If the address is set to zero or an address above 250, the communication module will ignore the switch setting.*

Duplicated addresses are not automatically detected. Modules given the same address will use the number given and report to the controller using that address. A "Rogue Device" message will be displayed when two LON devices have duplicate addresses assigned to them. The status word will show the latest update, which could be from any of the reporting modules using that address.

### Setting Field Device Addresses

Selection of the node address for field devices is done by setting rocker switches on an 8 switch "DIP Switch" within each device's housing.

### NOTE

*Only the first eight of the 12 switches are used for selecting the device address.*

The address number is binary encoded with each switch having a specific binary value with switch 1 being the LSB (Least Significant Bit). (See Figure 3-56) The device's LON address is equal to the added value of all closed rocker switches. All "Open" switches are ignored.

### NOTE

*The address switches in the DCIO module and relay module appear slightly different than those in other devices. Refer to Figure 3-57.*

**Example:** for node No. 5, close rocker switches 1 and 3 (binary values 1 + 4); for node No. 25, close rocker switches 1, 4 and 5 (binary values 1 + 8 + 16).

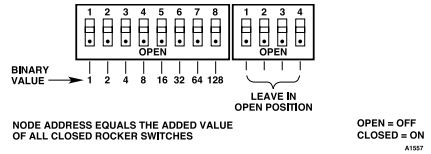

Figure 3-56—Field Device Address Switches for ARM, SAM, DCU and IDC

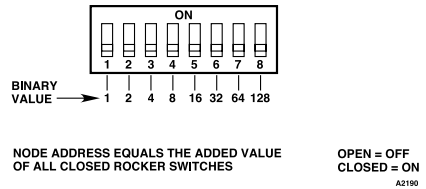

Figure 3-57—Address Switch for DCIO and Relay Module

### NOTE

*The field device sets the LON address only when power is applied to the device. Therefore, it is important to set the switches **before** applying power. If an address is ever changed, system power must be cycled before the new address will take effect.*

After setting address switches, record the address number and device type on the "Address Identification Chart" provided with this manual. Post the chart in a convenient location near the Controller for future reference.

## Rocker Switch Table

Node Address	Rocker Switch								Node Address	Rocker Switch							
	1	2	3	4	5	6	7	8		1	2	3	4	5	6	7	8
1	X	O	O	O	O	O	O	O	61	X	O	X	X	X	X	O	O
2	O	X	O	O	O	O	O	O	62	O	X	X	X	X	X	O	O
3	X	X	O	O	O	O	O	O	63	X	X	X	X	X	X	O	O
4	O	O	X	O	O	O	O	O	64	O	O	O	O	O	O	X	O
5	X	O	X	O	O	O	O	O	65	X	O	O	O	O	O	X	O
6	O	X	X	O	O	O	O	O	66	O	X	O	O	O	O	X	O
7	X	X	X	O	O	O	O	O	67	X	X	O	O	O	O	X	O
8	O	O	O	X	O	O	O	O	68	O	O	X	O	O	O	X	O
9	X	O	O	X	O	O	O	O	69	X	O	X	O	O	O	X	O
10	O	X	O	X	O	O	O	O	70	O	X	X	O	O	O	X	O
11	X	X	O	X	O	O	O	O	71	X	X	X	O	O	O	X	O
12	O	O	X	X	O	O	O	O	72	O	O	O	X	O	O	X	O
13	X	O	X	X	O	O	O	O	73	X	O	O	X	O	O	X	O
14	O	X	X	X	O	O	O	O	74	O	X	O	X	O	O	X	O
15	X	X	X	X	O	O	O	O	75	X	X	O	X	O	O	X	O
16	O	O	O	O	X	O	O	O	76	O	O	X	X	O	O	X	O
17	X	O	O	O	X	O	O	O	77	X	O	X	X	O	O	X	O
18	O	X	O	O	X	O	O	O	78	O	X	X	X	O	O	X	O
19	X	X	O	O	X	O	O	O	79	X	X	X	X	O	O	X	O
20	O	O	X	O	X	O	O	O	80	O	O	O	O	X	O	X	O
21	X	O	X	O	X	O	O	O	81	X	O	O	O	X	O	X	O
22	O	X	X	O	X	O	O	O	82	O	X	O	O	X	O	X	O
23	X	X	X	O	X	O	O	O	83	X	X	O	O	X	O	X	O
24	O	O	O	X	X	O	O	O	84	O	O	X	O	X	O	X	O
25	X	O	O	X	X	O	O	O	85	X	O	X	O	X	O	X	O
26	O	X	O	X	X	O	O	O	86	O	X	X	O	X	O	X	O
27	X	X	O	X	X	O	O	O	87	X	X	X	O	X	O	X	O
28	O	O	X	X	X	O	O	O	88	O	O	O	X	X	O	X	O
29	X	O	X	X	X	O	O	O	89	X	O	O	X	X	O	X	O
30	O	X	X	X	X	O	O	O	90	O	X	O	X	X	O	X	O
31	X	X	X	X	X	O	O	O	91	X	X	O	X	X	O	X	O
32	O	O	O	O	O	X	O	O	92	O	O	X	X	X	O	X	O
33	X	O	O	O	O	X	O	O	93	X	O	X	X	X	O	X	O
34	O	X	O	O	O	X	O	O	94	O	X	X	X	X	O	X	O
35	X	X	O	O	O	X	O	O	95	X	X	X	X	X	O	X	O
36	O	O	X	O	O	X	O	O	96	O	O	O	O	O	X	X	O
37	X	O	X	O	O	X	O	O	97	X	O	O	O	O	X	X	O
38	O	X	X	O	O	X	O	O	98	O	X	O	O	O	X	X	O
39	X	X	X	O	O	X	O	O	99	X	X	O	O	O	X	X	O
40	O	O	O	X	O	X	O	O	100	O	O	X	O	O	X	X	O
41	X	O	O	X	O	X	O	O	101	X	O	X	O	O	X	X	O
42	O	X	O	X	O	X	O	O	102	O	X	X	O	O	X	X	O
43	X	X	O	X	O	X	O	O	103	X	X	X	O	O	X	X	O
44	O	O	X	X	O	X	O	O	104	O	O	O	X	O	X	X	O
45	X	O	X	X	O	X	O	O	105	X	O	O	X	O	X	X	O
46	O	X	X	X	O	X	O	O	106	O	X	O	X	O	X	X	O
47	X	X	X	X	O	X	O	O	107	X	X	O	X	O	X	X	O
48	O	O	O	O	X	X	O	O	108	O	O	X	X	O	X	X	O
49	X	O	O	O	X	X	O	O	109	X	O	X	X	O	X	X	O
50	O	X	O	O	X	X	O	O	110	O	X	X	X	O	X	X	O
51	X	X	O	O	X	X	O	O	111	X	X	X	X	O	X	X	O
52	O	O	X	O	X	X	O	O	112	O	O	O	O	X	X	X	O
53	X	O	X	O	X	X	O	O	113	X	O	O	O	X	X	X	O
54	O	X	X	O	X	X	O	O	114	O	X	O	O	X	X	X	O
55	X	X	X	O	X	X	O	O	115	X	X	O	O	X	X	X	O
56	O	O	O	X	X	X	O	O	116	O	O	O	X	O	X	X	O
57	X	O	O	X	X	X	O	O	117	X	O	X	O	X	X	X	O
58	O	X	O	X	X	X	O	O	118	O	X	X	O	X	X	X	O
59	X	X	O	X	X	X	O	O	119	X	X	X	O	X	X	X	O
60	O	O	X	X	X	X	O	O	120	O	O	O	X	X	X	X	O

## Rocker Switch Table

Node Address	Rocker Switch								Node Address	Rocker Switch							
	1	2	3	4	5	6	7	8		1	2	3	4	5	6	7	8
121	X	O	O	X	X	X	X	O	191	X	X	X	X	X	X	O	X
122	O	X	O	X	X	X	X	O	192	O	O	O	O	O	O	X	X
123	X	X	O	X	X	X	X	O	193	X	O	O	O	O	O	X	X
124	O	O	X	X	X	X	X	O	194	O	X	O	O	O	O	X	X
125	X	O	X	X	X	X	X	O	195	X	X	O	O	O	O	X	X
126	O	X	X	X	X	X	X	O	196	O	O	X	O	O	O	X	X
127	X	X	X	X	X	X	X	O	197	X	O	X	O	O	O	X	X
128	O	O	O	O	O	O	O	X	198	O	X	X	O	O	O	X	X
129	X	O	O	O	O	O	O	X	199	X	X	X	O	O	O	X	X
130	O	X	O	O	O	O	O	X	200	O	O	O	X	O	O	X	X
131	X	X	O	O	O	O	O	X	201	X	O	O	X	O	O	X	X
132	O	O	X	O	O	O	O	X	202	O	X	O	X	O	O	X	X
133	X	O	X	O	O	O	O	X	203	X	X	O	X	O	O	X	X
134	O	X	X	O	O	O	O	X	204	O	O	X	X	O	O	X	X
135	X	X	X	O	O	O	O	X	205	X	O	X	X	O	O	X	X
136	O	O	O	X	O	O	O	X	206	O	X	X	X	O	O	X	X
137	X	O	O	X	O	O	O	X	207	X	X	X	X	O	O	X	X
138	O	X	O	X	O	O	O	X	208	O	O	O	O	X	O	X	X
139	X	X	O	X	O	O	O	X	209	X	O	O	O	X	O	X	X
140	O	O	X	X	O	O	O	X	210	O	X	O	O	X	O	X	X
141	X	O	X	X	O	O	O	X	211	X	X	O	O	X	O	X	X
142	O	X	X	X	O	O	O	X	212	O	O	X	O	X	O	X	X
143	X	X	X	X	O	O	O	X	213	X	O	X	O	X	O	X	X
144	O	O	O	O	X	O	O	X	214	O	X	X	O	X	O	X	X
145	X	O	O	O	X	O	O	X	215	X	X	X	O	X	O	X	X
146	O	X	O	O	X	O	O	X	216	O	O	O	X	X	O	X	X
147	X	X	O	O	X	O	O	X	217	X	O	O	X	X	O	X	X
148	O	O	X	O	X	O	O	X	218	O	X	O	X	X	O	X	X
149	X	O	X	O	X	O	O	X	219	X	X	O	X	X	O	X	X
150	O	X	X	O	X	O	O	X	220	O	O	X	X	X	O	X	X
151	X	X	X	O	X	O	O	X	221	X	O	X	X	X	O	X	X
152	O	O	O	X	X	O	O	X	222	O	X	X	X	X	O	X	X
153	X	O	O	X	X	O	O	X	223	X	X	X	X	X	O	X	X
154	O	X	O	X	X	O	O	X	224	O	O	O	O	O	X	X	X
155	X	X	O	X	X	O	O	X	225	X	O	O	O	O	X	X	X
156	O	O	X	X	X	O	O	X	226	O	X	O	O	O	X	X	X
157	X	O	X	X	X	O	O	X	227	X	X	O	O	O	X	X	X
158	O	X	X	X	X	O	O	X	228	O	O	X	O	O	X	X	X
159	X	X	X	X	X	O	O	X	229	X	O	X	O	O	X	X	X
160	O	O	O	O	O	X	O	X	230	O	X	X	O	O	X	X	X
161	X	O	O	O	O	X	O	X	231	X	X	X	O	O	X	X	X
162	O	X	O	O	O	X	O	X	232	O	O	O	X	O	X	X	X
163	X	X	O	O	O	X	O	X	233	X	O	O	X	O	X	X	X
164	O	O	X	O	O	X	O	X	234	O	X	O	X	O	X	X	X
165	X	O	X	O	O	X	O	X	235	X	X	O	X	O	X	X	X
166	O	X	X	O	O	X	O	X	236	O	O	X	X	O	X	X	X
167	X	X	X	O	O	X	O	X	237	X	O	X	X	O	X	X	X
168	O	O	O	X	O	X	O	X	238	O	X	X	X	O	X	X	X
169	X	O	O	X	O	X	O	X	239	X	X	X	X	O	X	X	X
170	O	X	O	X	O	X	O	X	240	O	O	O	O	X	X	X	X
171	X	X	O	X	O	X	O	X	241	X	O	O	O	X	X	X	X
172	O	O	X	X	O	X	O	X	242	O	X	O	O	X	X	X	X
173	X	O	X	X	O	X	O	X	243	X	X	O	O	X	X	X	X
174	O	X	X	X	O	X	O	X	244	O	O	X	O	X	X	X	X
175	X	X	X	X	O	X	O	X	245	X	O	X	O	X	X	X	X
176	O	O	O	O	X	X	O	X	246	O	X	X	O	X	X	X	X
177	X	O	O	O	X	X	O	X	247	X	X	X	O	X	X	X	X
178	O	X	O	O	X	X	O	X	248	O	O	O	X	X	X	X	X
179	X	X	O	O	X	X	O	X	249	X	O	O	X	X	X	X	X
180	O	O	X	O	X	X	O	X	250	O	X	O	X	X	X	X	X
181	X	O	X	O	X	X	O	X									
182	O	X	X	O	X	X	O	X									
183	X	X	X	O	X	X	O	X									
184	O	O	O	X	X	X	O	X									
185	X	O	O	X	X	X	O	X									
186	O	X	O	X	X	X	O	X									
187	X	X	O	X	X	X	O	X									
188	O	O	X	X	X	X	O	X									
189	X	O	X	X	X	X	O	X									
190	O	X	X	X	X	X	O	X									

## Physical Disconnect Switch Wiring

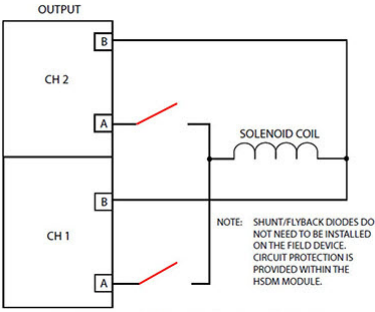

Figure 3-53A - Supervised Output Configuration with Solenoid Disconnect Switch - Class A

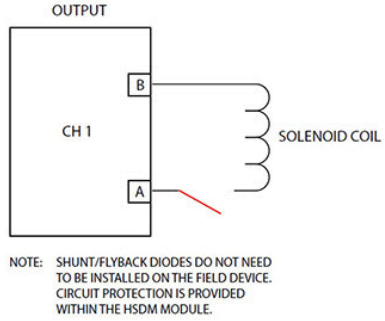
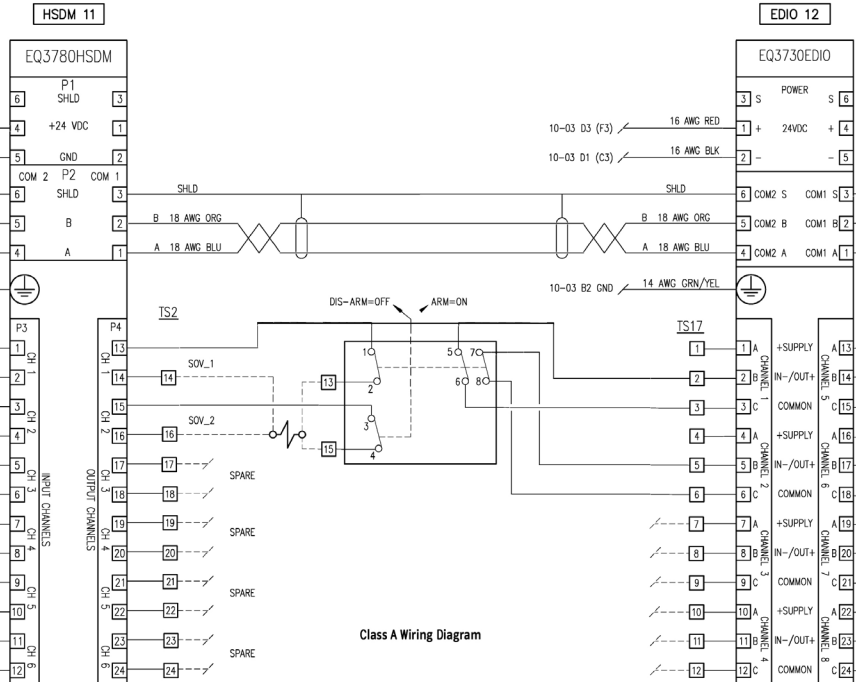

Figure 3-53B - Supervised Output Configuration with Solenoid Disconnect Switch - Class B

## Wiring Between EDIO and HSDM Modules



Class A Wiring Diagram

Figure 3-53C - Supervised Output Configuration between EDIO and HSDM modules - Class A

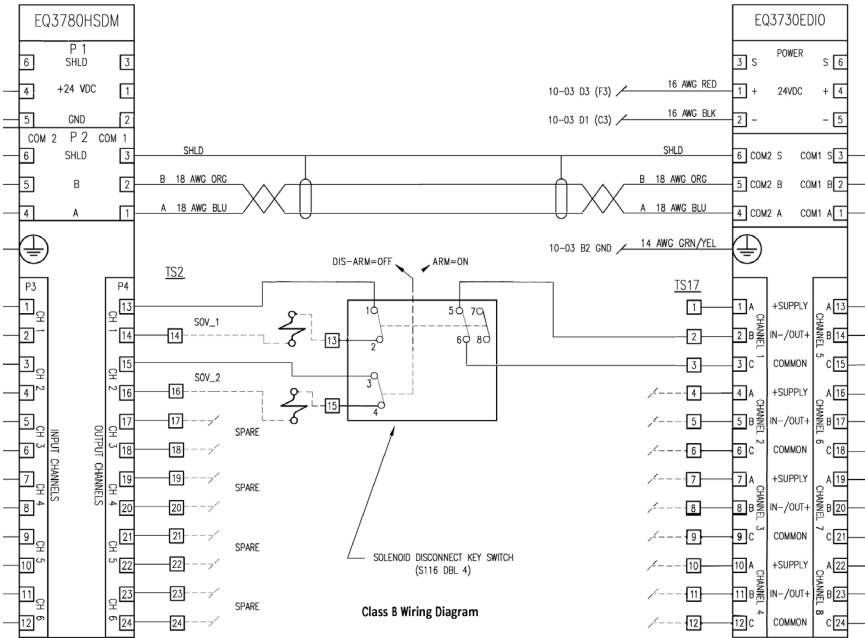

Figure 3-53D - Supervised Output Configuration between EDIO and HSDM modules - Class B



## Section 4 Operation

### SYSTEM CONTROLLER

#### PUSHBUTTONS

The Controller has seven pushbuttons (located on the front panel) for user interface. These pushbuttons allow the operator to interact with the Controller to respond to alarms and system status conditions, access system status reports, and configure Controller time and date settings.

The following paragraphs describe the function of each pushbutton. Refer to Figure 4-1 for Controller pushbutton locations.

**Cancel** cancels the selected command, and returns the menu to the last option list displayed.

**Enter** chooses the menu item selected, and advances the menu to the next options list. (See “Controller Menu Options” in this section for additional information.)

#### NOTE

*Pressing Enter while alarms are actively scrolling returns the display to the Main Menu.*

**Next** allows the operator to scroll through options listed within each menu. Each time the NEXT pushbutton is pushed, the current options list indexes up one list item. (See “Controller Menu Options” in this section for additional information)

**Previous** allows the operator to scroll through options listed within each menu. Each time the PREVIOUS pushbutton is pushed, the current options list indexes down one list item. (See “Controller Menu Options” in this section for additional information)

**Reset** resets all controller latched outputs that are no longer active.

**Acknowledge** silences the internal beeper.

**Silence** turns on the Silence LED and sets Silence status in user logic.

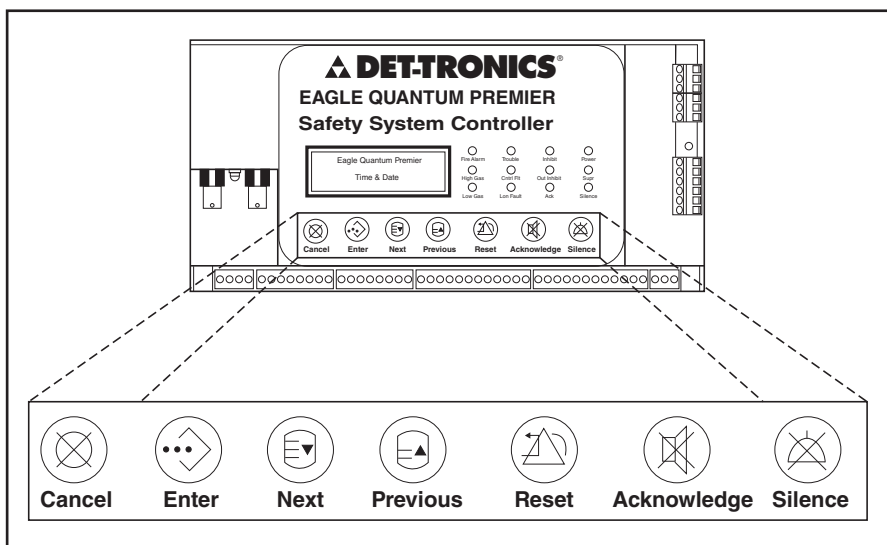

Figure 4-1—EQP Controller Pushbutton Locations

## CONTROLLER STATUS INDICATORS

System status is visually displayed on the Controller in two ways — through the use of a Text Display (see Figure 4-2), and through colored LED's (see Table 4-1). The following paragraphs describe these indicators and the function of each.

### TEXT DISPLAY

The Controller uses a text based display to show current system status, active Alarms and Faults.

When an alarm or trouble condition occurs, the display scrolls a detailed message of the condition, including tag number, condition (alarm, trouble, supervisory etc.) and time/date. If multiple alarms or trouble conditions exist, the display scrolls through all active status conditions until they go inactive and are reset using the controller pushbutton.

## CONTROLLER MENU OPTIONS

The Controller is designed to display system status and device related information. The following paragraphs describe how to move around within the controller's menu structure to access this information and perform minor system settings (see Figure 4-3).

### NOTE

*During normal operation (no alarms or trouble conditions occurring), the display scrolls current system time and date.*

**Main Menu** displays a list of options to access information types available for display through the Controller. This list also includes access to options used to set system date and time, and diagnostics options.

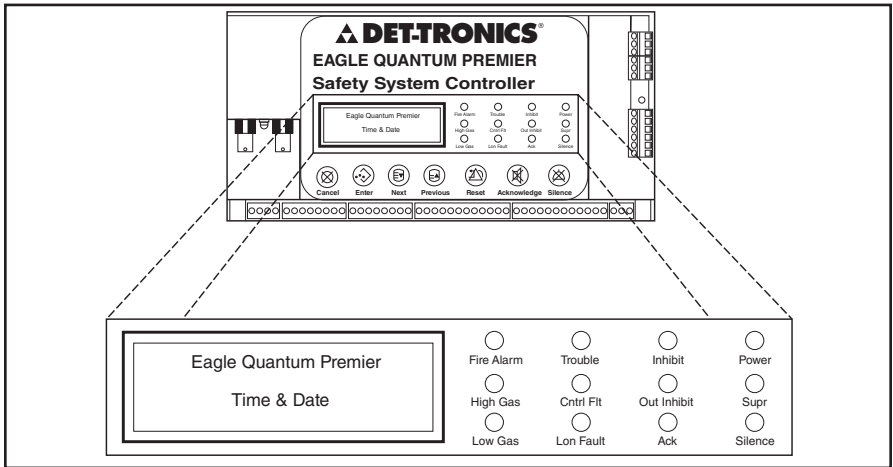

Figure 4-2—EQP Controller Message Display and System Status Indicator Location

Table 4-1—EQP Controller LED System Status Indicators

LED	Function	Status
Green	Power	On when power is applied.
Red	Fire Alarm	On (latched) when any fire alarm is active (Fire detected).
Yellow	Trouble	On (latched) when a fault is detected in the system. (Indicates "Trouble" relay state.)
Yellow	Ack	On when the Acknowledge button is pressed.
Yellow	Silence	On when Silence pushbutton is pressed.
Yellow	Inhibit	On when any input channel is inhibited.
Yellow	Out Inhibit	On when any output is inhibited.
Red	High Gas	On (latched) when any gas detector is at or above the High gas alarm value.
Red	Low Gas	On (latched) when any gas detector is at or above the Low gas alarm value.
Yellow	Supr	On (latched) when any Supervisory input is active.
Yellow	LON Fault	On when a LON fault is detected (open or short).
Yellow	Cntrl Fault	On when a processor fault occurs.

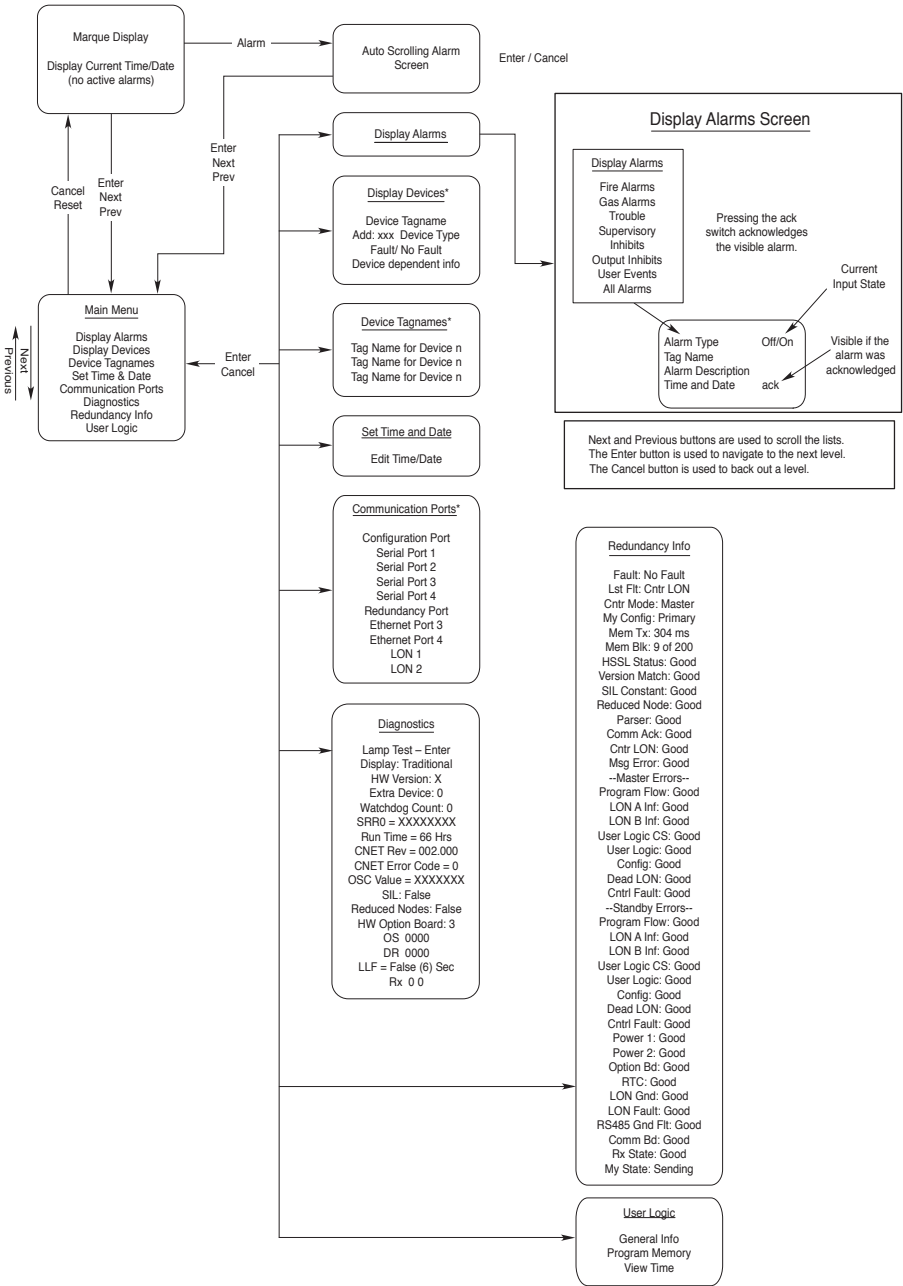

Figure 4-3—EQP Controller Message Display Menu Outline



Moving within the Main Menu is done by using the NEXT or PREVIOUS pushbuttons located on the controller's front panel. The menu options will scroll upward (NEXT Pushbutton) or downward (Previous Pushbutton) while the Main Menu name remains stationary. When the desired menu option is selected by the ">" indicator, the ENTER pushbutton is pressed to advance the menu display to the desired information set.

**NOTE**

*Pressing the CANCEL pushbutton from within any sub-menu returns the display to the Main Menu. The display will also return to the Main Menu if left unattended for a period of 20 minutes. If an alarm or trouble condition is present after 20 minutes, the display will change to the existing Alarm or Trouble message.*

**DISPLAY ALARMS** displays a list of existing Alarms and Trouble conditions. Moving within this menu is done by using the NEXT or PREVIOUS pushbuttons.



**NOTE**

*Multiple alarm information can be viewed by pressing the NEXT or PREVIOUS pushbuttons. Pressing CANCEL will return the menu to the DISPLAY ALARMS menu.*

**DISPLAY DEVICES** displays device information on all devices on the LON loop. Device tag name, type, and node address are displayed.

Pressing the NEXT or PREVIOUS pushbuttons allows cycling through devices. Pressing the CANCEL pushbutton will return the display to the Main Menu.

**DEVICE TAG NAMES** displays device tag name information for all devices on the LON loop.

Pressing the NEXT or PREVIOUS pushbutton allows cycling through devices. Pressing the CANCEL pushbutton will return the display to the Main Menu.

**SET TIME AND DATE** provides access to configuration controls for system clock and date settings.

**NOTE**

*When the Set Time and Date menu opens, the current hour will flash.*

To move within this menu, press the ENTER pushbutton until the desired property is flashing. To set the desired property value, press the NEXT Pushbutton to increase or PREVIOUS Pushbutton to decrease the value. When the desired value is displayed, press the ENTER pushbutton. This will advance the menu to the next property and it will flash. When all desired properties have been entered, press the ENTER pushbutton until the message "Press ENTER to Save" is displayed. When the ENTER pushbutton is pressed, the settings are saved and the menu changes back to the MAIN MENU.

**SERIAL PORTS** displays port information on all available ports.

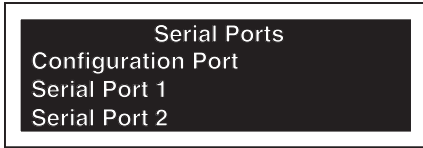

Pressing the NEXT or PREVIOUS pushbutton allows cycling through ports. Pressing the CANCEL pushbutton will return the display to the Main Menu.

**DIAGNOSTICS** displays information for factory field service.

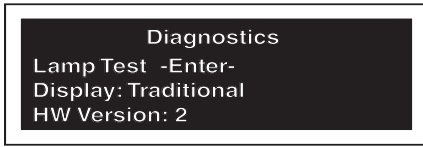

**REDUNDANCY INFO** displays the current status of all redundancy related faults. It can be used to monitor the health of the master and standby controllers. It can also be used for diagnostic purposes.

Redundancy faults originate from three general areas:

- Self detected internal failures of the master controller
- Inter-controller communications
- A failure in the standby controller.

Any redundancy fault is annunciated by the master controller, and the redundancy fault code of the highest priority fault is displayed. The controller also provides a diagnostic menu for more detailed information on the source of a redundancy problem. All redundancy related faults must be cleared to insure proper redundancy operation.

### Fault

Displays the current redundancy fault.

### Lst Fit

Displays the last redundancy fault that occurred.

### Cntr Mode

Indicates whether the controller is in master or standby mode.

### My Config

Indicates whether the controller is the primary or secondary controller.

### Redun Mem

Displays how long it takes to transfer the local and global memory between controllers.

### HSSL Status

An error is generated when a problem is detected on the high-speed communication link between controllers. This fault is annunciated when the standby controller is offline.

### Version Match

To ensure proper redundant operation, the firmware versions of redundant controllers must match. This error is set when a mismatch is detected. Consult the factory for firmware upgrades.

### SIL Rating

To ensure proper redundant operation, the SIL rating of redundant controllers must match. An error is indicated if a SIL controller is paired with a non-SIL rated controller. Consult the factory for details.

### Parser

As the master controller configures a standby controller, configuration information is extracted from non-volatile memory and checked for errors.

### Comm Ack

Critical information is exchanged between controllers on the HSSL using acknowledged messages. The master sends data packets that contain an embedded CRC and a transaction number. The standby validates the message by calculating and comparing the CRC values. If the CRC is correct the standby saves the data and returns an acknowledge message with the transaction number. If an acknowledge message with the proper transaction number is not received by the master within the allotted time the message is resent. When all retries are used the acknowledge error is indicted and acknowledged communication is terminated.

## Lon Comm

Redundant controllers exchange information across the LON network. This is primarily done to prevent both controllers from becoming the master in the event that the HSSL fails. The fault is annunciated when a controller fails to receive any information from the other controller.

## Msg Error

If the standby controller receives a message from the master that has the correct CRC but invalid data an error message is returned. This master will indicate the error with this fault.

## Program Flow

Program flow checking ensures that essential functions execute in the correct sequence. If any functions don't execute properly, or execute in the wrong order, the program flow error is set and control is transferred to the standby controller.

## LON A/B Inf

Controllers utilize neuron co-processors to interface with the field device network. If an error is detected in the operation of the co-processor, a LON interface fault is annunciated.

## User Logic CS

Controllers continually conduct a checksum test of the user logic program to ensure that the data remains unchanged. A user checksum fault is annunciated if the result is incorrect.

## App CS

When the controller firmware is generated a checksum of the program is calculated and saved in memory. Each controller is continually conducting a checksum test of the program to ensure that the data remains unchanged. The application checksum fault is annunciated if the result is incorrect.

## User Logic

Many checks are conducted while the controller interprets and executes the user program. The user logic error is generated if invalid or out of range data is detected.

## Config

This fault is annunciated when a controller has not been configured or the configuration information has been corrupted.

Table 4-2—EQP Controller Alarm Tone Patterns

Priority	Controller Tone	Tone Pattern
1	Fire Alarm	Temporal
2	Supervisory	Supervisory
3	Trouble	Trouble
4	High Gas	Gas
5	Low Gas	Gas
6	Normal	Off

### Power 1

Displays the power 1 status on the standby controller.

### Power 2

Displays the power 2 status on the standby controller.

### Option Bd

Indicates whether there is a fault on the ControlNet or Ethernet DLR option board of the standby controller.

## CONTROLLER AUDIBLE ALARM

The Controller features an internal audible alarm for local system status notification (see Table 4-2 and Figure 4-4). When the system is operating in the normal mode (no Alarm or Fault conditions occurring), the alarm is silent (off). If an event (any alarm or trouble condition) occurs, the alarm will remain active until it is acknowledged by pressing the Acknowledge pushbutton or reset by pressing the Reset pushbutton on the Controller front panel.

### NOTE

*If multiple alarms exist, "Acknowledging" will silence the audible alarms.*

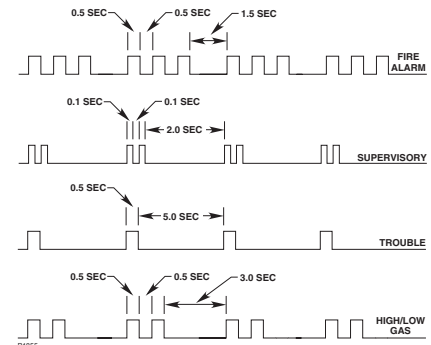

Figure 4-4—Tone Pattern for Controller Buzzer

Table 4-3—Status of ControlNet LED Indicators

A and B	Cause	Action
Off	No power	None or power up.
Steady red	Faulted unit	Cycle power. If fault persists, contact the factory.
Alternating red/green	Self-test	None
Alternating red/off	Incorrect node configuration	Check network address and other ControlNet configuration parameters.
<b>A or B</b>		
Off	Channel disabled	Program network for redundant media, if required.
Steady green	Normal operation	None
Flashing green/off	Temporary errors	None; unit will self-correct.
	Listen only	Cycle power.
Flashing red/off	Media fault	Check media for broken cables, loose connectors, missing terminators, etc.
	No other nodes present on network	Add other nodes to the network.
Flashing red/green	Incorrect network configuration	Cycle power or reset unit. If fault persists, contact the factory.

**CONTROLNET STATUS INDICATORS (Optional)**

The optional ControlNet status indicator LEDs function as follows: (see Table 4-3)

Steady - The indicator is on continuously in the defined state.

Alternating - The two indicators alternate between the two defined states at the same time (applies to both indicators viewed together). The two indicators are always in opposite states, out of phase.

Flashing - The indicator alternates between the two defined states (applies to each indicator viewed independent of the other). If both indicators are flashing, they must flash together, in phase.

**ETHERNET DLR STATUS INDICATORS (Optional)**

The Ethernet DLR has 4 status indicators: Module Status, Network Status, Link Status 1 and Link Status 2. See Figure 4-5 for location. The status indicator LEDs function as defined in Tables 4-4 through 4-6. A test sequence is performed on the Network Status and Module Status LEDs during startup.

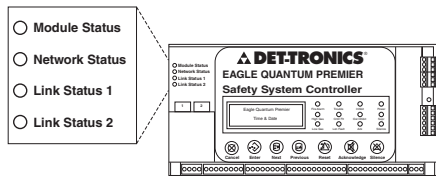

Figure 4-5—Location of Ethernet DLR Status LEDs

Table 4-4—Ethernet DLR Module Status LED

LED State	Description
Off	No power.
Green	Controlled by a Scanner in Run state.
Green, flashing	Not configured, or Scanner in idle state.
Red	Major fault (EXCEPTION state, FATAL error, etc.)
Red, flashing	Recoverable fault(s)

Table 4-5—Ethernet DLR Network Status LED

LED State	Description
Off	No power or no IP address.
Green	Online, one or more connections established (CIP Class 1 or 3).
Green, flashing	Online, no connections established.
Red	Duplicate IP address, FATAL error.
Red, flashing	One or More connections timed out (CIP Class 1 or 3).

**SEQUENCE OF EVENTS DURING A CONFIGURATION DATA DOWNLOAD**

During a configuration download, the controller receives configuration data that is stored into flash memory. During the download process, the controller halts normal operation and resets a number of controller functions. Items affected and displayed during a configuration data download are listed in the following steps:

1. Halt the static logic and user logic programs.
2. Ignore field device LON communications. However, the controller continues to generate the LON heartbeat.
3. Silence the Controller's audible annunciator.
4. Initiate a Trouble condition that is signaled by the yellow Trouble LED and relay.
5. Clear all Alarm and Fault events.
6. De-energize all 8 Controller relays.
7. Ignore Modbus communication.
8. ControlNet communication continues. Ethernet DLR communication goes through reset and configuration. DLR communication remains offline during this sequence (approximately 30 seconds).
9. Text display's first line indicates \*\*\*\* Program Mode \*\*\*\*
10. Text display's third line displays download status.
  - a) "Config Download" indicates the serial transfer into memory from the PC to the Controller.

Table 4-6—Ethernet DLR Link Status 1 and Link Status 2 LEDs

LED State	Description
Off	No link, no activity.
Green	Link (100 Mbit/s) established.
Green, flickering	Activity (100 Mbit/s)
Yellow	Link (10 Mbit/s) established.
Yellow, flickering	Activity (10 Mbit/s)

- b) "Erasing Flash" indicates that the controller is electronically erasing the contents of the Flash memory.
- c) "Writing to Flash" indicates that configuration data stored in memory is being written down into Flash memory.
- d) "Flash Lock" indicates that the controller is locking the configuration data into the Flash memory.



*The controller's configuration data will be corrupted if power is removed during a download. Contact the factory if this occurs.*

11. Initialize the RS-485 and configuration serial ports with new parameters.
12. Initialize the ControlNet or Ethernet DLR option board with new parameters.
13. Enable static logic and user logic programs to operate. The first scan program is run first.
14. Accept field device LON communications.
15. Poll the device type variable from LON field devices.
16. Configure LON field devices.
17. Clear the Trouble condition.
18. Text display shows a normal operation marquee message.
  - a) Text display's first line indicates "Det-Tronics Eagle Quantum Premier®."
  - b) Text display's third line displays time (24 hour format) and date (month/day/year).



## NOTE

*Depending on the condition of the LON devices, faults may persist for a number of minutes.*

## CONTROLLER REDUNDANCY

### Pushbuttons

The pushbuttons are active on the master controller and inactive on the standby controller.

### Controller Status Indicators

The status indicators are active on the master controller. All LEDs except the power LED are off and the trouble relay is in the no trouble state.

### Controller Relay Operation

The controller relays are fully functional on the master controller and the standby controller.

### Text Display

The text display on the master controller is fully functional as explained in the previous section. The text display on the standby controller reads **\*\*Standby Mode\*\***, Ready.

### Controller Menu Options

The menu options are active on the master controller and inactive on the standby controller.

### ControlNet or Ethernet DLR Status Indicators

The ControlNet or Ethernet DLR status indicators are active on the master and standby controller. See Table 4-3 for status of ControlNet LED indicators and Tables 4-4 through 4-6 for Ethernet DLR LED indicators.

### Power-up Sequence

The power-up sequence for a redundant controller pair is as follows:

1. Make sure the LON and HSSL are connected correctly.
2. Apply power to both controllers.
3. Controllers go through their boot-up routine.

4. The controller that is connected with the primary end of the HSSL is identified as the primary controller and is assigned address 1.
5. The controller that is connected with the secondary end of the HSSL is assigned address 2.
6. If there are no faults present, the primary controller defaults to the master controller and the secondary controller defaults to the standby controller.
7. The master controller executes user logic and communicates with the connected LON devices.
8. The standby controller indicates that it is in standby mode and monitors the master controller.
9. The master and standby controller go through a synchronization process.
10. The power-up sequence is complete.

### Synchronization

When a master controller detects a standby controller on the HSSL, it performs the following synchronization process:

1. Compare controller firmware versions and SIL rating. If they are not an exact match, the process stops and a fault is generated. Consult the factory for details.
2. Standby controller indicates the synchronization steps.
3. Compare the user application programs. If there is a mis-match, the master will configure the standby controller via the HSSL.
4. Initiate the data synchronization process.
5. Transfer the status of device inhibits and device removes.
6. Transfer the complete alarm list, including alarm history.
7. Transfer the real time clock (RTC) value.
8. Copy the local and global memory to the standby controller.
9. Synchronization is complete and the standby controller indicates "Ready."

## Sequence of Events During a Configuration Download



### WARNING

*The system is inactive and not executing logic/alarm functions during a program download (in both single and redundant controller configurations).*

When downloading a new configuration to the master controller, the following sequence is executed:

1. The S<sup>3</sup> software must be connected to the master controller.
2. Alter the configuration and execute the download command from S<sup>3</sup>.
3. The master controller goes into 'Program' mode and passes mastership to the standby controller.
4. The updated configuration file is loaded into the controller.
5. The controllers are automatically forced to switch over.
6. The master controller puts the standby controller into 'Program' mode and downloads the configuration.
7. The controller indicates "Device Download Active" until the LON devices have been successfully updated.
8. The configuration download is now complete.

### Manual Switchover

The user can request a manual switchover from an externally wired switch. The request executes the following sequence:

1. Verify that HSSL communication is good and there are no internal faults in the standby controller.
2. Verify that the synchronization process is complete.
3. The master requests the standby to take control.
4. The standby takes control and becomes the master.

5. The controller indicates "Device Download Active" until the LON devices have been successfully updated.

### Automatic Switchover

An automatic transfer will be initiated if the master controller goes into an error (self detected internal controller failure, program flow error in the controller, user logic checksum error or application checksum error). An automatic switchover executes the following sequence:

1. Check that the standby controller is online by verifying that HSSL communication is good and there are no internal faults in the standby controller.
2. Verify that the synchronization process is complete.
3. The master requests the standby to take control.
4. The standby takes control and becomes the master.

### Replacing a Faulty Controller

If the master controller fails and the standby controller is healthy, an automatic switchover will occur. To replace the failed controller, perform the following steps:

1. Remove power. Disconnect plugs and remove the failed controller.
2. Mount the new controller.
3. Connect the LON to the new controller.
4. Connect the HSSL.
5. Connect any other I/O used.
6. Apply power to the controller.
7. A controller synchronization occurs and the new controller is configured and indicates "Ready" as the standby controller.
8. If preferred, perform a manual switchover to return the primary controller to the master status.

# ENHANCED DISCRETE I/O MODULE

The EDIO Module (see Figure 4-6) has 18 LED status indicators, two for the device and two for each channel, located on the front panel. Refer to Tables 4-7 and 4-8 for a description of the LED indicators.

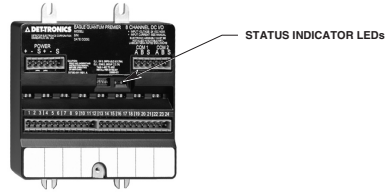

## POWER-UP SEQUENCE

Set the module address switch prior to applying power.

EDIO module power-up sequence illuminates the LEDs for the device and all of its channels. First the power and fault LEDs are illuminated, indicating that the device is in a power-up mode. Next the LEDs are illuminated in the following sequences:

- Sequentially each channel active red LED is illuminated, starting with channel 1 and continuing through channel 8.
- When the red LED for channel 8 is illuminated, sequentially each channel active red LED is turned off, starting with channel 1 and continuing through channel 8.
- Next, the channel fault yellow LEDs are tested in the same manner as the channel active red LEDs.

When all the LEDs have been illuminated, the EDIO module displays the device's LON address by illuminating the channel active red LED. LON dip switches 1 through 8 will be displayed on channels 1 through 8. When a dip switch is set to the ON position, the channel active red LED will be illuminated. The address is displayed for two seconds.

Once the address has been displayed, the device's fault LED will turn off.

After the power-up sequence, the device will either display an unconfigured state or normal operation state. In the unconfigured state, the channel fault yellow LEDs flash ON and OFF at the same rate for all channels.

If a channel is configured for supervision and it has a fault, the corresponding yellow LED and status parameter are activated. The positive and negative drivers on each channel are tested. If any driver test fails, the corresponding yellow LED and status parameter are activated.

Figure 4-6—EDIO Module Status Indicator Location

Table 4-7—EDIO Module - Device Status Indicators

LED	Device Status
Green	On when power is present.
Yellow	When On steady indicates device is disabled or must be replaced. Possible Watchdog Timer problem.  <i>NOTE</i> <i>Blinks one time at power-up.</i>

Table 4-8—EDIO Module - Channel Status Indicators

LED	Channel Status
Red	When On steady indicates the input circuit is closed or the output circuit is active
Yellow	When Blinking indicates a low power condition is present or channel is not properly configured. Steady indicates a channel fault.

## 8 CHANNEL DCIO MODULE

The DCIO Module (see Figure 4-7) has 18 LED status indicators, two for the device and two for each channel, located on the front panel. Refer to Tables 4-9 and 4-10 for a description of the LED indicators.

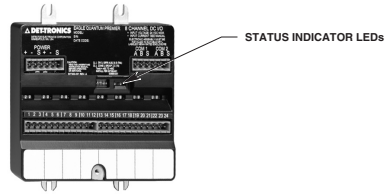

Figure 4-7—DCIO Module Status Indicator Location

### POWER-UP SEQUENCE

Set the module address switch prior to applying power.

DCIO module power-up sequence illuminates the LEDs for the device and all of its channels. First the power and fault LEDs are illuminated, indicating that the device is in a power-up mode. Next the LEDs are illuminated in the following sequences:

- Sequentially each channel active red LED is illuminated, starting with channel 1 and continuing through channel 8.
- When the red LED for channel 8 is illuminated, sequentially each channel active red LED is turned off, starting with channel 1 and continuing through channel 8.
- Next, the channel fault yellow LEDs are tested in the same manner as the channel active red LEDs.

When all the LEDs have been illuminated, the DCIO module displays the device's LON address by illuminating the channel active red LED. LON dip switches 1 through 8 will be displayed on channels 1 through 8. When a dip switch is set to the ON position, the channel active red LED will be illuminated. The address is displayed for two seconds.

Once the address has been displayed, the device's fault LED will turn off.

After the power-up sequence, the device will either display an unconfigured state or normal operation state. In the unconfigured state, the channel fault yellow LEDs flash ON and OFF at the same rate for all channels.

Table 4-9—DCIO Module - Device Status Indicators

LED	Device Status
Green	On when power is present.
Yellow	When On steady indicates device is disabled or must be replaced. Possible Watchdog Timer problem.  <i>NOTE</i> <i>Blinks one time at power-up.</i>

Table 4-10—DCIO Module - Channel Status Indicators

LED	Channel Status
Red	When On steady indicates the input circuit is closed or the output circuit is active
Yellow	When Blinking indicates a low power condition is present or channel is not properly configured. Steady indicates a channel fault.

## 8 CHANNEL RELAY MODULE

The Relay Module (see Figure 4-8) has 18 LED status indicators, two for the device and two for each channel, located on the front panel. Refer to Tables 4-11 and 4-12 for a description of the LED indicators.

### POWER-UP SEQUENCE

Set the module address switch prior to applying power.

Relay module power-up sequence illuminates the LEDs for the device and all of its channels. First the power and fault LEDs are illuminated, indicating that the device is in a power-up mode. Next the LEDs are illuminated in the following sequences:

- Sequentially each channel active red LED is illuminated, starting with channel 1 and continuing through channel 8.
- When the red LED for channel 8 is illuminated, sequentially each channel active red LED is turned off, starting with channel 1 and continuing through channel 8.
- Next, the channel fault yellow LEDs are tested in the same manner as the channel active red LEDs.

When all the LEDs have been illuminated, the relay module displays the device's LON address by illuminating the channel active red LED. LON dip switches 1 through 8 will be displayed on channels 1 through 8. When a dip switch is set to the ON position, the channel active red LED will be illuminated. The address is displayed for two seconds.

Once the address has been displayed, the device's fault LED will turn off.

After the power-up sequence, the device will either display an unconfigured state or normal operation state. In the unconfigured state, the channel fault yellow LEDs flash ON and OFF at the same rate for all channels.

If a channel is configured for supervision and it has a fault, the corresponding yellow LED and status parameter are activated. The positive and negative drivers on each channel are tested. If any driver test fails, the corresponding yellow LED and status parameter are activated.

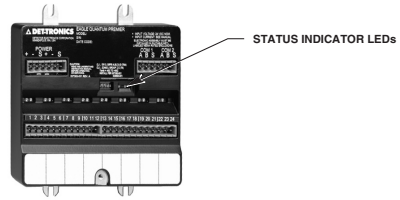

Figure 4-8—Relay Module Status Indicator Location

Table 4-11—Relay Module - Device Status Indicators

LED	Device Status
Green	On when power is present.
Yellow	When On steady indicates device is disabled or must be replaced. Possible Watchdog Timer problem.  <i>NOTE</i> <i>Blinks one time at power-up.</i>

Table 4-12—Relay Module - Channel Status Indicators

LED	Channel Status
Red	When On steady indicates the input circuit is active
Yellow	When Blinking indicates a low power condition is present or channel is not properly configured.

# ANALOG INPUT MODULE

The Analog Input Module (see Figure 4-9) has 18 LED status indicators, two for the device and two for each channel, located on the front panel. Refer to Tables 4-13 and 4-14 for a description of the LED indicators.

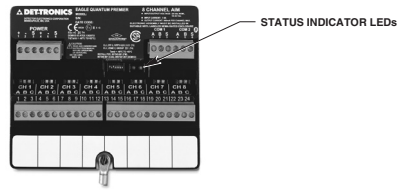

Figure 4-9—Analog Input Module Status Indicator Location

## POWER-UP SEQUENCE

Set the module address switch prior to applying power.

The Analog Input Module power-up sequence illuminates the LEDs for the device and all of its channels. First the power and fault LEDs are illuminated, indicating that the device is in a power-up mode. Next the LEDs are illuminated in the following sequences:

- Sequentially each channel active red LED is illuminated, starting with channel 1 and continuing through channel 8.
- When the red LED for channel 8 is illuminated, sequentially each channel active red LED is turned off, starting with channel 1 and continuing through channel 8.
- Next, the channel fault yellow LEDs are tested in the same manner as the channel active red LEDs.

When all the LEDs have been illuminated, the analog input module displays the device's LON address by illuminating the channel active red LED. LON dip switches 1 through 8 will be displayed on channels 1 through 8. When a dip switch is set to the ON position, the channel active red LED will be illuminated. The address is displayed for two seconds.

Once the address has been displayed, the device's fault LED will turn off.

After the power-up sequence, the device will either display an unconfigured state or normal operation state. In the unconfigured state, the channel fault yellow LEDs flash ON and OFF at the same rate for all channels.

Table 4-13—Analog Input Module - Device Status Indicators

LED	Device Status
Green	On when power is present.
Yellow	When On steady indicates device is disabled or must be replaced. Possible Watchdog Timer problem.  <i>NOTE</i> <i>Blinks one time at power-up.</i>

Table 4-14—Analog Input Module - Channel Status Indicators

LED	Channel Status
Red	When Blinking indicates a low alarm. When On Steady indicates a high alarm.
Yellow	When Blinking indicates a low power condition is present or channel is not properly configured. On steady indicates out of range condition

# EQ21XXPSM POWER SUPPLY MONITOR

The power supply monitor (see Figure 4-10) has three LEDs used to provide a visual indication of device status:

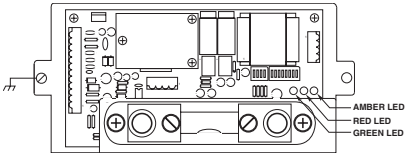

Figure 4-10—EQ21xxPSM Status Indicator Location

Table 4-15—Power Supply Monitor Status Indicators

LED	Device Status
Green	When On indicates power is supplied to device
Red	When Flashing indicates an alarm or fault condition is present.
Yellow	When On indicates device is disabled. Module must be replaced.

# EQ2220GFM GROUND FAULT MONITOR

The ground fault monitor (see Figure 4-11) has three LEDs used to provide a visual indication of device status:

**NOTE**

*The Ground Fault Monitor LED will respond immediately to a ground fault condition. The relay contact requires the condition to exist for 10 seconds before it activates.*

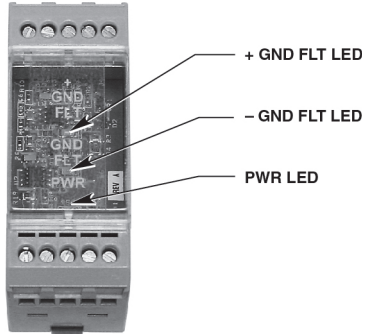

A2243

Figure 4-11—Ground Fault Monitor Status Indicator Location

Table 4-16—Ground Fault Monitor Status Indicators

LED	Device Status
+ GND FLT LED	Indicates Yellow in the presence of a "+" ground fault.
- GND FLT LED	Indicates Yellow in the presence of a "-" ground fault.
POWER LED	Indicates Green when the unit is powered.

## EQ22XXDCU AND EQ22XXDCUEX DIGITAL COMMUNICATION UNITS

The DCUs have three LEDs to provide a visual indication of device status. They are visible through the window on the enclosure cover.

### NOTE

*If the communication module has not been configured, the red LED blinks at a 4 Hz rate.*

### NOTE

*The yellow LED is provided for factory diagnostic purposes and is not used in the system. Illumination of the yellow LED normally indicates a failure in the communication chip. Replacement of the communication module circuit board is required.*

Table 4-18—DCU Status Indicators

Device Status	LED Status
Power-up	Pulsed at a rate of 0.5 Hz
Calibration	Pulsed at a rate of 1 HZ or on steady
Fault	Pulsed at a rate of 4 Hz
Alarm	On steady

## EQ24XXNE NETWORK EXTENDER/EQ24XXPLR PHYSICAL LAYER REPEATER

The EQ24xxNE has three LEDs (one green, two yellow) for indicating device status.

Table 4-19—Network Extender Status Indicators

LED	Device Status
Green	When On indicates device has power.  Flashes to indicate messages are being transferred over the LON.
Yellow	When On indicates a malfunction in the electronic circuitry. Module replacement is required.  <b>NOTE</b>  <i>When a network extender has an internal fault, the message display will only indicate that there is a LON fault condition existing somewhere on the LON.</i>



# SYSTEM STARTUP

## PRE-OPERATION CHECKS

### General

Insulate all shields to prevent shorts to device housing or to any other conductor.

Place alarm/release output in "Bypass/Isolate" when servicing devices.

Maintain a log book containing the type and serial numbers of devices as well as the location and date of installation.

Maintain a log of maintenance activities.

Observe normal precautions for handling electrostatic sensitive devices.

### LON

Rocker switches for each LON device must be set to the desired address prior to power-up.

Test the loop with no power applied. DC resistance should be equal on A and B.

Check polarity on A and B (no rolls). COM 1 connects to COM 2; COM 2 connects to COM 1. A connects to A and B to B.

Measure voltage. A to chassis ground measures approximately +7.5 Vdc. B to ground measures approximately -7.5 Vdc.

Measure signal (400 mv P-P min.). (Use oscilloscope if possible.)

Check fault tolerance by introducing a short.

### Controller

The I/O and LON wiring is correctly installed, observing polarity. All cable shields are properly terminated and insulated.

Power wiring is installed and power source is operational.

Chassis ground stud must be connected to earth ground.

### Redundant Controller

The I/O and LON wiring is correctly installed, observing polarity. All cable shields are properly terminated and insulated.

Power wiring is installed and power source is operational.

Chassis ground stud must be connected to earth ground.

The HSSL cable is connected between the two controllers.

### EDIO/DCIO Module

Verify correct address setting.

Check signal circuits for correct polarity.

Check for correct installation of EOL resistors.

### Relay Module

Verify correct address setting.

Check for correct output connections.

### Analog Input Module

Verify correct address setting.

Check for correct input connections.

Check each channel with a loop current input.

### Power Supplies and Power Monitors

Verify all earth ground connections as specified in the wiring instructions.

Verify correct ac power to supply.

Check power distribution to ensure that all devices are receiving power.

Check power trouble indicator by introducing an open to the battery.

## Ground Fault Monitor

Verify earth ground connections as specified in the wiring instructions.

Check power distribution to ensure that all devices are receiving power.

## DCUs

Verify correct address setting.

Check modules for correct orientation.

Check for the presence of contaminants or poisoning agents.

Device should be oriented with the sensor pointing down.

## IDCs

Verify correct address setting.

Check for correct installation of EOL resistors.

## ARMs

Verify correct address setting.

Check jumpers.

## SAMs

Verify correct address setting.

Check signal circuits for correct polarity.

Check for correct installation of EOL resistors.

Check jumpers.

### NOTE

*Please reference EQP Large Scale Installation manual (95-8770) for more information on legacy products, including DCUs, IDCs, ARMs, and SAMs.*

## GENERAL START-UP PROCEDURES

1. Output loads that are controlled by the system should be secured (remove power from all output devices) to prevent actuation.
2. Check all system wiring for proper connection.
3. Inspect all devices to verify that they have not been physically damaged in shipment.
4. Apply power to the system.

### NOTE

*To prevent the network modules from going into a fault isolation condition, apply power to the EQP Controller prior to applying power to the network devices.*

5. Program the system for the desired operation using Det-Tronics Safety System Software (S<sup>3</sup>). Download configuration data to all devices.

### NOTE

*After system configuration has been completed, the entire system should be tested for proper operation to ensure that configuration was performed properly.*

6. Calibrate the sensors.
7. Ensure that all trouble and alarm conditions have been cleared and the EQP Controller is reset, then remove mechanical blocking devices (if used) and restore power to the output loads.

## START-UP PROCEDURE FOR CONTROLLER

The Controller is powered-up when the Power Supply is turned on. When the Power Supply has been powered-up, verify power at the Controller by verifying that the Green LED indicator is on. This indicator is located on the front of the Controller.

To verify that the Controller is powered-up and operating properly, ensure that:

1. When power is first applied, all LEDs are on. The ACK LED flashes while the memory test is running. When initialization is complete, only the green power LED remains lit.
2. The Ethernet/Serial communication indicators continuously flash (if active).

### NOTE

*For the Ethernet Interface Board, the blue LEDs associated with ports 3 and 4 will remain on when the ports are ready for communication. Flashing green and yellow LEDs indicate active transmit and receive. The yellow indicator on the front of the RJ45 connector indicates a 10 Mb/s link is established. The green indicator on the front of the RJ45 connector indicates a 100 Mb/s link is established.*

3. The Text display runs an initialization routine. When initialization is complete and if all alarms and trouble conditions are cleared, the text display shows the current time and date. If the controller has been unpowered for more than 12 hours, the time and date may have to be set. If an alarm or trouble condition exists, it will be displayed until the condition is corrected and the Reset button is pressed.

If the controller has not been software configured, unconfigured devices will be displayed. Configuration must be done using S<sup>3</sup> Safety System Software before proceeding.

4. The LEDs on the front panel provide an indication of the system status.
5. Ensure configuration was performed properly.
6. After any modifications have been made either to the installation or to configuration software, always check the entire system for proper operation in order to ensure that the changes were performed properly.

## STARTUP PROCEDURE FOR EDIO MODULE

### Configuration

The EDIO Module is an eight-channel device. Each channel is capable of being configured as an input or output, independent of any other channel.

### NOTE

*The module is configured using Det-Tronics Safety System Software.*

### Activation Time

Timers are made available for output circuits only. Timers are used primarily to set the timing of output release in a suppression system. Timers provide a pulse timed output for the time period specified in the configuration of the channel. The channel output goes active when commanded by the system logic and remains on until the timer expires.

### Static Logic Mode

Each input channel can be configured as a Fire Alarm, Trouble, Low Gas Alarm, High Gas Alarm, Supervisory, or Other type of channel, independent of any other channel configuration. The type selected determines the logic the system uses to configure Indicators, Alarms and Messages.

For example: When an input is selected as Fire type, the Fire LED on the Controller and Audible alarm will automatically actuate when that input channel is active.

## **EDIO Startup**

1. The Power-on LED should be illuminated. The Fault LED should blink once on power up, then remain off.
2. The input circuits should indicate the proper state of the input device (channel active LED illuminates when the circuit is closed). Check the input power supply and associated wiring. Verify proper voltage per the Troubleshooting matrix.
3. The output circuits should indicate the proper state for the programmed device (channel active LED illuminates when the circuit is active). Check the power supply and associated wiring. Verify proper voltage per the Troubleshooting matrix.
4. The circuits should not indicate a fault condition (channel fault LED illuminates when the circuit is in fault). Check the end-of-line devices and associated wiring. Verify proper voltage per the Troubleshooting matrix.
5. Test the entire system for proper operation to ensure that the configuration was performed properly.

## **STARTUP PROCEDURE FOR DCIO MODULE**

### **Configuration**

The DCIO Module is an eight-channel device. Each channel is capable of being configured as an input or output, independent of any other channel.

### **NOTE**

*The module is configured using Det-Tronics Safety System Software.*

### **Activation Time**

Timers are made available for output circuits only. Timers are used primarily to set the timing of output release in a suppression system. Timers provide a pulse timed output for the time period specified in the configuration of the channel. The channel output goes active when commanded by the system logic and remains on until the timer expires.

### **Static Logic Mode**

Each input channel can be configured as a Fire Alarm, Trouble, Low Gas Alarm, High Gas Alarm, Supervisory, or Other type of channel, independent of any other channel configuration. The type selected determines the logic the system uses to configure Indicators, Alarms, and Messages.

For example: When an input is selected as Fire type, the Fire LED on the Controller and Audible alarm will automatically actuate when that input channel is active.

## **DCIO Startup**

1. The Power-on LED should be illuminated. The Fault LED should blink once on power up, then remain off.
2. The input circuits should indicate the proper state of the input device (channel active LED illuminates when the circuit is closed). Check the input power supply and associated wiring. Verify proper voltage per the Troubleshooting matrix.
3. The output circuits should indicate the proper state for the programmed device (channel active LED illuminates when the circuit is active). Check the power supply and associated wiring. Verify proper voltage per the Troubleshooting matrix.
4. The circuits should not indicate a fault condition (channel fault LED illuminates when the circuit is in fault). Check the end-of-line devices and associated wiring. Verify proper voltage per the Troubleshooting matrix.
5. Test the entire system for proper operation to ensure that the configuration was performed properly.

## **Relay Module Startup**

1. The Power-on LED should be illuminated. The Fault LED should blink once on power up, then remain off.
2. The output circuits should indicate the proper state for the programmed device (channel active LED illuminates when the circuit is active).
3. Test the entire system for proper operation to ensure that the configuration was performed properly.

## **Analog Input Module Startup**

1. The Power-on LED should be illuminated. The Fault LED should blink once on power up, then remain off.
2. The input circuits should indicate the proper state for the programmed device (channel active LED illuminates when the circuit is active).
3. The circuits should not indicate a fault condition (channel fault LED illuminates when the circuit is in fault).
4. Test the entire system for proper operation to ensure that the configuration was performed properly.

## Section 5 Maintenance

### NOTE

*Refer to the Eagle Quantum Premier® System Safety Manual (number 95-8599) for specific requirements and recommendations applicable to the proper installation, operation, and maintenance of all SIL-Certified EQP systems.*

## ROUTINE MAINTENANCE

To ensure reliable protection, it is important to check and calibrate the system on a regularly scheduled basis. The frequency of checks is determined by the requirements of the particular installation.

### BATTERIES

Batteries **must** be replaced every 48 months, or sooner if required by local codes.

### IMPORTANT

*Only sealed batteries are to be used.*

### MANUAL CHECK OF OUTPUT DEVICES

It is important that response devices be checked initially when the system is installed, as well as periodically during an on-going maintenance program.



### CAUTION

*Be sure to secure all output devices that are actuated by the system to prevent unwanted activation of equipment, and remember to place these output devices back into service when the checkout is complete.*

### O-RING MAINTENANCE



### WARNING

*The hazardous area must be de-classified prior to removing a junction box cover with power applied.*

A rubber O-ring is used to ensure that the junction box cover will seal tightly and provide protection against water entry. The enclosure

should be opened periodically, and the O-ring inspected for breaks, cracks and dryness.

To test O-ring: remove it from the enclosure and stretch it slightly. If cracks are visible, replace it. If it feels dry, a thin coating of lubricant should be applied. When re-installing the O-ring, be sure that it is properly seated in the housing groove. It is imperative that this O-ring be properly installed and in good condition. Failure to properly maintain it can allow water to enter the enclosure and cause premature failure. A coating of lubricant should also be applied to the threads on the cover before re-assembling the enclosure. This will both lubricate the cover threads and help prevent moisture from entering the enclosure.



### CAUTION

*The O-rings should be lubricated with a silicone free grease. The use of other lubricants is not recommended, since they can adversely affect the performance of some sensors. Under no circumstances should a lubricant or compound containing silicone be used on systems using catalytic type combustible gas sensors.*

## GAS SENSOR MAINTENANCE

All gas sensors must be calibrated on a regular basis. Calibration should typically be performed every 90 days for catalytic and electrochemical sensors.

Catalytic sensors have a finite lifespan. If a successful calibration cannot be performed, replace the sensor and recalibrate following the procedure described in the "Calibration" section below. **Always compare part numbers to be sure that the correct replacement sensor is being used.**



### CAUTION

*Exposure of the sensor to high concentrations of combustible gases for extended periods of time can introduce stress to the sensing element and seriously affect its performance. After exposure, recalibration should immediately be performed, and the sensor should be replaced if necessary.*

## NOTE

Electrochemical sensors have a finite lifespan. If a successful calibration cannot be performed, inspect the hydrophobic filter. If the filter is plugged, replace it and recalibrate the sensor. If the filter is in good condition, replace the sensor. Recalibrate following the procedure described in the "Calibration" section.

## CALIBRATION AND ADJUSTMENTS

To ensure optimum performance, calibration must be performed on a regularly scheduled basis. Since each application is different, the length of time between regularly scheduled recalibrations can vary from one installation to the next. In general, the more frequently a system is checked, the greater the reliability.

### IMPORTANT

*4–20 mA devices not manufactured by Det-Tronics must be pre-calibrated. To ensure adequate protection, calibration must be performed on a regularly scheduled basis.*

## NOTE

*If the calibration procedure is not completed within 12 minutes, the detector will revert back to the previous calibration values. The red LED will blink. The calibration will be logged as aborted.*

## NOTE

*The "Sensor Replacement" calibration procedure must be used for the initial calibration of a new sensor. The "Routine Calibration" procedure can be used for all subsequent calibrations.*

## NOTE

*Some calibration procedures require the operator to activate the reed switch located on a circuit board inside the junction box. See Figure 5-1 for reed switch location. To activate the switch, hold the calibration magnet against the side of the junction box near the switch location approximately one inch above the mounting surface. (Do not open the junction box.) Hold the calibration*

*magnet in place for approximately four seconds to initiate the calibration procedure.*

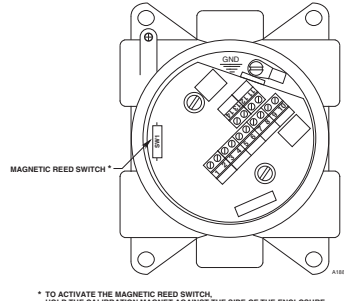

Figure 5-1—

DCU Terminal Wiring Board Mounted in Six-Port Junction Box

## CALIBRATION ALGORITHM A FOR MANUAL CALIBRATION OF UNIVERSAL DCU

### Normal Calibration

1. Activate the reed switch. (The red LED blinks while the reed switch is closed.)
2. After the reed switch has been closed for three seconds, the calibrate LED blinks, indicating it is ready for the zero input.
3. Enter the zero input (4 mA).
4. Activate the reed switch. (The red LED blinks while the switch is closed.)
5. After the reed switch has been closed for three seconds, the communication module records the uncalibrated value in the calibration log and calibrates the zero value. (The calibrate LED stays on steady.)
6. Apply the calibration gas.
7. The calibrate LED blinks as the input increases.
8. Activate the reed switch. (The red LED blinks while the reed switch is closed.)
9. The communication module records the uncalibrated value in the calibration log and calibrates the span value after the reed switch is on for three seconds.
10. The calibrate LED stays on steady.

11. Remove the span gas, and return the analog input to normal.
12. Activate the reed switch. (The red LED blinks for three seconds while the reed switch is closed.)
13. The calibration is complete. The calibrate LED turns off.

**NOTE**

*If the calibration is not completed within 12 minutes, the previous calibration values are restored and the calibration is logged as aborted. The calibrate LED will flash.*

**Sensor Replacement**



**WARNING**

*The hazardous area must be de-classified prior to removing a junction box cover with power applied.*

1. Open the junction box cover and press the Sensor Replacement Switch.
2. The calibrate LED on the communication module will flash, indicating it is ready for the zero input.
3. Replace the sensor and apply the zero input (4 mA).
4. Activate the reed switch. (The red LED flashes for three seconds while the switch is closed.)
5. The communication module records the uncalibrated value in position one of the calibration log and calibrates the zero value. (The calibrate LED stays on steady.)
6. Apply the calibration gas.
7. The calibrate LED flashes when the input increases.
8. Activate the reed switch. (The red LED flashes for three seconds while the reed switch is closed.)
9. The communication module records the uncalibrated value in the first register of the calibration log and calibrates the span value.
10. The calibrate LED stays on steady.

11. Remove the span gas and return the analog input to normal.
12. Activate the reed switch. (The red LED flashes for three seconds while the switch is closed.)
13. The calibration is complete. (The calibrate LED turns off.)

**NOTE**

*Pressing the Sensor Replacement Switch aborts calibration and starts over.*

**NOTE**

*Resetting the communication module will abort the sensor replacement.*

**CALIBRATION ALGORITHM C  
FOR COMBUSTIBLE GAS DCUS AND  
AUTOMATIC CALIBRATION OF  
UNIVERSAL DCUs**



**CAUTION**

*After exposing the H2S sensor to high concentrations of gas, it should be exposed to fresh air for at least 30 minutes, and re-calibrated.*

**Routine Calibration**

1. Apply the zero gas.
2. Activate the reed switch for at least four seconds. (The red LED flashes for three seconds while the switch is activated.)
3. The calibrate LED on the communication module flashes, indicating it is ready for the zero input.
4. Wait until the calibrate LED stays on steady (approximately four seconds).

**NOTE**

*The communication module records the uncalibrated value in the calibration log and calibrates the zero value during this time.*

5. Apply the calibration gas. (The calibrate LED flashes when the sensor detects gas.)
6. When the sensor input has been stable for 30 seconds, the communication module records the uncalibrated value in the calibration log, and calibrates the span value.



7. The calibrate LED stays on steady.
8. Remove the calibration gas.
9. The communication module waits until the sensor input drops below 4% full scale.
10. The calibration is complete. (The calibrate LED turns off.)

**NOTE**

*If the calibration procedure is not completed within 12 minutes, calibration will be aborted and the detector will revert back to the previous calibration values. The red LED will flash and the calibration will be logged as aborted.*

**Initial Installation and Sensor Replacement — Combustible Gas (CGS Sensor)**

**NOTE**

*When replacing a sensor, compare part numbers to be sure that the correct replacement sensor is used.*



**WARNING**

*The hazardous area must be de-classified prior to removing a junction box cover with power applied.*

1. Remove the cover from the DCUEX enclosure.
2. Press the Sensor Replacement Switch on the communication module for approximately one second. (The calibrate LED on the communication module flashes, indicating that it is ready for the zero input.)

**NOTE**

*Pressing the sensor replacement switch prevents the communication module from generating a fault signal when the input drops to zero due to sensor removal. The calibration will not be aborted if the calibration procedure is not completed within 12 minutes.*

3. Move the Calibration Switch to the “calibrate” position.
4. Replace the sensor.

5. Connect a volt meter to the test points on the transmitter board. Connect the “+” lead to TP1 (red). Connect the “-” lead to TP2 (black).
6. Wait at least five minutes for the sensor output to stabilize, then adjust R2 for a reading of 0.40 Vdc (4 mA) on the meter.

**NOTE**

*Do not make adjustments to R1 when calibrating the sensor.*

7. Move the Calibrate Switch to the “normal” position.
8. Activate the reed switch for four seconds. (The red LED flashes for three seconds while the switch is activated.) The communication module records the uncalibrated value in position one of the calibration log and calibrates the zero value. The calibrate LED goes on steady.
9. Move the Calibration Switch to the “calibrate” position.
10. Apply the calibration gas and wait for the output to stabilize.
11. With 50% LFL calibration gas applied to sensor, adjust R3 for a reading of 1.2 Vdc (12 mA) on the volt meter.
12. Move the Calibrate Switch to the “normal” position. (The red LED flashes.)
13. Activate the reed switch. The red LED flashes for three seconds while the switch is activated.
14. The communication module records the uncalibrated value in the first register of the calibration log and calibrates the span value. The calibrate LED stays on steady.
15. Remove the calibration gas and replace the DCU enclosure cover.
16. The communication module waits until the analog value drops below 4% full scale. The calibration is complete. (The calibrate LED turns off.)

**NOTE**

*Pressing the Sensor Replacement Switch aborts the current calibration.*

## Sensor Replacement — Toxic Gas

### NOTE

*When replacing a sensor, compare part numbers to be sure the correct replacement sensor is being used.*



### WARNING

*The hazardous area must be de-classified prior to removing a junction box cover with power applied.*

1. Remove the cover from the DCU enclosure.
2. Press the Sensor Replacement Switch on the communication module for approximately one second. (The calibrate LED flashes, indicating it is ready for the zero input.)

### NOTE

*Pressing the Sensor Replacement Switch prevents the communication module from generating a fault signal when the input drops to zero due to sensor removal. The calibration will **not** be aborted if the calibration procedure is not completed within 12 minutes.*

3. Replace the sensor.
4. Wait at least five minutes for the sensor output to stabilize.
5. Activate the reed switch. (The red LED flashes for three seconds while the switch is activated.) The communication module records the uncalibrated value in position one of the calibration log and calibrates the zero value. (The calibrate LED stays on steady.)
6. Apply the calibration gas. (The calibrate LED flashes when the input increases.)
7. Activate the reed switch. (The red LED flashes for three seconds while the switch is activated.)
8. The communication module records the uncalibrated value in the first register of the calibration log and calibrates the span value. (The calibrate LED stays on steady.)

9. Remove the calibration gas and replace the DCU enclosure cover.
10. The communication module waits until the analog value drops below 4% full scale. The calibration is complete. (The calibrate LED turns off.)

### NOTE

*Pressing the Sensor Replacement Switch aborts the calibration and starts over.*

## CALIBRATION ALGORITHM D FOR UNIVERSAL DCUs WITH O<sub>2</sub> SENSOR

### Normal Calibration

1. Apply clean air (20.9% oxygen).
2. Activate the reed switch for at least four seconds. (The red LED flashes for three seconds while the switch is closed.)
3. The calibrate LED flashes, indicating calibration has begun.
4. The communication module waits three seconds.
5. The communication module records the uncalibrated value in the calibration log and calibrates the span value.
6. The calibrate LED stays on steady.
7. The communication module waits three seconds.
8. Calibration is complete. (The calibrate LED turns off.)

### Sensor Replacement



### WARNING

*The hazardous area must be de-classified prior to removing a junction box cover with power applied.*

1. Open the junction box cover and press the Sensor Replacement Switch.
2. The calibrate LED on the communication module flashes, indicating it is ready for the zero input.
3. Replace the sensor and set the Sensor Switch (located on the sensor cell) to zero.

4. Activate the reed switch. (The red LED flashes for three seconds while the switch is closed.)
  5. The communication module records the uncalibrated value in position one of the calibration log and calibrates the zero value. The calibrate LED stays on steady.
  6. Set the Zero Switch on the sensor to the "normal" position. Apply clean air (20.9% oxygen) to set the sensor analog span value.
  7. The calibrate LED flashes when the input goes high.
  8. Activate the reed switch. (The red LED flashes for 3 seconds while the switch is closed.)
  9. The communication module records the uncalibrated value in the first register of the calibration log and calibrates the span value.
  10. The calibration is complete. The calibrate LED turns off.
7. The calibrate LED stays on steady.
  8. Remove the calibration gas.
  9. The communication module waits until the sensor input drops below 4% full scale.
  10. The calibration is complete. (The calibrate LED turns off.)

**NOTE**

*Calibration is aborted if not complete within 12 minutes. If not completed, the detector will revert back to the previous calibration values. The red LED will flash and the calibration will be logged as aborted.*

**Sensor Replacement**



**WARNING**

*The hazardous area must be de-classified prior to removing a junction box cover with power applied.*

1. Remove power from the DCU and PointWatch/DuctWatch unit. Replace the PointWatch unit. Apply power. Press the Sensor Replacement Switch on the communication module for approximately 1 second.

**NOTE**

*Allow at least 10 minutes for the sensor to warm up.*

**NOTE**

*Pressing the Sensor Replacement Switch prevents the communication module from generating a fault signal when the input drops to zero.*

**NOTE**

*The calibration will not be aborted if the calibration procedure is not completed within 12 minutes*

2. Apply zero gas.
3. The calibrate LED flashes, indicating that it is ready for the zero input.
4. Continue from step 4 of the PointWatch/ DuctWatch routine calibration procedure described above.

**NOTE**

*Pressing the sensor replacement switch aborts the calibration.*

**CALIBRATION ALGORITHM G FOR DCUs WITH POINTWATCH OR DUCTWATCH**

**Routine Calibration**

1. Apply the zero gas.
2. Activate the reed switch for at least 4 seconds. (The red LED flashes for 3 seconds while the switch is activated.)
3. The calibrate LED flashes, indicating it is ready for the zero input.
4. When a steady zero reading is obtained, the communication module records the uncalibrated value in the calibration log and calibrates the zero value during this time. The LED stays on steady.
5. Apply calibration gas. (The calibrate LED flashes when the sensor detects gas.)
6. When the sensor input has been stable for 30 seconds, the communication module records the uncalibrated value in the calibration log and calibrates the span value.

## DEVICE CALIBRATION LOGS AND RECORDS

The DCU keeps a calibration log in non-volatile memory that can be used by the operator to evaluate the remaining life of some sensors. This log includes the zero, span, date and time for each successful calibration. An aborted calibration is indicated by zeros in the zero and span values. The calibration log is cleared when the sensor replacement switch is pressed and the calibration is successfully completed.

The initial calibration is logged in position one, where it remains for the life of the sensor. If more than eight calibrations are performed without the sensor replacement switch being pressed, the newest calibration data will replace the second oldest so that the initial calibration data can be saved. The old calibration data will be lost. This feature enables sensor sensitivity trending to aid in maintenance or troubleshooting.

The analog value for the sensor is represented in raw analog-to-digital counts 0 to 4095, where 0 represents 0 ma and 4095 represents 24 mA.

## TROUBLESHOOTING

Tables 5-1 and 5-2 are provided to assist in locating the source of a system problem.

## REPLACEMENT PARTS

Eagle Quantum Premier® devices are not designed to be repaired in the field. If a problem should develop, first carefully

check for proper wiring, programming and calibration. If it is determined that the problem is caused by an electronic defect, the device must be returned to the factory for repair.

### NOTE

*When replacing a device, be sure that all rocker switches on the replacement are set the same as the original device. Consult the settings documented during system installation and setup to determine proper settings for the new device. Remove power before removing a device or plugging in a replacement unit. When a device is replaced, configuration is done automatically.*

## DEVICE REPAIR AND RETURN

Prior to returning devices or components, contact the nearest local sales representative so that a Return Material Authorization (RMA) number can be assigned. A written statement describing the malfunction must accompany the returned device or component to expedite finding the cause of the failure. This information is captured using the RMA form.

Pack the unit or component properly. Use sufficient packing material in addition to an antistatic bag or aluminum-backed cardboard as protection from electrostatic discharge.

Return all equipment transportation prepaid to the factory in Minneapolis with the RMA number clearly displayed. Materials received without an RMA number will be refused.

Table 5-1—Troubleshooting Guide - DCIO Module

I/O Type	Normal (Off)	Normal (On)	Open (Off)	Open (On)	Short (Off)	Short (On)
Unsupervised Input	-15.4	0	-15.4	-15.4	0	0
Supervised Input (EOL Resistor)	-14.4	0	-15.4	-15.4	0	0
Supervised Input (EOL/Inline Resistors)	-15.4	-15	-15.4	-15.4	0	0
Unsupervised Output	-15.4	23.9	-15.4	23.9	0	0
Supervised Output (Agent Release)	0 to 2.1 Note 2	23.9	-15.4	23.9	0	0
Supervised Output (Notification)	-14.4	23.9	-15.4	23.9	0	0

#### Notes:

- All measurements are in Volts and are measured in reference to the common terminal and 24.0 Vdc is the module's input.
- Value is dependent on the resistance of the solenoid attached.

Table 5-2—System Controller Troubleshooting Guide

Symptom	Possible Cause	Corrective Action
Controller Power LED/ Text Display OFF	No Power to Input.	<ul style="list-style-type: none"> <li>– Measure input voltage (18 to 30 Vdc).</li> <li>– Check that P1 is fully inserted.</li> <li>– If voltage is present and P1 is fully inserted, replace controller.</li> </ul>
LON Fault – LED lit	LON wiring is shorted or open.	<ul style="list-style-type: none"> <li>– Check that P7 is fully inserted.</li> <li>– Using the EQ Safety System Software, determine the location of open or short via LON Diagnostics screen.</li> <li>– Use a multimeter to determine wiring fault.</li> </ul>
Trouble - LED lit and relay is active.	Any monitored device in the system including ground fault in fault condition.	<ul style="list-style-type: none"> <li>– Using the front panel display/controls, view all points in alarm/fault and identify faulted device.</li> <li>– Repair or replace faulted device as necessary.</li> </ul>
Digital inputs are not responding	<ul style="list-style-type: none"> <li>– Bad input switch.</li> <li>– Faulty input channel.</li> <li>– Faulty wiring.</li> <li>– Configuration error.</li> </ul>	<ul style="list-style-type: none"> <li>– Check that P2 and P3 are fully inserted.</li> <li>– Using a voltmeter, measure input terminals with contact closed to the input (measures 0 vdc when input contact is closed, measures approximately 23 Vdc with circuit open and 24 vdc input at the controller).</li> <li>– If input does not respond to a contact closure, replace module (verify response with EQ Safety System Software/textual display).</li> <li>– Verify configuration.</li> </ul>
Relay Outputs are not respond to an output command	<ul style="list-style-type: none"> <li>– Bad relay channel.</li> <li>– Faulty output wiring.</li> <li>– User logic.</li> </ul>	<ul style="list-style-type: none"> <li>– Check that P4 and P5 are fully inserted.</li> <li>– When output should be energized, measure contact resistance using an ohm meter.</li> <li>– Verify that wiring from output is not open.</li> <li>– Using EQ Safety System Software, verify that logic is trying to operate the channel.</li> </ul>
Serial links are not responding	<ul style="list-style-type: none"> <li>– Faulty wiring.</li> <li>– Incorrect serial link configuration.</li> <li>– Text display shows "Invalid Configuration"</li> </ul>	<ul style="list-style-type: none"> <li>– Check that P8 and P9 are fully inserted.</li> <li>– Verify that communication LEDs are flashing.</li> <li>– Verify that serial link configuration matches the host device.</li> <li>– Verify that wiring is not open or shorted.</li> </ul>
Ethernet link are not responding	<ul style="list-style-type: none"> <li>– Faulty wiring.</li> <li>– Incorrect Ethernet link configuration.</li> <li>– Text display shows "Invalid Configuration"</li> </ul>	<ul style="list-style-type: none"> <li>– Check that P3 and P4 are fully inserted.</li> <li>– Verify that communication LEDs are flashing.</li> <li>– Verify that Ethernet link configuration is correct.</li> <li>– Verify that wiring is not open or shorted.</li> </ul>
Front panel push buttons are not working	<ul style="list-style-type: none"> <li>– Power OFF.</li> <li>– Controller is faulted.</li> </ul>	<ul style="list-style-type: none"> <li>– Verify that power is present and P1 is fully inserted.</li> <li>– Cycle power to controller.</li> </ul>
Text display indicates a RTC Fault	Power loss for more than 12 hours	<ul style="list-style-type: none"> <li>– Using the Safety System Software, execute "Set RTC", which downloads the current time into the Controller's real time clock. Alternatively, use the "Set Time and Date" menu in the Controller.</li> </ul>
Hardware memory fault	Device on the LON system with a ground fault	<ul style="list-style-type: none"> <li>– This condition indicates a wiring issue in which the alarm will override status. Requires a controller reset.</li> </ul>

## ORDERING INFORMATION

When ordering, please specify:

### Refer to the appropriate model matrix in Appendix G for the following devices:

EQ3XXX EQP Controller  
EQ3700DCIO Discrete Input/Output Module  
EQ3710AIM Analog Input Module  
EQ3720RM Relay Module  
EQ3730EDIO Enhanced Discrete Input/Output Module

## POWER SUPPLIES

Part Number	Description
006979-001	EQ21xxPSM Power Supply Monitor
000604-013	EQ2110PS Power Supply (10 A / 60 Hz)
000604-014	EQ2130PS Power Supply (30 A / 60 Hz)
000604-015	EQ2175PS Power Supply (75 A / 60 Hz)
000604-035	EQ2131PS Power Supply (30 A / 50 Hz)
000604-036	EQ2176PS Power Supply (75 A / 50 Hz)
007941-001	EQ2220GFM Ground Fault Monitor
010988-001	EQP2120PS-B Power Supply, 20A/50-60 Hz, Panel Mount
010988-002	EQP2120PS Power Supply, 20A/50-60 Hz, DIN Rail Mount
010892-001	EQ2410PS-P Converter, 10A/24 Vdc, Panel Mount
010892-002	EQ2410PS Converter, 10A/24 Vdc, DIN Rail Mount
009934-001	Diode Redundancy Module, with Mounting Bracket
009934-002	Diode Redundancy Module, DIN Rail Mount

## LON DEVICES

Part Number	Description
006607-xxx	EQ22xxDCU Digital Communication Unit (specify gas)
006941-xxx	EQ24xxNE Network Extender
009183-xxx	EQ24XXPLR Physical Layer Repeater
008056-001	HART Interface Module
008982-001	EQ3LTM LON Termination Module
UD10A5M28XX	UD10-DCU Universal Display with LON interface board

## REDUNDANCY

Part Number	Description
008981-001	Controller to Controller High-Speed Serial Link Cable (4 ft)
008982-001	EQ3LTM LON Termination Module

## CONTROLLER COMMUNICATION CABLES

Part Number	Description
007633-001	Controller RS-232 Cable, DB9 Female PC Connection, 15 ft. (4.57 m)
007633-002	Controller RS-232 Cable, DB9 Female PC Connection, 30 ft. (9.14 m)
007633-003	Controller RS-232 Cable, DB9 Female PC Connection, 50 ft. (15.24 m)

## Section 6 Specifications

### NOTE

*For USCG Approved System specifications, refer to Appendix D.*

### EQ3XXX CONTROLLER

#### INPUT VOLTAGE—

24 vdc nominal, 18 to 30 Vdc. 10% overvoltage will not cause damage to the equipment.

#### INPUT POWER—

9 watts nominal, 12 watts maximum.

#### LON COMMUNICATION—

Digital communication, transformer isolated (78.5 kbps).

#### RS-485 COMMUNICATION—

Modbus Master/Slave capability. Digital communication, transformer isolated (up to 115 kbps).

#### RS-232 COMMUNICATION—

S<sup>3</sup> configuration only. Digital communication, optically isolated.

#### CONTROLNET—

Digital communication, transformer isolated (5 Mbps).

#### ETHERNET DLR—

10/100 Mbps Ethernet DLR capability.

#### ETHERNET INTERFACE BOARD—

**RS-485 Communication:** Modbus master/slave capability, ground fault monitored. Digital communication, transformer isolated (up to 230 kbps).

**10/100 Mbps BASE-T Ethernet Communication:**

Modbus TCP master/slave or S<sup>3</sup> configuration capability.

**10/100 Mbps BASE-T Ethernet Communication:**

Modbus TCP master/slave capability.

**High Speed Serial Link (HSSL):** Port used only for redundant controller to controller communication.

#### SERIAL INTERFACE BOARD—

**RS-485 Communication:** Modbus master/slave capability, ground fault monitored. Digital communication, transformer isolated (up to 230 kbps).

**RS-232 Communication:** Modbus master/slave or S<sup>3</sup> configuration capability. Digital communication, non-isolated (up to 230 kbps).

**RS-232 Communication:** Modbus master/slave capability. Digital communication, non-isolated (up to 230 kbps).

**High Speed Serial Link (HSSL):** Port used only for redundant controller to controller communication.

#### UNSUPERVISED OUTPUTS—

Dry Contact Rating: 1 ampere at 30 Vdc maximum. SPDT normally open/normally closed contact, Configurable for normally energized or de-energized (de-energized is the default mode).

#### UNSUPERVISED INPUTS—

Two State input (on/off). User selectable normally open or normally closed contact (N.O. is the default).

#### TROUBLE OUTPUT—

SPDT normally open/normally closed contact, Non-Configurable, normally energized only.

#### TEMPERATURE RANGE—

Operating (Certified Rating): See Certification section below.  
Storage: -40°F to +185°F (-40°C to +85°C). Excluding communication port optional modules.

#### HUMIDITY RANGE—

5 to 95% RH, non-condensing.

#### VIBRATION—

FM 3260, FM 6310/6320.

#### DIMENSIONS—

See Figure 6-1.

#### SHIPPING WEIGHT—

5 pounds (2.3 kilograms).

**CERTIFICATION—**

FM / CSA: Class I, Div. 2, Groups A, B, C, D (T4).

Class I, Zone 2, Group IIC (T4).

Tamb = -40°C to +80°C.

Performance verified.

Refer to Appendix A for FM Approval details, including Protected Premises Fire Alarm Systems and EQP Supervising Systems.

Refer to Appendix B for CSA Certification details.

Refer to Appendix D for USCG Approval details.

CE: ATEX/EMC Directive Compliant.



ATEX: Ex II 3 G.

Ex nAc nCc IIC T4.

EN 60079-29-1 & EN 60079-29-4.

DEMKO 02 ATEX 133867X.

Tamb\* = -40°C to +80°C.

Tamb = -40°C to +70°C.

IECEX: IECEx ULD 10.0004X.

Ex nAc nCc IIC T4.

Tamb\* = -40°C to +80°C.

Tamb = -40°C to +70°C.

Note: Refer to Appendix C for ATEX and IECEx approval details and Special Conditions for Safe Use.

\*Applicable only if relays 1-7 (terminals 21-41) are configured such that the relay contacts are normally open and de-energized (refer to Figures 3-8 and 3-9 for relay wiring information).

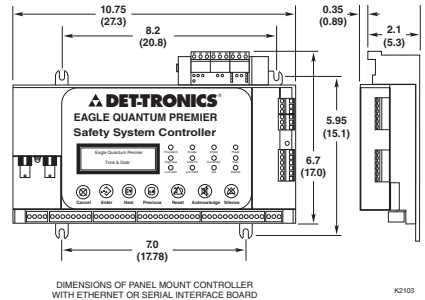
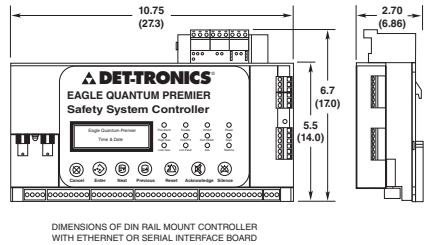
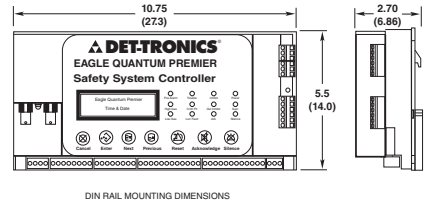
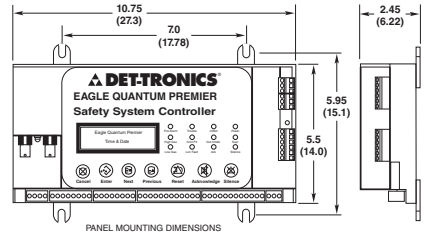

Figure 6-1—Dimensions of EQP Controller in Inches (Centimeters)



## EQ3LTM LON TERMINATION MODULE

### INPUT VOLTAGE—

24 Vdc nominal, 18 to 30 Vdc. 10% overvoltage will not cause damage to the equipment.

### INPUT POWER—

1 watt maximum.

### TEMPERATURE RANGE—

Operating:  $-40^{\circ}\text{F}$  to  $+185^{\circ}\text{F}$  ( $-40^{\circ}\text{C}$  to  $+85^{\circ}\text{C}$ ).  
Storage:  $-67^{\circ}\text{F}$  to  $+185^{\circ}\text{F}$  ( $-55^{\circ}\text{C}$  to  $+85^{\circ}\text{C}$ ).

### HUMIDITY RANGE—

5 to 95% RH, non-condensing.

### DIMENSIONS—

See Figure 6-2.

### SHIPPING WEIGHT—

0.5 pounds (0.2 kilograms)

### CERTIFICATION—

FM / CSA: Class I, Div. 2, Groups A, B, C, D (T4).  
Class I, Zone 2, Group IIC (T4).

Refer to Appendix A for FM Approval details.  
Refer to Appendix B for CSA Approval details.

CE: ATEX/EMC Directive Compliant.



ATEX:

II 3 G.



Ex nA IIC T4 Gc.  
DEMKO 04 ATEX 138345X.  
Tamb =  $-40^{\circ}\text{C}$  to  $+85^{\circ}\text{C}$ .

IECEX:

IECEX ULD 10.0004X.



Ex nA IIC T4 Gc.  
Tamb =  $-40^{\circ}\text{C}$  to  $+85^{\circ}\text{C}$ .

Note: Refer to Appendix C for ATEX and IECEX approval details and Special Conditions for Safe Use.

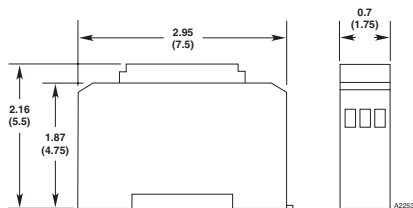

Figure 6-2—Dimensions of LON Termination Module and HART Interface Module in Inches (Centimeters)

## EQ3730EDIO ENHANCED DISCRETE INPUT/OUTPUT MODULE

### POWER REQUIREMENTS—

Module Power Consumption: 3 watts nominal, 11 watts maximum.

### INPUT/OUTPUT VOLTAGE—

24 Vdc nominal, 18 to 30 Vdc. 10% overvoltage will not cause damage to the equipment.

Note: Pre-action and deluge applications further limit the lower operating voltage range, refer to EDIO installation instructions in section 3.

### OUTPUT CURRENT—

10.0 amperes maximum total current, 2.0 amperes maximum per channel.

### SLC OUTPUT—

Digital communication, transformer isolated (78.5 kbps).

### TEMPERATURE RANGE—

Operating:  $-40^{\circ}\text{F}$  to  $+185^{\circ}\text{F}$  ( $-40^{\circ}\text{C}$  to  $+85^{\circ}\text{C}$ ).  
Storage:  $-67^{\circ}\text{F}$  to  $+185^{\circ}\text{F}$  ( $-55^{\circ}\text{C}$  to  $+85^{\circ}\text{C}$ ).

### HUMIDITY RANGE—

5% to 95% RH, non-condensing.

### VIBRATION—

FM 3260-2000 (clause 4.9).

### DIMENSIONS—

Refer to Figure 6-3.

### SHIPPING WEIGHT—

1 pound (0.45 kilograms).

### CERTIFICATION—

FM / CSA: Class I, Div. 2, Groups A, B, C, D (T4).  
Class I, Zone 2, Group IIC (T4).

Refer to Appendix A for FM Approval details.  
Refer to Appendix B for CSA Approval details.



ATEX/EMC Directive Compliant.



II 3 G.

Ex nA nC IIC T4 GC EN 60079-29-1.  
DEMKO 05 ATEX 138864X.  
Tamb =  $-40^{\circ}\text{C}$  to  $+85^{\circ}\text{C}$ .

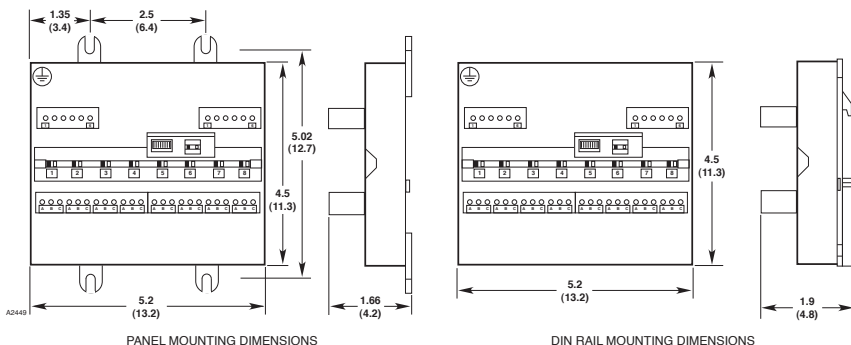

Figure 6-3—Dimensions of the EDIO / DCIO / Relay Module / AIM in Inches (Centimeters)

IECEX: IECEX ULD 10.0004X.  
 Ex nA nC IIC T4 GC.  
 Tamb = -40°C to +85°C.

Note: Refer to Appendix C for ATEX and IECEX approval details and Special Conditions for Safe Use.

Refer to Appendix D for USCG Approval details.

### INPUT / INITIATING DEVICE CIRCUITS

#### UNSUPERVISED INPUT—

Two state input (on/off).  
 Normally open contact.

#### SUPERVISED INPUT (OPEN CIRCUIT)—

For Class A and Class B wiring.

Two state input (active/trouble):

- End of Line Resistor 10 K ohms nominal
- Open Circuit > 45 K ohms
- Active Circuit < 5 K ohms.

#### SUPERVISED INPUT (OPEN AND SHORT CIRCUIT)—

For Class A and Class B wiring.

Three State input (active/short/open):

- End of Line Resistor 10 K ohms nominal
- In Line Resistor 3.3 K ohms nominal
- Open Circuit > 45 K ohms
- Short Circuit < 250 ohms
- Active Circuit 2.5 K ohms to 5 K ohms.

#### INPUT, TYPES—

Configurable for static logic applications:

- Fire Alarm
- Supervisory
- Trouble
- High Gas Alarm
- Low Gas Alarm
- Other.

For Class A wiring on inputs, configure adjacent channels for Class A wiring and connect both channels to single contact device(s).

### INPUT CIRCUITS – TWO WIRE SMOKE/HEAT TYPE—

Supervised Input, Class B:

Up to 15 two wire detectors per circuit.

Maximum line resistance 50 ohms.

5K ohm EOL.

Open circuit fault impedance 22k ohms.

### OUTPUT / NOTIFICATION / RELEASING OR UNSUPERVISED DEVICE CIRCUITS

#### UNSUPERVISED OUTPUT RATING

(Per Channel)—

2 amperes at 30 Vdc maximum.

Automatic short circuit protection provided.

Instantaneous short circuit current < 15 amperes.

Note: Voltage available at outputs is dependent on input voltage ( $V_{out} \approx V_{in} - 0.5 \text{ Vdc}$ ).

#### OUTPUT STYLE—

Form "A" normally off.

#### RESPONSE TIME—

Output actuates in <0.15 second after acknowledging an alarm command message.

## **SUPERVISED OUTPUT RATING-SIGNALING CIRCUIT**

### **MAXIMUM OUTPUT CURRENT**

(Per Channel)—

2 amperes at 30 Vdc maximum.

Automatic short circuit protection provided.

Instantaneous short circuit current < 15 amperes.

### **SUPERVISORY CURRENT (Per Channel)—**

Reverse current monitored at 1.5 mA,  $\pm$  0.5 mA.

### **RESPONSE TIME—**

Output actuates in <0.15 second after acknowledging an alarm command message.

### **EOL RESISTORS—**

10 K ohms  $\pm$ 2 K ohms. Each circuit must have an EOL resistor.

### **SIGNALING OUTPUT, TYPES—**

Configurable for device applications:

- Continuous
- 60 beats per minute
- 120 beats per minute
- Temporal Pattern.

Note: All eight channels are synchronized when programmed as a signaling output.

## **SUPERVISED OUTPUT RATING-RELEASING CIRCUIT**

### **MAXIMUM OUTPUT CURRENT**

(Per Channel)—

2 amperes at 30 Vdc maximum.

Automatic short circuit protection provided.

Instantaneous short circuit current < 15 amperes.

### **SUPERVISORY CURRENT (Per Channel)—**

Monitored at 1.3 mA  $\pm$ 0.2 mA.

### **RESPONSE TIME—**

Output actuates in <0.15 second after acknowledging an alarm command message.

### **RELEASING OUTPUT, TYPES—**

Configurable for device applications:

- Continuous
- Timed.

For Class A wiring on outputs, configure adjacent channels for Class A wiring and connect both channels to single output device(s).

## **NOTE**

*EDIO SIL has the capability of monitoring solenoid circuits for shorts. The minimum solenoid inductance for correct operation is 100 mH. See Table 3-10 for a list of recommended solenoids.*

## **EQ3700 DISCRETE IO (DCIO) MODULE**

### **POWER REQUIREMENTS—**

3 watts nominal, 11 watts maximum.

### **INPUT VOLTAGE—**

24 vdc nominal, 18 to 30 Vdc. 10% overvoltage will not cause damage to the equipment.

NOTE: Pre-action and deluge applications further limit the lower operating voltage range, refer to DCIO installation instructions in section 3.

### **OUTPUT VOLTAGE—**

(Input voltage - 0.5 Vdc) @ 2 amperes.

### **OUTPUT CURRENT—**

10.0 amperes maximum total current, 2.0 amperes maximum per channel.

### **LON COMMUNICATION—**

Digital communication, transformer isolated (78.5 kbps).

### **TEMPERATURE RANGE—**

Operating: -40°F to +185°F (-40°C to +85°C).  
Storage: -67°F to +185°F (-55°C to +85°C).

### **HUMIDITY RANGE—**

5 to 95% RH, non-condensing.

### **DIMENSIONS—**

Refer to Figure 6-3.

### **SHIPPING WEIGHT—**

1 pound (0.45 kilograms).

### **CERTIFICATION—**

FM / CSA: Class I, Div. 2, Groups A, B, C, D (T4).  
  Class I, Zone 2, Group IIC (T4).

Refer to Appendix A for FM Approval details.

Refer to Appendix B for CSA Approval details.

CE: ATEX/EMC Directive Compliant.



ATEX:  II 3 G.  
Ex nA nC IIC T4 Gc.  
DEMKO 02 ATEX 133864X.  
Tamb = -40°C to +85°C.

IECEX:  IECEx ULD 10.0004X.  
Ex nA nC IIC T4 Gc.  
Tamb = -40°C to +85°C.

Note: Refer to Appendix C for ATEX and IECEx approval details and Special Conditions for Safe Use.

## INPUT / INITIATING DEVICE CIRCUITS

### UNSUPERVISED INPUT—

Two state input (on/off).  
Normally open contact.

### SUPERVISED INPUT, CLASS B—

Two state input (active/trouble):

- End of Line Resistor 10 K ohms nominal
- Open Circuit > 45 K ohms
- Active Circuit < 5 K ohms.

### SUPERVISED INPUT, CLASS B—

Three State input (active/short/open):

- End of Line Resistor 10 K ohms nominal
- In Line Resistor 3.3 K ohms nominal
- Open Circuit > 45 K ohms
- Short Circuit < 1.4 K ohms
- Active Circuit 2.5 K ohms to 5 K ohms.

### INPUT, TYPES—

Configurable for fixed logic applications:

- Fire Alarm
- Supervisory
- Trouble
- High Gas Alarm
- Low Gas Alarm
- Other.

## OUTPUT / NOTIFICATION / RELEASING CIRCUITS

### UNSUPERVISED OUTPUT RATING—

Short circuit protected: 2 amperes at 30 Vdc maximum.

### SUPERVISED OUTPUT RATING— SIGNALING CIRCUIT

### MAXIMUM OUTPUT CURRENT—

2 amperes maximum, 15 Amp inrush.  
Automatic short circuit protection provided.

### SUPERVISORY CURRENT—

Reverse current monitored at 3.0 mA, ± 2.0 mA.

### RESPONSE TIME—

Output actuates in <0.15 second after acknowledging an alarm command message.

### EOL RESISTORS—

10 K ohms ±2 K ohms.

### SIGNALING OUTPUT, TYPES—

Configurable for device applications:

- Continuous
- 60 beats per second
- 120 beats per second
- Temporal Pattern.

### NOTE

*All eight channels are synchronized when programmed as a signaling output.*

### SUPERVISED OUTPUT RATING— RELEASING CIRCUIT

### MAXIMUM OUTPUT CURRENT (Per Channel)—

2 amperes maximum, 15 Amp inrush.  
Automatic short circuit protection provided.

### SUPERVISORY CURRENT—

Monitored at 3.0 mA ±2.0 mA.

### RESPONSE TIME—

Output actuates in <0.15 second after acknowledging an alarm command message.

### RELEASING OUTPUT, TYPES—

Configurable for device applications:

- Continuous
- Timed.

## EQ3720 RELAY MODULE

### POWER REQUIREMENTS—

3 watts nominal, 4 watts maximum.

### INPUT VOLTAGE—

24 Vdc nominal, 18 to 30 Vdc. 10% overvoltage will not cause damage to the equipment.

### RELAY CONTACTS—

30 Vdc, 1 amps resistive.

### LON COMMUNICATION—

Digital communication, transformer isolated (78.5 kbps).

### TEMPERATURE RANGE—

Operating:  $-40^{\circ}\text{F}$  to  $+185^{\circ}\text{F}$  ( $-40^{\circ}\text{C}$  to  $+85^{\circ}\text{C}$ ).  
Storage:  $-67^{\circ}\text{F}$  to  $+185^{\circ}\text{F}$  ( $-55^{\circ}\text{C}$  to  $+85^{\circ}\text{C}$ ).

### HUMIDITY RANGE—

5 to 95% RH, non-condensing.

### DIMENSIONS—

Refer to Figure 6-3.

### SHIPPING WEIGHT—

1 pound (0.45 kilograms).

### CERTIFICATION—

FM / CSA: Class I, Div. 2, Groups A, B, C, D (T3C).  
Class I, Zone 2, Group IIC (T3).

Refer to Appendix A for FM Approval details.  
Refer to Appendix B for CSA Approval details.  
Refer to Appendix D for USCG Approval details.

CE: ATEX/EMC Directive Compliant.



ATEX: II 3 G.  
Ex nA nC IIC T3 Gc.  
DEMKO 03 ATEX 135246X.  
Tamb =  $-40^{\circ}\text{C}$  to  $+75^{\circ}\text{C}$ .

IECEX: IECEx ULD 10.0004X.  
Ex nA nC IIC T3 Gc.  
Tamb =  $-40^{\circ}\text{C}$  to  $+75^{\circ}\text{C}$ .



Note: Refer to Appendix C for ATEX and IECEx approval details and Special Conditions for Safe Use.

### RESPONSE TIME—

Actuates in <0.15 second after acknowledging an alarm command message.

## EQ3710AIM ANALOG INPUT MODULE

### POWER REQUIREMENTS—

6 watts nominal, 8 watts maximum.

### INPUT/OUTPUT VOLTAGE—

24 Vdc nominal, 18 to 30 Vdc. 10% overvoltage will not cause damage to the equipment.

### TEMPERATURE RANGE—

Operating:  $-40^{\circ}\text{F}$  to  $+185^{\circ}\text{F}$  ( $-40^{\circ}\text{C}$  to  $+85^{\circ}\text{C}$ ).  
Storage:  $-67^{\circ}\text{F}$  to  $+185^{\circ}\text{F}$  ( $-55^{\circ}\text{C}$  to  $+85^{\circ}\text{C}$ ).

### HUMIDITY RANGE—

0 to 95% RH, non-condensing.

### CHANNEL ACCURACY—

See accuracy specification of connected product.

### RESPONSE TIME—

1 to 100 LON devices: < 2 seconds  
101 to 200 LON devices: < 3 seconds  
201 to 246 LON devices: < 4 seconds

### LON COMMUNICATION—

Digital communication, transformer isolated (78.5 kbps).

### DIMENSIONS—

Refer to Figure 6-3.

### SHIPPING WEIGHT—

1 pound (0.45 kilograms).

### CERTIFICATION—

FM / CSA: Class I, Div. 2, Groups A, B, C, D (T4).  
Class I, Zone 2, Group IIC (T4).

Refer to Appendix A for FM Approval details.  
Refer to Appendix B for CSA Approval details.

CE: ATEX/EMC Directive Compliant.

ATEX: II 3 G.  
Ex nA nC IIC T4 Gc EN60079-29-1.  
DEMKO 03 ATEX 136207X.  
Tamb =  $-40^{\circ}\text{C}$  to  $+85^{\circ}\text{C}$ .



IECEX: IECEx ULD 10.0004X.  
Ex nA nC IIC T4 Gc.  
Tamb =  $-40^{\circ}\text{C}$  to  $+85^{\circ}\text{C}$ .

Note: Refer to Appendix C for ATEX and IECEx approval details and Special Conditions for Safe Use.



Refer to Appendix D for USCG Approval details.

## EQ21XXPS POWER SUPPLIES

### HART INTERFACE MODULE (HIM)

#### INPUT VOLTAGE—

24 vdc nominal, 18 to 30 Vdc. 10% overvoltage will not cause damage to the equipment.

#### INPUT POWER—

1.0 watt maximum.

#### INPUT/OUTPUT CURRENT—

Operating: 4 -20 mA.

Maximum: 0-30 mA.

#### TEMPERATURE RANGE—

Operating: -40°F to +185°F (-40°C to +85°C).

Storage: -67°F to +185°F (-55°C to +85°C).

#### HUMIDITY RANGE—

5 to 95% RH, non-condensing.

#### DIMENSIONS—

See Figure 6-2.

#### SHIPPING WEIGHT—

0.5 pounds (0.2 kilograms)

#### CERTIFICATION—

FM / CSA: Class I, Div. 2, Groups A, B, C, D (T4).  
Class I, Zone 2, Group IIC (T4).

CE: ATEX/EMC Directive Compliant.



ATEX II 3 G.

Ex nA IIC T4 Gc.



DEMKO 04 ATEX 136507X.

Tamb = -40°C to +85°C.

IECEx: IECEx ULD 10.0004X.



Ex nA IIC T4 Gc.

Tamb = -40°C to +85°C.

Note: Refer to Appendix C for ATEX and IECEx approval details and Special Conditions for Use.



#### INPUT VOLTAGE—

Selectable for 120, 208 or 240 vac input power, ±10%.

#### INPUT CURRENT—

60 Hz Models:

EQ2110PS: 4 amps at 120 VAC

EQ2130PS: 11 / 6 / 6 amps at 120 / 208 / 240 VAC

EQ2175PS: 24 / 15 / 12 amps at 120 / 208 / 240 VAC.

50 Hz Models:

EQ2111PS: 4 amps at 120 VAC

EQ2131PS: 6 amps at 240 VAC

EQ2176PS: 12 amps at 240 VAC

#### OUTPUT CURRENT—

EQ2110PS / EQ2111PS: 10 amperes at 24 Vdc

EQ2130PS / EQ2131PS: 30 amperes at 24 Vdc

EQ2175PS / EQ2176PS: 75 amperes at 24 Vdc

#### POWER CONSUMPTION—

EQ2110PS / EQ2111PS: 46 Watts

EQ2130PS / EQ2131PS: 140 Watts

EQ2175PS / EQ2176PS: 349 Watts

#### TEMPERATURE RANGE—

Operating: +32°F to +122°F (0°C to +50°C)

Storage: -40°F to +185°F (-40°C to +85°C)

#### HUMIDITY RANGE—

5 to 95% RH, non-condensing.

#### DIMENSIONS—

in Inches (Centimeters)

Width Height Depth

EQ211xPS: 19 (48.3) 7 (17.8) 15 (38.1)

EQ213xPS: 19 (48.3) 14 (35.6) 15 (38.1)

EQ217xPS: 19 (48.3) 14 (35.6) 15 (38.1)

#### NOTE

*Power supplies are designed for mounting in a standard 19 inch rack. Optional mounting hardware is available for floor or wall mount applications.*

#### CERTIFICATION—

FM / CSA: Ordinary locations.

## EQP2XX0PS(-X) POWER SUPPLIES

### INPUT VOLTAGE—

EQP2120PS(-B): Auto selectable for 120/220 Vac, -15%, +10%; 60/50 Hz, single phase;  
EQP2410PS(-P) Converter: 24 Vdc, -15%, +10%.

### INPUT CURRENT—

EQP2120PS(-B): 6.6 A max @ 120 Vac  
3.6 A max @ 220 Vac  
EQP2410PS(-P): 15.7 A @ max @ 24 Vdc

### OUTPUT VOLTAGE—

24.5 Vdc nominal, 24.5 to 28.0 Vdc.

### OUTPUT CURRENT—

EQP2120PS(-B): 20 A  
EQP2410PS(-P): 10 A

### TEMPERATURE RANGE (ALL MODELS)—

Operating: -13°F to +131°F (-25°C to +55°C)  
(All Applications)  
Storage: -40°F to +185°F (-40°C to +85°C)

### HUMIDITY RANGE—

5 to 95% RH at 25°C, non-condensing.

### DIMENSIONS—

In Inches (Centimeters)

	Width	Height	Depth
EQP2120PS(-B):	3.54(9)	5.2(13.0)	5.0(12.5)
EQP2410PS(-P):	3.2(8.0)	5.2(13.0)	5.0(12.5)

### NOTE

*Power supplies are designed for DIN rail or panel mounting (-B or -P suffix).*

### CERTIFICATION—

FM / CSA: Ordinary locations.  
USCG: Refer to Appendix D for details.

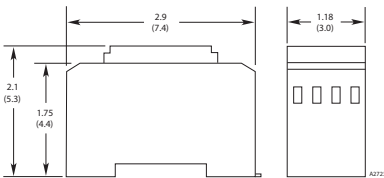

Figure 6-4—Dimensions of EQ2230RSP Module in Inches (CM)

## REDUNDANCY MODULE QUINT-DIODE/40

### TEMPERATURE RANGE—

Operating: -13°F to +131°F (-25°C to +55°C)  
(All Applications)  
Storage: -40°F to +185°F (-40°C to +85°C).

### HUMIDITY RANGE—

5 to 95% RH, non-condensing.

### DIMENSIONS—

in Inches (Centimeters)

Width	Height	Depth
2.4 (6.2)	4 (10.2)	3.3 (8.4)

## EQ2230RSP MODULE

### INPUT VOLTAGE—

24 Vdc nominal, 18 to 30 Vdc. 10% overvoltage will not cause damage to the equipment.

### TEMPERATURE RANGE—

Operating: -40°F to +185°F (-40°C to +85°C).  
Storage: -67°F to +185°F (-55°C to +85°C).

### HUMIDITY RANGE—

5 to 95% RH, non-condensing.



### DIMENSIONS—

See Figure 6-4.

### SHIPPING WEIGHT—

0.5 pounds (0.2 kilograms)

### CERTIFICATION—

FM / CSA: Class I, Div. 2, Groups A, B, C, D (T4).  

 Class I, Zone 2, Group IIC (T4).

### CE:

ATEX/EMC Directive Compliant.



### ATEX



Ex II 3 G.  
Ex nA IIC T4 Gc.  
DEMKO Q2 ATEX 133867X.  
T<sub>amb</sub> = -40°C to +85°C.

### IECEX:



IECEX ULD 10.0004X.  
Ex nA IIC T4 Gc.  
T<sub>amb</sub> = -40°C to +85°C.

Note: Refer to Appendix C for ATEX and IECEx approval details and Special Conditions for Safe Use.

## EQ21XXPSM POWER SUPPLY MONITOR

### INPUT VOLTAGE—

24 Vdc nominal, 18 to 30 Vdc.

### POWER CONSUMPTION—

2.0 watts maximum.

### MEASUREMENT RANGE—

AC Voltage: 240 vac maximum.

DC Battery Charging Current: 75 amperes maximum.

### OUTPUT—

Digital communication, transformer isolated (78.5 k bps).

### TEMPERATURE RANGE—

Operating: +32°F to +122°F (0°C to +50°C)

Storage: -67°F to +185°F (-55°C to +85°C).

### HUMIDITY RANGE—

5 to 95% RH, non-condensing.

### DIMENSIONS—

See Figure 6-5.

### CERTIFICATION—

FM / CSA: Ordinary locations.

## EQ2220GFM GROUND FAULT MONITOR

### INPUT VOLTAGE—

24 Vdc nominal, 18 to 30 Vdc. 10% overvoltage will not cause damage to the equipment.

### INPUT POWER—

1.0 watt maximum.

### OUTPUT—

Form C NO/NC relay contact rated 1 ampere (resistive) at 30 Vdc maximum.

### TEMPERATURE RANGE—

Operating: -40°F to +185°F (-40°C to +85°C).

Storage: -67°F to +185°F (-55°C to +85°C).

### HUMIDITY RANGE—

5 to 95% RH, non-condensing.

### DIMENSIONS—

See Figure 6-6.

### SHIPPING WEIGHT—

0.5 pounds (0.2 kilograms)

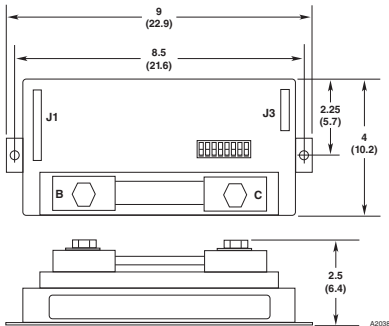

Figure 6-5—Dimensions of Power Supply Monitor in Inches (CM)



**CERTIFICATION—**

FM / CSA: Class I, Div. 2, Groups A, B, C, D (T4).  
Class I, Zone 2, Group IIC (T4).



Refer to Appendix A for FM Approval details.  
Refer to Appendix B for CSA Approval details.

CE: ATEX/EMC Directive Compliant.



ATEX: II 3 G  
Ex nA nC IIC T4 Gc  
DEMKO 03 ATEX 136222X  
Tamb = -40°C to +85°C



IECEX: IECEX ULD 10.0004X  
Ex nA nC IIC T4 Gc  
Tamb = -40°C to +85°C



Note: Refer to Appendix C for ATEX Approval and Appendix E for CE Mark details and Special Conditions for Safe Use.

Refer to Appendix D for USCG Approval details.

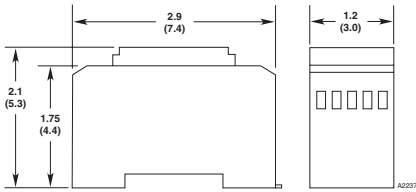

Figure 6-6—Dimensions of Ground Fault Monitor in Inches (Centimeters)

**EQ22XXDCU AND EQ22XXDCUEX DIGITAL COMMUNICATION UNIT**

**INPUT VOLTAGE—**

24 Vdc nominal, 18 to 30 Vdc. 10% overvoltage will not cause damage to the equipment.

**POWER CONSUMPTION—**

DCU with toxic gas sensor/transmitter: 95 mA max.

DCU with transmitter and combustible gas sensor: 180 mA maximum during normal operation, 500 mA during startup.

**INPUTS—**

4–20 mA analog signal, non-intrusive calibration.

**OUTPUTS—**

Digital communication, transformer isolated (78.5 kbps).

**TEMPERATURE RANGE—**

Operating: -40°F to +167°F (-40°C to +75°C).  
Storage: -67°F to +185°F (-55°C to +85°C).

**HUMIDITY RANGE—**

5 to 95% RH, non-condensing.

**VIBRATION—**

FM 6310/6320.

**DIMENSIONS—**

See Figure 6-7.

## CERTIFICATION—

FM / CSA: Class I, Div. 1, Groups B, C, D.  
Class I, Zone 1, Group IIC.  
Class I, Div. 2, Groups A, B, C, D (T4).  
Class I, Zone 2, Group IIC (T4).  
Class II/III, Div. 1 & 2 (for use with Model STB).  
NEMA/Type 4X (for use with Model STB).



Refer to Appendix A for FM Approval details.  
Refer to Appendix B for CSA Approval details.

ATEX: 0539 Ex II 2 G  
Ex db IIC T6...T4 EN 60079-29-1  
DEMKO 02 ATEX 131321X  
T6 (Tamb = -55°C to +50°C)  
T5 (Tamb = -55°C to +65°C)  
T4 (Tamb = -55°C to +75°C)  
IP66



Refer to Appendix C for ATEX Approval details.

## Special Conditions for Safe Use (X):

The device has an ambient temperature rating for performance of -40°C to +75°C.

IEC: IECEx ULD 10.0010X  
Ex db IIC T6...T4  
T6 (Tamb = -55°C to +50°C)  
T5 (Tamb = -55°C to +65°C)  
T4 (Tamb = -55°C to +75°C)



Refer to Appendix D for USCG Approval details.

Refer to Appendix E for CE Mark details.

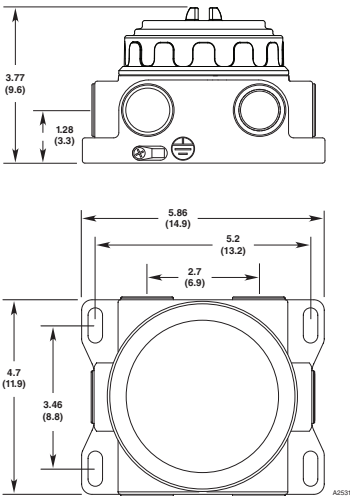

Figure 6-7—Dimensions of Short Cover Junction Box in Inches (Centimeters)

# EQ24XXNE NETWORK EXTENDER

## INPUT VOLTAGE—

24 Vdc nominal, 18 to 30 Vdc. 10% overvoltage will not cause damage to the equipment.

## POWER CONSUMPTION—

2.2 watts nominal at 24 Vdc, 2.7 watts maximum.

## INPUTS/OUTPUTS—

Digital, transformer isolated (78.5k Baud).

## TEMPERATURE RANGE—

Operating: -40°F to +167°F (-40°C to +75°C)  
Storage: -67°F to +185°F (-55°C to +85°C).

## HUMIDITY—

5 to 95% RH at 70°C.

## DIMENSIONS—

See Figure 6-7.

## CERTIFICATION—

FM / CSA: Class I, Div. 1, Groups B, C, D.  
Class I, Zone 1, Group IIC.  
Class II/III, Div. 1, Groups E, F, G.  
Class I, Div. 2, Groups A, B, C, D (T4).  
Class I, Zone 2, Group IIC (T4).  
Class II/III, Div. 2, Groups F & G (T4).  
NEMA/Type 4X.

Refer to Appendix A for FM Approval details.  
Refer to Appendix B for CSA Approval details.

CE: ATEX/EMC Directive Compliant.



ATEX: Ex II 2 G.  
Ex db IIC T6...T4 EN 60079-29-1  
DEMKO 02 ATEX 131321X  
T6 (Tamb = -55°C to +50°C)  
T5 (Tamb = -55°C to +65°C)  
T4 (Tamb = -55°C to +75°C)  
IP66

Refer to Appendix C for ATEX Approval details.

IEC: IECEx ULD 10.0010X  
Ex db IIC T6...T4  
T6 (Tamb = -55°C to +50°C)  
T5 (Tamb = -55°C to +65°C)  
T4 (Tamb = -55°C to +75°C)



Refer to Appendix D for USCG Approval details.  
Refer to Appendix E for CE Mark details.

## **EQ3750 ASH ADDRESSABLE SMOKE & HEAT MODULE**

For complete information regarding the ASH Module, refer to instruction manual number 95-8654.

## **EQ3760ASM ADDRESSABLE SMOKE MODULE**

For complete information regarding the ASM Module, refer to instruction manual number 95-8755.

## **EQ3780HSDM HIGH SPEED DELUGE MODULE**

For complete information regarding the HSDM Module, refer to instruction manual number 95-8782.

## **COMBUSTIBLE GAS SENSOR**

Refer to the Combustible Gas Sensor Specification Data sheet, form 90-1041, for specifications.

## **ELECTROCHEMICAL SENSORS**

Refer to the Electrochemical Gas Sensor Specifications in the UD10-DCU manual 95-8656 and EQ22xxDCU Specification Data 90-1118 for additional information.

## **UD10-DCU UNIVERSAL DISPLAY**

For complete information regarding the UD10-DCU, refer to Specification Data Sheet 90-1200 and instruction manual number 95-8656.

## **EQ21XXPS POWER SUPPLY**

The EQ21xxPS Rectifier / Power Supply has many inherent advantages such as voltage regulation, high efficiency, high power factor and short circuit protection.

These chargers provide separate adjustable voltages for floating or equalizing lead or nickel-cadmium cells. An equalize switch is located on the front panel of the charger for manual activation or a multi-mode electronic timer can be used for automatic activation.

Steady state output voltage remains within +/- 1/2% of the setting from no load to full load and for AC input voltages within +/- 10% of the nominal input voltage. The power supply is internally filtered to be no greater than 32dBrn ("C" message weighting) and 30 millivolts RMS for all conditions on input voltage and output load with or without batteries connected. This allows the A36D to be used as a battery eliminator.

## Section 7 Ordering Information

### CONTROLLER MODEL MATRIX

MODEL	DESCRIPTION	
EQ3001	EQP Controller - 246 Nodes	
EQ3016	EQP Controller - 16 Nodes	
	TYPE	MOUNTING OPTION
	D	Din Rail
	P	Panel Mount
	TYPE	COM BOARD 1
	N	None
	C	ControlNet
	D	Ethernet DLR
	TYPE	COM BOARD 2
	N	None
	E	Ethernet Port Expansion
	S	Serial Port Expansion
	TYPE	APPROVALS*
	S	SIL
	T	SIL/FM/CSA/ATEX/IECEX
	T-C	T plus US Coast Guard
	W	FM/CSA/ATEX/IECEX
	W-C	W plus US Coast Guard

\*Type "APPROVALS" can use one or more letters to designate the approvals of the product. Some configurations are not available. Check with factory for additional information.

For USCG approved controller models, refer to Appendix D.

NOTE: Contact Customer Service when ordering replacement EQ3XXX Controllers for redundant systems.

### EDIO MODEL MATRIX

MODEL	DESCRIPTION	
EQ3730	8 Channel Enhanced Discrete Input/Output (EDIO) Module	
	TYPE	MOUNTING OPTION
	D	DIN Rail
	P	Panel
	TYPE	APPROVALS*
	S	SIL
	T	SIL/FM/CSA/ATEX/IECEX
	W	FM/CSA/ATEX*/IECEX

\*Type "APPROVALS" can use one or more letters to designate the approvals of the product. Some configurations are not available. Check with factory for additional information.

## DCIO MODEL MATRIX

MODEL	DESCRIPTION	
EQ3700	8 Channel Discrete Input/Output (DCIO) Module	
	TYPE	MOUNTING OPTION
	D	DIN Rail
	P	Panel
	TYPE	APPROVALS*
W	FM/CSA/ATEX/IECEX	

\*Type "APPROVALS" can use one or more letters to designate the approvals of the product. Some configurations are not available. Check with factory for additional information.

## AIM MODEL MATRIX

MODEL	DESCRIPTION	
EQ3710	8 Channel Analog Input (AIM) Module	
	TYPE	MOUNTING OPTION
	D	Din Rail
	P	Panel
	TYPE	APPROVALS*
S	SIL	
T	SIL/FM/CSA/ATEX/IECEX	
W	FM/CSA/ATEX/IECEX	

\*Type "APPROVALS" can use one or more letters to designate the approvals of the product. Some configurations are not available. Check with factory for additional information.

## RELAY MODULE MODEL MATRIX

MODEL	DESCRIPTION	
EQ3720	8 Channel Relay Module (RM)	
	TYPE	MOUNTING OPTION
	D	Din Rail
	P	Panel
	TYPE	APPROVALS*
W	FM/CSA/ATEX/IECEX	

\*Type "APPROVALS" can use one or more letters to designate the approvals of the product. Some configurations are not available. Check with factory for additional information.

## ORDERING INFORMATION

POWER SUPPLY, DIODE, CONTROLLER, DUCT MOUNT KIT		
DEC Part Number	Model	Description
010988-001	EQP2120PS-B (Replacement)	Phoenix Contact QUINT-PS-1AC/24DC/20 Panel Mount
010892-001	EQP2410PS-P	Phoenix Contact QUINT-PS-24DC/24DC/10 Panel Mount
009934-001	Diode Redundancy Module	Phoenix Contact QUINT-DIODE/40 Panel Mount
007609-269	EQ3XXXPCSW-C	EQP System Controller, panel mount
009931-001	Q900C1001	Duct Mount Kit
000523-009	000523-009	See description on page D-6
000523-010	000523-010	See description on page D-6

For other USCG Approved EQP System components, refer to Table D-1 or contact Det-Tronics Customer Service.

Refer to Section 3 of this manual for determining power requirements.

# APPENDIX A

## FM APPROVAL DESCRIPTION

### FIRE DETECTION & RELEASING

- National Fire Alarm Code performance verified per NFPA 72®-2013. Refer to Table A-1 for device and circuit supervision characteristics.
- See section 2 "Field Devices Flame Detectors" for information regarding Det-Tronics approved flame detectors and associated manuals. Additional two second response time applied for system communication.
- I/O Modules EQ3700 DCIO series (Class B IDC/NAC), EQ3730 EDIO series (Class A or B IDC/NAC) and EQ3780HSDM series. Reference Table 3-10 for compatible solenoids used for automatic release of pre-action and deluge sprinkler and extinguishing systems.

### GAS DETECTION

FM Certificate No. FM17US0258X

- Combustible Gas Performance verified for 0 to 100% LFL methane-in-air atmospheres per FM 6320. Accuracy:  $\pm 3\%$  LFL from 0 to 50% LFL,  $\pm 5\%$  LFL from 51% to 100% LFL. For the Model PIRECL, refer to the PIRECL manual (form number 95-8526) for further FM gas performance details.

•

*NOTE: Detector Electronics combustible gas detection K factors are not FM verified.*

- H2S Toxic Gas Performance verified 0 to 20, 50 or 100 ppm per FM requirements. Accuracy:  $\pm 2$  ppm from 0 to 20 ppm,  $\pm 10\%$  of concentration from 21 to 100 ppm. Models C7064E4012 and C7064E5012 Hydrogen Sulfide (H2S) Sensors Explosion-proof for Class I, Div. 1, Groups C and D Hazardous (Classified) Locations per FM 3615. Model C7064E5014 Hydrogen Sulfide (H2S) Sensors Explosion-proof for Class I, Div. 1, Groups B, C and D Hazardous (Classified) Locations per FM 3615. Operating temperature limits are  $-40^{\circ}\text{C}$  to  $+40^{\circ}\text{C}$ .

*NOTE: Sensor cross sensitivity has not been verified by FM.*

- Calibration of the above listed sensors has been FM verified using the respective EQ22xxDCU, EQ22xxDCUEX, UD10-DCU and PIRECL with the Det-Tronics 225130-001 (50% LFL methane) and/or 227115-001 H2S Calibration Kits.
- The UD10-DCU and EQ22xxDCU Series can be used with any FM Approved 4–20 mA device.

#### NOTE

*FM Approval of the 4–20 mA input does not include or imply approval of the gas detection apparatus such as sensors, transmitters, or devices connected to the system. In order to maintain FM Approval of the system, all 4–20 mA gas detection instruments connected to the input must also be FM Approved.*

#### NOTE

*FM Approval allows the presence and operation of serial/Ethernet communications software in the Controller (Modbus TCP/IP, Allen Bradley protocols, etc.); however, the communications functions are not included in the Approval.*

## **EAGLE QUANTUM PREMIER® FIRE AND GAS ALARM CONTROL PANELS:**

### **Hazardous Locations:**

#### **Non-Incendive Solutions (Class 1, Div 2):**

EQ3900N - See Manual 95-8559

#### **Explosion Proof Solution (Class 1, Div 1):**

EQ3900E - See Manual 95-8763

EQ3900RPSE Remote Power Supply Enclosure - See Manual 95-8745

EQ3770EIO - Remote I/O Module Enclosure - See Manual 95-8761

#### **Ordinary Locations:**

EQ3900G - See Manual 95-8641

EQ3900RPSG - See Manual 95-8745



Table A-1—Circuit Classifications

Signaling Path	NFPA 72® Supervision
Local Operating Network (LON)	Signaling Line Circuit (SLC): Class X
Power Distribution Module, Input Power	Supervised. Loss of power per ANSI/NFPA 72®, Cl. 10.6.9
Power Distribution Module, Controller Power Output	Supervised. Loss of power per ANSI/NFPA 72®, Cl. 10.6.9
Power Distribution Module, Field Device Power Output	Class B
Power Distribution Module, Local Field Device Power Output	Unsupervised per ANSI/NFPA 72®, Cl. 12.6.9
Power Supply Monitor, Input Power	Supervised. Loss of power per ANSI/NFPA 72®, Cl. 10.6.9
Power Supply Monitor, Output Power	Supervised (via Controller for opens). Class B
Power Supply Monitor, Charger	Supervised. Loss of charger per NFPA Cl. 10.6.10.6
Power Supply Monitor, Battery	Supervised. Loss of battery per NFPA Cl. 10.6.9
Controller, Digital Input	Unsupervised per ANSI/NFPA 72®, Cl. 12.6.9
Controller, Relay Output	Unsupervised per ANSI/NFPA 72®, Cl. 12.6.9
Controller, Trouble Relay Output	Unsupervised per ANSI/NFPA 72®, Cl. 12.6.9
Controller, 232 Expansion Output (SIL or Non-SIL)	Unsupervised per ANSI/NFPA 72®, Cl. 12.6.9
Controller, Ethernet Expansion Output (SIL or Non-SIL)	Unsupervised per ANSI/NFPA 72®, Cl. 12.6.9
Controller, SLC485 Expansion Output, including optional fiber optic equipment (SIL or Non-SIL)	Class B (Single Channel Single-Mode Fiber) Class X (Multi-Mode Fiber or Dual Channel Single-Mode Fiber or Dual Channel Wire)
Redundant Controller Connector, RS-232 (SIL or Non-SIL)	Unsupervised per ANSI/NFPA 72®, Cl. 12.6.9
Relay Module, Output	Unsupervised, for connection with ancillary equipment only.
Enhanced Discrete I/O, Input (software configurable, SIL or Non-SIL)	Unsupervised per ANSI/NFPA 72®, Cl. 12.6.9
	Initiating Device Circuit (IDC): Class A or Class B
Enhanced Discrete I/O, Output (software configurable, SIL or Non-SIL)	Unsupervised per ANSI/NFPA 72®, Cl. 12.6.9
	Notification Appliance Circuit (NAC): Class A or Class B
	Supervised Solenoids (Class A or Class B): Parker (Viking): 11591 NC, 11592 NC, 71395SN2#NJ1N0H111C2, 73218BN4TNLVN0C322C2, 73212BN4TNLVN0C322C2, and 73212BN4TN00N0C111C2 ASCO RedHat: R8210A107, 8210A107, 8210G207, HV274608 NC, HV2740607 NC Viking PN: 11601, 11602 Kidde-Fenwal: 897494, 895630, 890181 Cat #: 202-749-260563, 202-749-260563 Det-Tronics PN: 00219-209 Ansul: 570537 Macron: 304.209.001

Table A-1—Circuit Classifications-Continued

Signaling Path	NFPA 72® Supervision
Discrete I/O, Input (software configurable)	Unsupervised per ANSI/NFPA 72®, Cl. 12.6.9
	Initiating Device Circuit (IDC): Class B
Discrete I/O, Output (software configurable)	Unsupervised per ANSI/NFPA 72®, Cl. 12.6.9
	Notification Appliance Circuit (NAC): Class B
	Supervised Solenoids (Class B): Group B: ASCO T8210A107 Group D: ASCO 8210G207 Group E: Skinner 73218BN4UNLVNOC111C2 Group F: Skinner 73212BN4TNLVNOC322C2 Group G: Skinner 71395SN2ENJ1NOH111C2 Group H: Viking 11601
Analog Input Module (SIL or Non-SIL)	Initiating Device Circuit (IDC): Class B
IDCGF Input (Channel 2 only)	Unsupervised per ANSI/NFPA 72®, Cl. 12.6.9
ASM/ASH Loop (Smoke & Heat Loop)	Signaling Line Circuit (SLC): Class A or Class B (single spur)
ASM/ASH Loop (Smoke & Heat Loop) with Isolators	Signaling Line Circuit (SLC): Class X
ASM/ASH Loop (Smoke & Heat Loop) with Isolators	Signaling Line Circuit (SLC): Class B (single spur)
ASM/ASH - Addressable Smoke and Heat Module Input (software configurable)	Unsupervised per ANSI/NFPA 72®, Cl. 12.6.9
	Initiating Device Circuit (IDC): Class A
ASM/ASH - Addressable Smoke and Heat Module Input - Smoke detector inputs	Initiating Device Circuit (IDC): Class A (Apollo)
ASM/ASH - Addressable Smoke and Heat Module Output (software configurable)	Unsupervised per ANSI/NFPA 72®, Cl. 12.6.9
	Notification Appliance Circuit (Apollo): Class A
High Speed Deluge Module, Input (software configurable)	Unsupervised per ANSI/NFPA 72®, Cl. 12.6.9
	Initiating Device Circuit (IDC): Class A or Class B
High Speed Deluge Module, Output (software configurable)	Unsupervised per ANSI/NFPA 72®, Cl. 12.6.9
	Notification Appliance Circuit (NAC): Class A or Class B
	Supervised Solenoids (Class A or Class B): Parker (Viking): 11591 NC, 11592 NC, 71395SN2ENJ1NOH111C2, 73218BN4UNLVNOC111C2, 73212BN4TNLVNOC322C2, and 73212BN4TN00NOC111C2 ASCO RedHat: R8210A107, 8210A107, 8210G207, HV2740607 NC (Viking 11601), HV274608 NC (Viking 11602) Kidde-Fenwal: 897494 (Cat #: 202-749-260563), 895630 (Cat #: 81-895630-000), 890181 (Det-Tronics PN: 00219-209) Anslu: 570537 (Macron: 304.209.001) ASCO Redhat: EF8210G002
High Speed Deluge Module, Cascade (software configurable)	Initiating Device Circuit (IDC): Class B (via Cascade Input Channel)



# APPENDIX B

## CSA INTERNATIONAL CERTIFICATION DESCRIPTION

**CLASS – 4818 04** – Signal Appliances – System – For Hazardous Locations

**CLASS – 4828 01** – Signal Appliances – Combustible Gas Detection Instruments for Hazardous Locations

**CLASS – 4828 02** – Signal Appliances – Toxic Gas Detection Instruments for Hazardous Locations

### HAZARDOUS LOCATIONS

#### Eagle Quantum Premier® (EQP) System and Components

Class I Division 2 Groups A, B, C & D, T4

Class I Zone 2 IIC, T4, When installed in a suitable CSA Certified labeled Type rated enclosure:

EQ3xxx Controller Series, EQ3700DCIO Series, EQ3710AIM Series, EQ3730EDIO Series, HIM, EQ2220GFM, EQ2230RSP, EQ3750ASH Series, EQ3760ASM Series, EQ3LTM, EQ3780HSDM series.

Class I Division 2, Groups A, B, C & D, T3C

Class I Zone 2 IIC, T3, When installed in a suitable CSA Certified labeled Type rated enclosure:

EQ3720RM Series

Class I Division 1 Groups B, C & D, T4

Class I Division 2 Groups A, B, C & D, T4

Class II Division 1 Groups E, F & G, T4

Class II Division 2 Groups F & G, T4

Class III Division 1, T4

Class III Division 2, T4, TYPE 4X:

EQ22abDCU Series, EQ22abDCUEX Series, EQ22xxUVHT Series, EQ22xxIDC & EQ22abIDCGF Series, EQ24xxNE Series, EQ24abPLR Series, EQ25abARM Series, Q25abSAM Series

#### EQP System Power Supply(s) and Components

Class I Division 2 Groups A, B, C & D (UL & ULC), When installed in a suitable CSA Certified labeled Type rated enclosure:

EQP2120PS(-B), EQP2410PS(-P), Diode Redundancy Module

Class I Division 2 Groups A, B, C & D, T3A

Class I Zone 2 IIC, T3, When installed in a suitable CSA Certified labeled Type rated enclosure:

EQ3800PDM

Ordinary Location:

EQ21xxPS, EQ2100PSM

#### EQP System Enclosure Solutions

Class I Division 1 Groups C & D, T6

Class I Division 2 Groups A, B, C & D, T4

Class II Division 1 Groups E, F & G, T4, Class III Division 1 T4, TYPE 4X:

EQ3900RPS

Class I Division 1 Groups B, C & D, T5

Class I Zone 1 IIB, T5

Class II Division 1 Groups E, F & G, T5

Class III, T5, TYPE 4X:

EQ3900E Series

Class I Division 1 Groups B, C & D, T6, TYPE 4X:  
EQ3770EIO Series

Class I Division 2 Groups A, B, C & D T3A  
Class I Zone 2, IIC T3, TYPE 4X:  
EQ3900N Series

Ordinary Locations :  
EQ3900G Series

**EQP System Gas Detector / Sensors Class 4828-01 & 4828-02 (See individual Certificates)**  
PIRECL® Series, PIR9400 Series, PIRDUCT Series, OPECL Series, LS2000 Series, GT3000 Series, NTM Series, C7064E Series, CGS Series (Note: EQ22abDCUEX and UD10xxxxxC are required for use with CGS catalytic sensor.), PIRTB Series, STB Series, UD10 Series.

**EQP System Flame Detectors Equipment Class 4818 04 (See individual Certificates)**  
X3301 Series, X3302 Series, X2200 Series, X9800 Series, X5200 Series

**Notes:**

**Note 1:** Any CSA certified Combustible or Toxic Gas Sensor / detector with 4-20mA (industry standard) output may be used with EQ3710AIM, UD10 and EQ22abDCU.

**Note 2:** Detector Electronics combustible gas detection K factors are not CSA verified.

**Note 3:** CSA Certification of the 4-20mA input does not include or imply approval of the gas detection apparatus such as sensors, transmitters, or devices connected to the system. In order to maintain CSA Certification of the system, all 4-20mA gas detection instruments connected to the input must also be CSA Certified.

**Note 4:** CSA Certification allows the presence and operation of serial/Ethernet communications software in the Controller (Modbus TCP/IP, Allen Bradley protocols, etc.); however, the communications functions are not included in the Certification.



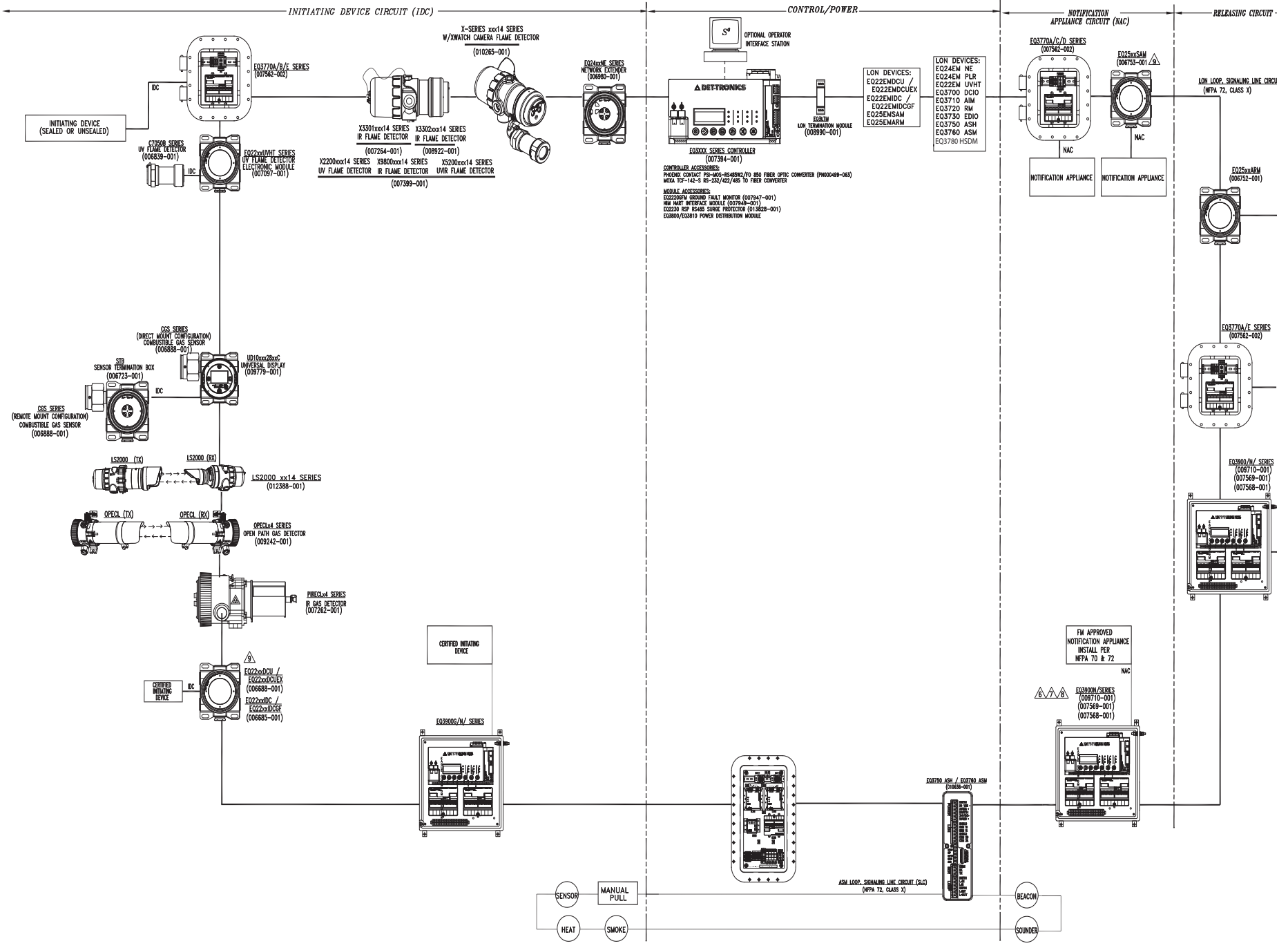

Figure B-2 UL Drawing

## **APPENDIX C**

### **ATEX AND IECEX CERTIFICATION**

#### **ATEX AND IECEX CERTIFICATION DETAILS**

The Eagle Quantum Premier® Fire and Gas Detection / Releasing System was tested and certified to hazardous location and combustible gas performance standards.

The ATEX/IECEX certified Eagle Quantum Premier® System field devices EQ22..., EQ24... and EQ25... are in compliance with the following standards, as applicable:

- IEC 60079-0: 6th Edition
- IEC 60079-1: 7th Edition
- EN 60079-0: 2012 + A11:2013
- EN 60079-1: 2014
- EN 60079-29-1: 2007
- EN 60079-29-4: 2010

The ATEX/IECEX certified Ex n modules of the EQP system are in compliance with the following standards, as applicable:

- IEC 60079-0: 6th Edition
- EN 60079-0: 2012 + A11:2013
- IEC 60079-15: 4th Edition
- EN 60079-15: 2010
- EN 60079-29-1: 2007
- EN 60079-29-4: 2010

#### **SPECIAL CONDITIONS FOR SAFE USE**

1. The equipment shall only be used in an area of not more than pollution degree 2, as defined in IEC/EN 60664-1.
2. The equipment shall be installed in an enclosure that provides a degree of protection not less than IP 54 in accordance with IEC/EN 60079-15. The equipment shall only be accessible with use of a tool. This provision applies only to Ex n devices.
3. Transient protection shall be provided that is set at a level not exceeding 140% of the peak rated voltage value at the supply terminals to the equipment.
4. The flameproof joints are not intended to be repaired.

#### **FOR ALL ATEX/IECEX CERTIFIED EX N MODULES IN THE EQP SYSTEM, THE FOLLOWING SPECIAL CONDITIONS FOR SAFE USE APPLY:**

The ambient temperature range is limited for EQ3XXX:

- From -40°C to +70°C if any of the output relays 1-7 (terminals 21-41) is used (energized).
- From -40°C to +80°C if all output relays 1-7 (terminals 21-41) remain open-contacted and de-energized.

For compliance to EN 60079-29-1/-4, the relevant Ex n module must be used with gas detection apparatus that are certified for compliance to EN60079-29-1/-4 and that provide a suitable linear 4-20 mA output, relay contact output or LON communication output relative to the %LFL of the available gas in the area of the gas detection apparatus. See the Manual for details on the required connection parameters.

The EQP Ex n modules shall be used in an area of no more than pollution degree 2 conforming to IEC/EN 60664-1, and in an enclosure with a tool removable cover that complies with all relevant requirements of IEC/EN 60079-15, rated at least IP54, and shall be connected to supply circuits where the rated voltage cannot be exceeded by 140% caused by transient disturbances.



## PERFORMANCE TESTING TO EN 60079-29-1: 2007 AND EN 60079-29-4: 2010

The measuring function of the EQ3XXX Controller, according to Annex II paragraph 1.5.5, 1.5.6 and 1.5.7 of the Directive 94/9/EC, was covered in this Type Examination Certificate in the following configurations:

1. Controller Model EQ3XXX with EQ3710AIM or EQ3700DCIO or EQ3730EDIO or EQ22XXDCU (tested as a stand-alone control unit with a calibrated linear 4-20mA simulator input signal or relay contacts (as applicable).
2. Controller Model EQ3XXX with CTB and PIRECL (tested as a gas detection system with methane applied to the PIRECL).
3. Controller Model EQ3XXX with UD10/DCU Emulator and CGS Conditioning Board, in combination with the Det-Tronics gas sensor Model CGS (tested as a gas detection system with methane applied to the CGS).
4. Controller Model EQ3XXX with OPECL or LS2000.

### **FOR THE ATEX CERTIFIED EAGLE QUANTUM PREMIER® SYSTEM FIELD DEVICES EQ22XXDCU AND EQ22XXDCUEX, THE FOLLOWING SPECIAL CONDITION FOR SAFE USE APPLIES:**

The field devices EQ24XXNE, EQ22XXDCU and EQ22XXDCUEX have an ambient temperature rating for performance of -40°C to +75°C.

#### **IMPORTANT NOTE**

*All applied gas detectors must be ATEX certified to EN60079-29-1/-4 and the configuration must comply with the gas performance parameters stated in the Installation Manual.*

**APPENDIX D**  
**EAGLE QUANTUM PREMIER® SYSTEM**  
**MARINE APPLICATIONS DNV AND**  
**U.S. COAST GUARD APPROVAL NUMBER 161.002/49/0**

**Approved System Description**

Refer to Table D-1 for a complete list of DNV and USCG approved equipment.

Table D-1— List of Approved Equipment

Equip. No.	Manufacturer	Equipment type	Series/Model Description
1	Det-Tronics	EQ3XXX Controller	EQ3XXXP N(C) N(S) W(T)-C, panel mount only; installed inside Rittal cabinet or equivalent NEMA 12 enclosure in controlled environments; NEMA 4X enclosure for open area installations.
2	Det-Tronics	EQ3LTM LON Termination Module	Optional module used in the Controller Redundancy configuration, installed inside Rittal cabinet or equivalent NEMA 12 enclosure in controlled environments; NEMA 4X enclosure for open area installations.
3	Det-Tronics	EQ3710AIM Analog Input Module	EQ3710D(P) W, installed inside Rittal cabinet or equivalent NEMA 12 enclosure in controlled environments; NEMA 4X enclosure for open area installations.
4	Det-Tronics	EQ3720RM Relay Module	EQ3720D(P) W, installed inside Rittal cabinet or equivalent NEMA 12 enclosure in controlled environments; NEMA 4X enclosure for open area installations.
5	Det-Tronics	EQ3730EDIO Enhanced Discrete Input/Output Module	EQ3730D(P) W(T); installed inside Rittal cabinet or equivalent NEMA 12 enclosure in controlled environments; NEMA 4X enclosure for open area installations.
6	Det-Tronics	EQ3750ASH Addressable Smoke & Heat Module	EQ3750ASHP W; panel mount only, installed inside Rittal cabinet or equivalent NEMA 12 enclosure in controlled environments; NEMA 4X enclosure for open area installations.
7	Det-Tronics	EQ24xxNE Network Extender Module	EQ245(6) 3NE; Enclosure material: 5 – Aluminum, 6 –SS.
8	Det-Tronics	EQ22xxDCUEX Digital Communication Unit, Combustible	EQ225(6)3DCUEX; Enclosure material: 5 – Aluminum, 6 –SS. (Uses CGS Gas Sensor)
9	Det-Tronics	CGS Combustible Gas Sensor	CGSS1A6C2R1X (Used with the EQ22xxDCUEX)
10	Det-Tronics	PIRECLAx4 PointWatch Hydrocarbon Gas Detector	PIRECLA (1) 4 A (B) 1 (2) W (T) 1 (2)
11	Det-Tronics	PIRECLAx4 PointWatch Hydrocarbon Gas Detector "Duct Mount"	PIRECLA (1) 4 A (B) 1 (2) W (T) 1 (2); with DEC Q900C1001 Duct Mount kit

Table D-1— List of Approved Equipment (Continued)

Equip. No.	Manufacturer	Equipment type	Series/Model Description
12	Det-Tronics	GT3000 Toxic Gas Detector	Model GTXS N (M) W 4 (5) Transmitter with Model GTSH2S 20P (50P,100P) Sensor or Model GTSO2 25V Sensor or Model GTSCO 100P (500P) Sensor
13	Det-Tronics	UD10 Universal Display	UD10A (S) 5N (5M) 25 (28) W 2
14	Det-Tronics	X3301 Multispectrum Flame Detector	X3301A (S) 4N (4M) 11 (13, 14, 23) W (T) 1 (2) ; with Q9033A AI (Q9033B SS) swivel
15	Det-Tronics	X3302 Multispectrum Flame Detector	X3302A (S) 4N (4M) 11 (13, 14, 23) W 1 (2); with Q9033A AI (Q9033B SS) swivel
16	Det-Tronics	STB Sensor Termination Box	STB4 (5) A (S) 2N (2U, 3N, 5N, 6N) W (Used with the Fenwal DAF Vertical Heat Detector)
17	Det-Tronics	EQ2220GFM Ground Fault Monitor	EQ2220GFM is installed in the same enclosure with EQ3XXX Controller
18	Phoenix Contact (Germany)	EQP2120PS-B Power Supply (Discontinued)	Model Quint PS-100-240VAC/24Vdc/20; panel mount only, installed in the same enclosure with EQ3XXX Controller
19	Phoenix Contact (Germany)	EQP2120PS-B Power Supply (Replacement)	Model QUINT PS-1AC/24 DC/20 panel mount only, installed in the same enclosure with EQ3XXX Controller
20	Phoenix Contact (Germany)	EQP2410PS-P Converter	Model QUINT PS-24 DC/24 DC/10 panel mount only, installed in the same enclosure with EQ3XXX Controller
21	Phoenix Contact (Germany)	QUINT- DIODE/40Diode Redundancy Module	Model QUINT-DIODE/40; panel mount only; installed in the same enclosure with EQ3XXX Controller and Approved Phoenix Power Supplies
22	Kidde-Fenwal (Fenwal)	DAF Vertical Heat Detector	Model 12-E27121-020-xx rated 140°F (60°C) {160°F (71°C), 190°F (88°C), 225°F (107°C)}; used with STB Sensor Termination Box, item 15
23	Fenwal	THD-7052 Heat Detector	Uses 2-wire base 2WRLT.
24	Fenwal	CPD-7054 Ionization Type Smoke Detector	Uses 2-wire base 2WRLT.
25	Fenwal	PSD-7157 and PSD-7157D Photoelectric Type Smoke Detectors	Uses 2-wire base 2WRLT.
26	Fenwal	MT-12/24-R Horn	24 Vdc model; installed in Fenwal IOB-R box.
27	Fenwal	MTWP-2475W – FR Horn/Strobe	Multitone Weatherproof Horn-Strobe; installed in Fenwal IOB-R box.
28	Fenwal	Manual Call Stations Series 3300	Model 84-330001-002 pull station; uses Fenwal SGB-32S interior surface mount backbox (compatible mounting with B-11).

Table D-1— List of Approved Equipment (Continued)

Equip. No.	Manufacturer	Equipment type	Series/Model Description
29	Fenwal	RA-911 Remote Indicator	Remote indicator for use with Fenwal Heat or Smoke detectors.
30	MEDC (UK)	Manual Fire Alarm Call Point PB Range	Model PB-UL-4C-6C-4-DC-D-7-R call point
31*	Cooper Crouse Hinds	CCH ETH 2416 Horn	Uses CCH EAJC26 conduit outlet box with cover, 3/4 NPT hub size.
32	Applied Strobe Technology (Canada)	AST-4-1030 Strobe	AST-4-10-30-DC-CL-CM-75-ULC; with clear lenses
33	Air Products & Controls	SL-2000-P Duct Smoke Detector	SL-2000-P; installed in Hoffman LWC204015SS6 NEMA 4X enclosure; uses Apollo 55000-328A photoelectric head w/ RW-268A base.
34	Apollo Fire Detectors Ltd.	Discovery Ionization Smoke Detector	Apollo P/N 58000-550NA (with 4" Base Model P/N 45681-210)
35	Apollo Fire Detectors Ltd.	Discovery Optical Smoke Detector	Apollo P/N 58000-650NA (with 4" Base Model P/N 45681-210)
36	Apollo Fire Detectors Ltd.	Discovery Multisensor Detector	Apollo P/N 58000-750NA (with 4" Base Model P/N 45681-210)
37	Apollo Fire Detectors Ltd.	Discovery Heat Detector	Apollo P/N 58000-450NA (with 4" Base Model P/N 45681-210)
38	Apollo Fire Detectors Ltd.	XP95A Sounder Control Module	Apollo P/N 55000-825NA
39	Apollo Fire Detectors Ltd.	Mini Switch Monitor	Apollo P/N 55000-765NA**
40	Apollo Fire Detectors Ltd.	Priority Mini Switch Monitor	Apollo P/N 55000-765NA**

\* Horn item 32 is for use in gas applications only.

\*\* The device type depends on the priority switch setting on the device.

NA = North American Approvals

## IMPORTANT

The EQP2120PS-B Power Supply provides EQP System devices with power from input supply 120 to 220 Vac. The EQP2120PS-B Power Supply is used in pairs where primary source of input supply is connected to one and the secondary source is connected to the other. Use of these power supplies may provide the source of the secondary supply. The EQP2410PS-P Converter provides the EQP system with power from input supply 24 Vdc and provides the source if secondary supply only.

### NOTE

*The customer may provide other sources of the secondary supply such as secondary source batteries, their supervision or charging, or UPS. Per NFPA 72®-2013 requirements, such power supply related requirements must be separately provided for and be accepted by the local Authority Having Jurisdiction (AHJ).*

## SYSTEM SPECIFICATION

### EQP2120PS-B POWER SUPPLY (DISCONTINUED)—

<b>Number of units:</b>	16 (8 pairs) max
<b>Input voltage:</b>	120 – 220 Vac, -15%, +10%, 60/50 Hz single phase
<b>Output voltage:</b>	Nominal— 24.5 Vdc ± 1% Vdc Range— 24.5....28.0 Vdc
<b>Input current:</b>	Vout = 24.5 Vdc: 4.9 Amps @ 120 Vac 2.9 Amps @ 220 Vac. Vout = 28.0 Vdc: 5.6 Amps @ 120 Vac 3.2 Amps @ 220 Vac.
<b>Output current, each:</b>	20 A

### EQP2120PS-B POWER SUPPLY (REPLACEMENT)—

<b>Number of units:</b>	16 (8 pairs) max
<b>Input voltage:</b>	120 – 220 Vac, -15%, +10%, 60/50 Hz single phase
<b>Output voltage:</b>	Nominal— 24.5 Vdc ± 1% Vdc Range— 24.5....28.0 Vdc
<b>Input current:</b>	6.6 A max @120 Vac 3.6 A max @220 Vac.
<b>Output current, each:</b>	20 A

### EQP2410PS-P CONVERTER—

<b>Number of units:</b>	16 (8 pairs) max
<b>Input voltage:</b>	24 Vdc, -15%, +10%
<b>Output voltage:</b>	Nominal— 24.5 Vdc ± 1% Vdc Range— 24.5....28.0 Vdc
<b>Input current:</b>	15.7 A max @ 24 Vdc.
<b>Output current, each:</b>	10 A

### QUINT-DIODE/40 REDUNDANCY MODULE

<b>Number of units:</b>	8 (2 Power Supplies can be connected to each module) max
<b>Input voltage:</b>	24.5....28.0 Vdc

## IMPORTANT

*The output voltage is adjustable. An even current distribution must be ensured by precisely setting all power supply units that are operated in parallel to the same output voltage ±10 mV.*

## IMPORTANT

*To ensure symmetrical current distribution it is recommended that all cable connections from all power supply units/diode redundancy modules to the power distribution bus are the same length and have the same cross section.*

### POWER REQUIREMENT—

Refer to Section 6 of this manual and individual device manuals for details.

#### NOTE

*The Power Supplies, Converter, and Diode Redundancy Module electrical specifications for EQP marine applications represent a reduction in the rating range with respect to that specified by the manufacturer. The manufacturer's published electrical specifications may be viewed as reference only.*

### TEMPERATURE AND HUMIDITY RANGE—

See Table D-2 for details.

#### NOTE

*The operating temperature and relative humidity specification of EQP System components including Power Supplies, Converter, and Diode Redundancy Module in EQP marine applications represent a reduction in the rating range for some components and an increase in the rating range for other components with respect to that specified by their manufacturers. The manufacturer's published operating temperature and relative humidity specifications may be viewed as reference only.*

### INSTALLATION—

The EQP2120PS-B Power Supply, EQP2410PS-P Converter, and Diode Redundancy Module are Panel mounted and intended to be installed within the same cabinet as the EQ3XXX Controller of the EQP System. **Note: Ensure sufficient convection.** Refer to Phoenix Contact manuals as listed below for additional installation and mounting details. For other EQP System components installation, operation and maintenance refer to appropriate sections of this manual and to individual device manuals.

**NOTE**

*SHCS # 10-24 SST screws are recommended for the Power Supply and Diode Redundancy Module panel mounting.*

**NOTE**

*Terminal End Brackets DEC P/N 000133-517 are recommended for use with EQ371(2)(3)0D (DIN rail mount) and EQ2220GFM Modules.*

**POWER SUPPLY SUPERVISION—**

The EQP2120PS-B Power Supply and EQP2410PS-P Converter shall be monitored for Trouble. The power supply provides an internal relay contact DC OK signal output, floating. All power supply unit relay contacts shall be connected in series and connected to the EQ3730EDIO input. A Trouble signal will be initiated in case of a power supply failure. The Trouble signal will not identify the specific power supply unit that failed. See Figure D-2 for connecting diagram.

**EQP SYSTEM MODEL 000523-009 & 000523-010**

- The System consists of:
  - 1 x EQP2120PS-B Power Supply, primary
  - 2 x EQP2410PS-P Converter, secondary
  - 2 x QUINT-DIODE/40 Redundancy module
  - 1 x EQ2220GFM Ground Fault Monitor
  - 1 x EQ3XXX Controller (000523-009)
  - 0 x EQ3XXX Controller (000523-010)
  - 0 x EQ3710AIM Module & 1 x EQ3730EDIO Module (000523-009)
  - 2 x EQ3710AIM Modules & 2 x EQ3730EDIO Modules (000523-010)
- The System is mounted within 60H x 36W x 16D Stainless Steel (type 316), NRTL labeled NEMA 4X rated enclosure. The enclosure shall be lockable by key lock or padlock.
- EQP system models 000523-009 & 000523-010 are suitable for CI I, Div. 2, GRPS A, B, C & D (T4); CI I, Zone 2, GRP IIC (T4) Hazardous (Classified) Locations; Tamb = -20°C to +49°C.
- Modifications to enclosure (such as conduit entry holes, windows etc.) are permitted when implemented by the manufacturer of the enclosure.

## ORDERING INFORMATION

DEVICES MARKED WITH USCG INSIGNIA	
Model	Description
EQP2120PS-B (Discontinued)	Phoenix Contact QUINT-PS-100-240AC/24DC/20 Panel Mount
EQP2120PS-B (Replacement)	Phoenix Contact QUINT-PS-1AC/24DC/20 Panel Mount
EQP2410PS-P	Phoenix Contact QUINT-PS-24DC/24DC/10 Panel Mount
Diode Redundancy Module	Phoenix Contact QUINT-DIODE/40 Panel Mount
EQ3XXX N(C) N(S) W(T)-C	EQP System Controller, panel mount
Q900C1001	Duct Mount Kit
000523-009	See description on page D-6
000523-010	See description on page D-6

For other USCG Approved EQP System components, refer to Table D-1 or contact Det-Tronics Customer Service.

Refer to Section 3 of this manual for determining power requirements.

USCG insignia marked on the controller and power supplies indicates USCG certification of a system made-up of components in Table D-1.



Table D-2—Temperature and Humidity Ranges

Equip. No.	Product	Temperature & RH Non-Condensing		
		Installation Category		
		Controlled environment	Installation in consoles, housings, etc.; Non-weather protected or cold locations	Weather exposed areas (Salt mist)
1*	EQ3XXX Controller with or without EQ3LTM Module	0°C to +55°C 5-95%RH	-25°C to +70°C 5-95%RH	-25°C to +70°C 5-95%RH
2*	EQ3710AIM Analog Input Module	0°C to +55°C 5-95%RH	-25°C to +70°C 5-95%RH	-25°C to +70°C 5-95%RH
3*	EQ3720RM Relay Module	0°C to +55°C 5-95%RH	-25°C to +70°C 5-95%RH	-25°C to +70°C 5-95%RH
4*	EQ3730EDIO Enhanced Discrete Input/Output Module	0°C to +55°C 5-95%RH	-25°C to +70°C 5-95%RH	-25°C to +70°C 5-95%RH
5	EQ3750ASH	0°C to +55°C 5-95%RH	-25°C to +70°C 5-95%RH	-25°C to +70°C 5-95%RH
	EQ3760ASM	0°C to +55°C 5-95%RH	-25°C to +70°C 5-95%RH	-25°C to +70°C 5-95%RH
6	EQ24xxNE Network Extender Module	0°C to +55°C 5-95%RH	-25°C to +70°C 5-95%RH	-25°C to +70°C 5-95%RH
7	EQ22xxDCUEX Digital Communication Unit, Combustible	0°C to +55°C 5-95%RH	-25°C to +70°C 5-95%RH	-25°C to +70°C 5-95%RH
8	CGS Combustible Gas Sensor	0°C to +55°C 5-95%RH	-25°C to +70°C 5-95%RH	-25°C to +70°C 5-95%RH
9	PIRECLx4 PointWatch Hydrocarbon Gas Detector	0°C to +55°C 5-95%RH	-25°C to +70°C 5-95%RH	-25°C to +70°C 5-95%RH
10	PIRECLx4 PointWatch Hydrocarbon Gas Detector "Duct Mount"	0°C to +55°C 5-95%RH	-25°C to +70°C 5-95%RH	-25°C to +70°C 5-95%RH
11	GT3000 Toxic Gas Detector	0°C to +50°C 5-95%RH	-20°C to +50°C 5-95%RH	-20°C to +50°C 5-95%RH
12	UD10 Universal Display	0°C to +55°C 5-95%RH	-25°C to +70°C 5-95%RH	-25°C to +70°C 5-95%RH
13	X3301 Multispectrum Flame Detector	0°C to +55°C 5-95%RH	-25°C to +70°C 5-95%RH	-25°C to +70°C 5-95%RH
14	X3302 Multispectrum Flame Detector	0°C to +55°C 5-95%RH	-25°C to +70°C 5-95%RH	-25°C to +70°C 5-95%RH

Table D-2—Temperature and Humidity Ranges (Continued)

Equip. No.	Product	Temperature & RH Non-Condensing		
		Installation Category		
		Controlled environment	Installation in consoles, housings, etc.; Non-weather protected or cold locations	Weather exposed areas (Salt mist)
15	STB Sensor Termination Box	0°C to +55°C 5-95%RH	-25°C to +70°C 5-95%RH	-25°C to +70°C 5-95%RH
16*	EQ2220GFM Ground Fault Monitor	0°C to +55°C 5-95%RH	-25°C to +70°C 5-95%RH	-25°C to +70°C 5-95%RH
17	EQP2120PS-B Power supply	0°C to +55°C 5-95%RH	-25°C to +55°C 5-95%RH	-25°C to +55°C 5-95%RH
18*	EQP2410PS-P Converter	0°C to +55°C 5-95%RH	-25°C to +55°C 5-95%RH	-25°C to +55°C 5-95%RH
19*	QUINT-DIODE/40Diode redundancy module	0°C to +55°C 5-95%RH	-25°C to +70°C 5-95%RH	-25°C to +55°C 5-95%RH
20	DAF Vertical Heat Detector	0°C to +55°C 5-95%RH	-25°C to +70°C 5-95%RH	-25°C to +70°C 5-95%RH
21	THD-7052 Heat Detector	0°C to +55°C 5-95%RH	N/A	N/A
22	CPD-7054 Ionization Type Smoke Detector	0°C to +55°C 5-95%RH	N/A	N/A
23	PSD-7157 and PSD-7157D Photoelectric Type Smoke Detectors	0°C to +55°C 5-95%RH	N/A	N/A
24	MT-12/24-R Horn	0°C to +55°C 5-95%RH	-25°C to +70°C 5-95%RH	N/A
25	MTWP-2475W – FR Horn/Strobe	0°C to +55°C 5-95%RH	-25°C to +55°C 5-95%RH	N/A
26	Manual Call Stations Series 3300	0°C to +55°C 5-95%RH	-25°C to +70°C 5-95%RH	N/A
27	RA-911 Remote Indicator	0°C to +55°C 5-95%RH	-25°C to +70°C 5-95%RH	N/A
28	Manual Fire Alarm Call Point PB Range	0°C to +55°C 5-95%RH	-25°C to +70°C 5-95%RH	-25°C to +70°C 5-95%RH
29	CCH ETH 2416 Horn	0°C to +55°C 5-95%RH	-25°C to +70°C 5-95%RH	-25°C to +70°C 5-95%RH

Table D-2—Temperature and Humidity Ranges (Continued)

Equip. No.	Product	Temperature & RH Non-Condensing		
		Installation Category		
		Controlled environment	Installation in consoles, housings, etc.; Non-weather protected or cold locations	Weather exposed areas (Salt mist)
30	AST-4-1030 Strobe	0°C to +55°C 5-95%RH	-25°C to +70°C 5-95%RH	-25°C to +70°C 5-95%RH
31	SL-2000-P Duct Smoke Detector	0°C to +55°C 5-95%RH	0°C to +70°C 5-95%RH	0°C to +70°C 5-95%RH
32	Discovery Ionization Smoke Detector	5°C to +55°C 5-95%RH	N/A	N/A
33	Discovery Optical Smoke Detector	5°C to +55°C 5-95%RH	N/A	N/A
34	Discovery Multisensor Detector	5°C to +55°C 5-95%RH	N/A	N/A
35	Discovery Heat Detector	5°C to +55°C 5-95%RH	N/A	N/A
36	XP95A Sounder Control Module	5°C to +55°C 5-95%RH	N/A	N/A
37	Mini Switch Monitor	5°C to +55°C 5-95%RH	N/A	N/A
38	Priority Mini Switch Monitor	5°C to +55°C 5-95%RH	N/A	N/A

\* For use in controlled environment, install in NEMA 12 rated enclosure or cabinet.

For use in non-weather protected, cold and salt mist exposed areas, install in NEMA 4X stainless steel enclosure or cabinet.

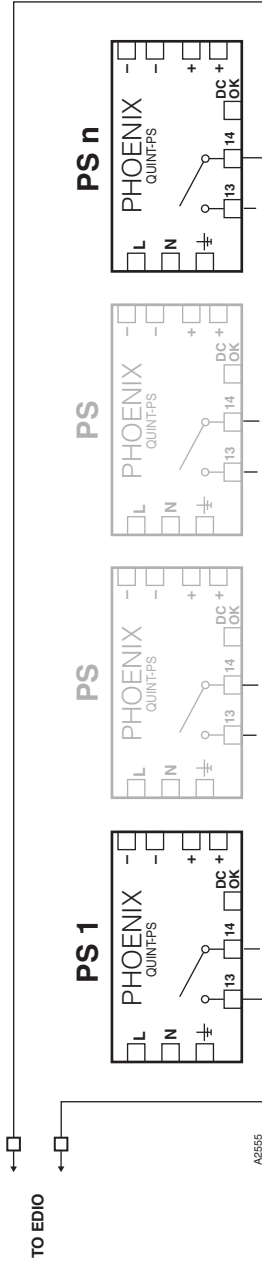

**Note:** Contacts are closed during normal operation. The circuit shall be wired to an input on the EQP system (EDIO). In Logic, the selected input must be inverted and used to activate an alarm trigger gate, which initiates a fault message on the Controller and activates the fault relay output.

**No supervision is necessary, since the EDIO modules must be installed in the same cabinet with EQP21X0PS and EQP2410PS.**

Figure D-1—Power Supply and Converter Relays Wired in Series for Trouble Monitoring (up to 16 Power Supplies/Converters)

# **APPENDIX E**

## **CE MARK**

### **EMC DIRECTIVE 2004/108/EC DETAILS**

The Eagle Quantum Premier® Fire and Gas Detection/Releasing System was tested and found to be compliant with EN61000-6-2, EN61000-6-4, EN50130-4, and EN50270. The following considerations must be given for installation of the Eagle Quantum Premier® system.

- For shielded cable installed in conduit, attach the wire shields to the “shield” connections on the terminal blocks, or to the earth ground on the case.
- For installations without conduit, use double shielded cable. Terminate the outer shield to the earth ground on the case. Terminate the inner shield to the “shield” connection on the terminal blocks.

### **ADDITIONAL DIRECTIVES**

- ATEX Directive: 94/9/EC  
Refer to Appendix C for details.
- Low Voltage Directive: 2006/95/EC
- WEEE Directive: 2002/96/EC



95-8533



FlexSonic® Acoustic  
Leak Detector



X3301 Multispectrum  
IR Flame Detector



PointWatch Eclipse® IR  
Combustible Gas Detector



FlexVu® Universal Display  
with GT3000 Toxic Gas Detector



Eagle Quantum Premier®  
Safety System

Specifications subject to change without notice.

All trademarks are the property of their respective owners.

© 2020 Detector Electronics Corporation. All rights reserved.



**Corporate Office**  
6901 West 110<sup>th</sup> Street  
Minneapolis, MN 55438 USA  
[www.det-tronics.com](http://www.det-tronics.com)

Phone: +1 952.941.6665  
Toll-free: +1 800.765.3473  
Fax: 952.829.8750  
[det-tronics@carrier.com](mailto:det-tronics@carrier.com)