

# DS Series Addressable Detector Application Guide

K-76-1000

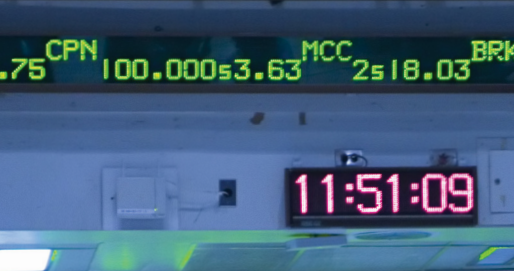

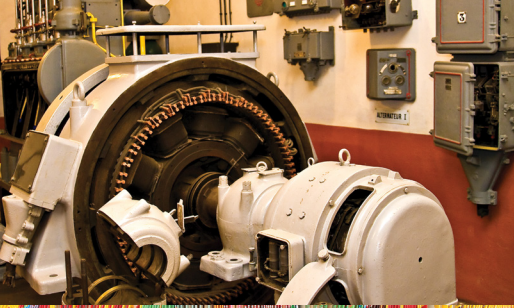

---

# FOREWORD

---

## PURPOSE OF THIS GUIDE

This guide, K-76-1000, is to be used by qualified and factory-trained personnel, knowledgeable of NFPA standards and any other applicable standards in effect. This guide is intended to provide guidance to qualified technical professionals for the installation and maintenance of the DS Series Addressable Detectors.

Any questions concerning the information presented in this guide should be addressed to:

Kidde-Fenwal, Inc.  
400 Main Street  
Ashland, MA 01721, USA  
Phone: (508) 881-2000  
Toll Free: (800) 872-6527  
Technical Support: (866) 287-2531  
Fax: (508) 881-8920  
[www.kiddefiresystems.com](http://www.kiddefiresystems.com)

## LIMITATION OF LIABILITY

Only qualified persons experienced and trained in the installation of this type of equipment should install and configure DS Series Addressable Detectors. Installation in accordance with this guide, applicable codes, and the instructions of the Authority Having Jurisdiction is mandatory.

The technical data contained herein is provided for informational purposes only, and should not be used as a substitute for professional judgment. The content of this manual is proprietary in nature and is intended solely for distribution to authorized persons, companies, distributors or others for the sole purpose of conducting business associated with Kidde-Fenwal, Inc. Although, Kidde-Fenwal, Inc. believes this information to be true and correct, it is published and presented without any guarantee or warranty whatsoever. Kidde-Fenwal, Inc. disclaims any liability for any use of the data other than as set out in this manual, foreword included.

The DS Series Addressable Detectors have been designed to meet the requirements of the following standards:

- CAN/ULC-S529-09
- ICES-003
- NFPA 72
- NFPA 720
- UL 268
- UL 268A•
- UL 521
- UL 864

## FCC WARNING

This equipment can generate and radiate radio frequency energy. If this equipment is not installed in accordance with this guide, it may cause interference to radio communications. This equipment was tested and found to comply within the limits for Class A computing devices pursuant to Subpart B of Part 15 of the FCC Rules. These rules provide reasonable protection against such interference when this equipment is operated in a commercial environment. If the operation of this equipment causes interference, the user must correct the interference and incur the expense.

---

## RELATED DOCUMENTATION

National Fire Protection Association (NFPA)  
1 Batterymarch Park  
Quincy, MA 02169-7471

- NFPA 70                      National Electric Code
- NFPA 72                      National Fire Alarm and Signaling Code

Underwriters Laboratories, Inc. (UL)  
333 Pfingsten Road  
Northbrook, IL 60062-2096

- UL 268                      Smoke Detectors for Fire Protective Signaling Systems
- UL 268A                      Smoke Detectors for Duct Applications
- UL 521                      Heat Detectors for Fire Protective Signaling Systems
- UL 864                      Control Units and Accessories for Fire Alarm Systems

Underwriters Laboratories of Canada (ULC)  
7 Underwriters Rd  
Toronto Canada M1R 3A9

- CAN/ULC S-529-09      Smoke Detectors for Fire Alarm Systems
- CAN/ULC-S530-M91      Heat Actuated Fire Detectors for Fire Alarm Systems

---

NOTES:

---

# OVERVIEW

---

## OVERVIEW OF DS SERIES ADDRESSABLE SMOKE AND HEAT DETECTORS

DS Series smoke and heat detectors are intelligent analog addressable devices which make alarm decisions based on the information collected by their sensors. The detectors are constructed of a high-impact polymer. Each detector features an optional base-locking tab. The following detectors and bases are available:

1. Model DS-PS Photoelectric Smoke Detector
  - addressable and intelligent
  - built-in two-color LED
  - conformal coated PCB
2. Model DS-HFS Programmable Fixed Temperature Heat Detector
  - addressable and intelligent
  - built-in two-color LED
  - conformal coated PCB
3. Model DS-SB Detector Base
  - 4-in. diameter
  - for 2-wire or 4-wire terminal connection to Signaling Line Circuit (SLC)
  - 6-in. trim ring included
4. Model DS-RB Detector Base
  - 4-in. diameter
  - for 2-wire or 4-wire terminal connection to Signaling Line Circuit (SLC)
  - terminal connections available for Normally Open and Normally Closed Relays
  - 6-in. trim ring included

## ORDERING INFORMATION

Part Number	Description
DS-PS	Intelligent Photoelectric Smoke Detector, head only
DS-HFS	Intelligent 135°F (57°C) Fixed-Temperature Heat Detector, head only
DS-SB	Detector Mounting Base, 4 in. diameter, with 6 in. trim ring and 2-wire or 4-wire terminal connection to SLC
DS-RB	Detector Mounting Base, 4 in. diameter, with 6 in. trim ring and 2-wire or 4-wire terminal connection to SLC and relay option
SIGA-DMP	Duct Mounting Plate for DS-PS Photoelectric Smoke Detector
2-SPRC1	Replacement Smoke Chamber for DS-PS Photoelectric Smoke Detector
SM200-12PKG	Canned smoke for functional testing of smoke detectors



---

## FEATURES

- **Addressing:** DS Series detectors feature electronic addressing. No addressing switches are used.
- **LEDs:** DS Series detectors use an LED to indicate the detector's condition. In normal condition, a flashing green LED indicates that the control panel is performing background supervision and a flashing red LED indicates an alarm condition.
- **Sensitivity:** The alarm sensitivity is the minimum obscuration level at which the detector initiates an alarm condition and can be specified via the control unit menus or the remote configuration software. The control unit to which these detectors are connected is capable of interrogating each detector to determine its sensitivity. The table below lists the acceptable smoke and heat ranges of sensitivity for the DS-PS and DS-HFS detectors:

Table 1. Acceptable Sensitivity Ranges for DS Series Detectors as Reported by Control Unit

Model	Detection elements	Factory-assigned sensitivity	Adjustable alarm point setting (%obsc./ft.)
DS-PS	Photoelectric (open air)	2.0% obsc./ft.	0.9 to 3.5% obsc./ft.
DS-PS	Photoelectric (in-duct)	2.0% obsc./ft.	0.9 to 2.0% obsc./ft.
DS-HFS	Fixed-temperature	135°F (57°C)	fixed 135°F (57°C)

- **Protocol:** DS Series detectors operate on a Kidde Fire Systems fire alarm-suppression control unit (Kidde, Fenwal and Chemetron brands) employing SmartOne® communications protocol and can be mixed in any order with SmartOne legacy detectors.

## SPACING AND LOCATION

This section discusses the parameters for the spacing and location of DS Series smoke and heat detectors. To better understand the requirements, use the following definitions:

**Beams** — are solid structures that project down from the ceiling surface more than 4 in. (100 mm) and are spaced at intervals of more than 36 in. (910 mm), center-to-center.

**Ceiling** — is the upper surface of a space, regardless of the height. Consider a ceiling:

- Smooth, if it is uninterrupted by continuous projections, such as solid joists, beams, or ducts that extend more than 4 in. (100 mm) below the ceiling surface.
- Level, if it has a slope of less than or equal to 1 in 8.
- Sloping, if it has a slope of more than 1 in 8.
- Sloping peaked-type, if the ceiling slopes in two directions from the highest point. Consider curved or domed ceilings as a peaked ceiling, with the slope figured as the slope of the chord from highest to lowest point.
- Sloping shed-type, if the high point is at one side with the slope extending toward the opposite side.

**Ceiling Height** — is the height from the floor to the ceiling of a room or space.

**Design spacing** — the spacing required for a particular installation.

**Listed spacing** — the spacing for which a heat detector is rated.

**Partitions** — walls extending from the floor toward the ceiling. If they are within 15% of the ceiling, consider the space separated by the partitions as separate rooms.

**Solid joists** — are solid structures that project down from the ceiling surface more than 4 in. (100 mm) and are spaced at intervals of 36 in. (910 mm) or less, center-to-center. Consider solid joists equivalent to beams for smoke detector spacing guidelines.

---

NOTES:

---

# HEAT DETECTOR SPACING

## HEAT DETECTOR SPACING

Do not install heat detectors in areas with an ambient temperature above 100.4° F (38°C). When determining detector placement, consider ceiling height, construction, and ventilation as these affect a detector's performance.

A heat detector's listed spacing rating is based on detector installation on a flat smooth ceiling that is 10 ft. (3 m) high. The spot-type listed spacing equates detector operation with the opening of a standard sprinkler head within 2 minutes ( $\pm 10$  seconds) located 10 ft. (3 m) from the same fire.

Detector spacing is shown in Figure 1 below.

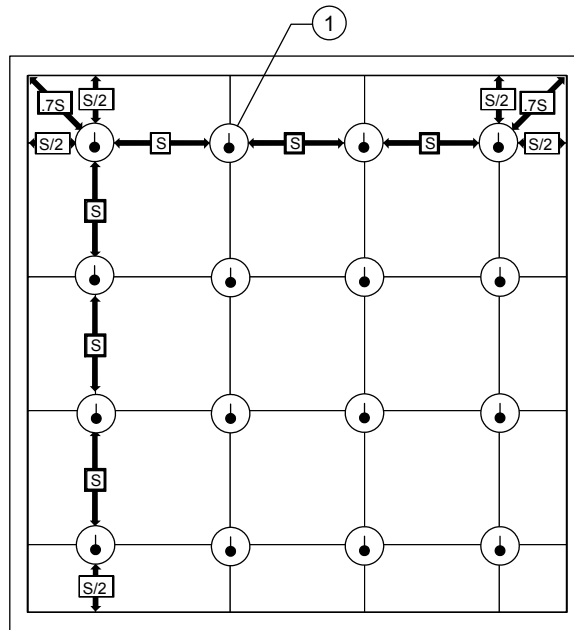

1. Heat detector

Listed spacing between detectors (S) = 50 ft. (15.2 m)

Note: Spacing is dependent on the ceiling height

Figure 1. Listed Spacing for DS-HFS Heat Detector

Detector coverage is typically represented as a square because most structures have flat sidewalls. Actual detector coverage is a circle whose radius is 0.7 times the listed spacing.

The listed spacing for DS-HFS heat detectors is S = 50 ft. (15.2 m).

Figure 2 below shows that the square areas of coverage, A, B, and C, are all within the detector's circle of coverage.

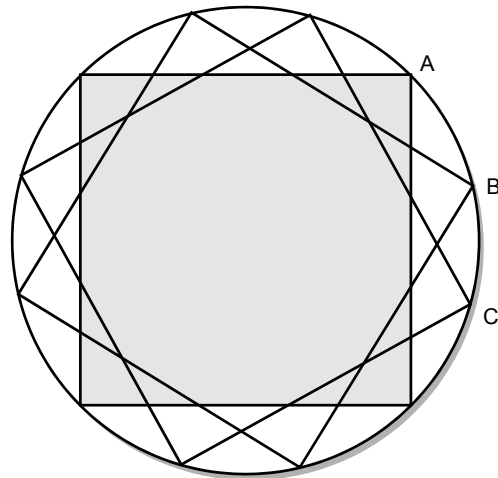
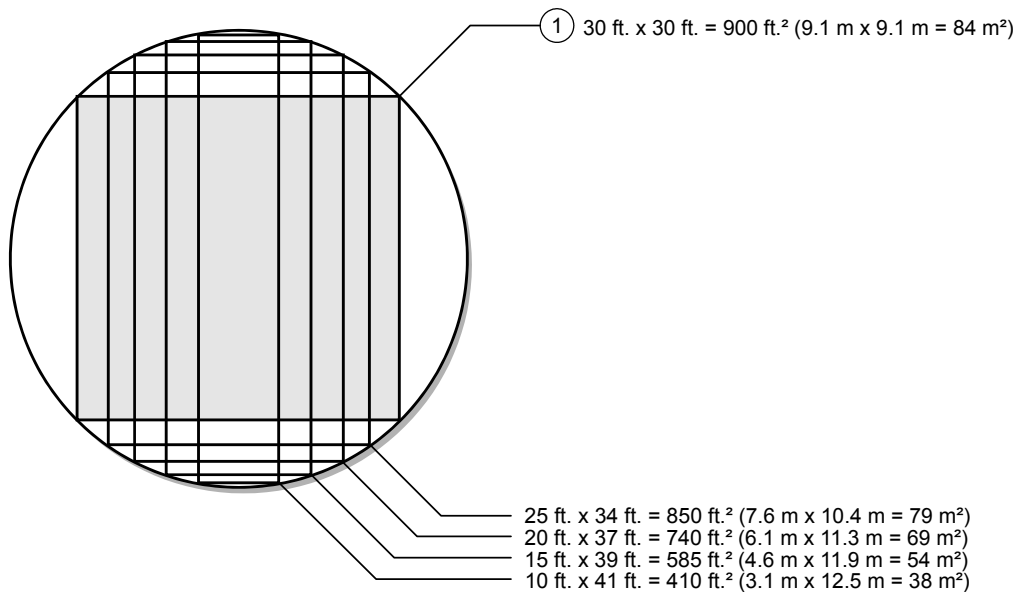

Figure 2. Heat Detector's Circle of Coverage

Since all of the area within the detector's circle of coverage is suitable for detecting a fire, the shape and dimensions of the detector coverage "square" in Figure 3 may be modified. Note that, although the coverage "square" is now a "rectangle," the coverage area remains within the overall detector circle of coverage.



1. Based on 50 ft. listed spacing

Note: Smoke detectors are not listed for spacing

Figure 3. Heat Detector Spacing, Rectangular Areas

When installed on the ceiling, locate the heat detectors a minimum of 4 in. (100 mm) from the wall. When installed on walls, locate the detector between 4 in. (100 mm) and 12 in. (300 mm) from the ceiling, as shown in Figure 4.

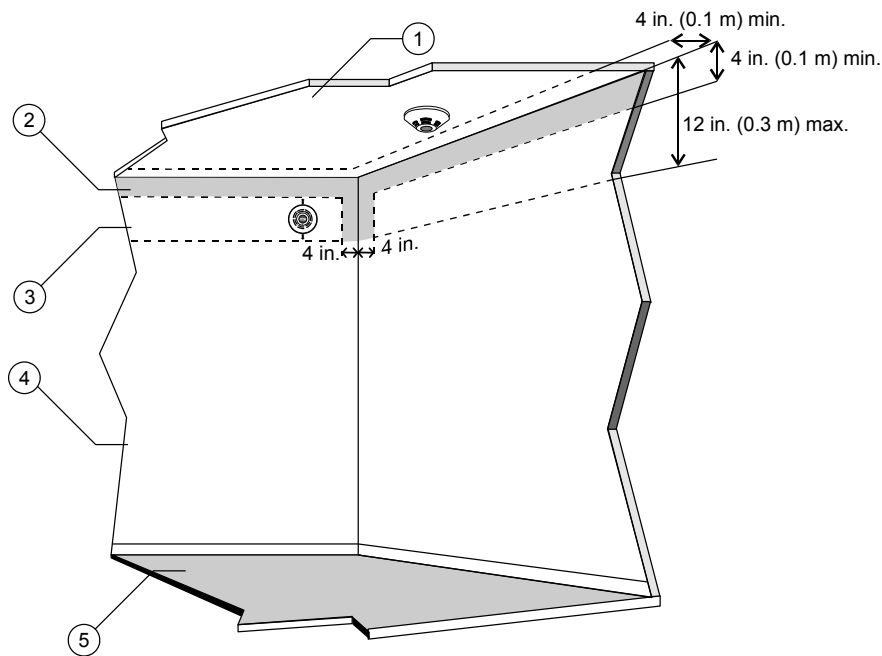

1. Smooth ceiling, place detector 4 in. (100 mm) from wall
2. Never in this area: 4 in. (100 mm) from top of wall or corner
3. Top of detector is acceptable in shaded area: 4 to 12 in. (100 to 300 mm) from ceiling
4. Wall
5. Floor

Figure 4. Heat Detector Placement Near Ceiling/Wall Joints

## Ceiling Height and Construction

Make spacing adjustments when installing DS-HFS heat detectors on other than flat smooth ceilings or at ceiling heights 10 ft. (3 m) to 30 ft. (9.1 m) high. The table below shows the reduction in spacing required when mounting the DS-HFS detector on ceilings higher than 10 ft. (3 m). This reduced spacing yields the equivalent response of detectors located on a 10 ft. (3 m) ceiling. Evaluate ceilings above 30 feet carefully with consideration to the best placement and spacing.

Ceiling height	Percent of listed spacing	Spacing Between DS-HFS Detectors	
0 to 10 ft. (0 to 3.0 m)	100	20.0 ft. (6.0 m)	50.0 ft. (15.3 m)
10 to 12 ft. (3 to 3.7 m)	91	18.2 ft. (5.5 m)	45.5 ft. (13.9 m)
12 to 14 ft. (3.7 to 4.3 m)	84	16.8 ft. (5.1 m)	42.0 ft. (12.8 m)
14 to 16 ft. (4.3 to 4.9 m)	77	15.4 ft. (4.7 m)	38.5 ft. (11.7 m)
16 to 18 ft. (4.9 to 5.5 m)	71	14.2 ft. (4.3 m)	35.5 ft. (10.8 m)
18 to 20 ft. (5.5 to 6.0 m)	64	12.8 ft. (3.9 m)	32.0 ft. (9.8 m)
20 to 22 ft. (6.0 to 6.7 m)	58	11.6 ft. (3.5 m)	29.0 ft. (8.8 m)
22 to 24 ft. (6.7 to 7.3 m)	52	10.4 ft. (3.2 m)	26.0 ft. (7.9 m)
24 to 26 ft. (7.3 to 7.9 m)	46	9.2 ft. (2.8 m)	23.0 ft. (7.0 m)
26 to 28 ft. (7.9 to 8.5 m)	40	8.0 ft. (2.4 m)	20.0 ft. (6.0 m)
28 to 30 ft. (8.5 to 9.1 m)	34	6.8 ft. (2.1 m)	17.0 ft. (5.2 m)

Note: Ceiling heights higher than 30 ft. (9.1 m) exceed the limits of the testing for the requirement of the code.

## Sloping Peaked-Typed Ceilings

In rooms with sloping peaked-typed ceilings (refer to Figure 5), place the first row of DS-HFS detectors within 36 in. (910 mm) horizontally of the peak, but not closer than 4 in. (100 mm) vertically to the peak. Space additional DS-HFS detectors, if required, based upon the horizontal projection of the ceiling and ceiling construction. For a ceiling slope of:

- Less than 30 degrees, space the detectors using the height at the peak.
- Greater than 30 degrees, space the detectors, other than those located in the peak, based on the average slope height or the height of the peak.

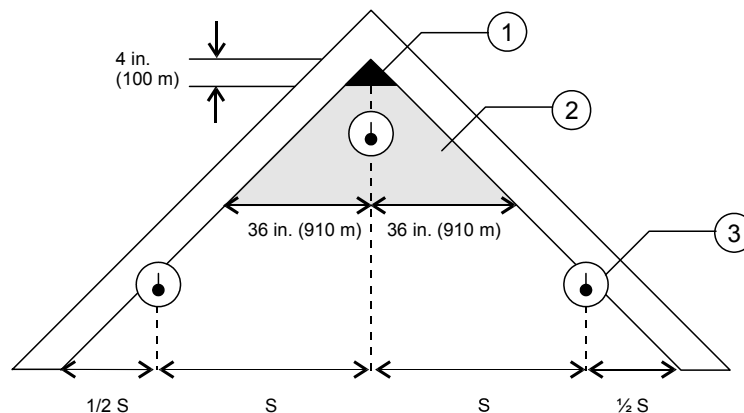

1. Do not mount detector in this area
  2. Mount detector anywhere in this area
  3. Heat or smoke detector
- S = Listed spacing between DS-HFS detectors = 50 ft. (15.2 m)

Figure 5. Heat or Smoke Detector Spacing for Sloping Peaked-Type Ceilings

## Sloping Shed-Typed Ceilings

In rooms with sloped ceilings having a slope greater than 1 ft. in 8 ft. (1 m in 8 m), place the first row of detectors within 36 in. (910 mm) of the high end of the ceiling, but not closer than 4 in. (100 mm) from the adjoining wall or ceiling. (Refer to Figure 6 below.) Space additional detectors, if required, based upon the horizontal projection of the ceiling and ceiling construction.

If the slope is:

- Less than 7.2° (1 in 8), treat the ceiling as a level ceiling
- Less than 30°, adjust the horizontal spacing according to the height of the peak

Greater than 30°, adjust the horizontal spacing according to the average sloped ceiling height or to the height of the peak. This spacing modification for sloped shed-typed ceilings is identical for spot-type heat detectors and smoke detectors.

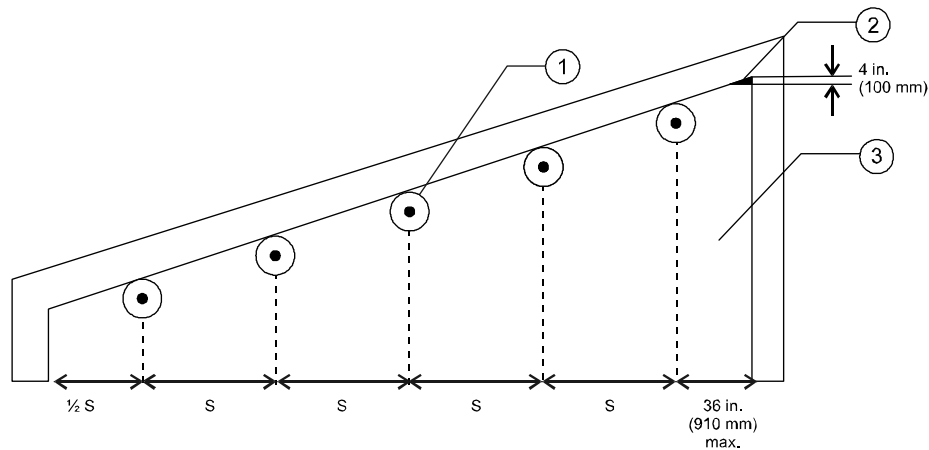

1. Heat or smoke detector
2. Do not mount detector in this area
3. Mount detector anywhere in this area

$S$  = Listed spacing between DS-HFS detectors  
= 50 ft. (15.2 m)

Figure 6. Heat or Smoke Detector Spacing for Sloping Shed-Typed Ceilings



## Solid Joists

When spacing heat detectors at right angles to the solid joists, do not exceed 50-percent of the listed spacing and mount the detectors at the bottom of the joists.

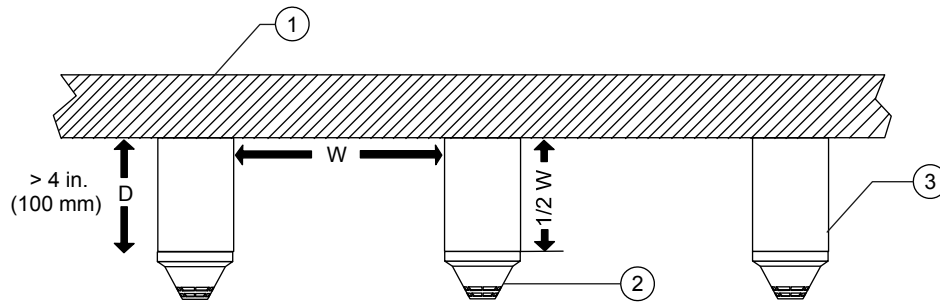

- |                          |             |          |
|--------------------------|-------------|----------|
| D. Depth                 | 1. Ceiling  | 3. Joist |
| W. Spacing between joist | 2. Detector |          |

Figure 7. Heat Detector Spacing for Solid Joists

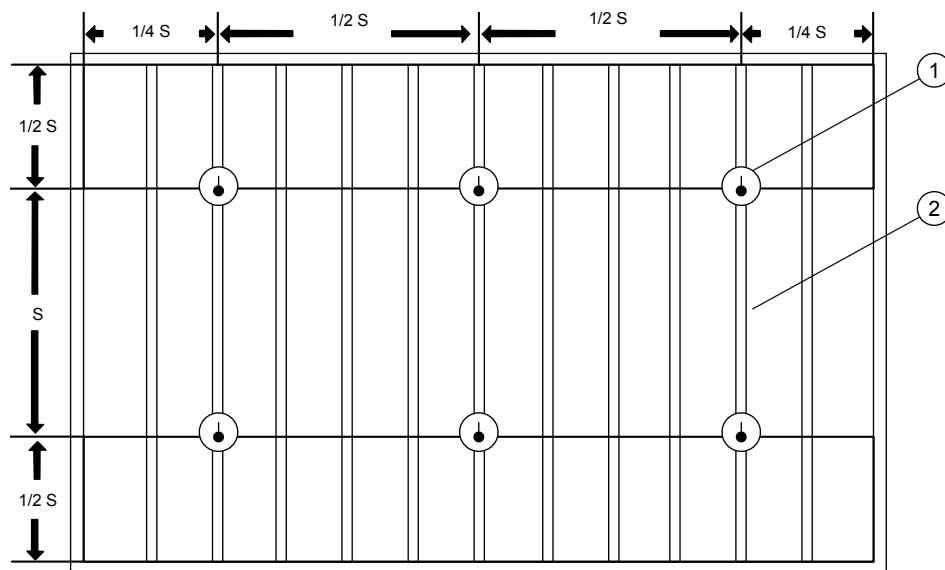

- |                  |   |
|------------------|---|
| 1. Heat detector | S = Listed spacing between DS-HFS detectors |
| 2. Joist         | = 50 ft. (15.2 m)                           |

Figure 8. Reduced Heat Detector Spacing for Solid Joists Construction

## Exposed Beams

Exposed beams may impede the flow of fixed temperature heat detectors. Beams are defined as solid structures extending 4 in. (100 mm) or more down from the ceiling. Beam spacing depends on the depth of projection from the ceiling and the center-to-center spacing between the beams.

If the beams project:

- Less than or equal to 4 in. (100 mm) below the ceiling, mount the detector on the ceiling with normal ceiling spacing. See Figure 9, item 1.
- More than 4 in. (100 mm) below the ceiling, mount the detector on the ceiling. Do not exceed 66% of the listed spacing at right angles to the beam direction. Treat the spacing in the direction parallel to the beams separately. See Figure 9, item 2.
- Less than 12 in. (300 mm) in depth and are spaced less than 96 in. (2.44 m) on center, mount the detectors on the bottom of the beams. See Figure 9, item 3.
- Greater than 18 in. (460 mm) below the ceiling and are more than 96 in. (2.44m) on center, treat each bay created by the beams as a separate area. See Figure 9, item 4.
- For additional details, see NFPA 72.

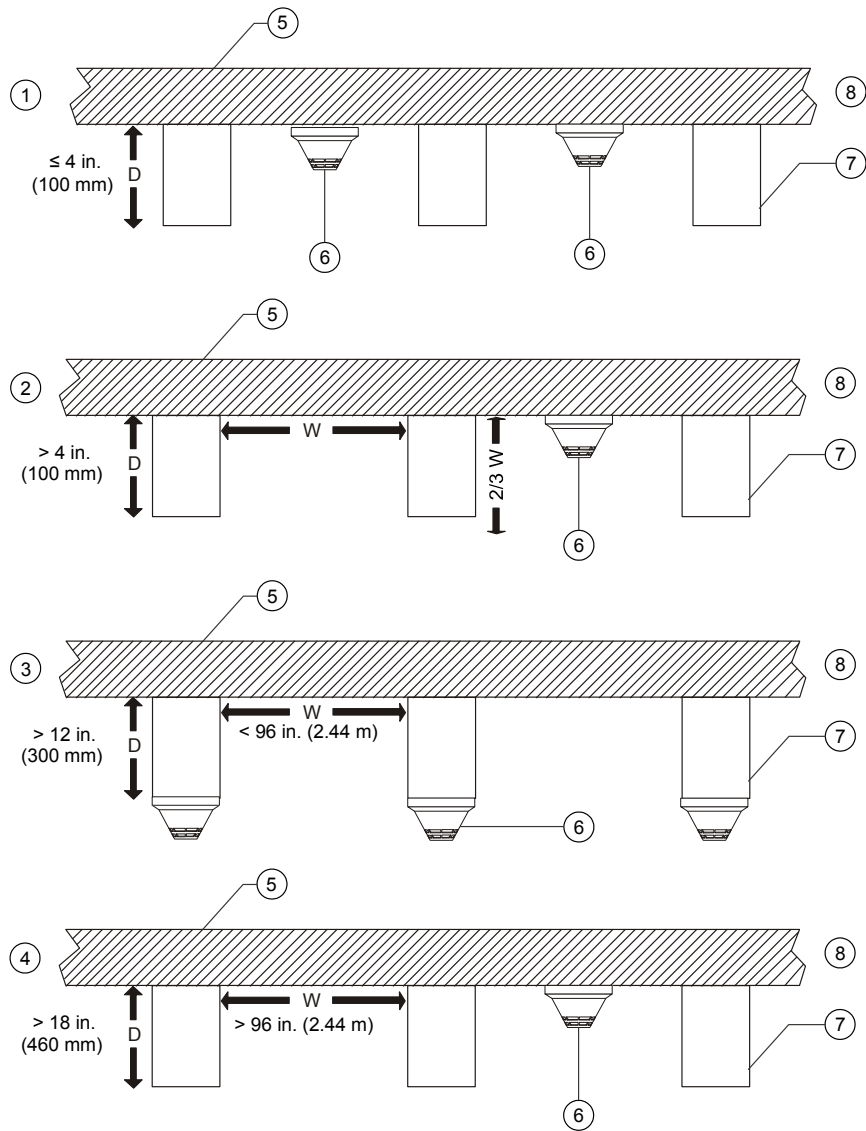

- |                         |                           |                    |
|-------------------------|---------------------------|--------------------|
| D = Depth of beam       | 3. D = > 12 in (300 mm),  | 5. Ceiling Section |
| W = Beam spacing        | W = < 96 in. (2.4 m)      | 6. Heat detector   |
| 1. D = ≤ 4 in. (100 mm) | 4. D = > 18 in. (460 mm), | 7. Solid beam      |
| 2. D = > 4 in. (100 mm) | W = > 96 in. (2.4 m)      | 8. Side view       |

Figure 9. Heat Detector Spacing for Beam Construction

---

# **SMOKE DETECTOR SPACING**

## SMOKE DETECTOR SPACING

The DS-PS spot-type smoke detector spacing recommendation of 30 ft. (9.1 m)  $\pm$ 5% or 18 in. (460 mm) is based upon the detector installation on a smooth ceiling that is 10 ft. (3 m) high. Detector coverage is typically represented as a square, because most structures have flat sidewalls. Like spot-type heat detectors, smoke detector coverage is a circle whose radius is 0.7 times the listed spacing. Since all of the area within the detector's circle of coverage is suitable for detecting smoke from fire, the shape and dimensions of the detector coverage "square" may be modified. Note that, although the coverage "square" is a "rectangle," the coverage area is within the overall detector circle coverage. (Refer to Figure 3.)

**Note:** Unlike heat detectors, smoke detectors are not given a listed spacing. It is recommended that smoke detectors be installed on  $S = 30$  ft. (9.1 m)  $\pm$ 5% or 18 in. (460 mm) installed on "x" centers, on smooth ceilings. NFPA 72, National Fire Alarm and Signaling Code contains additional information regarding spacing adjustments.

### Ceilings and Walls

Locate smoke detectors on the ceiling or, if on a sidewall, between the ceiling and 12 in. (300 mm) down from the ceiling to the top of the detector.

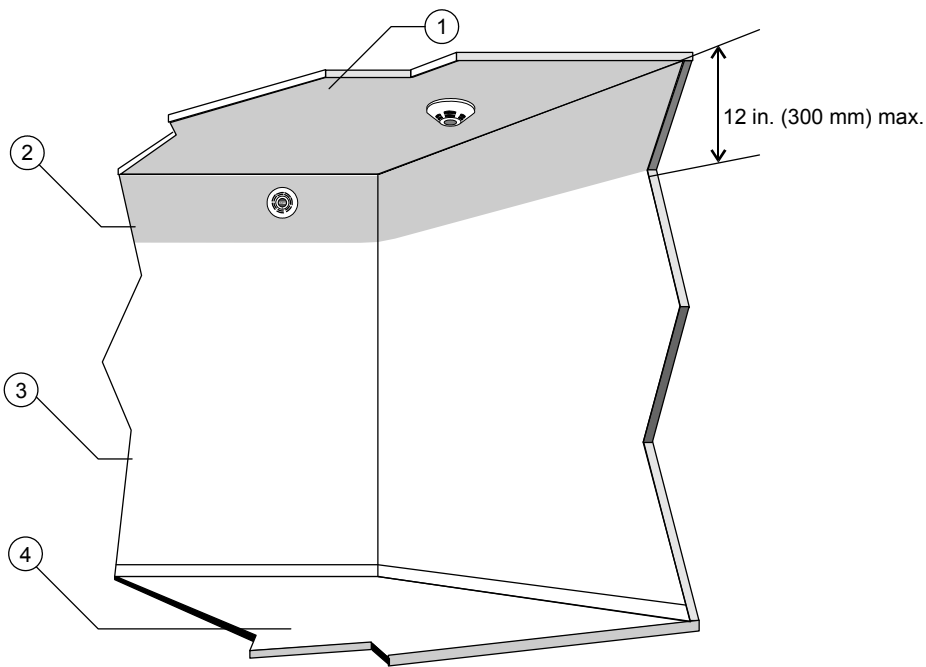

- |   |          |
|---|----------|
| 1. Smooth ceiling                             | 3. Wall  |
| 2. Top of detector is acceptable in this area | 4. Floor |

Figure 10. DS-PS Smoke Detector Placement Near Ceiling/Wall Joints

For a smooth ceiling, for every point on the ceiling, locate the detector within a horizontal measurement no greater than 0.7 times the selected spacing.

## Beams and Solid Joists

For smoke detector spacing, solid joists are considered equivalent to beams.

For ceilings with a beam or solid joist depth less than 10 percent of the ceiling height (0.1 H), mount the detectors on the bottom of beams.

For ceilings with a beam or solid joist depth equal to or greater than 10 percent of the ceiling height (0.1 H) and a beam spacing equal to or greater than 40 percent of the ceiling height (0.4 H), locate the detectors on the ceiling in each beam pocket.

For ceilings with a beam depth equal to or greater than 10 percent of the ceiling height (0.1 H) and a beam spacing less than 40 percent of the ceiling height (0.4 H), locate the detectors either on the bottom of the beams or on the ceiling at smooth ceiling spacing in the direction parallel to the beams and at one-half smooth ceiling spacing in the direction perpendicular to the beams.

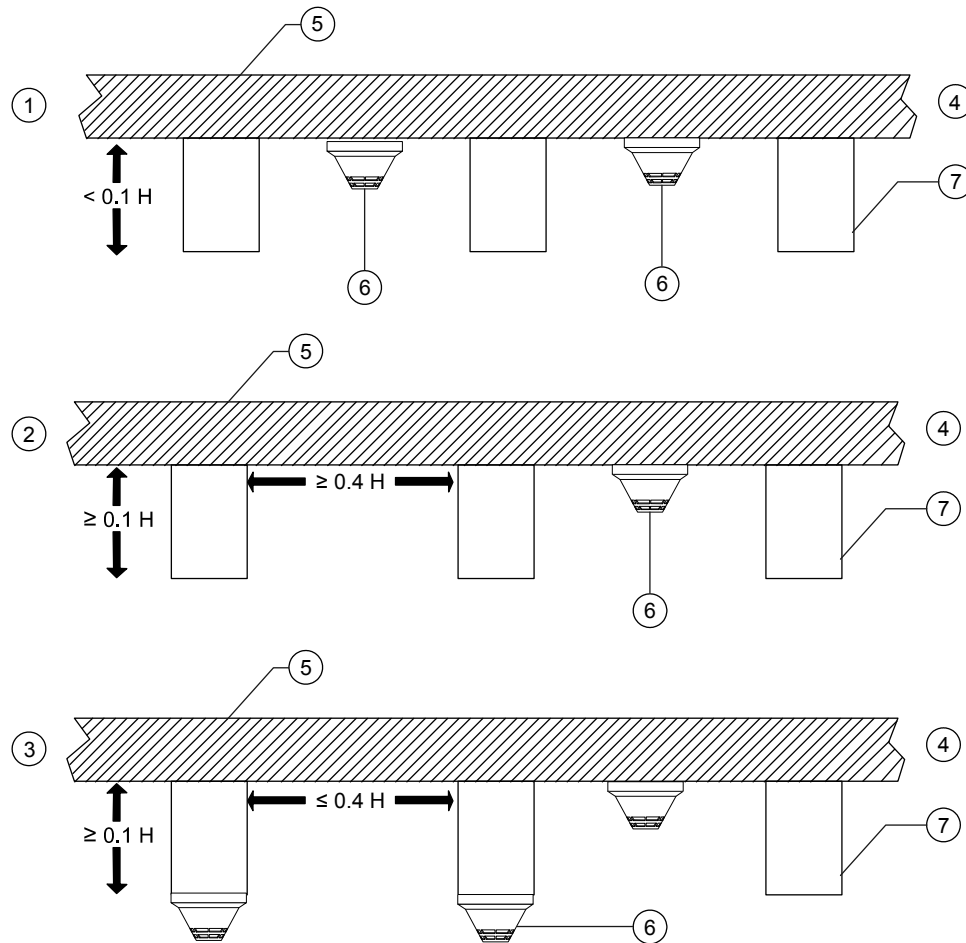

H = Ceiling Heights

1.  $< 1.0 H$

2.  $\geq 0.1 H$  and  $\geq 0.4 H$

3.  $\leq 0.1 H$  and  $\geq 0.4 H$

4. Side view

5. Ceiling Section

6. Heat detector

7. Solid beam

Figure 11. Smoke Detector Spacing for Beam Construction

## Sloping Ceilings with Beams

For sloping ceilings with beams running parallel up the slope:

- Locate the smoke detectors on the ceiling within the beam pockets.
- The ceiling height is the average height over slope.
- To determine the detector spacing, measure along the horizontal projection of the ceiling.
- Smooth ceiling spacing is permitted within beam pocket(s) parallel to the beams.
- For beam depths less than or equal to 10 percent of the ceiling height ( $0.1 H$ ), locate the detectors with smooth ceiling spacing perpendicular to the beams.
- For beam depths greater than 10 percent of the ceiling height ( $0.1 H$ ) and beam spacing greater than or equal to 40 percent of the ceiling height ( $0.4 H$ ), locate the detectors in each beam pocket.
- For beam depths greater than 10 percent of the ceiling height ( $0.1 H$ ) and beam spacing less than 40 percent of the ceiling height ( $0.4 H$ ), smoke detectors are not required in every beam pocket but must be spaced not greater than 50 percent of smooth ceiling spacing.

## Sloping Ceilings with Intersecting Beams

For sloped ceilings with beam pockets formed by intersecting beams, position the detectors on the bottom of perpendicular beams and align them with the center of the pocket. See Figure 12.

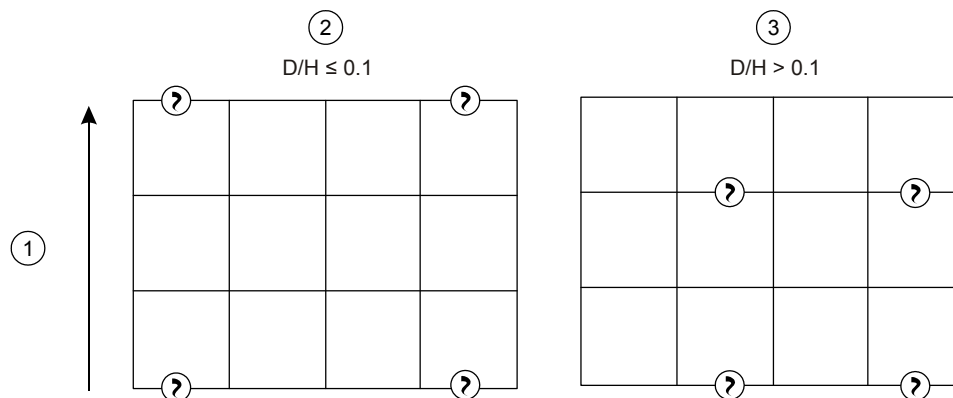

② Smoke detector

D = Beam depth

H = Average ceiling height over slope

1. Upslope
2. Place the detectors with not more than three beams between detectors and not exceeding the smooth ceiling spacing
3. Place the detectors with not more than two beams between detectors and not exceeding the 50-percent of the smooth ceiling spacing

Figure 12. Spacing for Sloping Ceilings with Beam Pockets Formed by Intersecting Beams

## Sloping Peaked-Typed Ceilings

In rooms with sloping peaked-type ceilings, place the first row of detectors within 3 ft. (1 m) (horizontally) of the ceiling peak. Space additional detectors, if required, based upon the horizontal projection of the ceiling and ceiling construction. This modification of spacing for smoke detectors on sloped ceilings is identical to that used for spot-type heat detectors. Refer to Figure 5.

In rooms with sloping shed-typed ceilings having a slope:

- Less than a 1 ft. in 8 ft. (1 m in 8 m) rise, treat as a level ceiling.
- Greater than a 1 ft. in 8 ft. (1 m in 8 m) rise, place the first row of detectors within 36 in. (910 mm) of the high end of the ceiling. Space additional detectors, if required, based upon the horizontal projection of the ceiling and ceiling construction.
- Less than 30 degrees, adjust the horizontal spacing according to the height of the peak.
- Greater than or equal to 30 degrees, adjust the horizontal spacing according to the average sloped ceiling height.

This spacing modification for smoke detectors on sloped ceilings is identical to that used for spot-type heat detectors. Refer to Figure 6.

## Under-Floor Installation

When spot-type smoke detectors are installed under raised floors, they are subjected to high air velocities and dust levels. Install the detectors with the base up or the base vertical (never down) as shown in Figure 13 below. This minimizes the effects of dirt, dust, and mechanical interference from cabling.

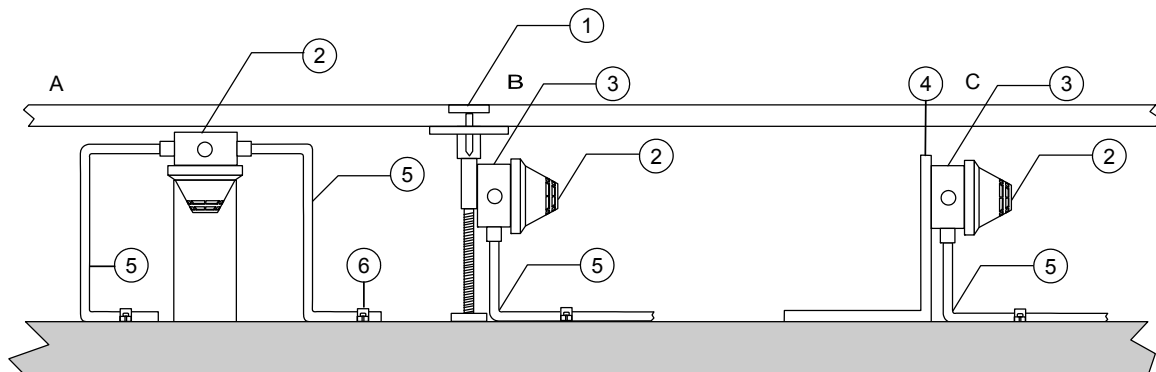

- |  |                       |                                   |
|--|-----------------------|-----------------------------------|
| A. Junction box secured to structure                     | 1. Raised floor panel | 4. Steel angle or channel support |
| B. Junction box secured to floor support                 | 2. Smoke detector     | 5. EMT or FMC conduit             |
| C. Junction box secured to angle iron or channel support | 3. Junction box       | 6. Clamp                          |

Figure 13. Permissible Smoke Detector Placement Under Raised Floors

## Stratification and Spacing Compensation

Stratification occurs when the upward movement of smoke and gases ceases due to the loss of buoyancy of heated smoke. Stratified air within a room may impede smoke reaching the detector. To improve detection system response in situations where stratification exists, install additional detectors at elevations below ceiling level as shown in Figure 14. For additional information, refer to NFPA 72, Annex B.

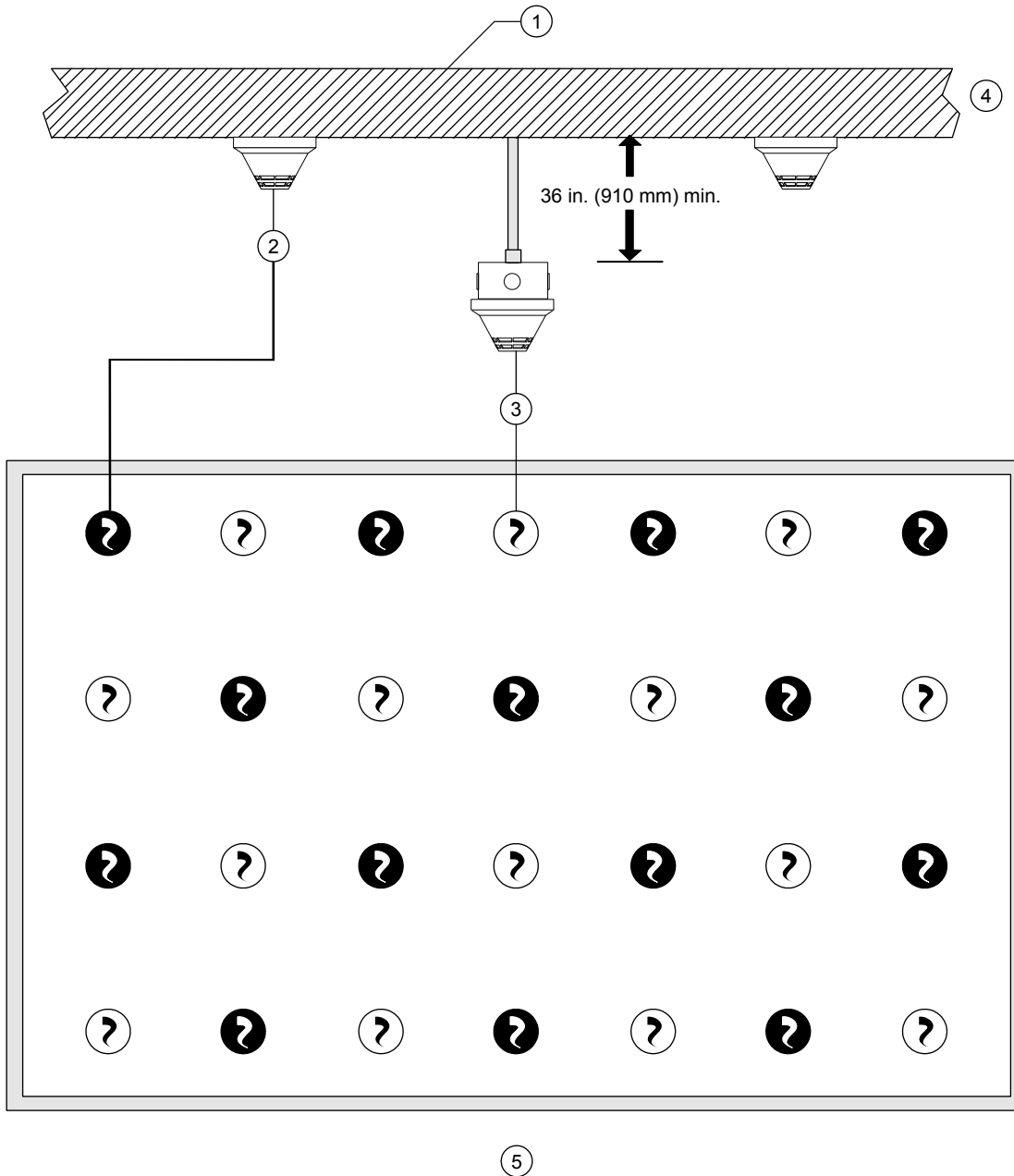

- |                                  |              |
|----------------------------------|--------------|
| 1. Ceiling section               | 4. Side view |
| 2. Smoke detector, at ceiling    | 5. Plan view |
| 3. Smoke detector, below ceiling |              |

Figure 14. Smoke Detector Compensation for Stratification



---

## Smoke Detector High Air Movement

The use of spot-type smoke detectors in areas of high air movement (greater than 300 ft./min [1.5m/sec]) requires a suitable reduction in detector spacing to maintain detector performance. Use the table below to determine the reduced detector spacing in these areas. This table is not valid for use under floor or in ceiling plenum areas, however, the principle of reduced spacing in these high-velocity areas applies.

Table 2. High Airflow Area Detector Spacing Reduction

Minutes per air change	Number of air changes per hour	Coverage per detector
1	60	125 ft. <sup>2</sup> (12 m <sup>2</sup> )
2	30	250 ft. <sup>2</sup> (23 m <sup>2</sup> )
3	20	375 ft. <sup>2</sup> (35 m <sup>2</sup> )
4	15	500 ft. <sup>2</sup> (46 m <sup>2</sup> )
5	12	625 ft. <sup>2</sup> (58 m <sup>2</sup> )
6	10	750 ft. <sup>2</sup> (70 m <sup>2</sup> )
7	8.6	875 ft. <sup>2</sup> (81 m <sup>2</sup> )
8	7.5	900 ft. <sup>2</sup> (84 m <sup>2</sup> )
9	6.7	900 ft. <sup>2</sup> (84 m <sup>2</sup> )
10	6	900 ft. <sup>2</sup> (84 m <sup>2</sup> )

## Effects of Heating, Ventilating, and Air Conditioning (HVAC) Systems

Because airflow is critical to the transportation of smoke to the detector location, never locate smoke detectors closer than 36 in. (910 mm) to an HVAC supply diffuser or return air opening. Higher velocity intake and return grills may require additional clearance.

**Note:** Do not rely on the operation of the HVAC system when spacing smoke detectors.

---

NOTES:

---

# HEAT DETECTOR APPLICATIONS



**According to independent studies, use heat detectors only for property protection. Never rely on heat detectors as the sole means of fire protection.**

Heat detectors sense change in air temperature and initiate alarm conditions based on a fixed-temperature point, rate of temperature rise, or amount of temperature rise above ambient condition.

The DS-HFS heat detector is a spot-type detector. Spot-type heat detectors have a detecting element or elements that respond to temperature conditions at a single point or in a small area. The fixed temperature detectors respond when the detecting element becomes heated to a predetermined level.

DS-HFS detectors are best suited for detecting fast, flaming fires such as open wood and liquid fires without smoke.

Heat detectors do NOT:

- Operate without electrical power. As fires frequently cause power interruption, discuss further safeguards with the local fire protection specialist.
- Sense fires in areas where heat cannot reach the detector. Heat from fires in walls, roofs, or on the opposite side of closed doors may not reach the detector.
- Provide, by themselves, life safety protection. Use heat detectors with photoelectric smoke detectors.
- Detect oxygen levels, smoke, toxic gases, or flames. Use these devices as part of a broad-based life safety program which includes a variety of information sources pertaining to heat and smoke levels, extinguishment systems, visual and audible devices, and other safety measures.

Table 3. Suitability of DS-HFS Heat Detector for Various Applications

<b>Type of Fire</b>	<b>Suitability of detectors</b>
Open wood	Optimal
Wood pyrolysis	Unsuitable
Smoldering cotton	Unsuitable
PU foam	Suitable
N-heptane	Very Suitable
Liquid fire without smoke	Optimal

---

# **SMOKE DETECTOR APPLICATIONS**

---

Regardless of the principle of operation, smoke detectors sense the presence of smoke particles. In order for a smoke detector to sense these particles, smoke must travel from the point of origin to the detector.

When evaluating a particular building or location for detector layout, determine likely fire locations and paths of smoke travel from each of these fire locations. Wherever practical, conduct actual field tests. The most desired location for smoke detectors is the common points of intersection of smoke travel from fire locations throughout the building. Ceiling height, construction, and ventilation play significant roles in smoke detector performance.

The DS-PS photoelectric smoke detector has a wide range of fire sensing capabilities and is best suited for detecting slow, smoldering fires such as wood pyrolysis and smoldering cotton.

Table 4. Suitability of DS-PS Photoelectric Detector for Various Applications

Type of Fire	Suitability of detector
Open wood	Unsuitable
Wood pyrolysis	Optimal
Smoldering cotton	Optimal
PU foam	Very Suitable
N-heptane	Very Suitable
Liquid fire without smoke	Unsuitable

### Avoidance of False Alarms

Smoke detectors are sensitive to a number of environmental factors (other than smoke), which may inadvertently activate the detectors. Careful consideration of the environment in which a detector is installed minimizes unwanted detector activation (nuisance alarms). When locating smoke detectors, consider common sources of false alarms:

- Cooking equipment
- Welding, cutting, and industrial processes
- Chemical fumes
- Dust
- Engine exhaust
- Vibration
- Excessive airflow
- Lightning and power outages
- Lighting fixture and other electrical equipment that may emit noise/EMF
- Radio frequency transmissions
- Steam and moisture

**Note:** The DS-PS smoke detector provides automatic environmental compensation, which reduces the occurrence of false alarms by allowing sensing elements to adapt to long-term environmental changes, caused by dirt, smoke, temperature, and humidity.

---

# **AIR DUCT SMOKE DETECTOR APPLICATIONS**

## Controlling Smoke Spread

Smoke detectors placed in air ducts or plenums are not substitutes for open area smoke detectors.



**Do not place heat detectors in air ducts.**

Install the DS-PS detector in front of or behind the opening in return ducts. When the duct height exceeds 36 in. (91 cm), space the detectors per Table 5 below.

Table 5. Location of Spot-Type Detectors in Return Air Duct Openings

Duct Size*	Detector placement
Up to 36 in. (910 mm)	One detector centered in the duct opening
Up to 72 in. (1.83 m)	Two detectors located at the 1/4 points of the duct opening
Over 72 in. (1.83 m)	One additional detector for each full 24 in. (610 mm) of duct opening

\* **Note:** Duct size is the greater of the width (horizontal dimension) or depth (vertical dimension)

1. Rigidly mount the detector within the air duct.
2. Permanently mark all duct detector locations and ensure that they are accessible for cleaning and maintenance. See Figure 15 below.

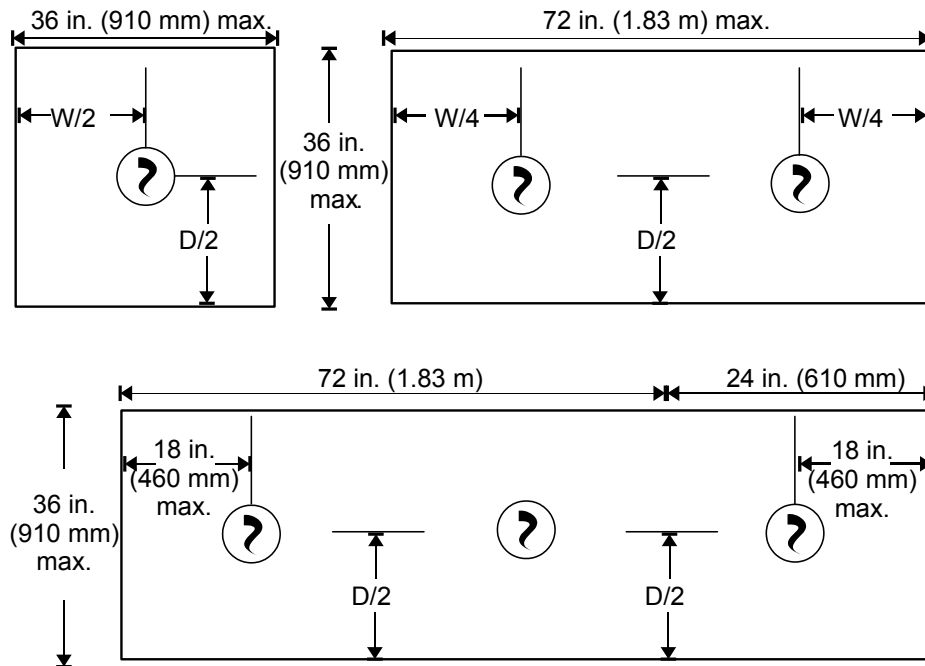

W Width  
 D Depth  
 ? Smoke detector

**Note:** One detector is required for each full 24 in. (610 mm) of additional opening width.

**Note:** Keep the detectors spaced equally apart.

Figure 15. Smoke Detector Spacing in Return Ducts



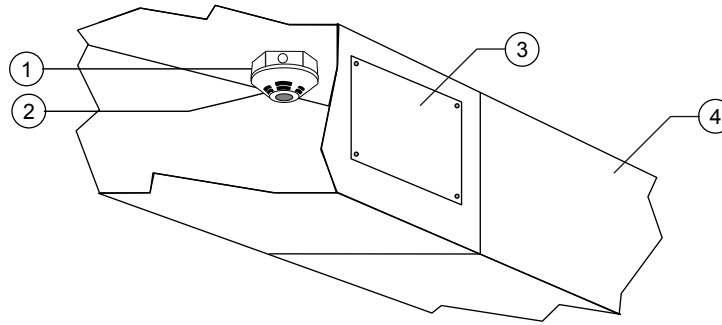

- |                   |                      |
|-------------------|----------------------|
| 1. Electrical box | 3. Access panel door |
| 2. Detector       | 4. Air duct          |

Figure 16. Smoke Detector Location in Return Ducts

### Duct Detector Mounting Plate (SIGA-DMP)

The SIGA-DMP Duct Detector Mounting Plate is a 7 in. (178 mm) square mounting plate with a 4 in. (100 mm) square electrical box used to directly mount a DS-PS smoke detector inside an air duct. The SIGA-DMP includes screws for mounting the DS-SB or DS-RB detector base and a rubber gasket that forms an airtight seal between the mounting plate and the air duct wall. See Figure 17 below.

**Note:** Do not use with heat detectors.

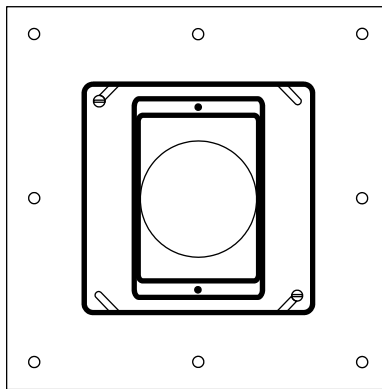

Figure 17. The SIGA-DMP Duct Detector Mounting Plate for DS-PS Smoke Detector

- Install the SIGA-DMP in ducts that have a maximum width and maximum height of 36 in. (910 mm).
- The compatible smoke detector is the DS-PS. Compatible bases include the DS-SB and DS-RB.
- Acceptable air velocity range is 300 - 4,000 ft./min (1.52 to 20.32 m/s).

## Installation of the SIGA-DMP Duct Detector Mounting Plate

To install a DS-PS smoke detector with SIGA-DMP plate onto an air duct:

1. Cut out an area on the air duct in an easily accessible, clearly visible location.
2. Mount the detector base to the SIGA-DMP plate and:
  - a. Connect system loop wiring to the detector base.
  - b. Attach the detector head to the detector base.
3. Attach the SIGA-DMP assembly to the air duct.
4. Install the SIGA-DMP blank cover to the SIGA-DMP plate (shipped with SIGA-DMP kit).
5. Perform initial installation testing.
6. Perform functional testing.

**Note:** The DS-PS Photoelectric Detector is not compatible with the SIGA-LED Remote Alarm LED.

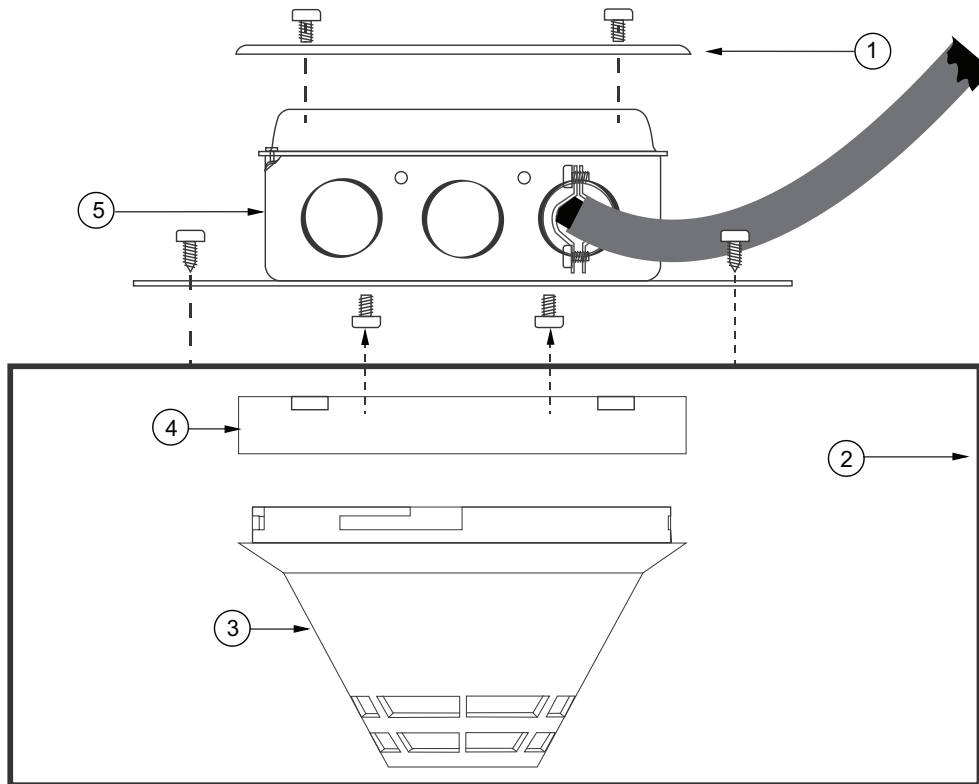

- |   |  |
|---|--|
| 1. Blank cover plate                              | 3. DS-PS detector                        |
| 2. Air duct wall thickness: 0.75 in. (19 mm) max. | 4. DS-SB or DS-RB base                   |
|   | 5. SIGA-DMP duct detector mounting plate |

Figure 18. Installation of the SIGA-DMP

---

# TESTING AND MAINTENANCE

---

## DS-PS Smoke Detector and DS-HFS Heat Detector Testing and Maintenance

To ensure proper operation of detectors, plan maintenance in accordance with the requirements of the Authority Having Jurisdiction. Refer to NFPA 72 *National Fire Alarm and Signaling Code*, CAN/ULC-S536, *Standard for the Inspection and Testing of Fire Alarm Systems*, and CAN/ULC-S537 *Standard for the Verification of Fire Alarm Systems*.

### Initial Installation Testing



Before testing, notify the proper authorities that the fire alarm system is undergoing maintenance and will be temporarily out of service.



All notification appliances, releasing devices and extinguishing systems should be disengaged during testing and reengaged at the conclusion of testing.



Do not attempt any testing or maintenance of the system until you have:

- Isolated all system releasing outputs via the Isolate function, including Remote Releasing Modules (RRMs).
- Physically disconnected the wiring to actuator assemblies (if used) from the release-circuit terminals, shorted the leads together, and wrapped the leads in insulating tape
- Physically disconnected all control heads (if used) from their associated agent-storage-container discharge valves
- Physically disconnected the wiring to solenoid valves (if used) for pre-action/deluge sprinkler systems
- Ensured that emergency operations controlled by this system such as facility power shut-off are bypassed

To perform an initial installation test:

1. Visually inspect each detector and verify it is installed in the correct location. Make sure it will not be adversely affected by factors not apparent on the plans.
2. Remove dust cover from detector head.
3. Remove the detector from its base and verify that the proper detector address, trouble signals, and messages are reported. Return the detector to the base.
4. Activate smoke detectors using a chemical smoke aerosol spray (P/N SM200-12PKG or equivalent) or a smoke generator.
5. Verify that adequate airflow is available for air duct detectors.
6. If wired for Class A operation, verify operation with SLC\_IN disconnected and then SLC\_OUT disconnected.
7. Place a momentary ground on the SLC circuit and verify operation of ground fault detection circuitry.
8. For the DS-PS detector, execute the control unit **LIST MENU>Device Readings/SLC Device** command and enter the address of the detector just installed. Verify the values which are set for Alarm and Pre-Alarm conditions. Use a chemical smoke aerosol spray or smoke generator on the detector and confirm that real-time smoke readings fall within acceptable limits..
9. Visually inspect the state of the LED:
  - Normal: Green LED indicator flashes, no action required.
  - Alarm/active: Red LED indicator flashes, evacuate the area.

---

## Routine Maintenance

Detectors should be tested on a routine basis satisfactory with the Authority Having Jurisdiction, typically once every 6 months.

To perform routine maintenance:

1. Verify detector operation, wiring integrity, and control unit operation sequences specific to that detector.
2. For step 3, disconnect all releasing outputs per warnings on previous page.
3. For the DS-PS detector, execute the control unit **LIST MENU>Device Readings/SLC Device** command and enter the address of the detector. Use a chemical smoke aerosol spray or smoke generator on the detector and confirm that real-time smoke readings fall within acceptable limits. Clean detectors that are too close to the alarm threshold according to the procedure below.

## Cleaning the DS-PS Smoke Detector

To clean the DS-PS detector:

1. Disable the detector to prevent false alarms.
2. Disconnect all releasing outputs per warnings on previous page.
3. Use a conventional vacuum cleaner brush to remove visible cobwebs, etc. from the immediate area of the detector.
4. Remove the detector from the detector base by inserting a small screwdriver into the tamper-resist access slot while rotating the detector counterclockwise. Refer to Figure 19 for pry location points.
5. Push the locking tab on the bottom of the detector toward the center, and then twist and pull to remove the cover.
6. Using a soft brush and vacuum, carefully remove any dust or dirt from around the sensor chambers.
7. After the detector has been cleaned, reassemble and restore it to proper operation.
8. Operate the detector for a minimum of two hours, then reset the system. Verify that the LED indicator flashes green and any related control unit faults clear.
9. With the detector re-installed and the system reset, the system should only show trouble conditions for open releasing outputs. Releasing outputs can then be reconnected to the system.
10. Once all releasing outputs have been reconnected, verify that all trouble conditions have cleared.
11. If a drift error had been reported, note that it will take time for that message to clear after the detector has been cleaned.
12. If the drift error does not clear after several hours, replace the smoke chamber and test again.

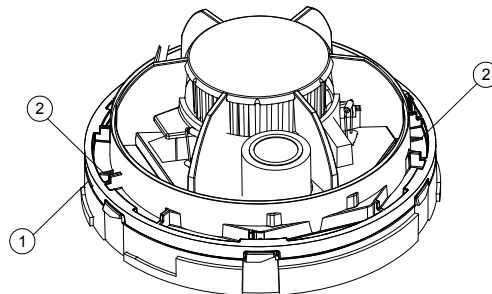

1. Pry Locator
2. Pry Location Point

Figure 19. Access Slots for Screwdriver

## Replacing the DS-PS Smoke Chamber (P/N 2-SPRC1)

To replace the smoke chamber:

1. Disconnect all releasing outputs per warnings on page 34.
2. Remove the detector from the detector base by inserting a small screwdriver into the tamper-resist access slot while rotating the detector counterclockwise.
3. Remove the cover by pushing the releasing tab on the bottom of the detector toward the center, and then twisting and pulling the cover.
4. Remove the inner chamber or smoke chamber by locating the pry indicators, inserting a screwdriver into the pry locations, and then gently prying the chamber up. Refer to Figure 19 for pry location points



**This product contains components that are sensitive to static electricity. Use approved handling precautions to prevent damage from electrostatic discharge.**

5. Insert the replacement smoke chamber.
6. Align the slots on the cover with the tabs on the detector and press to seat and lock the cover.
7. Connect the detector to the detector base by rotating the detector clockwise until it snaps into the locked position.
8. Operate the detector for a minimum of two hours, then reset the system. Verify that the LED indicator flashes green and any related control unit faults clear.
9. With the detector re-installed and the system reset, the system should only show trouble conditions for open releasing outputs. Releasing outputs can then be reconnected to the system.
10. Once all releasing outputs have been reconnected, verify that all trouble conditions have cleared.

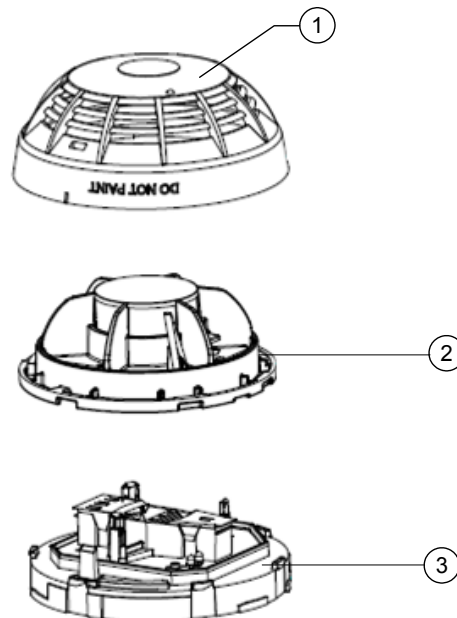

1. Detector Cover: twist and pull to remove
2. Smoke Chamber
3. Base

Figure 20. Replacing the DS-PS Smoke Chamber

---

## Testing the Heat Detector

1. Visually inspect the detector. Verify that the green LED flashes green.
2. Disconnect all releasing outputs per warnings on page 34.
3. Hold the heat gun (1200- to 1500-watt commercial hair blow dryer recommended) directed towards the heat entry slots, maintaining a 6 in. (152 mm) minimum distance. Turn onto highest setting.



**Do not apply excessive heat when using a heat gun or blow dryer. Excessive heat may damage outer cover.**

4. The detector should alarm within 10 to 15 seconds.
5. Verify that a detector activation indication is shown on the control unit.
6. Reset the system, and confirm that all alarm signals have cleared.
7. Once the alarms are cleared, and the system shows only trouble conditions for open releasing outputs, the releasing outputs can be re-connected to the system.
8. Once all releasing outputs have been reconnected, verify that all trouble conditions have been cleared.

---

NOTES:





---

For additional information on the installation and wiring of DS Series detectors and bases, refer to Installation Instructions 06-237507-001 and the Installation, Operation and Maintenance Manual for your control unit, available on the company website.

**EXPORT INFORMATION (USA)**

Jurisdiction: EAR  
US ECCN: EAR99

This document does not contain any export controlled technical data.

SmartOne is a registered trademark of Kidde-Fenwal Inc. All other trademarks are the property of their respective owners.

This literature is provided for informational purposes only. KIDDE-FENWAL, INC. assumes no responsibility for the product's suitability for a particular application. The product must be properly applied to work correctly. If you need more information on this product, or if you have a particular problem or question, contact Kidde-Fenwal Inc.



06-237533-001 Rev AB  
Application Guide K-76-1000

©2016 Kidde-Fenwal, Inc.

Kidde Fire Systems  
400 Main Street  
Ashland, MA 01721  
Ph: 508.881.2000  
Fax: 508.881.8920  
[www.kiddefiresystems.com](http://www.kiddefiresystems.com)