



Elite-RS® Panel Installation Manual



Underwriters Laboratories (UL)

File number (S 8485)

Fire Alarm Equipment

VES, LLC

The VES Elite-RS Panel is suitable as follows:

- Local Signaling Unit
- Releasing for eLAN-RS Panels only. Non-Releasing for Elite-RS Panels.
- Types of signaling services are automatic fire alarm, manual fire alarm, waterflow alarm and sprinkler supervisory.
- Style 4, 6 or 7 for Signaling Line Circuits
- Style Y for Notification Appliance Circuits
- Non-coded Signaling, DACT requires Integrated Dialer
- Remote Station (RS) Protected Premises Unit (PPU) provides releasing, non-releasing and VESNet communication on models (VFXX24, VFXX44, VFXX04) containing the Modem-DACT Ethernet (VFYY04, VFYY05, VFYY08, VFYY09), integrated Dialer or on models (VFXX21, VFXX41, VFXX01) containing the Media Gateway
- Central Station (CS) Protected Premises Unit (PPU) provides releasing, non-releasing and VESNet communication on models (VFXX24, VFXX44, VFXX04) containing the Modem-DACT Ethernet (VFYY04, VFYY05, VFYY08, VFYY09), Integrated Dialer or on models (VFXX21, VFXX41, VFXX01) containing the Media Gateway
- Models (VFXX22, VFXX42, VFXX02) containing the NIC, must be connected (networked) to the VESNet with models (VFXX21, VFXX41, VFXX01) containing the Media Gateway to communicate to a Remote Station Protected Premises Unit, Proprietary Protected Premises Unit or Central Station Protected Premises Unit. The VESNet LCD Display (VF8300) with or without the LED ADD-ON Annunciator (VF8203) may also be connected to the VESNet (networked) with the above models
- Proprietary (P) Protected Premises Unit (PPU) provides releasing, non-releasing and VESNet communication on models (VFXX24, VFXX44, VFXX04) containing the Modem-DACT Ethernet, (VFYY04, VFYY05, VFYY08, VFYY09) Integrated Dialer or on models (VFXX21, VFXX41, VFXX01) containing the Media Gateway
- Remote Station (RS) Protected Premises Unit (PPU) provides releasing, non-releasing and eNet communication on models (VFXX24, VFXX44, VFXX04) containing the Modem-DACT Ethernet or on models (VFYY04, VFYY05, VFYY08, VFYY09) containing the integrated Dialer
- Central Station (CS) Protected Premises Unit (PPU) provides releasing, non-releasing and eNet communication on models (VFXX24, VFXX44, VFXX04) containing the Modem-DACT Ethernet or on models (VFYY04, VFYY05, VFYY08, VFYY09) containing the Integrated Dialer
- Proprietary (P) Protected Premises Unit (PPU) provides releasing, non-releasing and eNet communication on models (VFXX24, VFXX44, VFXX04) containing the Modem-DACT Ethernet or on models (VFYY04, VFYY05, VFYY08, VFYY09) containing the Integrated Dialer

"XX" shown in the model numbering above denotes control panel type where "XX" is "09" for eLAN-RS Panels and "08" for Elite-RS Panels.

"YY" shown in the model numbering above denotes control panel type where "YY" is "04" for H-Series eLAN-RS Panels, "05" for A-Series eLAN-RS Panels, "08" for H-Series Elite-RS Panels and "09" for A-Series Elite-RS Panels.

FCC

VES, LLC

This equipment complies with Part 68 of the FCC rule and the requirements adopted by the ACTA. On the Inside cover of this equipment is a label that contains, among other information, a product identifier US:KNTAL00BASA-FACP. If requested, this number must be provided to the telephone company.

The Integrated Dialer is incorporated on the Main Board of the Elite-RS Panel to provide TELCO communication on certain models. Connect permissive data equipment to TELCO line 1 and line 2 of the Elite-RS Panel using independent RJ31X jacks. Reference Section 3, Installation, Connecting Communication, page 25 of this manual for details concerning these connections.

Reference the following:

- ATIS Technical Report No. 5 for connector details
- Facility Interface Code 02LS2
- Service Order Code 9.0Y

A plug and jack used to connect this equipment to the premises wiring and telephone network must comply with the applicable FCC Part 68 rules and requirements adopted by the ACTA. A compliant telephone cord and modular plug must be used. It is designed to be connected to a compatible modular jack that is also compliant. See installation instructions for details.

This product's REN is 0.0. The REN is used to determine the number of devices that may be connected to a telephone line. Excessive RENs on a telephone line may result in the devices not ringing in response to an incoming call. In most but not all areas, the sum of RENs should not exceed five (5.0). To be certain of the number of devices that may be connected to a line, as determined by the total RENs, contact the local telephone company. The REN for this product is part of the product identifier that has the format US:AAAEQ##TXXXX. The digits represented by ## are the REN without a decimal point (e.g., 03 is a REN of 0.3). The REN is separately shown on the door label.

If the terminal equipment Fire Alarm Control Panel causes harm to the telephone network., the telephone company will notify you in advance that temporary discontinuance of service may be required. But if advance notice is not practical. the telephone company will notify the customer as soon as possible. Also, you will be advised of your right to file a complaint with the FCC if you believe it is necessary.

The telephone company may make changes in it's facilities. equipment, operations or procedures that could affect the operation of the equipment. If this happens the telephone company will provide advance notice in order for you to make necessary modifications to maintain uninterrupted service.

If trouble is experienced with this equipment Fire Alarm Control Panel, for repairs or warranty information, please contact VES, LLC 620 Allendale Rd, King of Prussia, PA. 19406 (800)274-9514. If the equipment is causing harm to the telephone network., the telephone company may request that you disconnect the equipment until the problem is resolved.

Reference Section 5, Maintenance and Repair of this manual for details describing standby battery and fuse replacement. No other user serviceable components are contained within this assembly. Contact VES, LLC technical support for diagnostic assistance when necessary. Reference Section 1, Introduction of this manual for details describing technical support, Return Material Authorization (RMA), Warranty Returns, Advanced Replacements and the Product Return Address.

Connection to party line service is subject to state tariffs. Contact the state public utility commission, public service commission or corporation commission for information.

If your home has specially wired alarm equipment connected to the telephone line, ensure the installation of this Fire Alarm Control Panel does not disable your alarm equipment. If you have questions about what will disable alarm equipment, consult your telephone company or a qualified installer.

Reference the Loop Explorer Configuration Manual, AW-000104, Section 4, Programming, page 10 for details describing the programming of this assembly.

NFPA

VES, LLC

Install this product in accordance with NFPA 13, NFPA 72 and NEC 70 and all local codes.

Short Circuit Isolator Modules protect SLC loop devices from single-loop-shorts. SLC loops must be wired with Short Circuit Isolator Modules to comply with NFPA 72, Class A Style 7. SLC loop connections must include closed nipping and conduit nipping to maintain compliance with individual enclosures under NFPA 72, Class A, Style 7 requirements. Closed nipping encloses individual devices on SLC loops and conduit nipping encloses wiring between these individual enclosures. For Class A, Style 6 compliance, the Short Circuit Isolator Modules may be located at strategic locations based on the discretion of the designer or installer.

The NFPA requires that two dedicated and independent TELCO lines feed communication features such as the Integrated Dialer.

Install SLC detectors with spacing as specified in section 90.19 of UL 864, 9th edition where units employing the multiple detector operation shall include guidelines for installing of a minimum of two detectors in each protected space and to reduce the detector installation spacing to 0.7 times the linear spacing in accordance with National Fire Alarm Code, NFPA 72. Also reference 55.3.1 and 55.3.2 of UL 864, 9th edition for these detector spacing requirements.

All field wiring should be installed using fire rated cables according to the NFPA 72. Riser conductors shall be installed in accordance with the survivability from attack by fire requirements in National Fire Alarm Code, NFPA 72, Sections 6.8.6.3, and 6.9.4. Riser conductors shall employ either a 2 hour rated cable system, or meet requirements approved by the AHJ, or installation of the Supervised Output Module using NFPA Style 7 configuration.”

FM Global Technologies LLC (FM APPROVALS)

VES, LLC

Copyright © 2010 by VES, LLC
All rights reserved.



VES is a registered trademark of VES, LLC.
All other product or service names are the property of their respective owners.

VES, LLC
Elite-RS Panel Installation Manual
A-Series

VF3532-00, Revision E01.06

Contents

Section 1

Introduction

- Using This Manual** 3
- Related Documentation** 3
- Document Conventions** 4
 - Part Numbers 4
 - Writing styles 4
- If You Need Help** 4
- Contacting VES Tech Support** 4
 - RMA Returns Required 4
 - Warranty Returns 5
 - Advanced Replacements 5
- Product Return Address** 5

Section 2

Overview

- Points and Addresses** 7
- Zone Capability** 7
- Contact ID Address Restrictions** 8
- Hardware Features** 8
- NAC Outputs** 8
- Panel Controls and Indicators** 9
 - Left-Panel-Indicators 10
 - Right-Panel Controls and indicators 11
 - Lower-Control-Pad 12
 - Settings and Resets 13
- Terminal Connections** 13
- Internal Power Supply** 15

Contents

Section 3

Installation

General Installation Checklist	17
Before You Begin	18
Determining System Current Draw	18
Standby-Battery Capacity	18
Operating Constraints	19
Mounting the Elite-RS Panel	19
Marking the Location	19
Anchoring the Cabinet	20
Feeding Cable	20
Replacing Cabinet Components	20
Connecting Power and Devices	21
Standby-Batteries	21
Before Wiring and Operating	23
AC Wiring	24
Connecting Communication	25
TELCO Communication	25
Connecting Class A Loops	26
NFPA 72, Style 7	27
NFPA 72, Style 6	28
Connecting Class B Loops	29
Installing SLC Devices	29
Detector Spacing	29
Output Modules Controlling Notification Appliances	30
Silencing Notification Appliances	30
NAC Synchronization	30
Connecting NAC Devices	31
Connecting Auxiliary 24 VDC	32
Relay Contacts	32
Installing Municipal Boxes	33
Testing the Installation	34
Confirming a Successful Installation	34
Testing the Panel Lamps	36
Trouble-Silence Test	36
Troubleshooting	38
Test Zones	38
Event Log	41
Loop Data Test	45

Contents

Section 4

Front-Panel Menu

Access Level 2	50
Disablements	50
View Devices	52
Test Zones	52
Set System Time	53
Sensor Maintenance Early Warning	53
Events and Status	53
Access Level 3	54
Front-Panel Controls	56
Alarm Silence	56
Re-Sound Alarm	56
Reset	56
Fire Drill	56
Programmable Function	56

Section 5

Maintenance and Repair

Maintenance	57
Inspecting Batteries	57
Replacing Standby-Batteries	57
Replacing Fuses	59
10 Amp Battery Fuse	59
3 Amp Power-Supply Fuse	60
Removing Cabinet Components	61

Appendix A

Specifications

Electrical	65
Standby and Alarm Current	65
Earth Fault Indication	65
SLC Ratings	65
SLC Cabling	66
Programmable Relay Contacts	66
NAC Outputs	67
RS485 Serial Bus	68
eNET Terminals	68

Contents

24 V OUT	68
Auxiliary 24 VDC	69
AC Line Connection	69
Power Supply	69
Cabling	70
Operating Environment	71
Physical Specifications	71

Appendix B

Equipment List

Elite-RS Panels	73
Loop Devices and Accessories	74
Replacement Parts	76
Notification Appliances	77
Synchronization	77
Configuring NAC Outputs	78
Regulated NAC Outputs	79
Special Application NAC Outputs	79
Maximum Line Impedance	93
Compatible Devices for Auxiliary 24V	93

Appendix C

Calculations

Current-Loading	95
Example of Total Load Current	96
Determining the Standby-Battery Rating	97
Battery Rating Equation	97
Tabulating Data	98
NAC Wiring Length	99
Sample Lmax Calculation	99
Contact ID	107
Zone ID Reporting	107
Point ID Reporting	107

Contents

Appendix D Door Label

Appendix E Operating Instructions

Appendix F Communications Format

SIA 108	
Zone ID Reporting	108
Point ID Reporting	108
Dialing Methodology	108
Dialing Facilities	108
Dialing Sequence	108
Answering Methodology	109
24 Hour Test Report	109
Configure Dialer Settings	109
Phone Numbers	111
Dialing	112
Use Lines	112
Number of rings before Answer	112
Test Code Time	112
Report By Zone or by Point	112
Protocol	112
Account Number	112
Reporting Criteria	112
Suspending Reporting	113

Appendix G Reporting Formats

SIA Point Conversion	115
Contact ID Conversion	126
Event Code Translation	137

Section 1 Introduction

Notice to users, installers, authorities having jurisdiction, and other involved parties.

This product incorporates field-programmable software. In order for the product to comply with the requirements in the Standard for Control Units and Accessories for Fire Alarm Systems, UL 864 9th Edition, certain programming features or options must be limited to specific values or not used at all as indicated below.

Program Feature or Option	Permitted in UL 864 ? (Y / N)	Possible Settings	Settings Permitted In UL 864
AC Fail Delay	Yes	0 - 24 hours	1 - 3 hours
Alarm Verification	Yes	5 - 60 seconds	60 second
Disable Buzzer	Yes	Enable / Disable	Enable
Disable Ground Trouble	Yes	Enable / Disable	Enable
Set Buzzer Silence Access Level	Yes	1 or 2	2
NAC Output Delay Stage 1	No	0 - 5 minutes	0 minutes
NAC Output Delay Stage 2	No	0 - 5 minutes	0 minutes
Photoelectric Smoke Sensor Delay	Yes	0 -120 seconds	0 seconds
Ionization Smoke Sensor Delay	Yes	0 -120 seconds	0 seconds
Duct Detector	Yes	0 -120 seconds	0 seconds
Duct Detector with Relay	Yes	0 -120 seconds, 0 - 5 seconds	0 seconds
Contact Module Delay (All models)	Yes	0 -120 seconds	0 seconds
Conventional Zone Module Delay	Yes	0 -120 seconds	0 seconds
Dual Relay Module Delay	Yes	0 - 5 seconds	0 seconds
Supervised Output Module Delay	Yes	0 - 5 seconds	0 seconds

Reference Appendix B, "Equipment List" for the specific models described in this table.

This manual describes 1 and 2 loop models of the VES Elite-RS A-Series Panel. All models of the Elite-RS A-Series Panel support Apollo loop protocol.

One loop models include the No Communication VF0850, the Non-Expandable, No Communication VF0870, the Media Gateway VF0851, the Non-Expandable, Media Gateway VF0871, the Network Interface Card (NIC) VF0852, the Network Interface Card (NIC) VF0872, the Modem-DACT Ethernet VF0854-00, the Non-Expandable, Modem-DACT Ethernet VF0874-00, the eNet Interface VF0855, the Integrated Dialer VF0856, the Non-Expandable, Integrated Dialer VF0876 and the eNet Interface & Integrated Dialer VF0857.

Two loop models include the No Communication with Loop Expansion Module VF0860, the Media Gateway with Loop Expansion Module VF0861, the NIC with Loop Expansion Module VF0862, the eNet Interface with the Loop Expansion Module VF0865, the Integrated Dialer with the Loop Expansion Module VF0866 and the eNet Interface & Integrated Dialer with the Loop Expansion Module VF0867.

This section describes:

- Using This Manual
- Related Documentation
- Document Conventions
- If You Need Help
- Contacting VES For Repair

The figure below illustrates the Elite-RS Panel:

Figure 1-1
Elite-RS Panel



Using This Manual

The following sections provide instructions for installing, testing and troubleshooting the Elite-RS Panel:

- Section 1 Introduction** provides document conventions, the technical help-line, repair and return information.
- Section 2 Overview** provides a summary features of the Elite-RS Panel.
- Section 3 Installation** describes how to setup, install and test the Elite-RS Panel.
- Section 4 Front-Panel Menu** describes how to operate the Elite-RS Panel from its front-panel.
- Section 5 Maintenance and Repair** describes how to maintain and repair the Elite-RS Panel.
- Appendix A Specifications** provides characteristics of the Elite-RS Panel.
- Appendix B Equipment List** provides model numbers for VES Elite-RS Panels, loop devices, accessories, replacement parts and compatible Notification Appliances.
- Appendix C Calculations** provides calculations for determining load capacity, battery rating, and wiring length of the Elite-RS Panel.
- Appendix D Front Door Label** is a copy of the Elite-RS Panel front door label.
- Appendix E Operating Instructions** provides an overview of Elite-RS Panel status and control instructions.
- Appendix F Communication Formats** describes settings and characteristics of the embedded dialer.
- Appendix G Reporting Formats** contains tables for SIA point conversion, Contact ID conversion and Event Code translation.

Related Documentation

The following documents shall be used to provide additional information for installing the Elite-RS Panel:

- 16 Channel I/O Interface Installation Manual, VF3512-00, E01.XX
- eView Installation Manual, VF3510-00, E01.XX
- eMatrix Installation Manual, VF3513-00, E01.XX
- eNet Installation Manual, VF3511-00, E01.XX

Document Conventions

This document contains conventions for part numbers and writing style.

Part Numbers

Part numbers are provided in Section 1, Appendix B and Appendix D of this manual. Refer to Appendix D, Door Label for a diagram summary of this manual. Refer to Appendix B, Equipment List for a complete list of part numbers required for completing this installation.

Writing styles

Before you begin using the Elite-RS Panel, familiarize yourself with the stylistic conventions used in this manual:

Italic type Denotes a displayed variable, a variable that you must type, or is used for emphasis.

Courier font Indicates text displayed on a computer screen.

If You Need Help

If you need technical support contact VES at (800) 274 - 9514 or email techsupport@ves-network.com. VES technical support is available Monday through Friday, 9:00 AM to 6:00 PM, Eastern Standard Time.

Contacting VES Tech Support

On-site technicians familiar with the product issue should contact VES Tech Support and include the:

- Product part number
- Purchase order or VES order number
- Product serial number
- Current function of the product
- Expected function of the product
- Installation of the product

RMA Returns Required

A Return Material Authorization (RMA) must be assigned to all products returning to VES. VES Tech Support will assign an RMA to a returning product after recording information collected from the on-site technician. VES cannot not accept product-returns that do not include an accompanying RMA number.

An RMA number is assigned when:

- A product issue is acknowledged by a VES Tech Support representative
- A product was damaged during shipping
- An incorrect product was shipped
- An order was placed using an incorrect part number *
- An order was placed using an incorrect part quantity *
- An order is no longer required *

* Restocking fees may apply.

Warranty Returns

VES Tech Support can replace a defective product when the original purchase is within the warranty period defined in the sales contract. Check your sales-contract for more information or contact your VES sales representative about the warranty period described in your sales-contract.

Warranty products that have been placed in service will be repaired or replaced by VES.

Warranty products that have *not* been placed in service will be returned to VES stock and an equivalent credit will be provided to the contractor.

Advanced Replacements

Suspect-products that fail to operate in the field can be replaced quickly using the advanced replacement process. The advanced replacement process is available to all contractors who maintain an acceptable line of credit with VES.

Initiate the advanced replacement process by requesting an RMA number from a VES Tech Support representative. Advanced replacements can be shipped to your location when the suspect-product is covered under warranty and when a replacement product is in stock. All advanced replacement products are shipped UPS ground.

Expedited Replacements

Advanced replacements can be expedited at the request of the contractor. Shipping costs associated with this process are the responsibility of the contractor.

Returning Products

Products returning to VES using the advanced replacement process must be received 30 days from the RMA issue-date. Contractors can be billed for returning products received following this 30 day period.

Product Testing

Products returned to VES are tested to confirm operating failures experienced in the field.

If the suspect-product is found to be functional, contractors must absorb expenses for:

- Shipping of the advanced replacement product
- Return-shipping of the original product
- Cost of the advanced replacement product

Product Return Address

Prominently display the RMA number on all packages sent to VES for return.

Ship all return products to:

Attention: RMA # _____

VES, LLC

620 Allendale Road, Suite 175

King of Prussia, PA. 19406

This page intentionally left blank.

Section 2 Overview

Models of the A-Series Elite-RS Panel support SLC devices using Apollo protocol. The standard model of the Elite-RS Panel contains one SLC loop and may be expanded to include a second SLC Loop. The Elite-RS Panel supports the networking flexibility of either the eNet or the VESNet. In either networking scenario signals for all network nodes are transmitted through a single dialer.

VESNet networking is a proprietary and secure protocol for linking communication between control panels. The VESNet uses embedded communication-cards to provide networking. Obtain the VESNet connection at jack J3 of these communication-cards.

The eNet provides a secure networking architecture, between control panels. Up to 64 Elite-RS Panels can be connected together on the eNet.

In either networking scenario; Elite-RS Panels also supports Remote LCD Annunciators and Graphic Annunciators. Annunciators (repeater panels) and graphical annunciators are fully supported in multiple or single quantities through standard communication bus included with the panel.

The Elite-RS Panel can be equipped with an industry standard digital communicator capable of transmitting both SIA and Contact ID formats. Configurations can be performed through VES Loop Explorer, eSP Discovery or through the use of the front-panel soft-keys.

Configuring with the front-panel soft-keys of the Elite-RS provides limited functionality. VES recommends configuring with Loop Explorer or eSP Discovery for a complete range of programming features.

VESNet networking and panel programming are performed through eSP Discovery.

The eSP Discovery application is a web based configuration utility for control panels that provides programming for communication, SLC devices, notification appliances and initiation devices. Configure parameters for these attributes on the web and then download them to the Elite-RS Panel through the telephone connection to the dialer or locally through Transfer Agent.

The Loop Explorer application is a configuration utility for control panels that provides programming for communication, SLC devices, notification appliances and initiation devices. Configure parameters for these attributes remotely or on-site and then download them to the Elite-RS Panel through the serial port of your laptop or through a telephone connection to the dialer.

Points and Addresses

Points and addresses are fundamental to the operation of Elite-RS monitoring and reporting. Devices are identified as points when connected to the Elite-RS Panel. Each Elite-RS Panel supports a maximum of 126 points per loop plus subpoints on any module or 252 points per loop when utilizing subpoints. The 1 and 2 loop Elite-RS Panel supports a maximum of 800 devices per panel.

All Elite-RS Panels support a point and subpoint maximum of 800 addresses per panel.

Zone Capability

Zones are groups containing combinations of control panel input, output and addressable loop devices. The Elite-RS Panel supports 500 zones across the network.

Contact ID Address Restrictions

Address reporting restrictions affect all models of the Elite-RS Panel when using the Contact ID format. The Contact ID format limits reporting to addresses of 99 and above. The format employs three digits in the protocol. The first digit is reserved for the loop number and the remaining digits are reserved for addressing.

Allocation of the first digit is described below:

First digit	Description of numeric value
0	Zero I/O connections on the control panel
1	SLC loop 1
2	SLC loop 2

The Contact ID format can be used for devices as long as the device address is 99 or below. Using contact ID protocol with point reporting will result in truncation of data for points above 99.

FACP reporting can be changed from point reporting to zone reporting when the limit of 99 addresses per loop cannot be avoided. Zone reporting can be used to resolve address assignments in excess of 99 but doing so reduces overall reporting granularity.

Models of the Elite-RS Panel can be programmed for the SIA or Contact ID digital communication format. The SIA and Contact ID format provide status monitoring and reporting to industry-standard receivers at the monitoring-center.

Both of these digital communication formats provide a range of addressing for device-points and sub-points on the Elite-RS Panel. The SIA format allows full reporting from all device-points and sub-points. The Contact ID format provides a limited range of reporting from device-points.

Reference Appendix B, "Equipment List" for all models affected by restrictions of the Contact ID format.

Hardware Features

The figure below illustrates hardware features of the Elite-RS Panel:

Figure 2-1
Hardware Features\

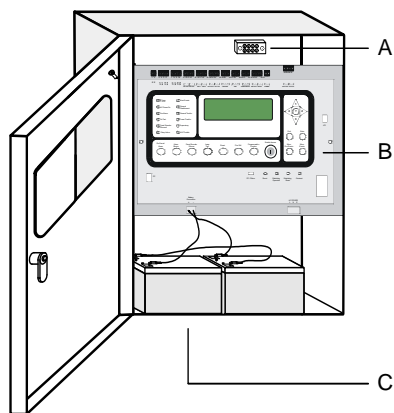

Key	Description
A	Grounding Block
B	Front-Panel
C	Batteries

NAC Outputs

NAC outputs of the Elite-RS Panel are programmable and can be operated in regulated or special application mode.

Reference Appendix A, Specifications for constraints and operating levels of these NAC output modes.

Panel Controls and Indicators

The figure below illustrates controls and indicators of the Elite-RS Panel:

Figure 2-2
Controls and Indicators

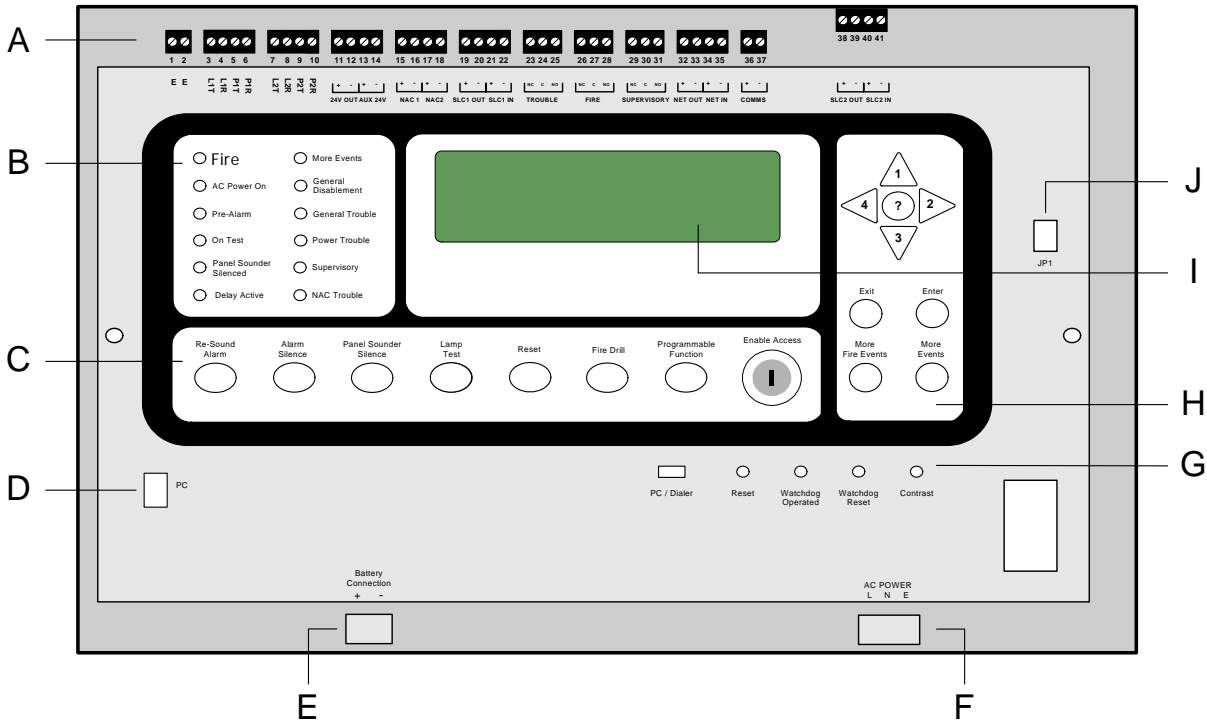

Key	Description	Key	Description
A	Terminal connections	F	AC power connections
B	Left-panel-indicators	G	Settings and controls
C	Lower-control-pad	H	Right-panel-controls and indicators
D	PC connection	I	LCD Display
E	Battery connection	J	JP1 connection

Left-Panel-Indicators

The figure below illustrates left-panel-indicators:

Figure 2-3
Left-Panel-Indicators

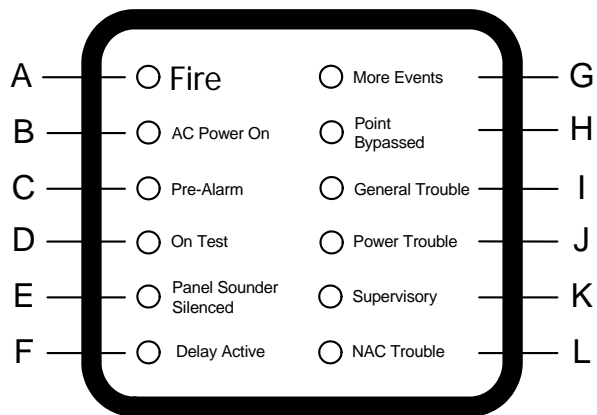

Key	LED Indicator	Color
A	Fire, NAC Output State - Flashing = NACs Activated - ON Continuous = NACs silenced - OFF = Panel and NACs Reset	Red
B	AC Power On	Green
C	Pre Alarm	Yellow
D	On Test	Yellow
E	Panel Sounder Silence	Yellow
F	Delay Active	Yellow
G	More Events	Yellow
H	Point Bypassed	Yellow
I	General Trouble	Yellow
J	Power Trouble	Yellow
K	Supervisory	Yellow
L	NAC Trouble	Yellow

Right-Panel Controls and indicators

The figure below illustrates right-panel controls and indicators:

Figure 2-4
Right-Panel-Indicators

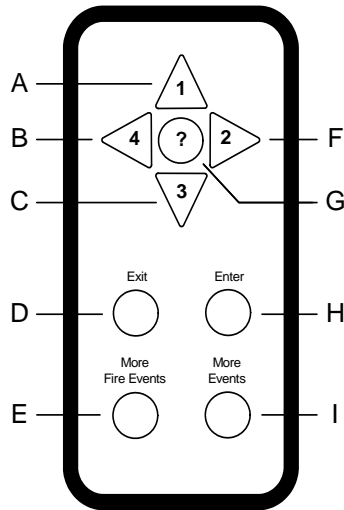

Key	Name	Description
A	Keypad number one	Navigates menu selections up.
B	Keypad number four	Navigates menu selections to the left.
C	Keypad number three	Navigates menu selections down.
D	Exit	Cancels the current menu selection.
E	More Fire Events	Displays the number of alarms present on the Elite-RS Panel and overrides the display provided by menu navigation.
F	Keypad number two	Navigates menu selections to the right.
G	Keypad question mark	Provides a “help screen” for the current menu display and also displays status. For example, recommendations are displayed during alarm or fault conditions. If a menu function is accessed then help relating to that function will be displayed.
H	Enter	Enables the menu selection.
I	More Events	Displays the number of events present and overrides menu navigation. Provides event status for Fire, Pre-Alarm, Trouble, Disablements and Other.

Lower-Control-Pad

The figure below illustrates the lower-control-pad:

Figure 2-5
Lower-Control-Pad

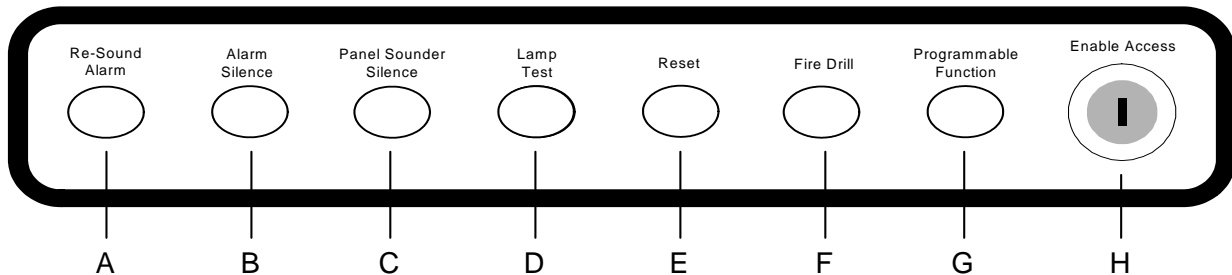

Key	Name	Description
A	Re-Sound Alarm	Re-sounds the alarm when sounders are silenced using the Alarm Silence button.
B	Alarm Silence	Silences NACs connected to the Elite-RS Panel after receiving authorization through Access Level 2.
C	Panel Sounder Silence	Silences the internal buzzer of the Elite-RS Panel. No other sounder outputs are affected by this operation.
D	Lamp Test	Tests front-panel indicators and the internal buzzer by illuminating all LEDs while darkening the front-panel display and sounding the buzzer.
E	Reset	Resets latching inputs such as fire and pre-alarm events after receiving authorization through Access Level 2. Fault events are non-latching inputs and cannot be cleared by the Reset button. Non-latching inputs are cleared when faults are cleared.
F	Fire Drill	Provides a fire drill for the Elite-RS Panel after receiving authorization through Access Level 2. During the drill: <ul style="list-style-type: none"> • The “On Test” LED illuminates continuously • The “Fire” LED blinks • The internal buzzer sounds intermittently • The display provides the message, “FIRE DRILL:FIRE DRILL ZONE 00” To stop the fire drill: <ol style="list-style-type: none"> 1 Press 4 to display the “SET ACCESS LEVEL 2 MENU”. 2 Provide Access Level 2 authorization. 3 Press Reset or Fire Drill on the lower-control-pad.
G	Programmable Function	Activates inputs, outputs or actions defined in the configuration by the installer.
H	Enable Access	This feature places the menu of the Elite-RS in ACCESS LEVEL 2. Insert the key in the lock and turn it to the right to obtain ACCESS LEVEL 2.

Settings and Resets

The figure below illustrates settings and resets of the Elite-RS:

Figure 2-6
Settings and Resets

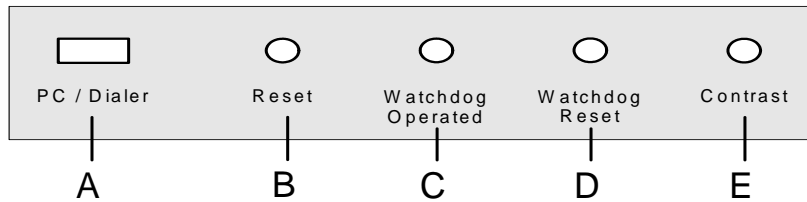

Key	Name	Description
A	PC / Dialer	Two-position slide switch for setting PC or Dialer operation. Place this switch in the PC position when downloading Loop Explorer configurations and in the Dialer position when using utilizing TELCO communication for the Integrated Dialer. Return the PC/Dialer switch to the Dialer position following downloads to provide continued TELCO communication. The Integrated Dialer is an optional feature and may not be provided on certain models.
B	Reset	Restores operation by restarting processors in the Elite-RS Panel. Press Reset after a firmware upgrade to re-initialize processors in the panel.
C	Watchdog Operated	Illuminates when the processor of the Elite-RS Panel stops running or re-boots.
D	Watchdog Reset	Turns off the Watchdog Operated LED by resetting it.
E	Contrast	Trim pot adjustment for increasing or decreasing the contrast of the LCD.

Terminal Connections

The figure below illustrates Terminal connections of the Elite-RS Panel:

Figure 2-7
Terminal Connections

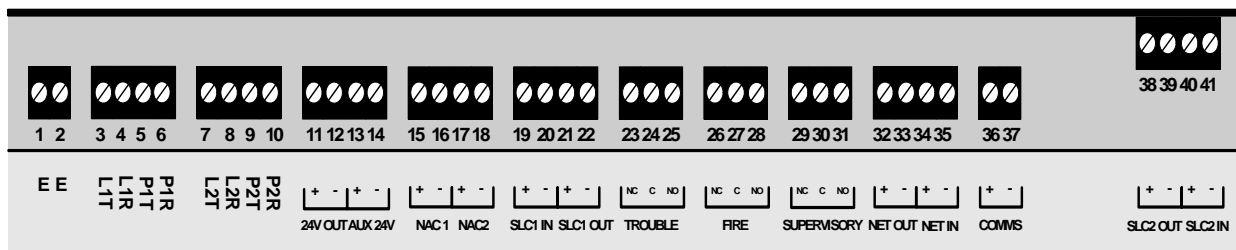

The table below describes Terminal designations of the Elite-RS Panel:

Designation	Terminal	Description
E, E	1 and 2	Earth ground
L1T	3	TELCO Line 1 tip
L1R	4	TELCO Line 1 ring
P1T	5	TELCO Phone line 1 tip. This terminal drops TELCO connection during alarm conditions to allow communication on L1T.
P1R	6	TELCO Phone line 1 ring. This terminal drops TELCO connection during alarm conditions to allow communication on L1R.
L2T	7	TELCO Line 2 tip
L2R	8	TELCO Line 2 ring
P2T	9	TELCO Phone line 2 tip. This terminal drops TELCO connection during alarm conditions to allow communication on L2T.
P2R	10	TELCO Phone line 2 ring. This terminal drops TELCO connection during alarm conditions to allow communication on L2R.
24V OUT	11 and 12	Terminal connections for the 24 volt output
AUX 24V	13 and 14	Terminal connections for the auxiliary 24 volt output
NAC1	15 and 16	Terminal connections for the NAC 1 circuit.
NAC2	17 and 18	Terminal connections for the NAC 2 circuit.
SLC1 IN	19 and 20	Terminal connections for the "IN" of SLC loop 1.
SLC1 OUT	21 and 22	Terminal connections for the "OUT" of SLC loop 1.
TROUBLE	23, 24 and 25	Trouble relay contacts
FIRE	26, 27 and 28	Fire relay contacts
SUPERVISORY	29, 30 and 31	Supervisory relay contacts
NET OUT	32 and 33	Terminals connections for the "OUT" of the eNET network
NET IN	34 and 35	Terminals connections for the "IN" of the eNET network
COMMS	36 and 37	Terminal connections for RS485 serial communication
SLC2 OUT	38 and 39	Terminal connections for the "OUT" of SLC loop 2.
SLC2 IN	40 and 41	Terminal connections for the "IN" of SLC loop 2.

Internal Power Supply

The internal power supply of the Elite-RS Panels meets UL 864, 9th edition and provides a 5.25 Amp, off-line switch-mode power-source for operating FACP functions as well as charging the standby batteries.

The 5.25 Amp power supply can operate at 120 or 240 VAC. A jumper connection is provided on the power supply to switch between these operating voltages. Connecting the jumper provides 120 VAC operation and removing it provides 240 VAC operation.

Reference Appendix C, Calculations to determine load current limitations of the 5.25 Amp power supply

Features of the power supply include:

Battery-backup	Provides battery power to the load when the AC input of the power supply falls below the rated level. The voltage at the load remains within the specified range during these switching-transitions.
Battery-boost	Boosts voltage when the battery voltage drops due to a low-battery condition.
Short-circuit protection	Provides a shut down on the load side of the power supply when the load-current exceeds the maximum level.
Automatic-retry	Restores output to the load when operating conditions return to nominal levels. This feature restores voltage levels at the load following conditions such as over-current and battery depletion.
Status	The AC input to the power supply is supervised by the Elite-RS Panel. The control panel provides an LED status display for normal and fault conditions. Normal conditions occur when the power supply is operating in an acceptable range. Fault conditions occur when the power supply is not operating in an acceptable range.

This page intentionally left blank.

Section 3 Installation

This section provides instructions for connecting cables, mounting and testing the Elite-RS Panel for installation.

General Installation Checklist

To complete the installation:

- 1 Create a plan of the fire alarm system and checklist for installing the Elite-RS Panel.
- 2 Determine the current draw of the fire alarm system.
- 3 Determine the battery capacity of the Elite-RS Panel.
- 4 Remove the Elite-RS Panel from its packaging and check its contents.
- 5 Remove the standby-batteries from the base of the cabinet.
- 6 Mark the location for anchoring the cabinet to the premises-wall.

CAUTION!



Maintain extreme care when anchoring the cabinet and its contents to the premises wall. Electronic components within the Elite-RS Panel are vulnerable to physical damage from severe shock and vibration. Remove the cabinet-door and front-panel from the cabinet when installations cannot guarantee vigilant care during the wall-anchoring process.

- 7 Anchor the cabinet of the Elite-RS to the premises-wall.
- 8 Thread cabling into the cabinet and secure it.
- 9 Place standby-batteries in the base of the empty-cabinet.
- 10 Attach the cabinet-door and the front-panel to the cabinet.
- 11 Connect the standby-batteries to the terminal-connection on the front-panel.
- 12 Connect all cabling.
- 13 Apply power to the Elite-RS Panel from the AC source.
- 14 Configure the Elite-RS Panel.
- 15 Test the Elite-RS Panel installation.

Before You Begin

Before you begin the installation, take a few minutes to review the installation information, gather the required items, and complete the tasks listed below to make the installation as quick and easy as possible.

- 1 Create a plan and checklist before beginning the installation process. Planning can reduce the number of problems that can occur during installation.
- 2 Select a mounting site for the Elite-RS Panel that is suitable for its operating environment. The site chosen for mounting the Elite-RS Panel should be clean and dry and not subject to shock or vibration. Ensure that the Elite-RS Panel environment is free from wire ends, knockout discs and any other debris.

CAUTION!



The Elite-RS Panel installation must be performed by qualified personnel familiar with electronic components. Electronic components within the Elite-RS Panel are vulnerable to damage from electrostatic discharge. Ground straps must be worn by installers before handling Elite-RS Panel circuit boards to prevent damage from electrostatic discharge.

- 3 Acquire the following items that are not included with the Elite-RS Panel, but may be required for the installation:

Item	Quantity	Description
Dual phone Cable	1	The dual phone cable connects to an RJ31X jack assigned to line 1 and to an RJ31X jack assigned to line 2. <i>Reference Figure 3-16, Integrated Dialer Connections for more information on dual phone cable wiring.</i>
Mounting Hardware	1	The mounting hardware that secures the Elite-RS Panel to the premises-wall is not provided in the Elite-RS Panel packaging.
Ground Strap	1	A ground strap is required for handling Elite-RS Panel circuit boards. <i>The ground strap is not provided in packaging of the Elite-RS Panel.</i>

CAUTION!



Disconnect power before removing Elite-RS Panel circuit boards. Never insert or remove circuit boards while the Elite-RS Panel power is on. The Elite-RS Panel can be damaged if its circuit boards are removed while under power.

Determining System Current Draw

Determine the current draw of the fire alarm system for alarm and standby conditions. Use these maximum current values to obtain the battery capacity of the fire alarm system as well as to confirm the operating constraints of the system.

Standby-Battery Capacity

Perform the installation only after calculations have been completed for a suitable battery size.

Battery standby-hours are dependant on battery capacity and load of the FACP system. *Reference Appendix C, Calculations to determine the standby-battery capacity of the system.*

Operating Constraints

Installation of the FACP must include the operating constraints of the system to maintain continuous signal monitoring and reporting. Operating constraints are based on the current-driving capability of the Elite-RS outputs and the external loading caused by devices and cabling.

External loads connected to the Elite-RS outputs must be chosen within the driving limits of each output. The loading placed on these outputs can be caused by individual or multiple combinations of signaling line circuits, notification appliances and initiating devices. Cabling is also an external loading property on the Elite-RS outputs. Select cabling size and length based on the type of circuit connected to the output of the Elite-RS Panel.

Reference Appendix A, Specifications and Appendix C, Calculations to determine specific operating constraints for devices and cabling connected to the Elite-RS Panel.

Mounting the Elite-RS Panel

Select a mounting location that provides adequate room for opening the door of the Elite-RS Panel. Provide a minimum of 1” clearance beyond the door-edge when anchoring the Elite-RS Panel.

Figure 3-1
Door Clearance Recommendation

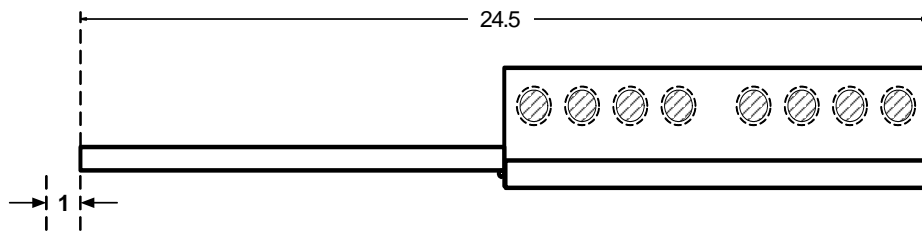

Marking the Location

Mark hole locations on the premises-wall for mounting the Elite-RS Panel.

Figure 3-2
Hole Marking Requirements

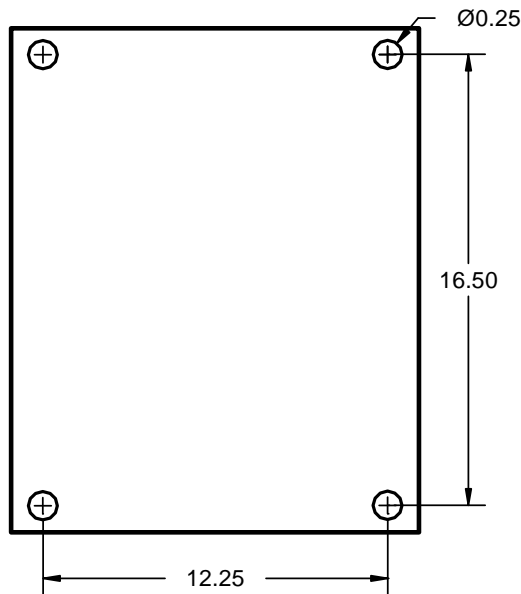

Anchoring the Cabinet

Drill holes in the premises-wall to anchor the empty Elite-RS cabinet using mounting-hardware to secure it.

Feeding Cable

Remove knockout tabs from the cabinet to feed cabling for AC power, 24 VDC, TELCO, eNet, VESNet, addressable devices, initiation devices and notification appliances. Dress AC cabling as far away as possible from TELCO, and device communication.

Separate high and low voltage wiring in the enclosure with a minimum gap of 0.25". Reference UL 864 12.3.1.

To feed cabling into the cabinet:

- 1 Remove the top-left and top-right knockout tabs from the cabinet.

Figure 3-9
Removing Knockout Tabs

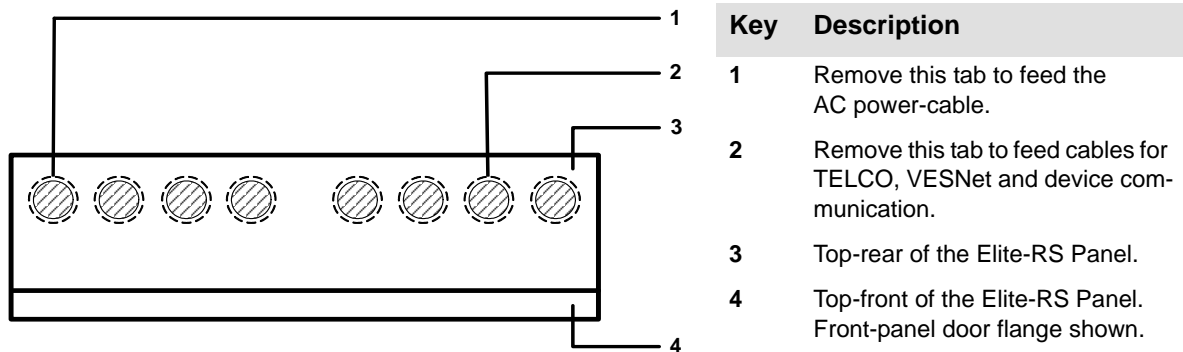

CAUTION!

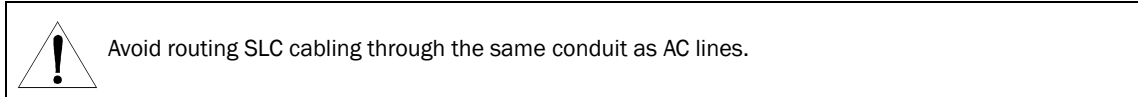

- 2 Feed the AC power-cable into the top-left-hole provided from the knockout-tab.
- 3 Feed cables for 24 VDC, TELCO, VESNet, addressable devices, initiation devices and notification appliances into the top-right-hole. Remove additional knockout-holes directly adjacent to this knockout-hole, to provide more cabling space as required.

Replacing Cabinet Components

Replace cabinet components of the Elite-RS to prepare for wiring the terminal-connector for AC power.

To prepare for wiring the terminal-connector for AC power:

- 1 Remove debris from the base of the cabinet that may have accumulated during the anchoring process.
- 2 Replace the front-panel on the cabinet-hinges and insert the hinge-pins to secure it.
- 3 Replace the cabinet-door on the cabinet-hinges and insert the hinge-pins to secure it.

Connecting Power and Devices

This section describes connecting power and devices to the Elite-RS panel.

Standby-Batteries

Perform the installation only after calculations have been completed for selecting a suitable battery size. Battery standby-hours are dependant on battery capacity and loading of the FACP system.

*Reference Section 5, “Maintenance and Repair for replacement requirements for the standby-batteries”.
FM Approval requires secondary power to provide a minimum of 90 hours of standby operation followed by a minimum of 10 minutes of alarm operation.*

The Elite-RS Panel accepts battery sizes up to 18AH. Batteries larger than 18AH may be mounted remotely in a UL-listed VES Battery Cabinet. Batteries smaller than 18 AH do not require special cabinet-mounting considerations. Reference Appendix B, “Equipment List” for UL-listed battery cabinets. The power supply can charge batteries up to 50 AH. Install two 12 VDC, 50 AH batteries in a battery cabinet listed for use by UL 864.

Batteries that are 18AH require special mounting considerations when installing them in the base of the cabinet. Flanges located at the lower and middle-section of the cabinet prevent battery mounting directly at the cabinet-base. Lift the standby-batteries into the cabinet above the flanges and then lower them onto the cabinet-base.

To install standby-batteries:

- 1 Place two 12 VDC batteries in the base of the Elite-RS cabinet that conform to the battery capacity values determined from Appendix C, Calculations.
- 2 Wire the batteries in series using kit VF1514-00.
- 3 Remove the battery-terminal-connector from the terminal-socket on the Elite-RS Panel.
- 4 Orient the terminal-connector with the screw-heads facing up.

Figure 3-10
Orienting the AC Terminal-Connector

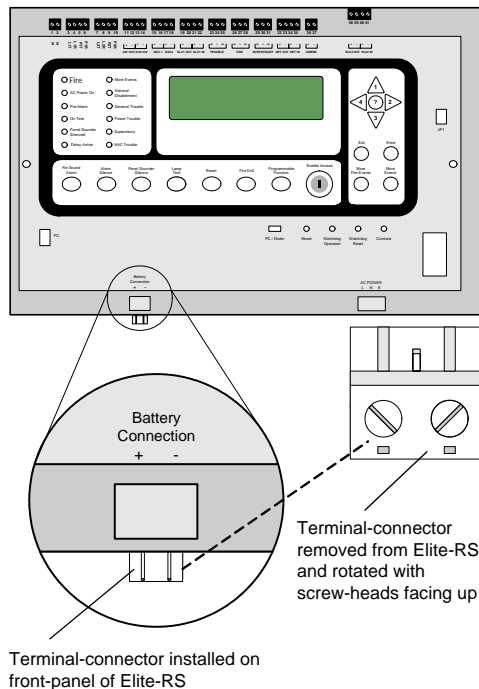

- 5 Connect wires from the standby-batteries to the battery-terminal-connector.

Figure 3-11
Wiring the Terminal Connector

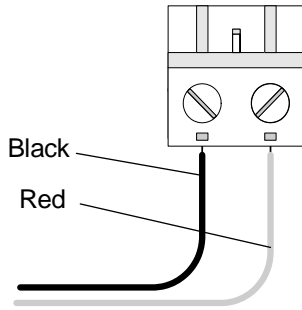

Terminal-connector above shown with screw-heads facing up.

- 6 Insert the terminal-connector in the Battery Connection port on the front-panel of the Elite-RS.

Figure 3-12
Installing the Standby-Batteries

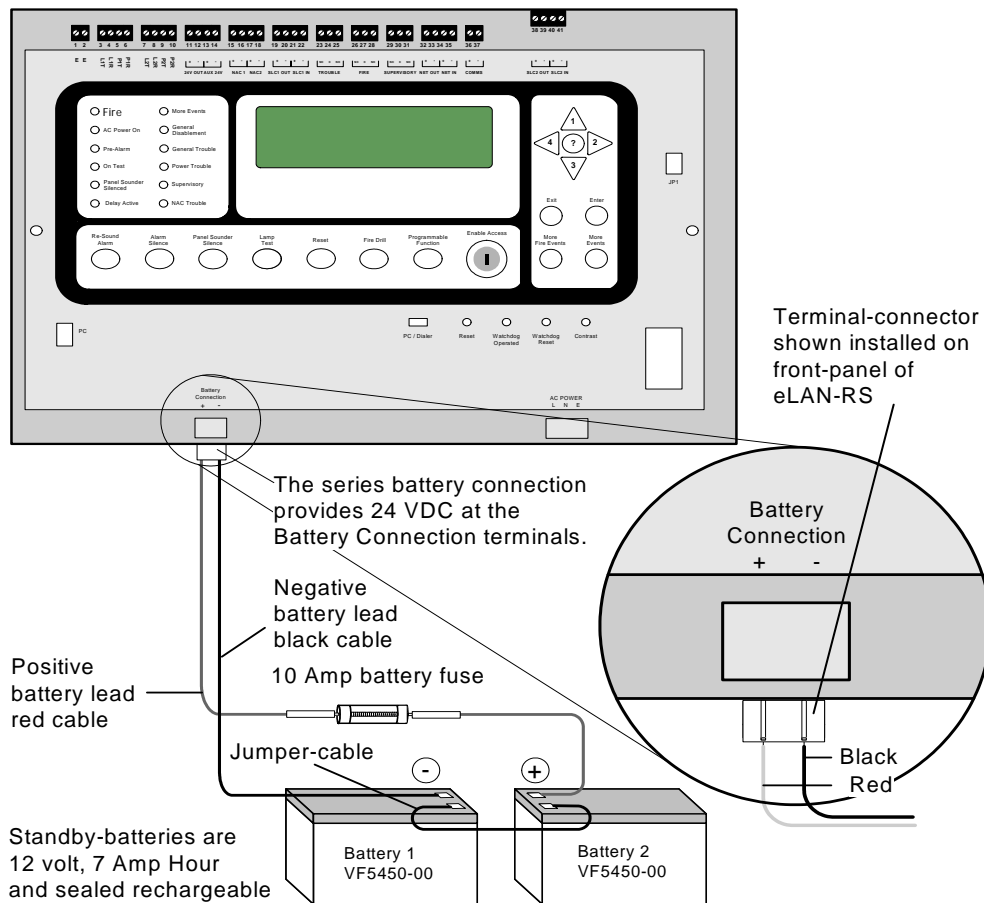

Battery Kit, VF1514-00 contains battery leads, jumper and fuse assembly VF1548-00. Fuse assembly VF1548-00 contains 32 V @ 10 A fuse with red cabling.

Before Wiring and Operating

The 5.25 Amp power supply of the Elite-RS Panel provides settings for voltage inputs of 120 VAC or 240 VAC. Check these input settings prior to wiring and operating the control panel. Make certain that the power supply is set for 240 VAC before operating at 240 VAC. Failure to make this check will cause permanent damage to the power supply when the input setting is 120 VAC and applied voltage is 240 VAC.

Remove jumper J1 from the circuit-board of the power supply to provide 240 VAC operation. Connect jumper J1 to the circuit-board to provide 120 VAC operation.

WARNING!



Remove jumper J1 before operating the Elite-RS Panel at 240 VAC. Failure to remove jumper J1 before 240 VAC operation will cause severe and permanent damage to Elite-RS components.

The figure below illustrates the location of jumper J1 on the circuit-board of the Elite-RS Panel:

Figure 3-13
Circuit-Board Jumper J1

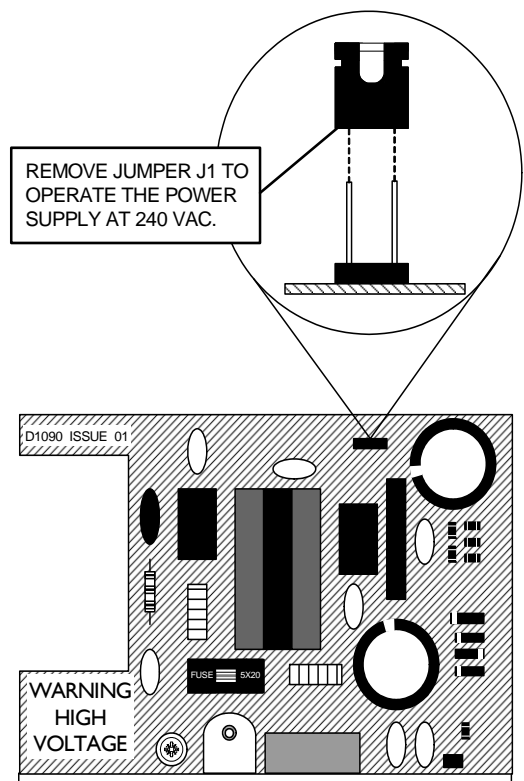

AC Wiring

Connect cabling from the power source to the terminal-connector for AC Power. The AC Power terminal-connector is located on the bottom-right of the Elite-RS Panel.

Protect source connections to the AC Power terminal-connector with a 20 Amp fuse. Complete cabling to the AC Power terminal-connector using three insulated wires that are black, white and green.

Reference Appendix A, Specifications for the wire-gage requirements of these connections.

To wire the terminal-connector:

- 1 Remove the terminal-connector from the AC Power connection of the Elite-RS.
- 2 Orient the terminal-connector with the screw-heads facing up.

Figure 3-14
Orienting the AC Terminal-Connector

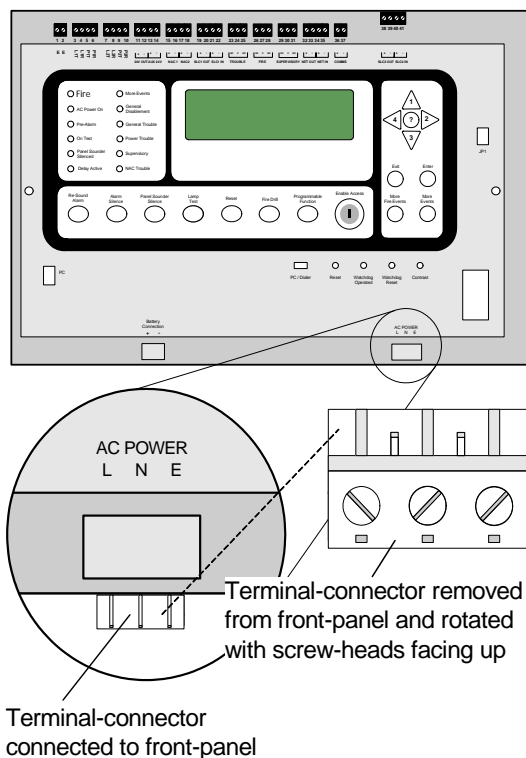

- 3 Cut 3 feet of black wire and strip 1/4" of insulation from one end.
- 4 Insert the stripped end of the black-wire in the left-side of the connector.
- 5 Tighten the left-screw so that the black-wire is secure in the terminal-connector.
- 6 Cut 3 feet of white-wire and strip 1/4" of insulation from one end.
- 7 Insert the stripped end of the white-wire in the right-side of the connector.
- 8 Tighten the right-screw so that the white-wire is secure in the terminal-connector.
- 9 Cut 3 feet of green-wire and strip 1/4" of insulation from one end.

- 10 Connect the ground wire to the cabinet ground-stud.

Figure 3-15
Wiring the terminal-Connector

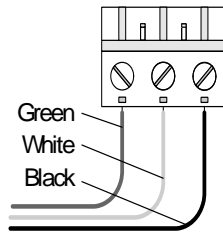

The terminal-connector is shown rotated with screw-heads facing up and is shipped pre-wired from the factory.

To complete the wiring process for AC power:

- 1 Insert the battery terminal-connector in the Battery Connection socket on the front-panel of the Elite-RS.
- 2 Insert the AC terminal-connector in the AC Power socket on the front-panel of the Elite-RS.
- 3 Connect cabling for serial data, TELCO and DC power.
- 4 Connect initiating devices, notification appliances and signalling circuits.
- 5 Test the installation following these connections. *Reference "Testing the Installation" in this section.*

Connecting Communication

The Elite-RS Panel provides options for TELCO, eNet and VESNet communication.

Reference the eNet Interface Installation Manual, VF3511-00 for eNet connections and features. Reference NIC Installation Manual VF1629-00 and Media Gateway Installation Manual, VF1627-00 for VESNet connections and features.

The NFPA requires that two dedicated and independent TELCO lines feed communication features such as the Integrated Dialer.

TELCO Communication

The Integrated Dialer is incorporated on the Main Board of the Elite-RS Panel and is provided on certain models to provide TELCO communication.

Reference Appendix B, Equipment List for Elite-RS Panel models supporting the Integrated Dialer.

Reference Appendix A, Specifications for wire gages acceptable for these terminal block connections.

Reference Figure 3-16 on the following page for these connections.

Connections For TELCO Line 1

To complete connections for TELCO line 1 connections:

- 1 Connect the tip-wire of the phone-line to terminal P1T.
- 2 Connect the ring-wire of the phone-line to terminal P1R.
- 3 Connect the tip-wire of the Elite-RS-line to terminal L1T.
- 4 Connect the ring-wire of the Elite-RS-line to terminal L1R.

Connections For TELCO 2

To complete connections for TELCO line 2 connections, duplicate the TELCO wiring of line 1 for line 2.

The figure below illustrates connections to the Integrated Dialer for TELCO line 1 and line 2:

Figure 3-16
Integrated Dialer Connections

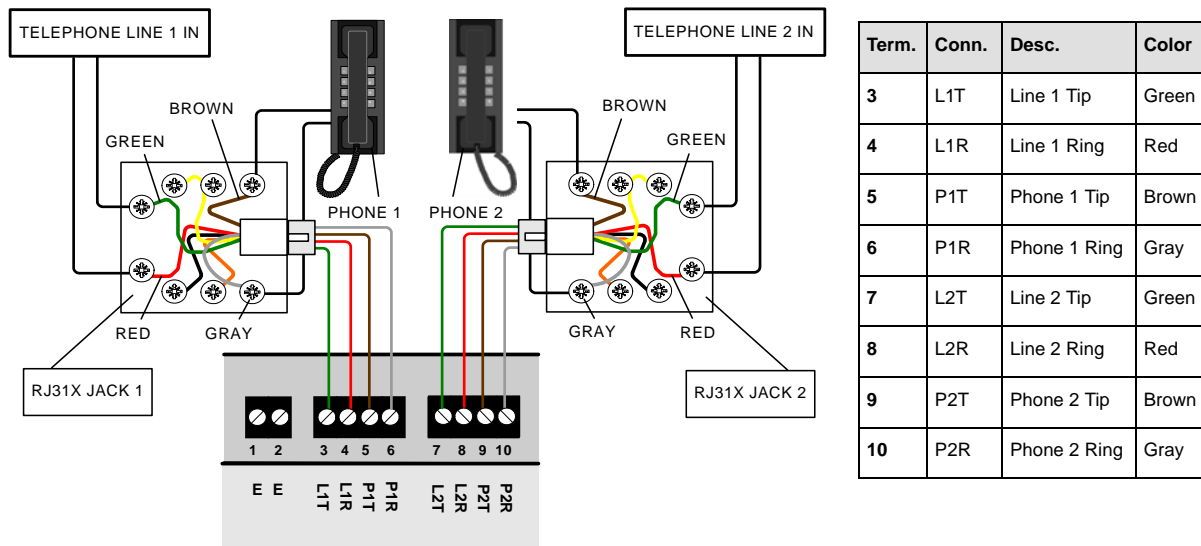

Connecting Class A Loops

The Elite-RS Panel provides Class A loop connections at SLC 1 terminals 19 through 22. Install Loop Expansion Module, VF1054-00 to provide a second Class A loop at SLC 2 terminals 38 through 41.

Terminate unused loops of the Elite-RS Panel with zero-ohm shorting-jumpers. Connect zero-ohm shorting-jumpers on the Elite-RS Panel from OUT (-) to IN (-) and OUT (+) to IN (+). The Elite-RS Panel provides a trouble signal when unused loops are not terminated. SLC loops of the Elite-RS Panel are supervised.

SLC loops must be wired with Short Circuit Isolator Modules to comply with NFPA 72, Class A Style 7. Short Circuit Isolator Modules protect SLC loop devices from single-loop-shorts.

During an SLC loop short-circuit:

- The closest Short Circuit Isolator Modules to the short-circuit activate and respond by lighting their LED.
- Devices between the Short Circuit Isolator Modules are isolated and inoperative.
- Other devices on the SLC loop remain operational.
- The VES Elite-RS Panel indicates a trouble condition.

To install Class A, Style 6 and Style 7 SLC loops:

- Do not use T-taps on Class A SLC loops.
T-taps are not permitted for use on Class A SLC loops.
- Do not permit outgoing loops and return-side loops to share the same conduit or cable.
Feed outgoing and return-side loops separately.
- Refer to NFPA 72 for additional Class A requirements.

NFPA 72, Style 7

Connect wiring in compliance with NFPA 72, Class A, Style 7 requirements. For Class A, style 7 compliance, each device must be wired in a Closed Nipple with two surrounding Short Circuit Isolator Modules. The two Short Circuit Isolator Modules and the addressable device are enclosed individually or are shared in a common enclosure. If they are enclosed individually, the individual enclosures must be joined by “closed-nippling”.

When using Class A, Style 7 wiring, the Short Circuit Isolator Module must be installed before and after each addressable device on the SLC loop. Conduit must enclose wiring of the first and last Short Circuit Isolator Module on the SLC loop.

Isolator Modules shall be connected less than five feet from loop-terminal-connections of the Elite-RS Panel to maintain compliance with Class A, Style 7 requirements. Closed Nipple devices share a common enclosure and include single housings or raceways.

Common Enclosure

The figure below illustrates the “common enclosure” type of Closed Nipple connection containing two short circuit isolator modules and a sensor:

Figure 3-17
Common Enclosure

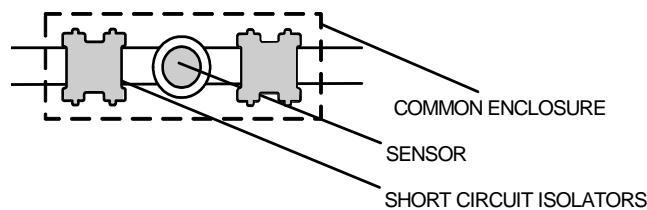

Reference manufacturer specifications for Short Circuit Isolator Module and Sensor connections.

Individual Enclosures

SLC loop connections must include closed nippling and conduit nippling to maintain compliance with individual enclosures under NFPA 72, Class A, Style 7 requirements. Closed nippling encloses individual devices on SLC loops and conduit nippling encloses wiring between these individual enclosures.

The figure below illustrates the use of closed nippling and conduit nippling on an SLC loop of the Elite-RS Panel:

Figure 3-18
Individual Enclosure

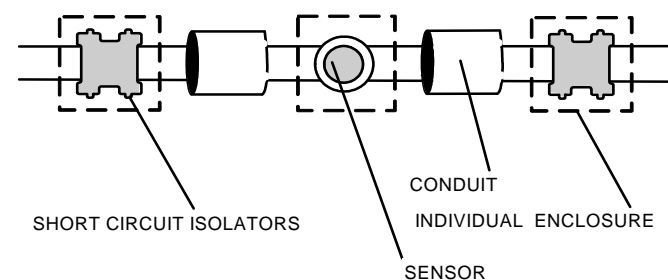

Reference manufacturer specifications for Short Circuit Isolator Module and Sensor connections.

The figure below illustrates a Class A, Style 7 wiring example using three closed nipple enclosures on SLC Loop 1:

Figure 3-19
Class A, Style 7 Wiring Example

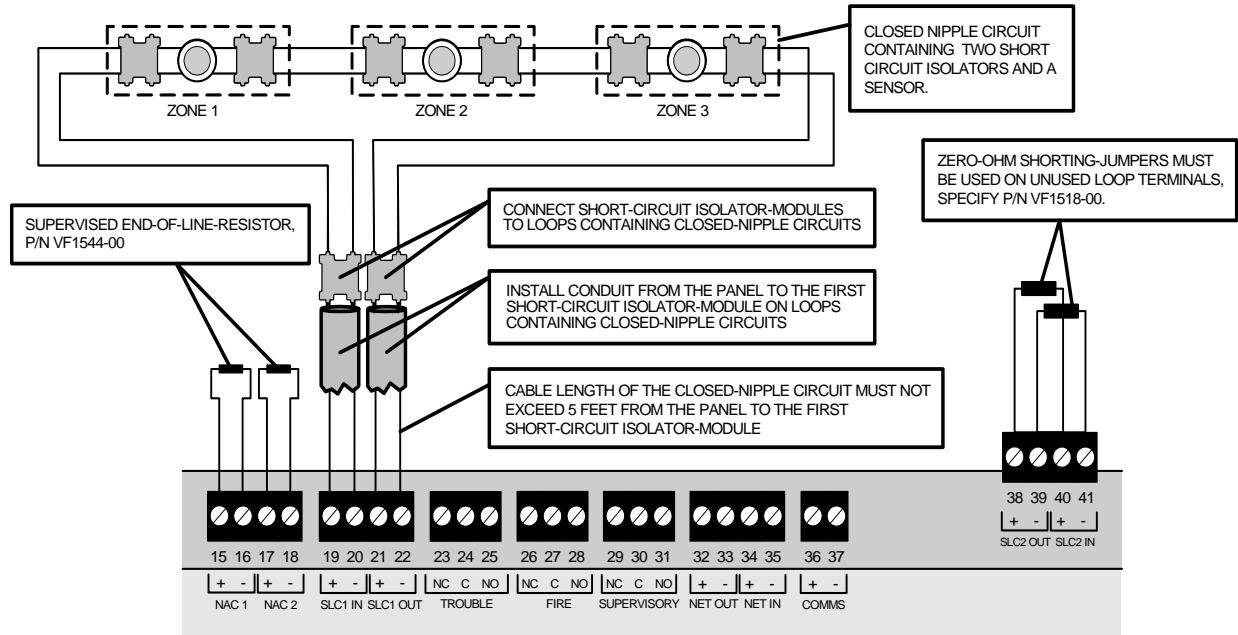

Reference manufacturer specifications for Short Circuit Isolator Module and Sensor connections.

Connect Short Circuit Isolator Modules less than five feet from the loop terminals of the Elite-RS Panel to maintain compliance with Class A, style 7 requirements.

NFPA 72, Style 6

For Class A, Style 6 compliance, the Short Circuit Isolator Modules may be located at strategic locations based on the discretion of the designer or installer.

Connecting Class B Loops

The Elite-RS Panel provides Class B loop connections at SLC 1 terminals 19 through 22. Install Loop Expansion Module, VF1054-00 to provide a second Class B loop at SLC 2 terminals 38 through 41.

Terminate used and unused SLC loops with zero-ohm shorting-jumpers. Connect zero-ohm shorting-jumpers from OUT (-) to IN (-) and OUT (+) to IN (+). The Elite-RS Panel provides a trouble signal when unused loops are not terminated. SLC loops of the Elite-RS Panel are supervised.

The figure below illustrates Class B, Style 4 connections on SLC 1 of the Elite-RS Panel:

Figure 3-20
Class B, Style 4 Connections

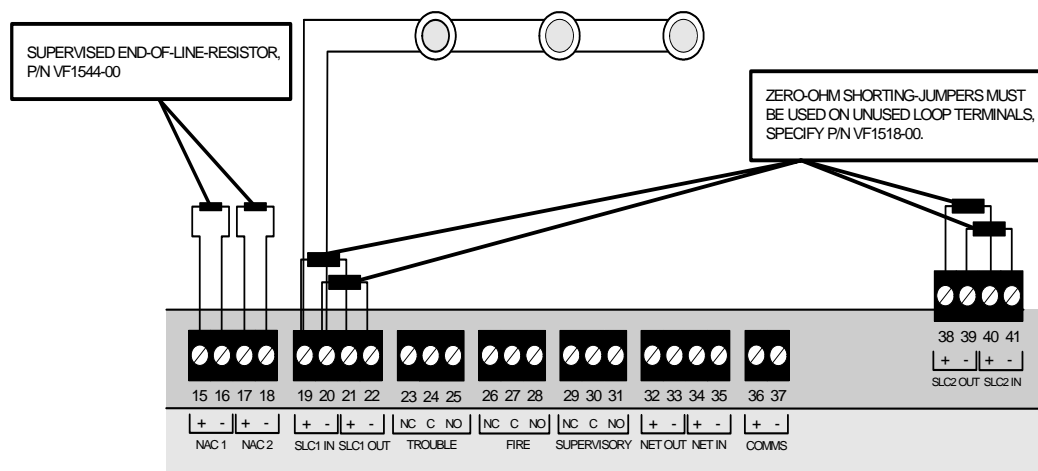

Reference manufacturer specifications for Short Circuit Isolator Module and Sensor connections. The Loop termination jumpers shown are provided in Resistor Kit (8) Zero Ohm. End Of Line Resistors (EOLRs) are used on Class B and not used on Class A, style 6 or 7 SLC loops.

Installing SLC Devices

This section describes installation requirements and constraints for SLC devices on the Elite-RS Panel. The SLC devices described in this section include detectors, addressable notification appliances and output modules.

Detector Spacing

Install SLC detectors with spacing as specified in section 90.19 of UL 864, 9th edition where units employing the multiple detector operation shall include guidelines for installing a minimum of two detectors in each protected space and to reduce the detector installation spacing to 0.7 times the linear spacing in accordance with National Fire Alarm Code, NFPA 72. Also reference 55.3.1 and 55.3.2 of UL 864, 9th edition for these detector spacing requirements.

Output Modules Controlling Notification Appliances

Not more than one notification zone shall be affected by a fault condition when installing output modules on SLC loops for controlling notification appliances. Install devices on an SLC loop of the Elite-RS Panel containing one of the following methods to meet this requirement:

- Perform an SLC loop installation that does not contain output devices.
- Perform an SLC loop installation where output devices are in one zone.
- Perform a Class A, Style 7 SLC loop installation where output devices are in different zones.
- Perform a Class A SLC loop installation with output devices in separate zones, short-circuit-isolators on SLC Loops and output devices on SLC loops with separate notification zones.

Reference “Connecting Class A Loops” for example-circuits containing these features.

Section 51.4.3 of UL 864, 9th edition specifies that a single break, single ground, or wire-to-wire fault on the installation conductors of a signaling line circuit for use with addressable notification appliances or modules shall not effect operation of more than one notification zone.

Silencing Notification Appliances

Notification Appliance (NA) silencing on the Elite-RS Panel meets exception 1, item 33.3.4. of UL 864, 9th edition. Individual NA zones can be re-sounded by addressable loops on the Elite-RS Panel after receiving the global silence command for multiple NA zones.

Exception 1 states, “When a system is intended to provide signaling service to two or more physically separated buildings or zones, re-energizing of the notification appliance circuits only on a zone basis meets the intent of the requirement.”

NAC Synchronization

NAC 1 and 2 outputs on the Elite-RS Panel can be connected for dual-output synchronization. These NAC outputs cannot be utilized for cross-panel synchronization.

Synchronized device connections on multiple Elite-RS Panels require special conditions when installing audible and visual Notification Appliances:

Audible Devices The installation of synchronized-audible notification appliances on one control panel shall not be installed in hearing range of another control panel operating synchronized-audible notification appliances. *NAC outputs on the Elite-RS Panel are synchronized however these outputs cannot be synchronized with other control panels operating synchronized-audible notification appliances.*

Visual Devices The installation of synchronized-visual notification appliances on one control panel shall not be installed in the line-of-sight of another control panel operating synchronized-visual notification appliances. *NAC outputs on the Elite-RS Panel are synchronized however these outputs cannot be synchronized with other control panels operating synchronized-visual notification appliances.*

Connecting NAC Devices

Connect NAC devices to terminals 15 and 16 of NAC channel 1 or terminals 17 and 18 of NAC channel 2. NAC channels 1 and 2 can be operated simultaneously provided current loading on each output is within Elite-RS specifications. NAC channels 1 and 2 are supervised.

Reference Appendix A, "Specifications" for operating limits of these NAC outputs.

To install Notification Appliance Circuits (NACs) on the Elite-RS Panel:

- 1 Connect Notification Appliances and End-Of-Line-Devices to the NAC channel.
- 2 Connect End-Of-Line- to unused NAC channels.
- 3 Maintain the limit for maximum wire length of the circuit.

The figure below illustrates an example of Class B, Style Y Notification Appliances on NAC 1.

Figure 3-21
Connecting NAC Devices

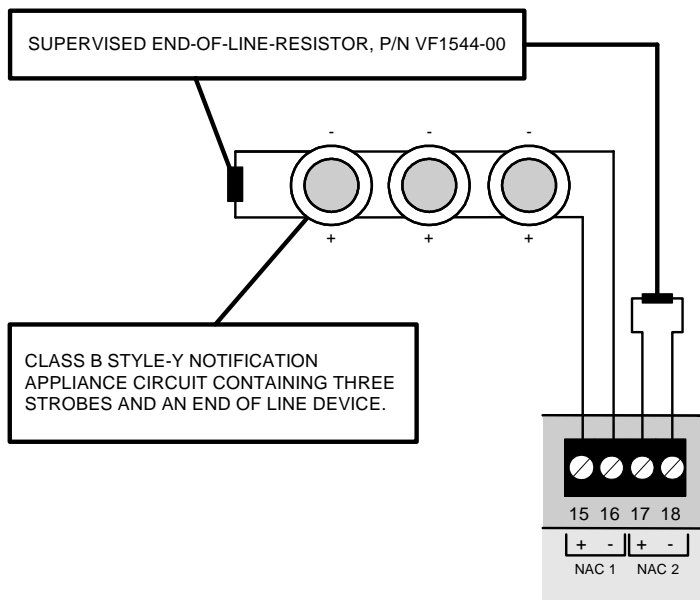

Connecting Auxiliary 24 VDC

The 24 V OUT and AUX 24 V power-source can be used to operate expansion-boards or low-current auxiliary-devices. Devices connected to these terminals must not draw current in excess of 360 mA on each of these outputs. Connect circuits to terminals 11 and 12 for the 24 V OUT power-source. Connect circuits to terminals 13 and 14 for the AUX 24 V power-source.

Provide cabling connections to these outputs using wire with a 3 volt maximum line loss.

Maintain these connections using the wire gages defined in Appendix A, Specifications.

Reference Appendix B, "Equipment List" for the list of devices authorized for these outputs.

Relay Contacts

Configurable dry Form C relays are located on the Elite-RS Panel for providing contact-actuation. The relays can be operated from default parameters or configured for specific functions in Loop Explorer or eSP Discovery.

Relay contacts of the Elite-RS Panel include:

- Trouble** The default operation of this relay is set to perform a Trouble output. Configurable settings are provided for Delay, Alarm Silence, Zone and Location Text. Default settings for these attributes are disabled from operating.
- Fire** The default operation of this relay is set to perform a General Alarm and Emergency output. Configurable settings are provided for Delay, Alarm Silence, Zone and Location Text. Default settings for these attributes are disabled from operating.
- Supervisory** The default operation of this relay is set to perform a Supervisory Alarm output and the Alarm Silence button is enabled for operating. Configurable settings are provided for Delay, Zone and Location Text. Default settings for these attributes are disabled from operating.

The figure below illustrates an example circuit using the normally-open contacts of the trouble relay:

Figure 3-22
Trouble Relay Example

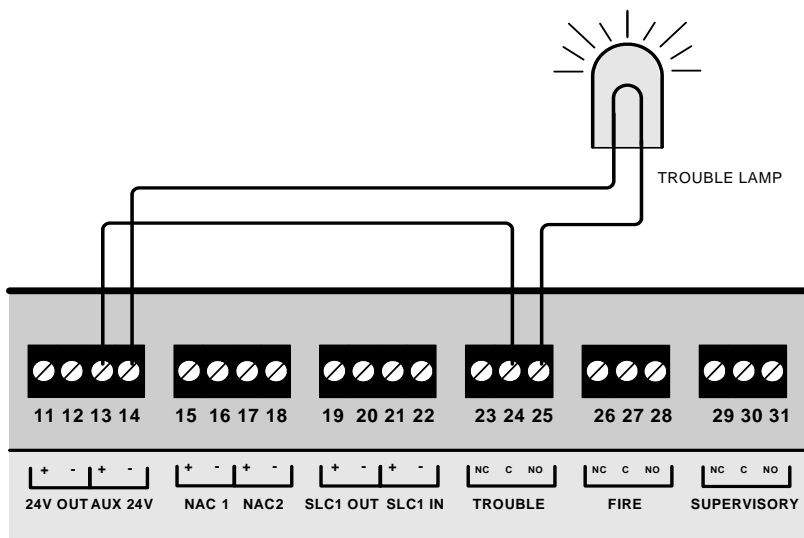

The adjacent figure illustrates a trouble-condition caused by the absence of end-of-line resistors and end-of-line-devices on terminals of the Elite-RS Panel.

Installing Municipal Boxes

The figure below illustrates typical municipal box connections of the Elite-RS Panel:

Figure 3-23
Municipal Box Connections

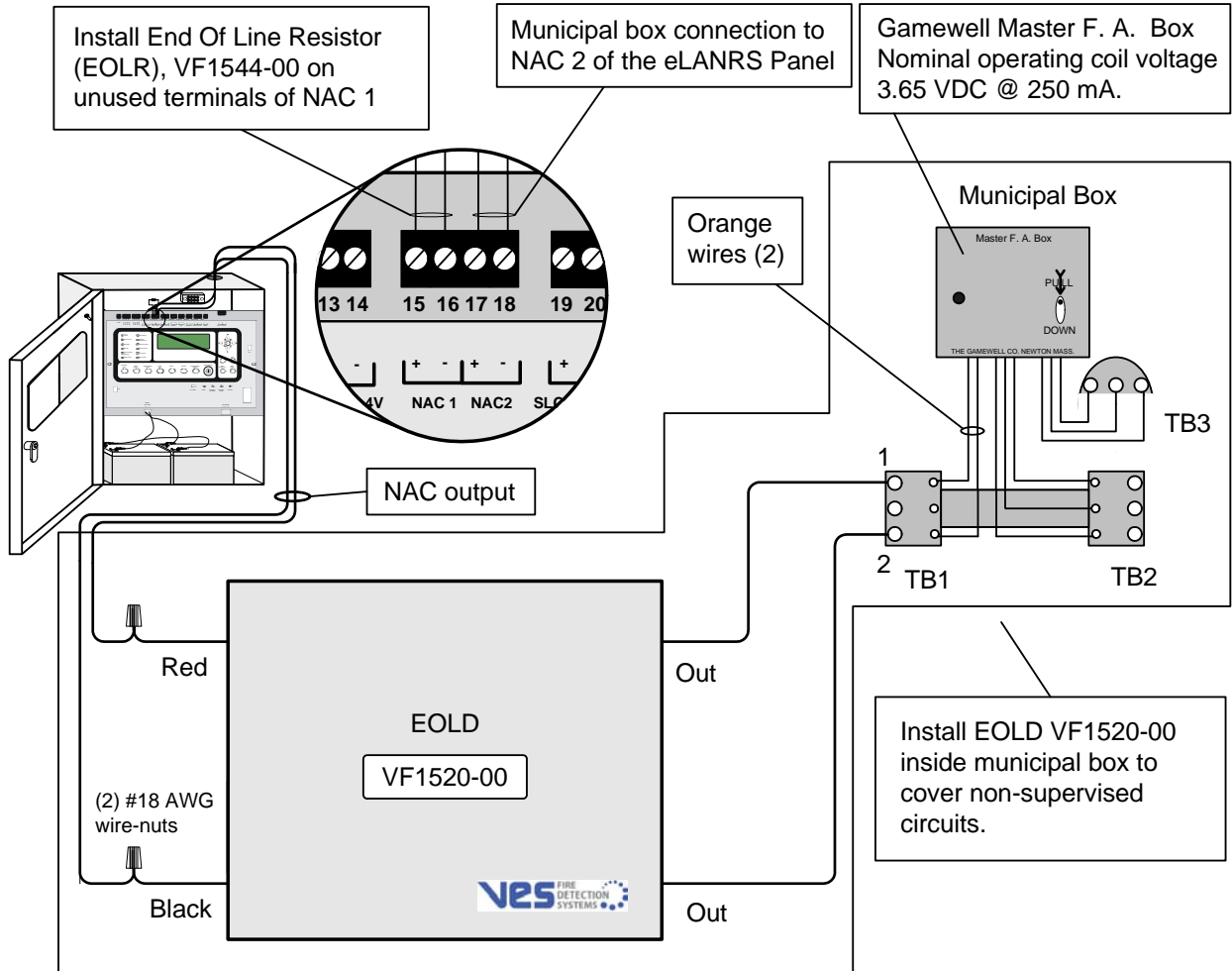

Perform this installation to connect the Gamewell Master F. A. Box for municipal-station notification. *Install this product in accordance with NFPA 72, NEC 70, the National Electrical Code and all local codes.* Each NAC output provides a regulated 24 VDC, 1.6A maximum output when a fire condition is reported to the Elite-RS Panel.

Terminate all connections using three 18 AWG wire-nuts. The maximum wire-length between the Elite-RS and the EOLD must not exceed 847 feet of 18 AWG wire. The “Out” leads of the EOLD shall connect directly to the terminal block of the municipal box.

Testing the Installation

Perform the following before testing the Elite-RS Panel:

- 1 Connect loops, sounder circuits, inputs and outputs to the control panel.
- 2 Confirm that correct connections exist between the batteries and the power supply.
- 3 Apply AC power to the Elite-RS Panel.
- 4 Verify that the panel display illuminates.
- 5 Perform an AUTO LEARN and confirm that the Front-Panel Menu does not contain errors.

AUTO LEARN is a feature of the Elite-RS Panel for testing the health of external devices and connections. Operate AUTO LEARN through Access Level 3 of the front-panel menu. External devices receive default configuration settings during the AUTO LEARN sequence and circuit connections are tested for opens, shorts and ground fault conditions.

CAUTION!



The Elite-RS Panel buzzer may activate following AUTO LEARN. Buzzer activation indicates that an installation error condition exists. Disable the buzzer after determining the cause of the alarm and then rectify the installation problem.

- 6 Test the Elite-RS Panel lamps.

Confirming a Successful Installation

The Elite-RS Panel installation is successful when it completes the following sequence of front-panel displays:

- 1 Panel Initialization Tests internal hardware and firmware responsible for operating loop devices.
- 2 Loop Initialization Configures the Elite-RS Panel to existing loop conditions.
- 3 Normal-Standby Displays the Normal Standby after a successful boot process.

The front-panel displays shown are intended for reference only.

Panel initialization

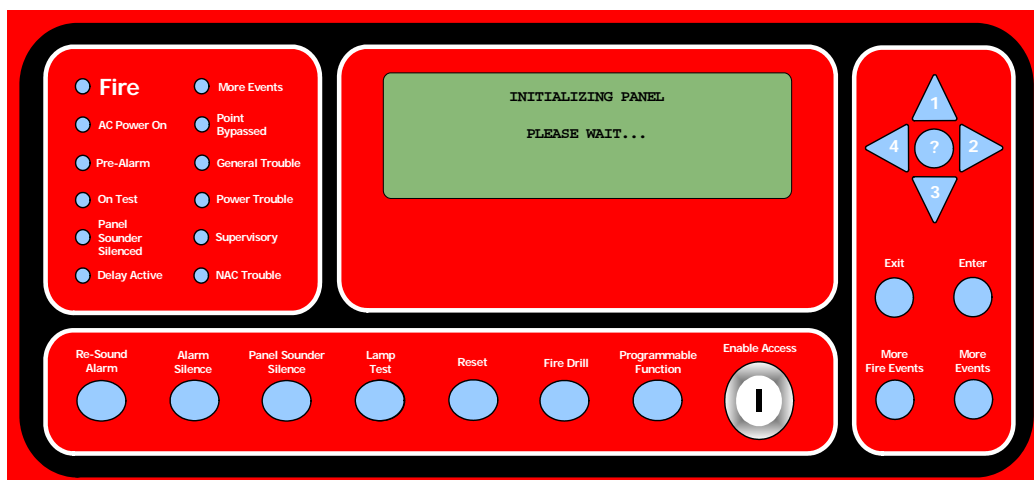

Loop initialization

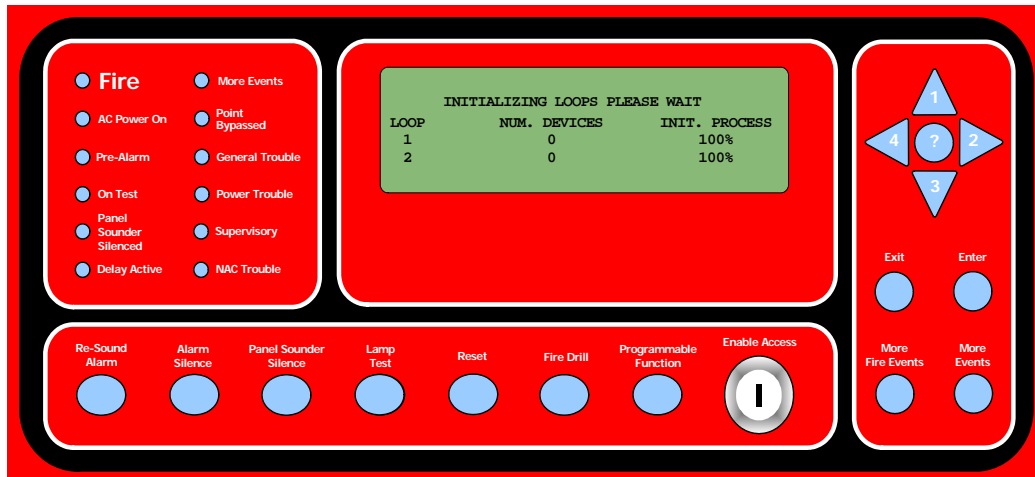

Normal-Standby



Initializations performed during the booting process are complete when the Normal Standby condition displays. The Normal Standby condition indicates that the Elite-RS Panel is operating properly and that the installation was successful.

Testing the Panel Lamps

- 1 Press the lamp test button to light the front-panel lamps.

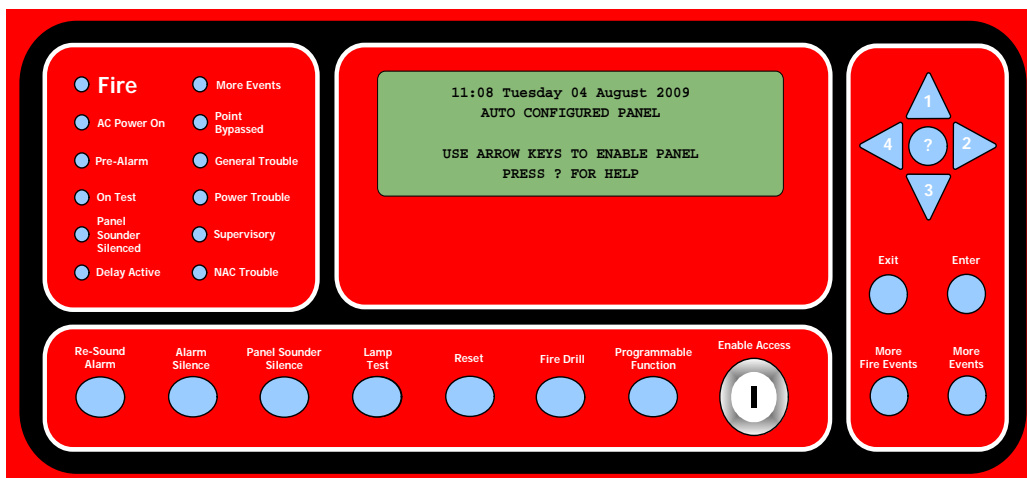

- 2 Verify that all front-panel lamps are lit.

*Contact the help desk if front-panel lamps do not light.
Reference Section 2, “Overview” for a description of Lamp Test operation.*

Trouble-Silence Test

This test checks the silencing operation of the Elite-RS Panel during a trouble condition.

To perform the Trouble-Silence Test:

- 1 Confirm that the Elite-RS Panel is in the Normal-Standby mode before performing this test. The Normal-Standby mode is shown below:

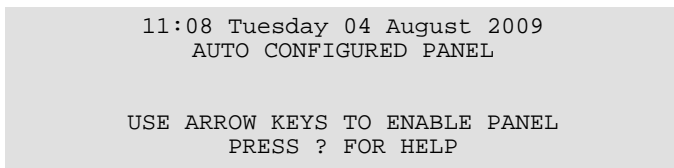

The first line of the message format contains the time, day and date.
The second line of the format contains a default or user defined message.

- 2 Press any numeric arrow-button on the right-control-panel or turn the enable key-switch to the right to display “SET ACCESS LEVEL 2 MENU” on the LCD.
- 3 Provide Access Level 2 authorization and then press Enter on the right-control-panel.

- 4 Remove the black-lead from the negative terminal of the standby-battery in the Elite-RS Panel.

The following conditions occur on the front-panel of the Elite-RS Panel:

- The General Trouble LED flashes yellow.
- The Power Trouble LED flashes yellow.
- The internal sounder annunciates.
- The LCD display provides the following message to identify this condition:

```
ALM=000  TBL=0002  SUP=000  OOS=000  REL=00
          * TROUBLE *
NODE=1  PANEL NAME
Low battery voltage
                                     More Events
```

In the example display above the trouble condition is identified by * TROUBLE * and "TBL=0002". TBL=0002 indicates that two trouble conditions exist. The first trouble condition, "Low battery voltage" is displayed above. The second trouble condition, "battery disconnected" is displayed in the MORE EVENTS menu.

- 5 Identify the second trouble condition on the Elite-RS Panel.

To display the second trouble condition on the Elite-RS Panel:

- 1 Press More Events on the front-panel of the Elite-RS.
- 2 Press 3 on the central-key-pad to scroll down to "MORE TROUBLE".
- 3 Press 2 on the central-key-pad to display "battery disconnected".

```
MORE TROUBLE 001/002
          * TROUBLE *
NODE=1  PANEL NAME
Battery disconnected
Use UP/DOWN arrow keys to scroll events
```

- 6 Silence the sounder on the Elite-RS Panel.

Press the Panel Sounder Silence button on the front-panel to silence the internal alarm of the Elite-RS Panel. The following conditions occur on the front-panel of the Elite-RS Panel:

- The General Trouble LED flashes yellow.
- The Power Trouble LED flashes yellow.
- The internal sounder does not annunciate.
- The LCD display provides the following message to identify this condition:

```
ALM=000  TBL=0002  SUP=000  OOS=000  REL=00
          * TROUBLE *
NODE=1  PANEL NAME
Low battery voltage
                                     More Events
```

- 7 Re-connect the black-lead to the negative terminal of the standby-battery in the Elite-RS Panel.

The LCD display provides the following message to identify the return to the normal-standby condition:

```
11:08 Tuesday 04 August 2009
      AUTO CONFIGURED PANEL
```

```
USE ARROW KEYS TO ENABLE PANEL
      PRESS ? FOR HELP
```

Troubleshooting

This section describes how to troubleshoot using the Front-Panel Menu of the Elite-RS Panel.

Perform troubleshooting techniques on the Elite-RS Panel when messages on the front-panel are not consistent with those described in “Confirming a Successful Installation”.

Options on the Front-Panel Menu include:

Test Zones	Tests zones 1 to 500 including local NACs, panel outputs and loop outputs.
Event Log	Provides event log view function as well as an event log clear function.
Loop Data Test	Tests devices connected to Elite-RS Panel loops.

Test Zones

The TEST ZONES menu tests NAC, panel and loop outputs. Options for this menu feature are described below:

Test Zones	Default = 1	Sets the test for zones 1 to 500.
Local NACs	Default = On	Tests Elite-RS Panel NACs. Audible and visual notification circuits activate for 3-second durations during this test.
Loop Outputs	Default = Off	Tests loop driven outputs other than the loop sounders.

Refer to Section 4, “Front-Panel Menu” for more information about Test Zones.

Test Zones reverts to the MAIN MENU after 25 seconds when there is no navigation activity on the front-panel display.

To troubleshoot using the TEST ZONES menu feature:

- 1 Press 3 on the upper-control-pad to display the SET ACCESS LEVEL 2 MENU.

```
SET ACCESS LEVEL 2 MENU
Enter Access Level 2 Password
Use numbered arrow keys
*****
Access will automatically expire after
120 seconds if no key is pressed.
ENTER TO PROCEED - EXIT TO QUIT
```

- 2 Type the five digit code in the password field and press Enter.
The default password is 22222.

- 3 Press 3 on the upper-control-pad to display the MAIN MENU.

```
MAIN MENU - V07.0007A
>DISABLEMENTS
VIEW DeviceS
TEST ZONES
SET SYSTEM TIME
SENSOR MAINTENANCE EARLY WARNING
ACCESS LEVEL 3
```

- 4 Press 3 on the upper-control-pad to navigate down to TEST ZONES.

```
MAIN MENU - V07.0007A
DISABLEMENTS
VIEW DeviceS
>TEST ZONES
SET SYSTEM TIME
SENSOR MAINTENANCE EARLY WARNING
ACCESS LEVEL 3
```

- 5 Press 2 on the upper-control-pad to select TEST ZONES.

```
TEST ZONES MENU
>TEST ZONE: 01 - (NORMAL)
Use Up/Down arrow keys to select.
Press > to proceed. Press < to go back.
```

- 6 Press 1 on the upper-control-pad to select a TEST ZONE from 1 to 500.

- 7 Press 2 on the upper-control-pad to select the TEST ZONE option for LOCAL NAC: - ON.

```
TEST ZONE: 1
>LOCAL NAC: - ON
Use Up/Down arrow keys to select.
Press > to proceed. Press < to go back.
```

- 8 Press 1 on the upper-control-pad to set LOCAL NAC: - OFF.

- 9 Press 2 on the upper-control-pad to select the TEST ZONE option for PANEL OUTPUTS: -OFF.

```
TEST ZONE: 1

>PANEL OUTPUTS: - OFF

Use Up/Down arrow keys to select.
Press > to proceed. Press < to go back.
```

- 10 Press 1 on the upper-control-pad to set PANEL OUTPUTS: - ON.

- 11 Press 2 on the upper-control-pad to select the TEST ZONE option for Loop OUTPUTS: - OFF.

```
TEST ZONE: 1

>Loop OUTPUTS: - OFF

Use Up/Down arrow keys to select.
Press > to proceed. Press < to go back.
```

- 12 Press 1 on the upper-control-pad to set Loop OUTPUTS: - ON.

- 13 Press 2 on the upper-control-pad to display the test mode for the TEST ZONE:

```
START TEST MODE ?
TEST ZONE: 1
Test Mode will expire after 15 minutes if zone is idle.
Press ENTER to start Test Mode.
Press EXIT to quit.
Press < to go back.
```

- 14 Press ENTER on the upper-control-pad to begin the test or press EXIT to quit.
Test mode runs for 15 minutes.

During the test:

- The "On Test" LED illuminates continuously
- The More events LED illuminates continuously
- The General Trouble LED blinks.
- The internal buzzer sounds intermittently

The front-panel display provides the following message:

```
ZONES IN Alarm=000 TRBL=0001 DISAB=0000
* TROUBLE *
NODE=1 AUTOLEARN
Test mode
More Events
```

- 15 Press ENTER (again) to cancel the test.

Event Log

All FACP system activities are displayed in the event log. Operators of the Elite-RS Panel can use the event log to trouble-shoot system problems or confirm conditions such as Fire Drills.

Refer to Section 4, “Front-Panel Menu” for more information about Event Log.

Displaying the Event Log

To display the Event Log:

- 1 Press 3 on the upper-control-pad to display the SET ACCESS LEVEL 2 MENU.

```
SET ACCESS LEVEL 2 MENU
Enter Access Level 2 Password
Use numbered arrow keys
*****
Access will automatically expire after
120 seconds if no key is pressed.
ENTER TO PROCEED - EXIT TO QUIT
```

- 2 Type the five digit code in the password field and press Enter. The default password is 22222.
- 3 Press 3 on the upper-control-pad to display the MAIN MENU.

```
MAIN MENU - V07.0007A
>DISABLEMENTS
VIEW DeviceS
TEST ZONES
SET SYSTEM TIME
SENSOR MAINTENANCE EARLY WARNING
ACCESS LEVEL 3
```

- 4 Press 1 on the upper-control-pad to navigate to ACCESS LEVEL 3.

```
MAIN MENU - V07.0007A
DISABLEMENTS
VIEW DeviceS
TEST ZONES
SET SYSTEM TIME
SENSOR MAINTENANCE EARLY WARNING
>ACCESS LEVEL 3
```

- 5 Press 2 on the upper-control-pad to display the SET ACCESS LEVEL 3 MENU:

```
SET ACCESS LEVEL 3 MENU
Enter Access Level 3 Password
Use numbered arrow keys
*****
ENTER TO PROCEED - EXIT TO QUIT
```

- 6 Type the five digit code in the password field and press Enter.
The default password is 33333.

```
ACCESS LEVEL 3 MENU
>EDIT CONFIGURATION
  SET TIMES
  VIEW PRINT EVENT LOG
  PRINT CONFIGURATION
  SYSTEM DISABLEMENTS
  Loop DATA TEST
```

- 7 Press 3 on the upper-control-pad and navigate to EVENT LOG.

```
ACCESS LEVEL 3 MENU
EDIT CONFIGURATION
SET TIMES
>VIEW PRINT EVENT LOG
  PRINT CONFIGURATION
  SYSTEM DISABLEMENTS
  Loop DATA TEST
```

- 8 Press 2 on the upper-control-pad to display the VIEW/CLEAR EVENT LOG MENU.

```
VIEW/CLEAR EVENT LOG MENU
>View Event Log
  Print Event Log
  Clear Event Log
  View Archived Event Log
  Clear Archived Event Log
```

- 9 Press 2 on the upper-control-pad to display the View Event Log.

```
SELECT EVENT TYPES TO VIEW
>FIRE- 0
  PRE-Alarm- 1
  TROUBLE- 0
  DISABLEMENT- 0
  OTHER EVENTS- 0
  ALL EVENTS- 0
```

- 10 Press 3 on the upper-control-pad to scroll down the list of event types.
- 11 Press 2 on the upper-control-pad to display the event type.
Event logs are not displayed when events are shown with zeros in "SELECT EVENT TYPES TO VIEW". An example of a pre-alarm condition is shown below:

```
VIEW PRE-Alarm EVENTS 001/016
    *PRE-Alarm: HEAT SENSOR ZONE 02 *
ADR=011.00 Loop=2 ND=1 AUTOLEARN
TIME 10:35 02/18/2004
Pre-Alarm
Use UP/DOWN arrow keys to scroll events
```

- 12 Press 4 on the upper-control-pad to go back or press Exit to quit.

Clearing the Event Log

The Clear Event Log feature removes the event log from Elite-RS Panel memory.

To clear the event log:

- 1 Press 3 on the upper-control-pad to display the SET ACCESS LEVEL 2 MENU.

```
SET ACCESS LEVEL 2 MENU
Enter Access Level 2 Password
Use numbered arrow keys
*****
Access will automatically expire after
120 seconds if no key is pressed.
ENTER TO PROCECEED - EXIT TO QUIT
```

- 2 Type the five digit code in the password field and press Enter.
The default password is 22222.
- 3 Press 3 on the upper-control-pad to display the MAIN MENU.

```
MAIN MENU - V07.0007A
>DISABLEMENTS
VIEW DeviceS
TEST ZONES
SET SYSTEM TIME
SENSOR MAINTENANCE EARLY WARNING
ACCESS LEVEL 3
```

- 4 Press 1 on the upper-control-pad to navigate to ACCESS LEVEL 3.

```
MAIN MENU - V07.0007A
DISABLEMENTS
VIEW DeviceS
TEST ZONES
SET SYSTEM TIME
SENSOR MAINTENANCE EARLY WARNING
>ACCESS LEVEL 3
```

- 5 Press 2 on the upper-control-pad to display the SET ACCESS LEVEL 3 MENU:

```
SET ACCESS LEVEL 3 MENU
Enter Access Level 3 Password
Use numbered arrow keys
*****
ENTER TO PROCEED - EXIT TO QUIT
```

- 6 Type the five digit code in the password field and press Enter.
The default password is 33333.

```
ACCESS LEVEL 3 MENU
>EDIT CONFIGURATION
SET TIMES
EVENT LOG
SYSTEM DISABLEMENTS
Loop DATA TEST
```

- 7 Press 3 on the upper-control-pad and navigate to EVENT LOG.

```
ACCESS LEVEL 3 MENU
EDIT CONFIGURATION
SET TIMES
>EVENT LOG
SYSTEM DISABLEMENTS
Loop DATA TEST
```

- 8 Press 2 on the upper-control-pad to display the VIEW/CLEAR EVENT LOG MENU.

```
VIEW/CLEAR EVENT LOG MENU
>View Event Log
Clear Event Log
```

- 9 Press 3 on the upper-control-pad to scroll down to Clear Event Log.

- 10 Press 2 on the upper-control-pad to display the CLEAR EVENT LOG MENU.

```
CLEAR EVENT LOG MENU
Event Log has 1 entries
Press ENTER to clear Event Log.
Press EXIT to quit.
Press < to go back.
```

- 11 Press ENTER to clear the Event log.

```
CLEAR EVENT LOG MENU
Event Log has 0 entries
Press ENTER to clear Event Log.
Press EXIT to quit.
Press < to go back.
```

- 12 Press EXIT to quit or press 4 to go back.

Loop Data Test

The Loop Data Test feature tests loop devices connected on the Elite-RS Panel. Refer to Section 4, “Front-Panel Menu” for more information about the Loop Data Test feature.

To perform the Loop Data Test:

- 1 Press 3 on the upper-control-pad to display the SET ACCESS LEVEL 2 MENU.

```
SET ACCESS LEVEL 2 MENU
Enter Access Level 2 Password
Use numbered arrow keys
*****
Access will automatically expire after
120 seconds if no key is pressed.
ENTER TO PROCECEED - EXIT TO QUIT
```

- 2 Type the five digit code in the password field and press Enter.
The default password is 22222.
- 3 Press 3 on the upper-control-pad to display the MAIN MENU.

```
MAIN MENU - V07.0007A
>DISABLEMENTS
VIEW DeviceS
TEST ZONES
SET SYSTEM TIME
SENSOR MAINTENANCE EARLY WARNING
ACCESS LEVEL 3
```

- 4 Press 1 on the upper-control-pad to navigate to ACCESS LEVEL 3.

```
MAIN MENU - V07.0007A
DISABLEMENTS
VIEW DeviceS
TEST ZONES
SET SYSTEM TIME
SENSOR MAINTENANCE EARLY WARNING
>ACCESS LEVEL 3
```

- 5 Press 2 on the upper-control-pad to display the SET ACCESS LEVEL 3 MENU:

```
SET ACCESS LEVEL 3 MENU
Enter Access Level 3 Password
Use numbered arrow keys
****
ENTER TO PROCEED - EXIT TO QUIT
```

- 6 Type the five digit code in the password field and press Enter.
The default password is 33333.

```
ACCESS LEVEL 3 MENU
>EDIT CONFIGURATION
SET TIMES
EVENT LOG
SYSTEM DISABLEMENTS
Loop DATA TEST
```

- 7 Press 1 on the upper-control-pad scroll up to Loop DATA TEST.

```
ACCESS LEVEL 3 MENU
EDIT CONFIGURATION
SET TIMES
EVENT LOG
SYSTEM DISABLEMENTS
>Loop DATA TEST
```

- 8 Press 2 on the upper-control-pad to display the Loop DATA TEST.

```
Loop DATA TEST
>SELECT Loop 1
SET TIMES
```

- 9 Press 2 on the upper-control-pad to START TEST.

```
Loop DATA TEST
>START TEST
```

- 10 Press 2 on the upper-control-pad to begin the test .

```
Loop DATA TEST ( Loop: 1)
Start Date : 12/10/2009 10:37:00
Good Readings: 0100800
Bad Readings: 0000000
Current Date: 12/10/2009 10:58:13
```

The test example above indicates that the loop test was started 12/10/2009 at 10:37. It also reveals that over one-hundred-thousand test readings have been recorded since the beginning of the test.

- 11 Press 4 on the upper-control-pad to back out of the Loop DATA TEST screen.

```
Loop DATA TEST
>VIEW DATA
CANCEL TEST
```

- 12 Press 3 on the upper-control-pad to scroll down to CANCEL TEST.

- 13 Press 2 on the upper-control-pad to display the window for stopping the test.

```
Loop DATA TEST
PLEASE PRESS ENTER TO STOP TEST
```

- 14 Press ENTER to cancel the loop test.

```
Loop DATA TEST
>SELECT Loop 1
```

- 15 Press EXIT to return to the main menu.

```
11:12 Thursday December 10 2009
AUTO CONFIGURED PANEL

USE ARROW KEYS TO ENABLE PANEL
PRESS ? FOR HELP
```

This page intentionally left blank.

Section 4

Front-Panel Menu

This section describes the operation of the Front-Panel Menu on the Elite-RS Panel. Navigate the menu using the upper-control-pad of the Elite-RS Panel. The Elite-RS Panel provides navigation of the Front-Panel Menu for Access Level 2 and Access Level 3. Access Level 2 controls front-panel-buttons and menu settings. Access Level 3 controls Elite-RS Panel system settings.

To operate the Front-Panel Menu of the Elite-RS Panel:

- 1 Confirm that the display of the Front-Panel Menu does not contain errors after performing AUTO LEARN.
AUTO LEARN is a feature of the Elite-RS Panel for testing the health of external devices and connections. Operate AUTO LEARN through Access Level 3 of the front-panel menu. External devices receive default configuration settings during the AUTO LEARN sequence and circuit connections are tested for opens, shorts and ground fault conditions.
Reference "Section 3, Troubleshooting" if error messages are displayed on the front-panel following the AUTO LEARN process.
- 2 Press 3 on the upper-control-pad to display the SET ACCESS LEVEL 2 MENU.
- 3 Type the five digit code in the password field and press Enter.
The default password is 22222.
- 4 Press 3 on the upper-control-pad to display the MAIN MENU.
- 5 Press 3 on the upper-control-pad to navigate to LOCAL MENU.
- 6 Press 2 on the upper-control-pad to select LOCAL MENU and display MAIN MENU.
- 7 Press 1 on the upper-control-pad to navigate to ACCESS LEVEL 3.
- 8 Press 2 on the upper-control-pad to select ACCESS LEVEL 3 and display SET ACCESS LEVEL 3 MENU.
- 9 Type the five digit code in the password field and press Enter.
The default password is 33333.
- 10 Press 1 to navigate to ACCESS LEVEL 3 MENU.

The Front-Panel Menu display returns to the Main Menu when navigation activity stops for more than 25 seconds.

Access Level 2

Access Level 2 provides functions for:

- Disablements
- View Devices
- Test Zones
- Set System Time
- Sensor Maintenance Early Warning
- Access Level 3

```

MAIN MENU - V07.0007A
>DISABLEMENTS
VIEW DeviceS
TEST ZONES
SET SYSTEM TIME
SENSOR MAINTENANCE EARLY WARNING
ACCESS LEVEL 3

```

Disablements

The Disablements Menu provides an option for viewing and restoring disabled features as well as setting timed or un-timed disablements for loops, zones, addresses, audible devices and panel I/O:

```

DISABLEMENTS MENU
>DISABLE Loops
DISABLE ZONES
DISABLE ADDRESSES
DISABLE AUDIBLE DeviceS
DISABLE PANEL I/O
VIEW & RESTORE DISABLED FEATURES

```

The timed function provides a disablement-duration of 30 minutes to 24 hours and stops the disablement when the duration-time expires. The un-timed function provides an infinite disablement that stops when “cleared” on the menu.

Disable Loops

The DISABLE Loops function disables loop-devices from reporting fire signals to the Elite-RS Panel. This function does not disable loop-devices from reporting trouble and supervisory signals to the Elite-RS Panel.

CAUTION!



The DISABLE Loops function does not isolate the Elite-RS Panel from SLC connections. Disconnect SLC connections to the Elite-RS Panel when troubleshooting or when performing wiring changes.

Disable Zones

All detection devices, including manual pull stations, are disabled in the selected zone.

When a device is disabled, the Elite-RS Panel ignores the analog value reported by the device. All other faults for the device such as missing device, double address, internal fault, type changed and bad data are still reported by the Elite-RS Panel.

Disable Addresses

Any loop device can be disabled using this menu option. Sub-addresses may be individually disabled when using devices with more than one input or output.

When a device is disabled, the Elite-RS Panel ignores the analog value reported by the device. All other faults for the device such as missing device, double address, internal fault, type changed and bad data are still reported by the Elite-RS Panel.

Disable Audible Devices

This menu option disables all audible device outputs connected to the control panel. An audible device output is defined as any output that has been set to respond to Silence and Evacuate panel commands. Audible device outputs may be directly wired to NAC 1 and NAC 2 or loop driven devices.

The NAC Trouble indicator will be illuminated, as well as the Point Bypassed Indicator.

Disable Panel I/O

This menu option disables or enables panel input and output functions. Timed disabling can be set to occur between 30 minutes to 24 hours. Un-timed disabling can be set to occur indefinitely.

Panel Inputs

Programmable	Default = Enabled	Disables or enables the front-panel Programmable Function button.
Fire Drill	Default = Enabled	Disables or enables the front-panel Fire Drill button.

Panel Outputs

NAC 1	Default = Enabled	Disables or enables NAC 1 on Terminal X1 of the Main Board. To set these parameters using the Elite-RS Panel Front-Panel Menu: 1 Select ACCESS LEVEL 2 2 Select ACCESS LEVEL 3 3 Select EDIT CONFIGURATION 4 Select EDIT PANEL I/O 5 Select EDIT PANEL OUTPUTS 6 Scroll through the options for NAC CIRCUIT 1
NAC 2	Default = Enabled	Disables or enables NAC 2 on Terminal X1 of the Main Board. To set these parameters using the Elite-RS Panel Front-Panel Menu: 1 Select ACCESS LEVEL 2 2 Select ACCESS LEVEL 3 3 Select EDIT CONFIGURATION 4 Select EDIT PANEL I/O 5 Select EDIT PANEL OUTPUTS 6 Scroll through the options for NAC CIRCUIT 2

View & Restore Disabled Features

To cancel disablements, scroll through the menu options and toggle disablements to the normal condition. Another way to cancel disablements is to use the View / Restore Disablements option to scroll through active disablements and individually enable each disablement by pressing the Enter button.

View Devices

This menu option is used by experienced personnel to investigate system status and may help in fault finding. The View Devices option displays addresses connected to each detection circuit. For each address & sub-address, the LCD status display provides the device type, zone and location text.

Analog devices are displayed in the menu with indicators representing the connected device. Digital input devices such as the points of manual pull stations and switch monitor units are displayed as Normal or Activated. Output devices are displayed as either Off, Intermittent or Continuous.

Status conditions are displayed in the Devices By Loop or View Devices By Zone area of the menu.

Test Zones

Each zone may be individually put into a Test Mode condition.

Test Zone (1 – 500)

When test mode is selected, devices in the zone may be tested and the Elite-RS Panel will automatically reset after 3 seconds. When a zone is put into test mode, the user is prompted to select a number of test mode options. These options are retained for each zone, but may be changed at any time.

Local NAC On – Off (Default = On)

When set to the ON position, all NAC outputs will sound for the duration of the fire event. The NACs will be silenced when the panel automatically resets.

NAC devices may not activate within the three second fire period on systems operating high numbers of loop-powered NAC devices. Loop confirmation of these NAC devices may be intermittent under these conditions.

Loop Outputs On – Off (Default = Off)

When selected in the ON position, all loop driven outputs other than the loop NAC outputs will operate in accordance with their standard configuration.

Start Test Mode?

Initiate zone testing using this screen after setting parameters in Test Zone (1 – 500), Local NAC On – Off, Panel Outputs On – Off and Loop Outputs On – Off.

The screen display is:

```
Test Mode will expire after 15 minutes
if zone is idle.
Press ENTER to start Test Mode.
Press EXIT to quit.
Press < to go back,
```

A 15 minute timer begins decrementing when a zone is set in test mode. The test will automatically stop after the timer stops. The timer automatically resets to 15 minutes whenever a device is activated in the zone test.

Include Pull Stations Yes – No (Default = No)

When selected to the ON position, all manual pull stations will also be included in the Test Mode for the zone. The normal use of this facility is to set the Include Pull Stations to No and test all smoke detection devices in the zone. At this stage, all manual pull stations will still operate and will take the panel out of test mode. When all devices in the zone have been tested, then the zone is put into test, including manual pull stations.

All manual pull stations can then be tested and will operate the test mode when a zone (or zones) has been set to test mode, then a 15 minute timer is started. This timer will decrement and after 15 minutes the zone will be automatically taken out of test mode. Whenever a device is activated in the zone in test, the timer will automatically be reset to 15 minutes.

Set System Time

This menu option sets the panel date and time. Set the system time to log events in the event log.

Control panel changes performed in 2010 provide automatic compensation for daylight saving time.

Sensor Maintenance Early Warning

This option provides contamination status for Loop 1 and 2.

Events and Status

This section describes events and the status of the front-panel display while operating the Elite-RS Panel. The following events are described:

- Fire Event
- Trouble Event
- Pre Alarm Event

Fire Event

In the event of a fire, the red FIRE lamp and the appropriate Fire Zone indicator flash (if connected). Details of the fire activation (address and location text) display on the front-panel.

Fire warning NACs sound throughout the building and the panel fire relay contact energizes. The panel buzzer pulses, but can be silenced by pressing the Silence Buzzer button.

To silence fire NACs, press any of the menu navigation buttons and enter the Access 2 password then press the Enter button. Panel controls will be enabled and will remain enabled for one minute after pressing the last key. Pressing the Alarm Silence button will silence the NACs. The NACs can be started again by pressing the Re-Sound Alarm button. The system can be reset by pressing the Reset button.

Press the More Events button on the front-panel to display the status of more than two fire events.

The maximum Fire event delay setting shall be less than 10 seconds.

Trouble Event

If there is a fault on the system, the yellow General Trouble indicator will flash and there may be other fault LED indications which identify the nature of the fault. The Fault Contact and Fault Routing outputs will energize and the panel buzzer will sound continuously.

Details of the fault will be provided on the front-panel display. The panel buzzer can be silenced at any time by pressing the Silence Buzzer button.

Press the More Events button on the front-panel to display the status of more than two fire events.

The maximum Trouble event delay setting shall be less than 120 seconds.

Pre-alarm Event

Sensors or inputs can generate a pre-alarm. A pre-alarm is used to warn of a slow change in the analog level of detection devices. A smoldering fire can be an example of a condition that can cause a pre alarm event. When a pre-alarm is generated, the control panel will illuminate the pre-alarm LED and will sound the internal buzzer continuously. The address and location of the source of the pre-alarm will be indicated in the LCD status display.

The source of the pre-alarm input should be investigated. The panel buzzer can be silenced at any time by pressing the Silence Buzzer button.

Press the More Events button on the front-panel to display the status of more than two fire events.

The maximum Pre-Alarm event delay setting shall be less than 60 seconds.

Access Level 3

Access Level 3 of the Elite-RS Panel provides menu settings for:

- Edit Configuration
- Set Times
- View Event Log
- System Disablements
- Loop Data Test

Figure 4-1 illustrates a menu map describing menu commands for navigating Access Level 3:

Figure 4-1
Access Level 3 Menu

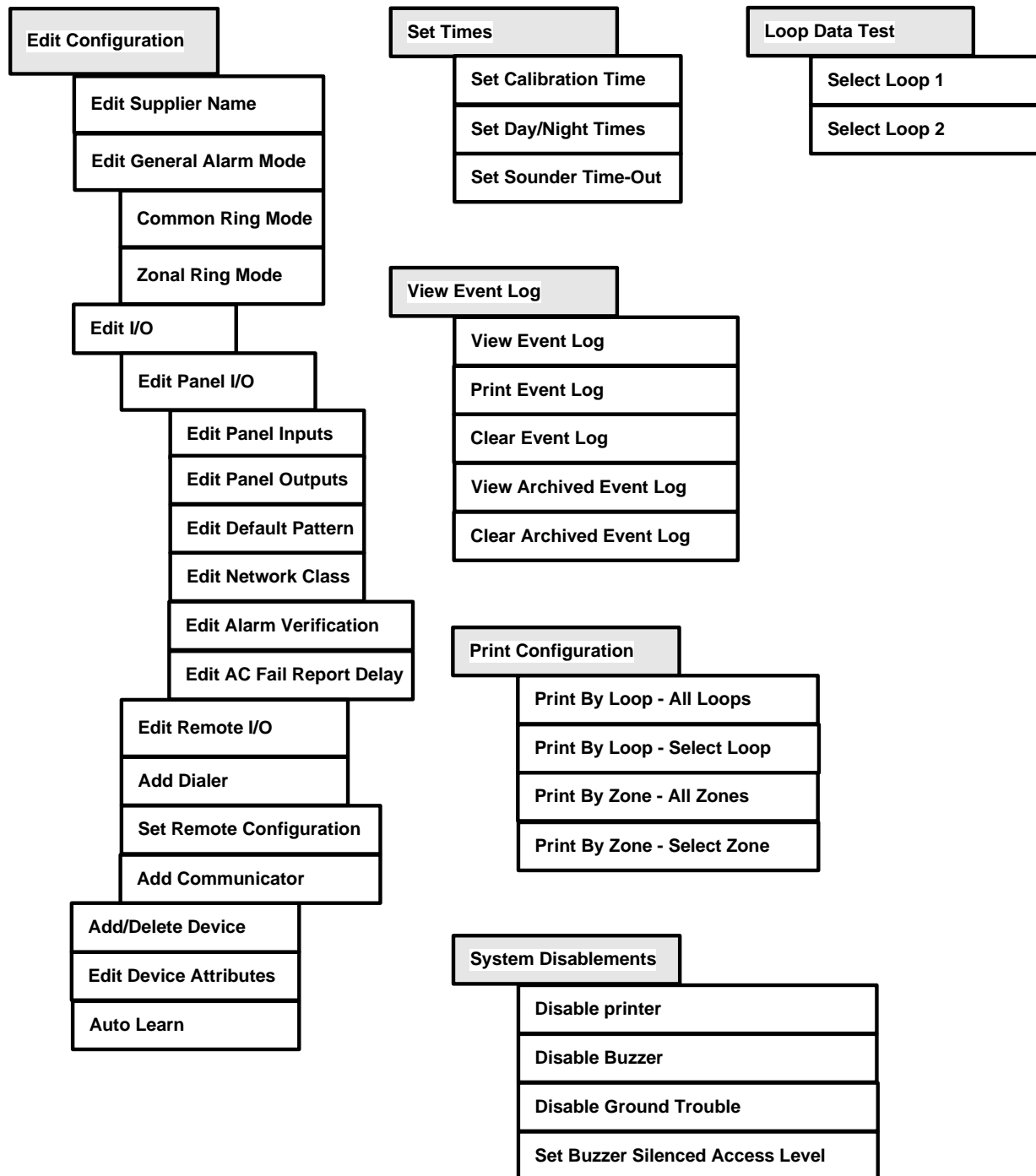

Front-Panel Controls

Access Level 2 operates the following front-panel button-controls:

- Alarm Silence
- Re-sound Alarm
- Reset
- Fire Drill
- Programmable Function

Obtain Access level 2 with the menu-password or with the Enable Access key.

Reference “Section 2, Overview” for a summary of these controls and “Appendix E, Operating Instructions” for detailed functional descriptions.

Alarm Silence

The Alarm Silence button silences the internal buzzer as well as sounders connected to the Elite-RS Panel.

CAUTION!



Pressing the Alarm Silence button silences sounders on the entire network.

Press the Panel Sounder Silence button to silence the internal buzzer without silencing sounders on the entire network.

Re-Sound Alarm

The Re-Sound Alarm button re-sounds the alarm following a silence condition initiated by the Panel Sounder Silence or Alarm Silence command.

Reset

The Reset button clears latching inputs on the control panel. Latching inputs remain active after correcting the cause of the input event. Perform a reset to clear latching inputs on the control panel caused by supervisory, trouble, pre-alarm and fire signals. Non-latching inputs do not require reset. Non-latching inputs clear after correcting the cause of the input condition.

Fire Drill

The Fire drill button initiates a fire drill on the control panel. Cancel the fire drill by pressing the Fire Drill button while in Access Level 2. The Fire Drill button can also be configured for specific functions with eSP Discovery.

Programmable Function

The Programmable Function button is disabled as a default condition, but can be configured to perform specific functions while in Access Level 3, eSP Discovery or Loop Explorer. Operate the Programmable Function button in Access Level 2 of the Elite-RS Panel menu.

Section 5

Maintenance and Repair

This section provides procedures to maintain and repair the Elite-RS Panel.

Reference Appendix B, "Equipment List" for component-part-numbers described in this section.

Maintenance

Perform the following procedures to maintain operation of the Elite-RS Panel.

Inspecting Batteries

Inspect the standby-batteries annually to determine the connection integrity to the power supply and to confirm the voltage capacity available for operating the Elite-RS Panel during power failures.

Replacing Standby-Batteries

Replace standby-batteries when the service period reaches 3 to 5 years. Specify replacement batteries that are sealed-lead-acid and that are UL recognized.

Removing the Standby-Batteries

To remove the existing standby-batteries:

- 1 Disconnect the jumper-cable connection between Battery 1 and Battery 2.
- 2 Disconnect the red-cable from the positive Terminal of Battery 1.
- 3 Disconnect the black-cable from the negative Terminal of Battery 2.
- 4 Remove Battery 1 and Battery 2 from the bottom of the Elite-RS cabinet.
- 5 Re-cycle Battery 1 and Battery 2 according to the manufacturer procedures provided in the packaging of the batteries.

Installing the Standby-Batteries

To install the replacement standby-batteries:

- 1 Place standby-batteries at the bottom of the Elite-RS Panel cabinet.
- 2 Connect the black-cable to the negative terminal of Battery 2.
- 3 Connect the red-cable to the positive terminal of Battery 1.
- 4 Connect the jumper-cable from the negative terminal of Battery 1 to the positive terminal of Battery 2.
- 5 Mark a “placed into service date” on Battery 1 and Battery 2.

Reference Section 3, Installation for more information describing the standby battery installation process.

The figure below illustrates the connection required for installing replacement standby-batteries in the Elite-RS Panel:

Figure 5-1

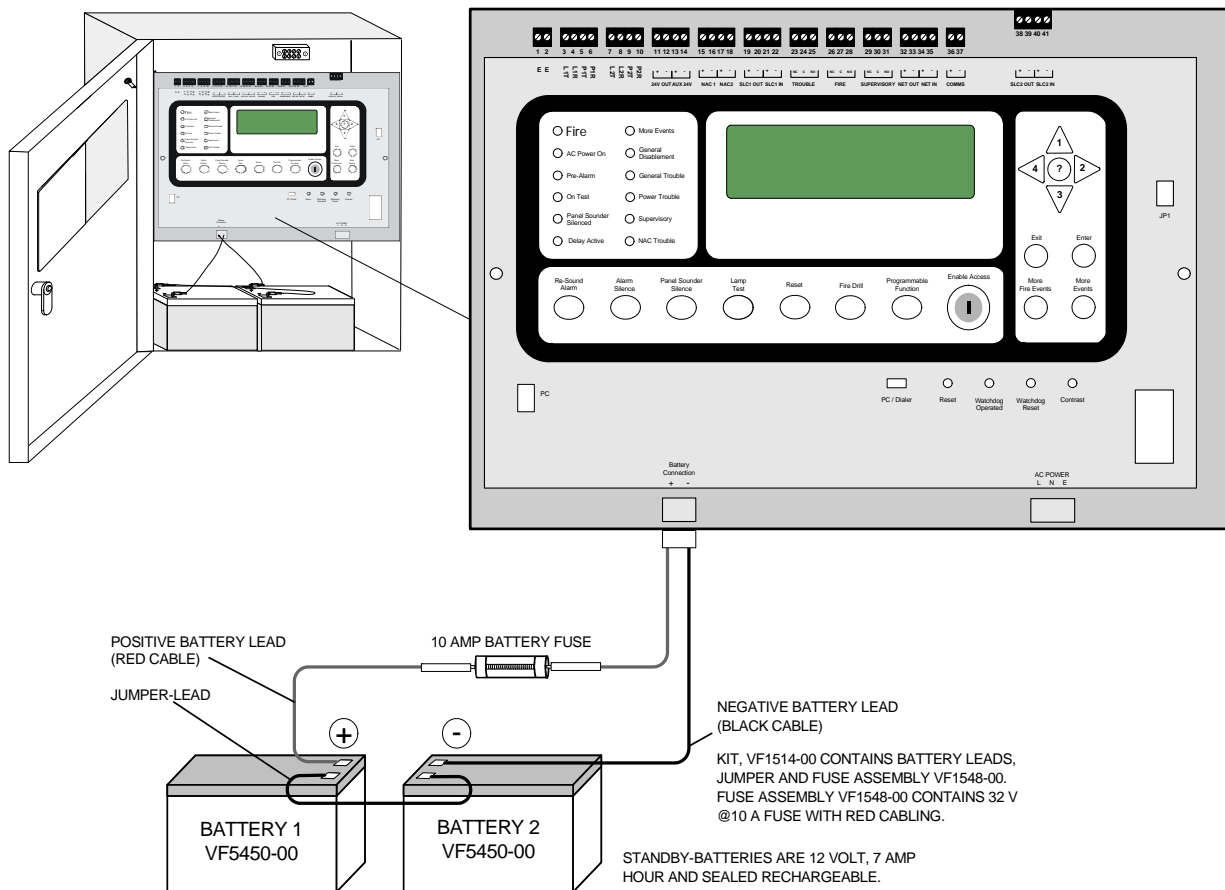

The series connection illustrated above provides the 24 volt standby voltage required by the Elite-RS Panel. Do not connect the two batteries in parallel. A parallel connection will not provide the 24 volts required for operating the Elite-RS Panel in a standby condition.

Replacing Fuses

A 10 Amp battery fuse and a 3 Amp power-supply fuse are provided to protect the Elite-RS Panel against circuit overloads. During the life of the product it may be necessary to replace one or both of the fuses to restore operation to the Elite-RS Panel.

Replace a fuse only after replacing the components responsible for causing the fuse failure. Fuse failure is not a condition caused by the fuse. Diagnose and replace components in the fuse-circuit before replacing the fuse and operating the Elite-RS Panel.

10 Amp Battery Fuse

Replace the 10 Amp battery-fuse by removing the fuse, the battery wiring and the standby-batteries.

Specify kit VF1548-00 to replace the red-cable containing the 10 Amp fuse or specify battery-lead-kit VF1514-00 to replace the red-cable containing the 10 Amp fuse, the jumper-cable and the black-cable.

Replace the 3 Amp Power-Supply Fuse by removing it from the housing contained on the circuit board of the power supply. Install the replacement fuse in the housing and then test the power supply to determine that it operates.

Removing the 10 Amp Battery-Fuse

To remove the fuse:

- 1 Remove the battery-connector from the Battery Connection on the front-panel of the Elite-RS.
- 2 Disconnect the jumper-cable connection between Battery 1 and Battery 2.
- 3 Disconnect the red-cable from the positive terminal of Battery 1.
- 4 Disconnect the black-cable from the negative terminal of Battery 2.
- 5 Dispose the battery-leads described in steps 1 through 3 above.

Installing the 10 Amp Battery-Fuse

To install the new 10 Amp Battery-Fuse:

- 1 Connect the jumper-lead from the negative terminal of Battery 1 to the positive terminal of Battery 2.
- 2 Connect the red-cable to the positive terminal of Battery 1.
- 3 Connect the black-lead to the negative terminal of Battery 2.
- 4 Connect the battery-connector to the Battery Connection on the front-panel of the Elite-RS.
- 5 Determine that trouble conditions are not reported by the Elite-RS Panel following the fuse replacement. This step will confirm if the installation was performed correctly.

3 Amp Power-Supply Fuse

The 3 Amp fuse located on the circuit board of the power supply. Remove this fuse and install a replacement by following the procedures described below.

Removing the Fuse

To remove the fuse:

- 1 Turn off AC power to the control panel at the source.

WARNING!



This is a high voltage circuit area. An electrical shock hazard exists in this area when the control panel is operating. Do not remove the fuse while the control panel is powered. Disconnect AC power at the source before attempting to remove the 3 Amp fuse.

- 2 Remove the AC Power terminal-connector from the connection at the lower-front of the control panel.
- 3 Locate the housing containing the 3 Amp fuse.

The figure below illustrates the location of the 3 Amp fuse on the power supply of the Main Board.

Figure 5-2

3 Amp Fuse Location

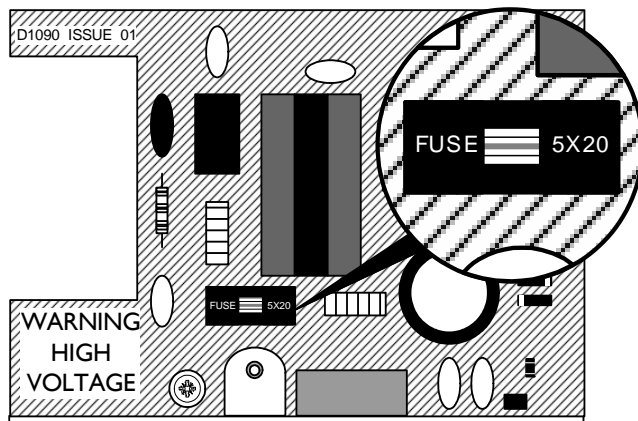

- 4 Remove the upper-half of the fuse-housing with long-nose-pliers.
- 5 Remove the fuse from the upper-half of the fuse-housing.

Installing the Replacement Fuse

To install the replacement fuse:

- 1 Insert the fuse in the upper-housing.
- 2 Center the position of the fuse in the upper-housing.
- 3 Press the upper-housing on the lower-housing until the halves snap together.
- 4 Restore AC power to the power supply.
- 5 Verify that the Elite-RS Panel completes the booting process to confirm that the Power Supply is operating correctly.

Removing Cabinet Components

Remove cabinet components of the Elite-RS to prepare for the mounting process.

To prepare the Elite-RS Panel for mounting:

- 1 Turn the key in the cabinet-door-lock to the right to unlock and open the cabinet-door of the Elite-RS.

Figure 4-3
Unlocking and Opening The Cabinet-Door

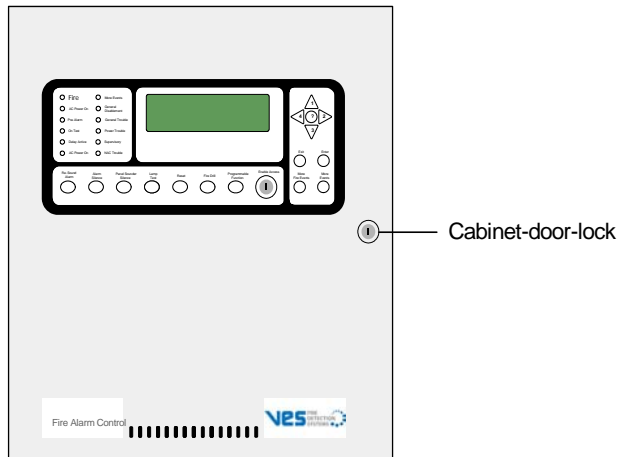

- 2 Remove the upper and lower hinge-pins to remove the cabinet-door.

Figure 4-4
Removing Upper and Lower Hinge-Pins

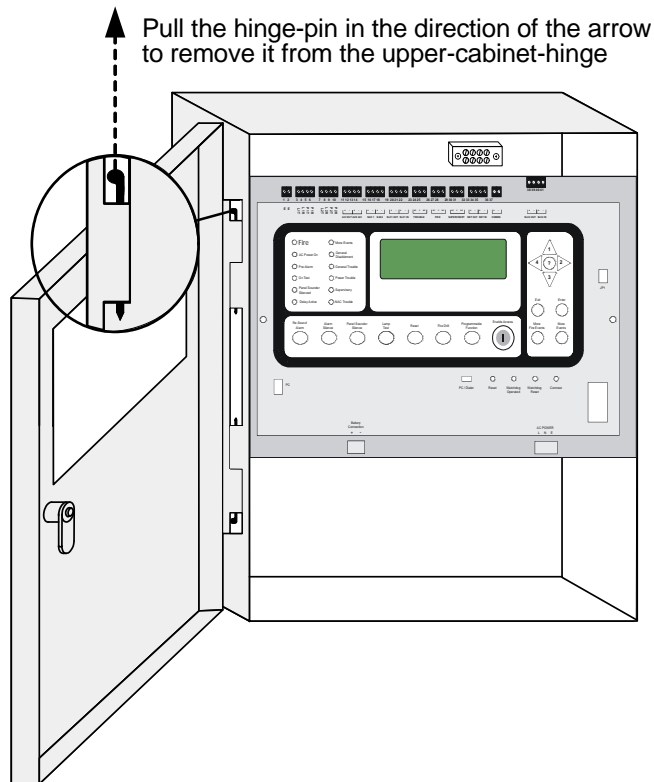

To remove hinge-pins from the cabinet:

- 1 Pull the head of the upper-hinge-pin away from the hinge-assembly using needle-nose-pliers.
- 2 Brace the top-corner of the cabinet-door to maintain alignment with the lower-hinge.
- 3 Pull the head of the lower-hinge-pin away from the hinge-assembly using needle-nose-pliers.

- 3 Remove the cabinet-door from the Elite-RS.

Figure 4-5
Removing the Cabinet-Door

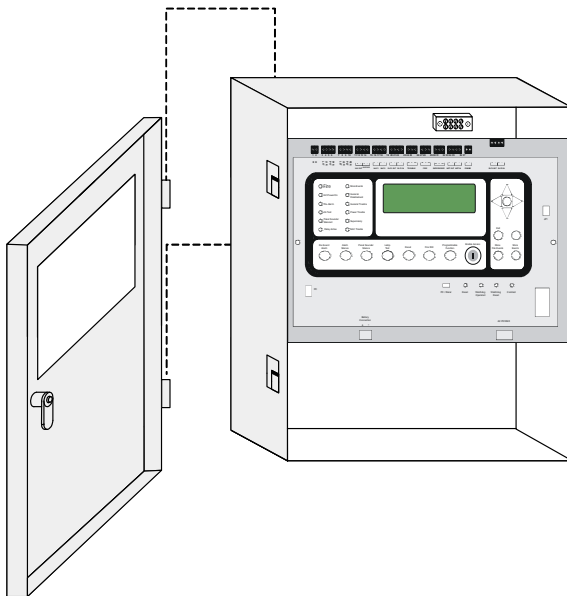

- 4 Remove the terminal-connector from the AC Power socket.

Figure 4-6
Removing the AC Power Connector

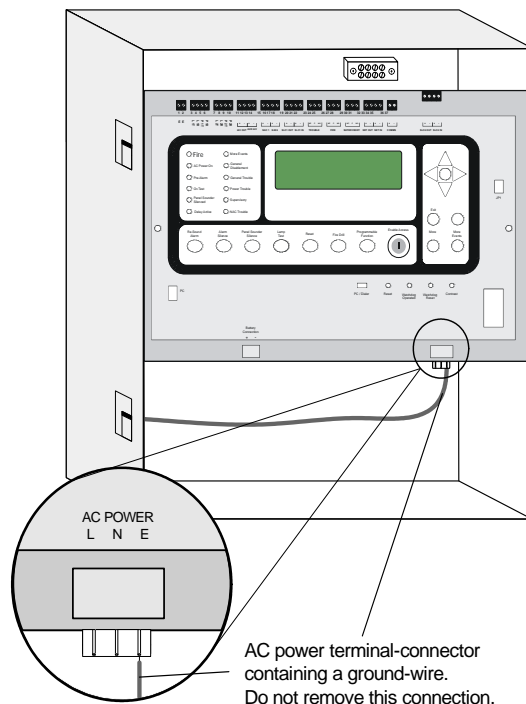

The AC power terminal-connector remains in the cabinet during the mounting process. Disconnect it from the control panel and place it on the bottom of the cabinet. Cover the terminal-connector to prevent debris from contaminating it during the mounting process.

The AC power terminal-connector contains a ground-wire that terminates on the cabinet-wall. The ground-wire is secured to the cabinet-wall with a lock-washer and nut combination. Do not remove this connection during the installation process.

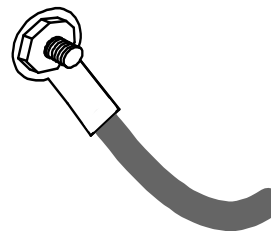

- Remove the retaining screw from the front-panel of the Elite-RS cabinet.

Figure 4-7
Retaining Screw

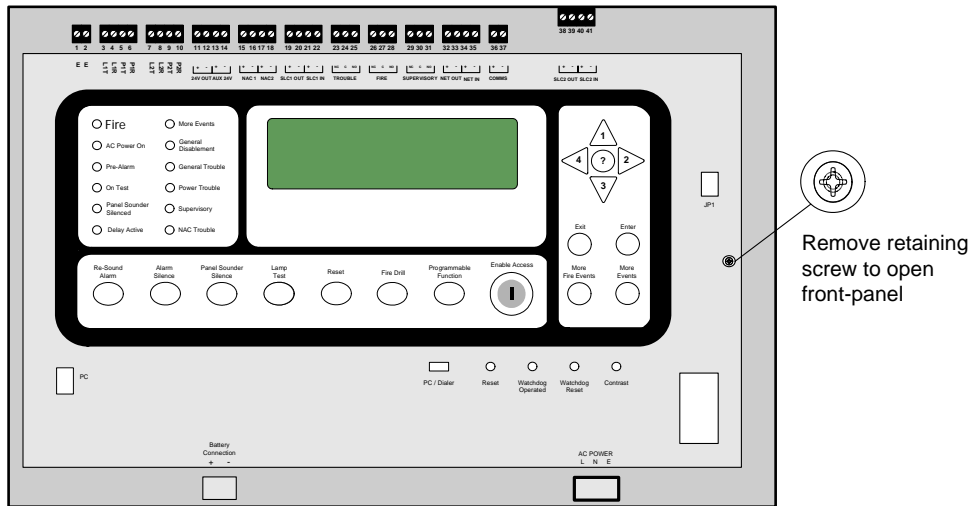

- Open the front-panel of the Elite-RS cabinet.
- Remove the hinge-pins from the front-panel.

Figure 4-8
Removing the Front-Panel

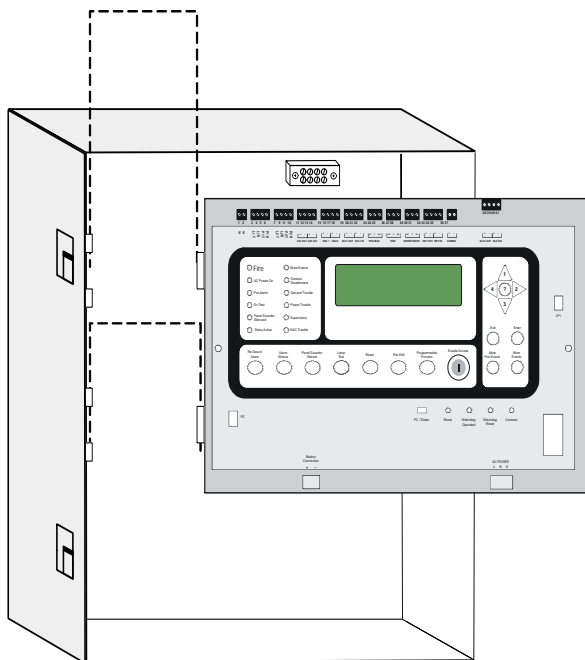

To remove hinge-pins from the front-panel:

- Pull the head of the upper-hinge-pin away from the hinge-assembly using needle-nose-pliers.
- Brace the top-corner of the front-panel to maintain alignment with the lower-hinge.
- Pull the head of the lower-hinge-pin away from the hinge-assembly using needle-nose-pliers.
- Remove the front-panel from the cabinet.

Place the front-panel button-side-down on a clean, dry and uncluttered-surface. Do not place the front-panel down on the component side.

This page intentionally left blank.

Appendix A Specifications

This appendix provides electrical and environmental specifications for the Elite-RS Panel.

Electrical

The electrical specifications provided for Standby and Alarm Current are typical values.

Standby and Alarm Current

Loops	Standby	Alarm (mA)	Description
1	160 mA @ 120 VAC	220 mA @ 120 VAC	Line current for standby and alarm when battery current is less than 30 mA.
	200 mA @ 24 VDC	220 mA @ 24 VDC	Battery current for standby and alarm when a power failure condition occurs on the AC line.
2	200 mA @ 120 VAC	250 mA @ 120 VAC	Line current for standby and alarm when battery current is less than 30 mA.
	270 mA @ 24 VDC	290 mA @ 24 VDC	Battery current for standby and alarm when a power failure condition occurs on the AC line.

Earth Fault Indication

A ground fault indication occurs on the Elite-RS Panel when a minimum of 30K Ohms exists between earth-ground and either DC RTN or +24 VDC of the power-supply.

SLC Ratings

Terminal	Connection	Rating
19	Loop 1 (+ IN)	32 VDC @ 250 mA
20	Loop 1 (- IN)	
21	Loop 1 (+ OUT)	32 VDC @ 250 mA
22	Loop 1 (- OUT)	
38	Loop 2 (+ OUT)	32 VDC @ 250 mA
39	Loop 2 (- OUT)	
40	Loop 2 (+ IN)	32 VDC @ 250 mA
41	Loop 2 (- IN)	

SLC Cabling

The Elite-RS Panel requires the following wire gage and length when connecting Class A and B SLC loops:

Wire Gage	Wire Length
18 AWG	1950 Feet
16 AWG	3100 Feet
14 AWG	5,000 Feet

Programmable Relay Contacts

Terminal	Connection	Rating
23	Trouble (NC), Not Supervised	30 VDC @ 1A
24	Trouble (C), Not Supervised	30 VDC @ 1A
25	Trouble (NO), Not Supervised	30 VDC @ 1A
26	Fire (NC), Not Supervised	30 VDC @ 1A
27	Fire (C), Not Supervised	30 VDC @ 1A
28	Fire (NO), Not Supervised	30 VDC @ 1A
29	Supervisory (NC), Not Supervised	30 VDC @ 1A
30	Supervisory (C) Not Supervised	30 VDC @ 1A
31	Supervisory (NO) Not Supervised	30 VDC @ 1A

NAC Outputs

Terminal	Connection	Rating
15	NAC 1 (+)	Regulated: 24 VDC @ 1.6 A continuous DC or 900 mA pulsed DC Special Application: 24 VDC @ 2.3 A continuous with the combined current of NAC 1 and NAC 2 not to exceed 3.1 A
16	NAC 1 (-)	
17	NAC 2 (+)	Regulated: 24 VDC @ 1.6 A continuous DC or 900 mA pulsed DC Special Application: 24 VDC @ 2.3 A continuous with the combined current of NAC 1 and NAC 2 not to exceed 3.1 A
18	NAC 2 (-)	

Reference Appendix B, “Equipment List” for NAC devices that are authorized for use with the Elite-RS Panel.

NAC outputs of the Elite-RS Panel can be operated in regulated or special application modes.

Regulated Outputs

NAC outputs of the Elite-RS Panel operate in a regulated mode when conforming to specific levels of continuous or pulsed DC. NAC outputs meet requirements for regulated levels when the output current does not exceed the constraints described below:

Continuous Current

Continuous DC currents cannot exceed 1.6 A from either NAC output when operating in a regulated output mode:

Regulated continuous DC output = 1.6 A_{NAC 1} + 1.6 A_{NAC 2} = 3.2 A total

Pulsed Current

Pulsed DC currents cannot exceed 900 mA from either NAC output when operating in a regulated output mode:

Regulated pulsed DC output = 900 mA_{NAC 1} + 900 mA_{NAC 2} = 1.8 A total

Synchronization

Synchronize the regulated output of NAC 1 and NAC 2 using UL listed and compatible synchronization modules. Connect End-Of-Line-Device VF1539-00 to the output of each Synchronization Module installed.

Reference Appendix B, Equipment List for more information about NAC synchronization on the Elite-RS Panel.

Special Application Output

NAC outputs of the Elite-RS Panel operate in a special application mode when conforming to specific levels of continuous DC. NAC outputs meet requirements for special application levels when the output current does not exceed the 2.3 A of NAC 1 or NAC 2 with the combined current of NAC 1 and NAC 2 not to exceed 3.1 A.

Synchronization

The Elite-RS Panel provides internal device synchronization between the outputs of NAC 1 and NAC 2 when operating NAC devices from Gentex, Amseco, System Sensor or Wheelock.

External synchronization modules must not be used on the NAC outputs when operating in the special application mode.

Reference Appendix B, Equipment List for more information about NAC synchronization on the Elite-RS Panel.

Phone Line Connections

Terminal	Connection	Description
3	L1T	TELCO Line 1 Tip
4	L1R	TELCO Line 1 Ring
5	P1T	TELCO Phone 1 Tip
6	P1R	TELCO Phone 1 Ring
7	L2T	TELCO Line 2 Tip
8	L2R	TELCO Line 2 Ring
9	P2T	TELCO Phone 2 Tip
10	P2R	TELCO Phone 2 Ring

RS485 Serial Bus

Terminal	Connection	Rating
36	COMMS (+)	(+) Data 3.3 VDC @ 30 mA
37	COMMS (-)	(-) Data

eNET Terminals

Terminal	Connection	Rating
32	NET OUT (+)	(+) Data 3.3 VDC @ 30 mA
33	NET OUT (-)	(-) Data
34	NET IN (+)	(+) Data 3.3 VDC @ 30 mA
35	NET IN (-)	(-) Data

24 V OUT

Terminal	Connection	Rating
11	24 V OUT (+)	Regulated 24 VDC @ 360 mA
12	24 V OUT (-)	

The 24 V OUT connection is a common output and provides a regulated 24 VDC output.

Auxiliary 24 VDC

Terminal	Connection	Rating
13	AUX 24V (+)	Regulated 24 VDC @ 360 mA
14	AUX 24V (-)	

The AUX 24 VDC connection is a common output and provides a regulated 24 VDC output.

AC Line Connection

Terminal	Description	Voltage	Current
L	AC line	120 VAC, 50/60Hz	2.1 A
		240 VAC, 50/60Hz	1.1 A
N	AC neutral		
G	Earth ground		

Power Supply

Fuse	3A, 250VAC, SLOW-BLOW, 5 x 20mm
Input (Supervised)	120 or 240 VAC 50/60Hz
Output Voltage	24 VDC Regulated
Output Current	0 - 4 Amps
Charge Current	Fast charge: 1.25 A Trickle charge: 1.25 A (voltage limited)
Battery-Charging Type	Two 12 VDC SLA standby batteries wired in series
Transfer Voltage	120 VAC transfer @ 75 VAC 240 VAC transfer @ 160 VAC

The specifications above pertain to terminations of the standby-battery at the Battery Connection of the Elite-RS Panel.

Cabling

The following specifications identify the range of acceptable wire gages for field wiring, battery and power connections:

Field Wiring

Designation	Terminal	Wire Range	Description
E, E	1 and 2	14 - 26 AWG	Earth ground
L1T	3	14 - 26 AWG	Line 1 phone tip
L1R	4	14 - 26 AWG	Line 1 phone ring
P1T	5	14 - 26 AWG	Phone line 1 tip for telephone operation. Drops connection during alarm conditions to allow TELCO reporting on L1T.
P1R	6	14 - 26 AWG	Phone line 1 ring for telephone operation. Drops connection during alarm conditions to allow TELCO monitoring on L1R.
L2T	7	14 - 26 AWG	Line 2 phone tip
L2R	8	14 - 26 AWG	Line 2 phone ring
P2T	9	14 - 26 AWG	Phone line 2 tip for telephone operation. Drops connection during alarm conditions to allow TELCO reporting on L2T.
P2R	10	14 - 26 AWG	Phone line 2 ring for telephone operation. Drops connection during alarm conditions to allow TELCO monitoring on L2R.
24V OUT	11 and 12	14 - 26 AWG	Terminal connections for the 24 volt output
AUX 24V	13 and 14	14 - 26 AWG	Terminal connections for the auxiliary 24 volt output
NAC1	15 and 16	14 - 26 AWG	Terminal connections for the NAC 1 circuit.
NAC2	17 and 18	14 - 26 AWG	Terminal connections for the NAC 2 circuit.
SLC1 IN	19 and 20	14 - 26 AWG	Terminal connections for the "IN" of SLC loop 1.
SLC1 OUT	21 and 22	14 - 26 AWG	Terminal connections for the "OUT" of SLC loop 1.
TROUBLE	23, 24 and 25	14 - 26 AWG	Normally closed (NC) and normally open (NO) contacts of the trouble circuit.
FIRE	26, 27 and 28	14 - 26 AWG	Normally closed (NC) and normally open (NO) contacts of the fire circuit.
SUPERVISORY	29, 30 and 31	14 - 26 AWG	Normally closed (NC) and normally open (NO) contacts of the supervisory circuit.

Designation	Terminal	Wire Range	Description
NET OUT	32 and 33	14 - 26 AWG	Terminals connections for the eNET "OUT" network
NET IN	34 and 35	14 - 26 AWG	Terminals connections for the eNET "IN" network
COMMS	36 and 37	14 - 26 AWG	Terminal connections for RS485 serial communication
SLC2 OUT	38 and 39	14 - 26 AWG	Terminal connections for the "OUT" of SLC loop 2.
SLC2 IN	40 and 41	14 - 26 AWG	Terminal connections for the "IN" of SLC loop 2.

Battery and Power

Designation	Terminal	Wire Range	Description
Battery Connection	+	12 - 24 AWG	Positive connection for the Standby-batteries
	-	12 - 24 AWG	Negative connection for the Standby-batteries
AC Power	L	12 - 24 AWG	Line connection
	N	12 - 24 AWG	Neutral connection
	E	12 - 24 AWG	Ground connection

Cabling Construction

Material	All field wiring should be installed using fire rated cables according to the NFPA.
Cross Sectional Size	The cross sectional size of the SLC cables should be determined based on length and the number of devices in use. Connect SLC cabling using a minimum of 1mm cross sectional area.

Operating Environment

Low Temperature	32 +/- 3°F (0 +/- 2°C)	Dry indoor use only
High Temperature	120+/- 3°F (49 +/- 2°C)	Dry indoor use only
Relative Humidity	93% +/- 2% @ 90 +/- 3°F (32 +/- 2°C)	This device functions in an atmosphere of relative humidity up to 93 percent, non-condensing.

Physical Specifications

Dimensions	18.50"H X 14"W X 4.25"D
Mounting	0.25" Maximum screw diameter

This page intentionally left blank.

Appendix B

Equipment List

This appendix lists models and supporting equipment of the Elite-RS Panel. *All models provided in this appendix are affected by the Contact ID restrictions described in Section 2, “Overview” and Section 3, “Installation”.*

Elite-RS Panels

The following models are provided for the Elite-RS A-Series Panel:

Models	Features	Color
VF0850-10	1 Loop Panel, No Communication	Red
VF0850-40	1 Loop Panel, No Communication	Gray
VF0870-10	1 Loop Panel, Non-Expandable, No Communication	Red
VF0870-40	1 Loop Panel, Non-Expandable, No Communication	Gray
VF0851-10	1 Loop Panel, Media Gateway	Red
VF0851-40	1 Loop Panel, Media Gateway	Gray
VF0871-10	1 Loop Panel, Non-Expandable, Media Gateway	Red
VF0871-40	1 Loop Panel, Non-Expandable, Media Gateway	Gray
VF0852-10	1 Loop Panel, Network Interface Card (NIC)	Red
VF0852-40	1 Loop Panel, Network Interface Card (NIC)	Gray
VF0872-10	1 Loop Panel, Non-Expandable, Network Interface Card (NIC)	Red
VF0872-40	1 Loop Panel, Non-Expandable, Network Interface Card (NIC)	Gray
VF0854-10	1 Loop Panel, Modem-DACT Ethernet	Red
VF0854-40	1 Loop Panel, Modem-DACT Ethernet	Gray
VF0874-10	1 Loop Panel, Non-Expandable, Modem-DACT Ethernet	Red
VF0874-40	1 Loop Panel, Non-Expandable, Modem-DACT Ethernet	Gray
VF0855-10	1 Loop Panel, eNet Interface	Red
VF0855-40	1 Loop Panel, eNet Interface	Gray
VF0856-10	1 Loop Panel, Integrated Dialer	Red
VF0856-40	1 Loop Panel, Integrated Dialer	Gray
VF0876-10	1 Loop Panel, Non-Expandable, Integrated Dialer	Red
VF0876-40	1 Loop Panel, Non-Expandable, Integrated Dialer	Gray
VF0857-10	1 Loop Panel, eNet Interface & Integrated Dialer	Red
VF0857-40	1 Loop Panel, eNet Interface & Integrated Dialer	Gray

Models	Features	Color
VF0860-10	2 Loop Panel, No Communication, Loop Expansion Module	Red
VF0860-40	2 Loop Panel, No Communication, Loop Expansion Module	Gray
VF0861-10	2 Loop Panel, Media Gateway, Loop Expansion Module	Red
VF0861-40	2 Loop Panel, Media Gateway, Loop Expansion Module	Gray
VF0862-10	2 Loop Panel, Network Interface Card (NIC), Loop Expansion Module	Red
VF0862-40	2 Loop Panel, Network Interface Card (NIC), Loop Expansion Module	Gray
VF0864-10	2 Loop Panel, Modem-DACT Ethernet	Red
VF0864-40	2 Loop Panel, Modem-DACT Ethernet	Gray
VF0865-10	2 Loop Panel, eNet Interface, Loop Expansion Module	Red
VF0865-40	2 Loop Panel, eNet Interface, Loop Expansion Module	Gray
VF0866-10	2 Loop Panel, Integrated Dialer, Loop Expansion Module	Red
VF0866-40	2 Loop Panel, Integrated Dialer, Loop Expansion Module	Gray
VF0867-10	2 Loop Panel, eNet Interface & Integrated Dialer, Loop Expansion Module	Red
VF0867-40	2 Loop Panel, eNet Interface & Integrated Dialer, Loop Expansion Module	Gray

Loop Devices and Accessories

The following A-Series loop devices and accessories are authorized for use with the Elite-RS Panel:

VES Models		Loop Devices
VF4990-00		Multi-Flex Sounder Base Analog Addressable
VF4991-00		2-Wire Analog Addressable Photoelectric Duct Smoke Detector
VF4992-00		4-Wire Analog Addressable Photoelectric Duct Smoke Detector
VES Models	Apollo Models	Loop Devices
VF5630-00	45681-210	95A Mounting Base 4"
VF5634-00	45681-211	95A Isolator Base-SC
VF5631-00	45681-225	95A Mounting Base 6"
VF5636-00	45681-234	95A Low Profile Relay Base 6"
VF5635-00	45681-242	95A Relay Base 4"
VF5632-00	45681-250	Base 6" E-Z Fit
VF5633-00	45681-321	95A Base 20D Isolator

VES Models	Apollo Models	Loop Devices
VF5604-00	55000-266	95A Loop Powered Beam Detector
VF5605-00	55000-750	95A Isolator
VF5664-00	55000-790	95A Dual Priority Switch Monitor Module
VF5662-00	55000-805	95A Switch Monitor Module
VF5663-00	55000-806	95A Priority Switch Monitor Module
VF5665-00	55000-820	95A Switch Monitor Input/Output Module
VF5666-00	55000-825	95A Sounder Control Module
VF5660-00	55000-830	95A Mini Priority Switch Monitor Module
VF5661-00	55000-831	95A Mini Switch Monitor Module
VF5667-00	55000-863	95A Relay Output Module
VF5668-00	55000-450	95A Heat Detector
VF5669-00	55000-550	Ion Smoke Detector
VF5670-00	55000-650	Optical Smoke Detector
VF5671-00	55000-886	Multi Sensor
VF5602-00	58000-450	Discovery Heat Detector
VF5600-00	58000-550	Discovery Ionization Smoke Detector
VF5601-00	58000-650	Discovery Photo-Electric Smoke Detector
VF5603-00	58000-750	Discovery Multi-sensor Detector
VF5608-00	55000-765	Mini Switch Monitor
VF5609-00	53832-070	Mini Disc Remote Indicator
VF5020-00		Remote Test Station for Duct Detectors – Alarm LED
VF5021-00		Remote Test Station for Duct Detectors – Alarm LED w/ Reset Button
VF5023-00		Remote Test Station for Duct Detectors – Alarm LED w/ Reset Key-Switch
VF3033-00	56000-001	Manual Pull-Station, Single Action, Addressable
VF3034-00	56000-002	Manual Pull-Station, Dual Action, Addressable

Replacement Parts

The following VES replacement parts are provided for the Elite-RS Panel:

Models	Description
VF1054-00	Loop Expansion Module
VF1153-00	Modem-DACT Ethernet
VF1150-00	Media Gateway
VF1151-00	Network Interface Card (NIC)
VF1170-00	eNet Interface
VF1607-00	Main Board without Integrated Dialer
VF1609-00	Main Board with Integrated Dialer
VF1507-00	Panel Key Lock Set
VF1508-00	Panel Bonding Strap
VF1509-00	Panel Grounding Block
VF1511-00	Panel Standoff Kit
VF1513-00	Panel Main AC Input Fuse
VF1514-00	Battery Leads & Jumper
VF3532-00	Elite-RS Installation Manual
VF3534-00	Elite-RS Door Label
VF3535-00	Operating Instructions
VF1517-00	Resistor Kit (6) 10K Ohm
VF1544-00	EOL Resistor 10K
VF1518-00	Resistor Kit (8) Zero Ohm
VF1539-00	EOLD for Synchronization Module outputs only
VF1520-00	EOLD for municipal boxes
VF5450-00	Standby-Battery, 12 Volt, 7 AH, two per cabinet
VF5455-00	Battery Cabinet
VF1171-00	16 Channel I/O Interface

Models	Description
VF13XX-YYY	The eMatrix is a graphical annunciator. Configure features of this device to assign numerical values to part number variables XX-YYY. Specify model number VF13XX-YYY for the base version of this unit. Reference eMatrix Installation Manual, VF3513-00 for configuration features required for your application.
VF1172-10	eView, annunciator, red
VF1172-40	eView, annunciator, gray
VF1173-10	eView, flush mount kit, red
VF1173-40	eView, flush mount kit, gray
VF1071-40	Trim ring for the Elite-RS Panel, gray
VF1071-10	Trim ring for the Elite-RS Panel, red

Notification Appliances

Notification Appliances furnished in this manual operate with the Elite-RS Panel in a special application or regulated mode. The Elite-RS Panel supports the simultaneous operation of regulated and special application outputs between NAC 1 and NAC 2.

The Elite-RS Panel does not support the simultaneous operation of regulated and special application outputs on the same NAC channel.

The Elite-RS Panel supports regulated outputs when operating:

- Gentex NAC devices without synchronization modules
- System Sensor NAC devices with synchronization modules
- Wheelock NAC devices with synchronization modules
- Amseco NAC devices with synchronization modules

The Elite-RS Panel supports special application outputs when operating:

- Gentex NAC devices without synchronization modules
- System Sensor NAC devices without synchronization modules
- Wheelock NAC devices without synchronization modules
- Amseco NAC devices without synchronization modules

Synchronization

NAC channels 1 and 2 of the Elite-RS Panel provide single and dual circuit synchronization. Single circuit synchronization provides synchronized NAC outputs on one channel of the Elite-RS Panel. Dual circuit synchronization provides synchronized NAC outputs on two channels of the Elite-RS Panel.

NAC synchronization can be performed on individual Elite-RS Panels.

NAC synchronization cannot be performed on between multiple Elite-RS Panels.

Configuring NAC Outputs

Settings are provided in eSP Discovery and Loop Explorer for controlling the NAC outputs of the Elite-RS Panel. Selections are available in these utilities for providing outputs with synchronization or various forms of constant power. Settings are also provided to allow the Alarm Silence button to operate on the front-panel in various modes.

NAC channels of the Elite-RS Panel can be configured as independent outputs as long as the same manufacturer types are used when operating synchronized outputs.

Strobe operations are disabled as default functions on the Elite-RS Panel. Settings are available to enable the operation of sounders and strobes when operating NAC channels in the constant power mode.

Review the settings described below to configure each NAC output for operation: .

Output Options	<p>General Alarm and Emergency are selected as default conditions. Alternative output options for this field include Auxiliary Output, Pre Alarm Output, Supervisory Alarm, Trouble and Security Output.</p> <p><i>Do not select the General Alarm option if the NAC channel is to be controlled by cause and effect programming.</i></p>
Strobe	<p>Strobe Output is not selected for operation as a default condition. Selecting this field allows the user to define which synchronization protocol to be used.</p>
NAC Aux 24 DC	<p>When the Strobe option above is not selected, Off is selected as the default operating condition. Options for this output are continuous constant power, door holder continuous power and resettable constant power. Continuous constant power provides a voltage output identical to Aux 24 VDC. Door holder continuous power drops out during fire alarm conditions or when an AC fail event occurs. Resettable constant power drops out between four and five seconds after the reset of the control panel.</p>
Alarm Silence	<p>Each NAC circuit is configurable in reaction to the Alarm Silence button on the front-panel of the Elite-RS. Edit properties of the NAC channel in Loop Explorer or eSP Discovery. Select the box for Silencing if NAC silencing is required on this channel. If Internal Synchronization Protocols are in use, an option is also available to Silence the strobe.</p> <p><i>Failure to check the Strobe Silence box will cause horns to be silenced with continued operation of the strobe.</i></p>

Regulated NAC Outputs

NAC outputs of the Elite-RS Panel operate in a regulated mode when conforming to specific levels of continuous or pulsed DC. NAC outputs meet requirements for regulated levels when the output current does not exceed the constraints described below:

Regulated Continuous Output Current

Continuous DC currents cannot exceed 1.6 A from either NAC output when operating in a regulated output mode:

Regulated continuous DC output = 1.6 A_{NAC 1} + 1.6 A_{NAC 2} = 3.2 A total

Regulated Pulsed Output Current

Pulsed DC currents cannot exceed 900 mA from either NAC output when operating in a regulated output mode:

Regulated pulsed DC output = 900 mA_{NAC 1} + 900 mA_{NAC 2} = 1.8 A total

Reference Appendix A, Specifications for operating NAC outputs in the regulated mode.

Synchronization Modules

Synchronize the regulated output of NAC 1 and NAC 2 using UL listed and compatible synchronization modules. Connect End-Of-Line-Device VF1539-00 to the output of each Synchronization Module installed.

Operating the NAC outputs of the Elite-RS Panel in a regulated output mode requires the use of external synchronization-modules when performing synchronization. Notification Appliances and Synchronization Modules are described in the table below for regulated NAC outputs of the Elite-RS Panel:

Manufacturer	Manufacturer Sync Module	VES Sync Module	Manufacturer and VES NAC Device	Maximum NAC Load
System Sensor	MDL (Red) MDLW (White)	VF6012-10 (Red) VF6012-30 (White)	***	0.90 A
Wheelock	SM-24-R DSM-24-R	VF6009-10 (Single) VF6010-10 (Dual)	***	0.90 A
Amseco	SMD10-3A	VF5000-00	***	0.90 A

**** All NAC devices determined to be compatible with the synchronization modules above are compatible for operation with the Elite-RS Panel.*

Special Application NAC Outputs

NAC outputs of the Elite-RS Panel operate in a special application mode when conforming to specific levels of continuous DC. Outputs meet these requirements when NAC currents do not exceed the 2.3 A of NAC 1 or NAC 2 with the combined current of NAC 1 and NAC 2 not to exceed 3.1 A.

Reference Appendix A, Specifications for operating NAC outputs in the special application mode.

Synchronization

The Elite-RS Panel provides internal device synchronization between the outputs of NAC 1 and NAC 2 when operating NAC devices from Gentex, Amseco, System Sensor or Wheelock.

External synchronization modules must not be used on the NAC outputs when operating in the special application mode.

NAC devices from Amseco, Gentex, System Sensor and Wheelock do not require external synchronization modules when operating in the special application mode. The Elite-RS Panel contains an internal synchronization feature that supports these NAC devices.

Amseco Compatible NAC Devices

The following series of Amseco NAC devices are compatible for use on the special application outputs of NAC 1 and 2 when these outputs are configured for “Amseco” synchronization protocol:

Name of Series	Environment	Model Series	Description	Mount
Select-A-Strobe/Chime	Indoor	CM24C	Chime	Ceiling
Select-A-Strobe/Chime	Indoor	SCM24C	Chime Strobe	Ceiling
Select-A-Horn	Indoor/Outdoor	H-1224	Horn	Wall
Select-A-Strobe/Horn	Indoor	SH-1224	Horn Strobe	Wall
Select-A-Strobe/Horn	Outdoor	SH-1224WP	Horn Strobe	Wall
Select-A-Strobe/Horn	Indoor	SH24C-177	Horn Strobe	Wall/Ceiling
Select-A-Strobe/Horn	Indoor	SH24C-3075110	Horn Strobe	Wall/Ceiling
Speaker/Strobe Square	Indoor/Outdoor	SSS-2	Speaker Strobe	Wall
Speaker/Strobe Square	Indoor/Outdoor	SSS-8	Speaker Strobe	Wall
Speaker/Strobe Round	Indoor/Outdoor	SSR-2	Speaker Strobe	Wall/Ceiling
Speaker/Strobe Round	Indoor/Outdoor	SSR-8	Speaker Strobe	Wall/Ceiling
Speaker/Strobe Round	Indoor	SSC-2	Speaker Strobe	Wall/Ceiling
Speaker/Strobe Round	Indoor	SSC-8	Speaker Strobe	Wall/Ceiling
Select-A-Strobe	Indoor	SL-1224	Strobe	Wall
Select-A-Strobe	Indoor/Outdoor	SL-1224-WP	Strobe	Wall
Select-A-Strobe	Indoor	SL24C-3075110	Strobe	Wall/Ceiling
Select-A-Strobe	Indoor	SL24C-177	Strobe	Wall/Ceiling
Bell/Select-A-Strobe	Indoor	SB24	Bell Strobe	Wall/Ceiling
Select-A-Strobe/Chime	Indoor	SCM24W-153075	Chime Strobe	Wall
Select-A-Strobe/Chime	Indoor	SCM24W-75110	Chime Strobe	Wall

Name of Series	Environment	Model Series	Description	Mount
Select-A-Horn	Indoor	H24W	Horn	Wall/Ceiling
Select-A-Strobe/Horn	Indoor	SH24W-1530	Horn Strobe	Wall
Select-A-Strobe/Horn	Indoor	SH24W-75110	Horn Strobe	Wall
Indoor/Outdoor Horn/ Strobe	Indoor/Outdoor	SHB24-75	Horn Strobe	Wall
Speaker/Strobe	Indoor	SSC25-177	Speaker Strobe	Wall/Ceiling
Select-A-Strobe/Speaker	Indoor	SSC25-3075110	Speaker Strobe	Wall/Ceiling
Speaker/Strobe	Indoor	SSC70-177	Speaker Strobe	Wall/Ceiling
Select-A-Strobe/Speaker	Indoor	SSC70-3075110	Speaker Strobe	Wall/Ceiling
Select-A-Strobe/Speaker	Indoor	SFH45-153075	Speaker Strobe	Wall/Ceiling
Select-A-Strobe/Speaker	Indoor	SFH47-75110	Speaker Strobe	Wall/Ceiling
Select-A-Strobe	Indoor	SL24W-1530	Strobe	Wall
Select-A-Strobe	Indoor	SL24W-75110	Strobe	Wall
Indoor/Outdoor Strobe	Indoor/Outdoor	SLB24-75	Strobe	Wall
Select-A-Strobe	Indoor/Outdoor	SB24	Strobe	Wall/Ceiling
Select-A-Strobe/Horn	Indoor	SH24W-153075	Horn Strobe	Wall
Select-A-Strobe	Indoor	SL24W-153075	Strobe	Wall
Select-A-Strobe	Indoor	ASH-2475110R	Horn Strobe	Wall
Select-A-Strobe	Indoor	RSB24-153075	Strobe	Wall/Ceiling
Select-A-Strobe	Indoor	RSD24-153075	Strobe	Wall/Ceiling
Select-A-Strobe	Indoor	RSD24-75110	Strobe	Wall/Ceiling
Select-A-Strobe	Indoor	SA24 SERIES	Strobe	Wall
Select-A-Strobe	Indoor	SAD24-153075	Strobe	Wall/Ceiling
Select-A-Strobe	Indoor	SAD24-75110	Strobe	Wall

Gentex Compatible NAC Devices

The following series of Gentex NAC devices are compatible for use on the special application outputs of NAC 1 and 2 when these outputs are configured for “Gentex” synchronization protocol:

Name of Series	Environment	Model Series	Description	Mount
WSSPK Series	Outdoor	WSSPK24-15/75	Speaker Strobe	Wall
SSPK24WLP Series	Indoor	SSPK24WLP	Speaker Strobe	Wall
SSPKCLP Series	Indoor	SSPK24CLP	Speaker Strobe	Ceiling
Commander4 Series	Indoor	GCC24	Horn Strobe	Ceiling
Commander4 Series	Indoor	GCS24	Strobe	Ceiling
Commander3 Series	Indoor	GEC3-24	Horn Strobe	Wall
Commander3 Series	Indoor	GES3-24	Strobe	Wall
Commander3 Series	Indoor	GEH24	Horn	Wall
Commander2 Series	Indoor	GEC24	Horn Strobe	Wall
Commander2 Series	Indoor	GES24	Strobe	Wall
Commander2 Series	Indoor	GEH24	Horn	Wall
Outdoor Commander Series	Outdoor	WGEC24	Horn Strobe	Wall
Outdoor Commander Series	Outdoor	WGES24	Strobe	Wall
Outdoor Commander Series	Outdoor	GEH24	Horn	Wall
GX91/GX93 Series	Indoor	GX93	Mini Horn	Wall

VES Multiple-Listed Gentex Models

The “XX” shown in VES model numbering denotes product color.

The following VES NAC models are multiple-listed with Gentex and are compatible for use on the special application outputs of NAC 1 and 2 when these outputs are configured for “Gentex” synchronization protocol:

VES Models	Gentex Models	Gentex Part Numbers	Description
VF4000-XX	GEH24-R	904-1205-002	Horn, Wall Red (GEH)
VF4000-XX	GEH24-W	904-1207-002	Horn, Wall White (GEH)
VF4001-XX	GES3-24WR	904-1321-002	Strobe, Wall Red Multi Candela (GES3)
VF4001-XX	GES3-24WW	904-1319-002	Strobe, Wall White Multi Candela (GES3)
VF4002-XX	GEC3-24WR	904-1317-002	Horn/Strobe, Wall Red Multi Candela (GEC3)
VF4002-XX	GEC3-24WW	904-1315-002	Horn/Strobe, Wall White Multi Candela (GEC3)
VF4003-XX	GCS24CR	904-1213-002	Strobe, Ceiling Red Multi Candela (GCS)
VF4003-XX	GCS24CW	904-1215-002	Strobe, Ceiling White Multi Candela (GCS)
VF4004-XX	GCC24CR	904-1209-002	Horn/Strobe, Ceiling Red Multi Candela (GCC)
VF4004-XX	GCC24CW	904-1211-002	Horn/Strobe, Ceiling White Multi Candela (GCC)
VF4007-XX	WGEC24-75WR	904-1217-002	Weatherproof Horn/Strobe (Gentex) Red

System Sensor Compatible NAC Devices

The following series of System Sensor NAC devices are compatible for use on the special application outputs of NAC 1 and 2 when these outputs are configured for “System Sensor” synchronization protocol:

Name of Series	Environment	Model Series	Description	Mount
SpectrAlert Advance	Indoor	SPS	Speaker Strobe	Wall
SpectrAlert Advance	Indoor	SPSC	Speaker Strobe	Ceiling
SpectrAlert Advance	Outdoor	SPS (K)	Speaker Strobe	Wall
SpectrAlert Advance	Outdoor	SPSC (K)	Speaker Strobe	Ceiling
SpectrAlert Advance	Indoor	P2	Horn Strobe, 2-Wire	Wall

Name of Series	Environment	Model Series	Description	Mount
SpectrAlert Advance	Indoor	P4	Horn Strobe, 4-Wire	Wall
SpectrAlert Advance	Indoor	S	Strobe	Wall
SpectrAlert Advance	Indoor	PC2	Horn Strobe, 2-Wire	Ceiling
SpectrAlert Advance	Indoor	PC4	Horn Strobe, 4-Wire	Ceiling
SpectrAlert Advance	Indoor	SC	Strobe	Ceiling
SpectrAlert Advance	Indoor	H	Horn	Wall/Ceiling
SpectrAlert Advance	Outdoor	P2 (K)	Horn Strobe, 2-Wire	Wall
SpectrAlert Advance	Outdoor	P4 (K)	Horn Strobe, 4-Wire	Wall
SpectrAlert Advance	Outdoor	S (K)	Strobe	Wall
SpectrAlert Advance	Outdoor	PC2 (K)	Horn Strobe, 2-Wire	Ceiling
SpectrAlert Advance	Outdoor	PC4 (K)	Horn Strobe, 4-Wire	Ceiling
SpectrAlert Advance	Outdoor	SC (K)	Strobe	Ceiling
SpectrAlert Advance	Outdoor	H (K)	Horn	Wall/Ceiling
SpectrAlert Advance	Indoor	CH	Chime	Wall/Ceiling
SpectrAlert Advance	Indoor	CHS	Chime Strobe	Wall
SpectrAlert	Indoor	CH24MC	Chime Strobe	Wall
SpectrAlert	Indoor	CH1224	Chime	Wall/Ceiling
SpectrAlert	Indoor	SP2x1224MC	Speaker Strobe	Wall
SpectrAlert	Indoor	SP3x1224MC	Speaker Strobe	Wall
SpectrAlert	Outdoor	SP2R1224MCK	Speaker Strobe	Wall
SpectrAlert		S1224MC	Strobe	Wall
SpectrAlert		P1224MC	Horn Strobe, 4-Wire	Wall
SpectrAlert		H12/24	Horn	Wall/Ceiling

Wheelock Compatible NAC Devices

The following series of Wheelock NAC devices are compatible for use on the special application outputs of NAC 1 and 2 when these outputs are configured for “Wheelock” synchronization protocol:

Model Number Series	Description
AMT-12/24	Mutilating - 3 inputs
AMT-241575, AMT-24MCW	Mutilating Strobe - 1575cd or 15,30,75,110 cd, wall
AMT-241575	Mutilating Strobe (NYC) - 1575 cd, wall
AMT-12/24 Audible Only	Mutilating Audible only
AS-121575, AS-241575	Audible Strobe - 1575 cd, wall
AS-24MCW	Audible Strobe - 15,30,75,110 cd, wall
AS-24MCC	Audible Strobe - 15,30,75,95 cd, ceiling
AS-24MCWH	Audible Strobe - 135,185 cd, wall
AS-24MCCH	Audible Strobe - 115,177 cd, ceiling
AH-12, AH-24	Audible
ASWP-2475	Audible Strobe - 180 cd, weatherproof
AHWP	Audible - outdoor
CH70, CH90	Chime
CH70-241575	Chime - 1575 cd, wall
CH70-24MCW	Chime - 15,30,75,110 cd, wall
CH90-24MCC	Chime - 15,30,75,95 cd, ceiling
CH70-MCWH	Chime - 135,185 cd, wall
CH90-MCCH	Chime - 115,177 cd, ceiling
E50-241575W	Speaker Strobe-wall
E50-MCW	Speaker Strobe - 15,30,75,110 cd, wall
E50-MCWH	Speaker Strobe - 135,185 cd, wall
E60-24MCC	Speaker Strobe 15,30,75,95 cd, ceiling
E60-MCCH	Speaker Strobe 115/177 cd, ceiling
E70A, E70B, E90A, E90B	Speaker Strobe - amber or blue lens

Model Number Series	Description
E70-241575	Speaker Strobe - 1575 cd, wall
E70-24MCW	Speaker Strobe - 15,30,75,110 cd, wall
E90-24MCC	Speaker Strobe - 15,30,75,95 cd, ceiling
E70-24MCWH	Speaker Strobe - 135,185 cd, wall
E90-24MCCH	Speaker Strobe - 115,177 cd, ceiling
ET70-241575	Speaker Strobe - 1575 cd, wall
ET70-24MCW	Speaker Strobe - 15,30,75,110 cd, wall
ET90-24MCC	Speaker Strobe - 15,30,75,95 cd, ceiling
ET70-24MCWH	Speaker Strobe - 135,185 cd, wall
ET90-24MCCH	Speaker Strobe - 115,177 cd, ceiling
ET80-24MCW	Speaker Strobe - vandal resist, 15,30,75,110 cd, wall
ET80-24MCWH	Speaker Strobe - vandal resist, 135,185 cd, wall
ET70WP-2475	Speaker Strobe - weatherproof
HS-24	Audible
HS4-241575	Audible Strobe - 1575 cd, wall
HS4-24MCW	Audible Strobe - 15,30,75,110 cd, wall
HS4-24MCWH	Audible Strobe - 135,185 cd, wall
MIZ-24S	Mini Horn - continuous, code-3, sync
MT	Multitone
MT-121575, MT-241575, MT-24MCW	Multitone Strobe - 1575 cd or 15,30,75,110 cd, wall
MTWP-2475	Multitone Strobe - weatherproof
MTWP B or A	Multitone Strobe - weatherproof-Blue or Amber lens
NH	Audible
NS-24MCC	Audible Strobe - 15,30,75,95 cd, ceiling
NS-24MCCH	Audible Strobe - 115, 177 cd, ceiling
NS-24MCW	Audible Strobe - 15,30,75,110 cd, wall
NS-121575, NS-241575	Audible Strobe - 1575 cd, wall
RSS-121575	Strobe-15,75 cd, wall

Model Number Series	Description
RSS-241575, RSSP-241575	Strobe - 15,75 cd, wall
RSS-24MCW, RSSP-24MCW	Strobe - 15,30,75,110 cd, wall
RSS-24MCC, RSS-24MCCR	Strobe - 15,30,75,95 cd, ceiling, round or square
RSS-24MCWH, RSSP-24MCWH	Strobe - 135,185 cd, wall
RSS-24MCCH, RSS-24MCCHR	Strobe - 115,177 cd, ceiling, round or square
S8, S8-24MCC, S8-24MCCH	Speaker or Speaker Strobe - 8-inch, ceiling
SA-S90-24MCC	Speaker Strobe - amplified, 15,30,75,95 cd, ceiling
SA-S70-24MCW	Speaker Strobe - amplified, 15,30,75,115 cd, wall
STH w/opt strobe	Cluster Speakers - with optional DC-MAX strobe
STH MCCH	Cluster Speakers - with 115/177 cd strobe
STH-4R24MCCH110	Cluster Speaker with three strobes
STx	Strobe - 15,15/75,30,75,95,110,135,185 cd, wall
STxC	Strobe - 15,30,60,75,95,115,150,177 cd, ceiling
HSx	Audible Strobe - 15,15/75,30,75,95,110,135,185 cd, wall
HSxC	Audible Strobe - 15,30,60,75,95,115,150,177 cd, ceiling
HNx	Audible, wall
HNxC	Audible, ceiling

VES Multiple-Listed Wheelock Models

The following VES NAC models are multiple-listed with Wheelock and are compatible for use on the special application outputs of NAC 1 and 2 when these outputs are configured for “Wheelock” synchronization protocol:

VES Models	Wheelock Models	Description
VF4103-XX	AH-24-R	Horn, Red (AH)
VF4103-XX	AH-24-W	Horn, White (AH)
VF4105-XX	AH-24WP-R	Weatherproof Horn, Red (AH)
VF4106-XX	NH-12/24-R	Horn, Red (NH)
VF4106-XX	NH-12/24-W	Horn, White (NH)
VF4108-XX	MT-12/24-R	Multi Tone Flush Red
VF4108-XX	MT-12/24-W	Multi Tone Flush White

VES Models	Wheelock Models	Description
VF4110-XX	AMT-12/24-R	Audible Multi Tone Addressable Red
VF4110-XX	AMT-12/24-W	Audible Multi Tone Addressable White
VF4202-XX	CH70-24-R	Chime Square, Red
VF4202-XX	CH70-24-W	Chime Square, White
VF4204-XX	CH90-24-W	Chime Round White
VF4327-XX	RSS-24MCW-FR	Strobe Wall Multi-Candela Red (RSS)
VF4327-XX	RSS-24MCW-FW	Strobe Wall Multi-Candela White (RSS)
VF4329-XX	RSS-241575W-FR	Strobe Wall Mount Red 15/75 cd
VF4329-XX	RSS-241575W-FW	Strobe Wall Mount White 15/75cd
VF4331-XX	RSS-24150W-FR	Strobe Wall Mount Red 150cd
VF4332-XX	RSS-24177W-FR	Strobe Wall Mount Red 177 cd
VF4333-XX	RSS-24185W-FR	Strobe Wall Mount Red 185cd
VF4334-XX	RSS-24MCC-FR	Strobe Ceiling Multi-Candela, Red (RSS)
VF4334-XX	RSS-24MCC-FW	Strobe Ceiling Multi-Candela, White (RSS)
VF4335-XX	RSS-24MCCR-FR	Strobe Ceiling Multi-Candela, Round, Red (RSS)
VF4335-XX	RSS-24MCCR-FW	Strobe Ceiling Multi-Candela, Round, White (RSS)
VF4336-XX	RSS-24MCCH-FR	Strobe Ceiling, 115/177cd, Red (RSS)
VF4336-XX	RSS-24MCCH-FW	Strobe Ceiling, 115/177cd, White (RSS)
VF4337-XX	RSS-24MCCHR-FR	Strobe Red Multi Ceiling Round 115/177 cd
VF4337-XX	RSS-24MCCHR-FW	Strobe White Multi Ceiling Round 115/177 cd
VF4338-XX	RSS-24MCWH-FR	Strobe, Wall, 135/185cd, Red (RSS)
VF4338-XX	RSS-24MCWH-FW	Strobe, Wall, 135/185cd, White (RSS)
VF4340-XX	RSS-24150C-FW	Strobe Ceiling Mount White 150cd
VF4341-XX	RSS-35288C-FW	Strobe Ceiling Mount White 177cd
VF4342-XX	RSS-2415CR-FR	Strobe Ceiling Mount Round Red 15cd
VF4342-XX	RSS-2415CR-FW	Strobe Ceiling Mount Round White 15cd
VF4344-XX	RSS-2430CR-FR	Strobe Ceiling Mount Round Red 30cd
VF4344-XX	RSS-2430CR-FW	Strobe Ceiling Mount Round White 30cd

VES Models	Wheelock Models	Description
VF4346-XX	RSS-2475CR-FR	Strobe Ceiling Mount Round Red 75cd
VF4346-XX	RSS-2475CR-FW	Strobe Ceiling Mount Round White 75cd
VF4348-XX	RSS-24100CR-FR	Strobe Ceiling Mount Round Red 100cd
VF4348-XX	RSS-24100CR-FW	Strobe Ceiling Mount Round White 100cd
VF4350-XX	RSS-24150CR-FW	Strobe Ceiling Mount Round White 150cd
VF4351-XX	RSS-24177CR-FW	Strobe Ceiling Mount Round White 177cd
VF4352-XX	RSSWP-2475W-FR	Strobe Wall Weatherproof, 75cd, Red
VF4353-XX	RSSP-24MCW-FR	Strobe Retro Multi-Candela, Red
VF4353-XX	RSSP-24MCW-FW	Strobe Retro Multi-Candela, White
VF4355-XX	RSSP-241575W-FR	Strobe Wall Mount Retrofit Plate Red 15/75cd
VF4356-XX	RSSP-24150W-FR	Strobe Wall Mount Retrofit Plate Red 150cd
VF4357-XX	RSSP-24177W-FR	Strobe Wall Mount Retrofit Plate Red 177cd
VF4358-XX	RSSP-24185W-FR	Strobe Wall Mount Retrofit Plate Red 185cd
VF4359-XX	RSSP-24MCWH-FR	Strobe Wall Mt Red Multi cd 135/185
VF4529-XX	NS-24MCW-FR	Horn/Strobe, Multi-Candela, Red (NS)
VF4529-XX	NS-24MCW-FW	Horn/Strobe, Multi-Candela, White (NS)
VF4531-XX	NS-241575W-FR	Horn/Strobe Wall Mount Flush Red 15/75cd
VF4531-XX	NS-241575W-FW	Horn/Strobe Wall Mount Flush White 15/75cd
VF4532-XX	HS4-24MCW-FR	Horn/Strobe 4-Wire, Multi-Candela, Red (NS)
VF4532-XX	HS4-24MCW-FW	Horn/Strobe 4-Wire, Multi-Candela, White (NS)
VF4533-XX	HS4-24MCWH-FR	Horn/Strobe Wall 4 Wire Red 135/185 cd
VF4533-XX	HS4-24MCWH-FW	Horn/Strobe Wall 4 Wire White 135/185 cd
VF4536-XX	NS-24MCCH-FR	Horn/Strobe, Ceiling, Round, 115/177cd, Red
VF4600-XX	AS-24MCW-FR	Horn/Strobe, Wall, Multi-Candela, Red (AS)
VF4600-XX	AS-24MCW-FW	Horn/Strobe, Wall, Multi-Candela, White (AS)
VF4602-XX	AS-241575W-FR	Audible Strobe Wall Mounted Red 15/75cd
VF4602-XX	AS-241575W-FW	Audible/Strobe Wall Mounted White 15/75cd
VF4603-XX	AS-241575W-FW	Audible Strobe Wall Mounted White 15/75cd

VES Models	Wheelock Models	Description
VF4604-XX	ASWP-2475W-FR	Weatherproof Horn/Strobe, Red (AS)
VF4605-XX	MT-241575W-FR	Audible Multi Tone Strobe Flush Red 15/75cd
VF4606-XX	MT-2475W-FR	Audible Multi Tone Strobe Flush Red 75cd
VF4607-XX	MTWP-2475W-FR	Audible Multi Tone Strobe Weatherproof Red 75cd
VF4608-XX	AMT-241575W-FR	Audible Multi Tone/Strobe Red 15/75cd
VF4609-XX	AMT-2475W-FR	Audible Multi Tone/Strobe Red 75cd
VF4610-XX	AS-24MCC-FR	Horn/Strobe, Ceiling, Multi-Candela, Red (AS)
VF4610-XX	AS-24MCC-FW	Horn/Strobe, Ceiling, Multi-Candela, White (AS)
VF4611-XX	AS-24MCCH-FR	Horn/Strobe, Ceiling, 115/177, Red (AS)
VF4611-XX	AS-24MCCH-FW	Horn/Strobe, Ceiling, 115/177, Red (AS)
VF4612-XX	AS-24MCWH-FR	Horn/Strobe, Wall, 135/185, Red (AS)
VF4612-XX	AS-24MCWH-FW	Horn/Strobe, Wall, 135/185, White (AS)
VF4670-XX	HSR	Exceder Multi-Candela Horn / Strobe Red Wall Mount
VF4670-XX	HSW	Exceder Multi-Candela Horn / Strobe White Wall Mount
VF4671-XX	HSRC	Exceder Multi Candela Horn / Strobe Ceiling Mount Red
VF4671-XX	HSWC	Exceder Multi Candela Horn / Strobe Ceiling Mount White
VF4672-XX	STR	Exceder Multi Candela Strobe Wall Mount Red
VF4672-XX	STW	Exceder Multi Candela Strobe Wall Mount White
VF4673-XX	STRC	Exceder Multi Candela Strobe Ceiling Mount Red
VF4673-XX	STWC	Exceder Multi Candela Strobe Ceiling Mount White
VF4674-XX	HNR	Exceder Horn - Red / Wall Mount
VF4674-XX	HNW	Exceder Horn - White / Wall Mount
VF4675-XX	HNRC	Exceder Horn - Red / Ceiling Mount
VF4675-XX	HNWC	Exceder Horn - White / Ceiling Mount
VF4708-XX	CH70-24MCW-FR	Chime/Strobe, Wall, Multi-Candela, Red (CH)
VF4708-XX	CJ70-24MCW-FW	Chime/Strobe, Wall, Multi-Candela, White (CH)
VF4709-XX	CH70-24MCWH-FR	Chime/Strobe Red Wall 135/185 cd
VF4709-XX	CH70-24MCWH-FW	Chime/Strobe White Wall 135/185 cd

VES Models	Wheelock Models	Description
VF4712-XX	CH70-241575-FR	Chime/Strobe Square Red 15/75cd
VF4712-XX	CH70-241575W-FW	Chime/Strobe Square White 15/75cd
VF4713-XX	CH90-24MCC-FR	Chime/Strobe, Ceiling, Multi-Candela, Red (CH)
VF4713-XX	CH90-24MCC-FW	Chime/Strobe, Ceiling, Multi-Candela, White (CH)
VF4714-XX	CH90-2475C-FW	Chime/Strobe Round White 75cd
VF4715-XX	CH90-24100C-FW	Chime/Strobe Round White 100cd
VF4716-XX	CH90-24MCCH-FW	Chime/Strobe White Round 15/30/75/95 cd
VF4817-XX	E70-24MCW-FR	Speaker/Strobe, Wall, Multi-Candela, Red (E Series)
VF4817-XX	E70-24MCW-FW	Speaker/Strobe, Wall, Multi-Candela, White (E Series)
VF4818-XX	E70-24MCWH-FR	Speaker/Strobe, Wall, 135/185, Red (E Series)
VF4818-XX	E70-24MCWH-FW	Speaker/Strobe, Wall, 135/185, White (E Series)
VF4819-XX	E70-241575W-FR	Speaker/Strobe Square 2 watt Red 15/75cd
VF4819-XX	E70-241575W-FW	Speaker/Strobe Square 2 watt White 15/75cd
VF4820-XX	E50-24MCW-FR	Speaker/Strobe Wall Mount 2 Watt Multi Candela Red
VF4820-XX	E50-24MCW-FW	Speaker/Strobe Wall Mount 2 Watt Multi Candela White
VF4821-XX	E90-24MCC-FR	Speaker/Strobe Round 2 watt Multi-Candela 15/30/75/110 Red
VF4821-XX	E90-254MCC-FW	Speaker/Strobe Round 2 watt Multi-Candela 15/30/75/110
VF4822-XX	E90-24MCCh-FW	Speaker/Strobe Ceiling White 115/177 cd
VF4823-XX	E50-241575W-FR	Speaker/Strobe Square 2 Watt Red 15/75cd
VF4823-XX	E50-241575W-FW	Speaker/Strobe Square 2 Watt White 15/75cd
VF4824-XX	E50-24MCWH-FR	Speaker/Strobe Wall Mount 2 Watt High Multi Candela Red
VF4824-XX	E50-24MCWH-FW	Speaker/Strobe Sq. 2 Watt Multi Candela White 135/185
VF4826-XX	ET70-24MCW-FR	Speaker/Strobe, Wall, Multi-Candela, Red (ET Series)
VF4826-XX	ET70-24MCW-FW	Speaker/Strobe, Wall, Multi-Candela, White (ET Series)
VF4827-XX	ET70-24MCWH-FR	Speaker/Strobe Wall Red 135/185 cd
VF4827-XX	ET70-24MCWH-FW	Speaker/Strobe Wall White 135/185 cd
VF4828-XX	ET7-241575W-FR	Speaker/Strobe Square 8 watt Red 15/75cd
VF4828-XX	ET70-241575W-FW	Speaker/Strobe Square 8 watt White 15/75cd

VES Models	Wheelock Models	Description
VF4829-XX	E60-MCC-FR	Speaker/Strobe Ceiling Mount 2 Watt Multi Candela Red
VF4829-XX	E60-24MCC-FW	Speaker/Strobe Ceiling Mount 2 Watt Multi Candela White
VF4830-XX	E60-24MCCH-FR	Speaker/Strobe Ceiling Mount 2 Watt High Multi Candela Red
VF4830-XX	E60-24MCCH-FW	Speaker/Strobe Ceiling Mount 2 Watt High Multi Candela White
VF4832-XX	ET70WP-2475W-FR	Weatherproof Speaker Strobe, Wall
VF4833-XX	ET90-24MCC-FW	Speaker/Strobe, Ceiling, Multi-Candela, Red (ET Series)
VF4834-XX	ET90-24MCCH-FW	Speaker/Strobe White Ceiling 8 Watt 115/177 cd
VF4838-XX	ET90-24150C-FW	Speaker/STrobe Round 8watt White 150cd
VF4839-XX	ET90-24177C-FW	Speaker/Strobe Round 8 watt White 177cd
VF4840-XX	ET-1080-LS-24-V	Speaker/Strobe Vandal-Proof 8watt Flush Red 15cd
VF4840-XX	ET-1080-LS-24-V	Speaker/Strobe Vandal-Proof 8 Watt Flush White 15cd
VF4842-XX	ET-1080-LSM-24-	Speaker/Strobe Vandal-Proof 8watt Flush Red 15/75cd
VF4842-XX	ET-1080-LSM-24-	Speaker/Strobe Vandal Proof 8 Watt Flush White 15/75cd
VF4844-XX	ET-1080-MS-24-V	Speaker/Strobe Vandal Proof 8watt Flush Red 30cd
VF4844-XX	ET-1080-MS-24-V	Speaker/Strobe Vandal Proof 8watt Flush White 30cd
VF4846-XX	ET-108-IS-24-VF	Speaker/Strobe Vandal Proof 8 watt Flush Red 75cd
VF4846-XX	ET-1080-IS-24-V	Speaker/Strobe Vandal Proof 8 watt Flush White 75cd
VF4848-XX	ET-1080-SLM-24-	Speaker/Strobe Vandal Proof 8watt Flush Red 15/75cd
VF4848-XX	ET-1080-SLM-24-	Speaker/Strobe Vandal Proof 8 watt Flush White 15/75cd
VF4906-XX	MIZ-24S-R	Mini Horn, Red
VF4906-XX	MIZ-24S-W	Mini Horn, White
VF8004-XX	PS-24-8MC	NAC Extender, 8 Amp, 4 Output, Red

Riser conductors shall be installed in accordance with the survivability from attack by fire requirements in National Fire Alarm Code, NFPA 72, Sections 6.8.6.3, and 6.9.4. Riser conductors shall employ either a 2 hour rated cable system, or meet requirements approved by the AHJ, or installation of the Supervised Output Module using NFPA Style 7 configuration.”

Maximum Line Impedance

VES, LLC
Elite-RS Panel Installation Manual
A-Series

VF3532-00, Revision E01.06

Reference Section 1-D, Notification Appliance Circuit (NAC) for calculations of maximum line impedance.

Compatible Devices for Auxiliary 24V

VES DEVICE	MODEL	DESCRIPTION
Remote display and annunciator	VF1172	eView
Graphic Annunciator	VF13XX-YYY	eMatrix
Multichannel Input/ Output Card	VF1171	16 Channel I/O Interface

Power connections of the remote display and annunciators must be terminated at the 24 volt terminals of the 24V OUT or AUX 24V on the Elite-RS Panel.

This page intentionally left blank.

Appendix C Calculations

This section describes current-loading, the standby-battery rating and the NAC wiring length.

Current-Loading

Current-loading of the Elite-RS Panel is limited to the capacity of the 5.25 Amp power supply. FACP installers must determine the loading placed on the power supply by adding the sum of device-loads to the no-load-alarm current of the Elite-RS Panel. The result obtained from this calculation must be below 4 Amps of the 5.25 Amp power supply so that the Elite-RS Panel can operate.

The power supply of the Elite-RS is rated at 5.25 Amps where 1.25 Amps is reserved for charging the standby-batteries and 4 Amps is reserved for operating the control panel and external loads. The 4 Amp reserve of the 5.25 Amp power supply is the maximum current capacity of the Elite-RS Panel. The control panel will not function properly if the operating constant of 4 Amps is exceeded.

Current limits are provided in *Appendix A, "Specifications"* for each of the circuit-connections on the Elite-RS Panel. Installers must identify the current-draw of each device on the circuit-connection and then compare the sum of these device-currents with the current limit provided for each of the circuit-connections. The total of device-currents must be below the limits provided in *Appendix A, "Specifications"* for each circuit-connection.

The calculation of total-current-loading must include the sum of device-loads on each of the Elite-RS circuits. Circuits to be included in this calculation for total-current-loading are:

- Panel standby and alarm currents
- SLC Loops
- NAC Outputs
- 24V OUT
- AUX 24V

The current limits provided in Appendix A, "Specifications" are maximums for each of the circuit-connections on the Elite-RS Panel. These levels are not intended to be summed together to determine the total-current available from the Elite-RS Panel. Refer to these levels only when determining the limit of device-loading on each circuit.

Example of Total Load Current

The following example demonstrates the process for determining the total load-current of the Elite-RS Panel:

- 1 Identify the current-draw of each device on the circuit-connection.
- 2 Add the device-currents together in each circuit-connection.
- 3 Compare the sum of the device-currents with the current-limit of each circuit-connection to verify that the summed level is below the current-limit value.
- 4 Add the device-load-currents together that were obtained for each of the circuit-connections:

Circuit-Connection	Current Limit	Device Load Current
SLC Loop 1	250 mA	150 mA
SLC Loop 2	250 mA	50 mA
24V OUT	360 mA	0
AUX 24V	360 mA	0
NAC Channel 1 Regulated Output	1.6 A continuous DC or 900 mA pulse DC	750 mA continuous DC
NAC Channel 2 Special Application Output	Single NAC output 2.3 A continuous with combined NAC outputs not to exceed 3.1 A continuous	925 mA continuous DC
Total Device Load		1.875 A

- 5 Add the Total Device Load to the no-load-alarm current of the Elite-RS to obtain the Total-Load-Current.

Total Device Load + Elite-RS No-Load = Total-Load-Current

$$1.875 \quad + \quad 200 \text{ mA} \quad = \quad 2.075 \text{ A}$$

Total Load Current: **2.075 A**

- 6 Verify that the current level is below 4 Amps:

2.075 A < 4 A This example demonstrates that device-loading *does not exceed* the 4 Amp capacity of the Elite-RS power supply.

Determining the Standby-Battery Rating

This section provides guidelines for determining the standby-battery rating of the Elite-RS Panel.

Battery Rating Equation

The equation below describes the process for determining the Amp-Hour Rating of the standby-batteries:

$$\text{Battery Rating} = (\text{Battery Derating Factor}) \times [(\text{Standby Amp Hours}) + (\text{Alarm Amp Hours})]$$

Or

$$\text{Battery Rating} = (\text{Battery Derating Factor}) \times [(24 \text{ Hours} \times \text{Standby-Current}) + (5 \text{ Minutes} \times \text{alarm current})]$$

Where the Battery Derating Factor = 1.2 and 5 minutes = 5 / 60 minutes = 1/12 = .0833 hours.

To determine the battery Amp-Hour-Rating:

- 1 Record the standby and alarm currents of VES Devices.
- 2 Record the standby and alarm currents of NAC Devices.
- 3 Record the standby and alarm currents of Auxiliary Devices.
- 4 Total the standby and alarm currents of SLC 1, SLC 2, NAC 1, NAC 2, AUX 24V and 24V OUT.
- 5 Calculate the Total Standby Amp Hours.
- 6 Calculate the Total Alarm Amp Hours.
- 7 Determine Total Amp-Hours by adding the Total Standby Amp Hours with the Total Alarm Amp Hours.
- 8 Determine the minimum Amp-Hour-Rating for the battery by multiplying the Total Amp-Hours with the Derating Factor (1.20).
- 9 Select a battery with a rating equal to or greater than the minimum Amp-Hour-Rating determined in step 8.

Complete the worksheets on the following pages to tabulate the total-current-load of the FACP system and to determine the minimum Amp-Hour-Rating for the standby-batteries.

Compare the sum of currents drawn by devices of the system and compare these to the values listed in the table of Appendix C. Select a corresponding standby-battery based on this comparison.

Tabulating Data

	Category	Instruction	Standby-Current	Alarm-Current
1	VES Devices	Enter the total standby and alarm current for VES Devices.	Amps	Amps
2	NAC Devices	Enter the total standby and alarm current for NAC Devices.	Amps	Amps
3	Auxiliary Devices	Enter the total standby and alarm current for Auxiliary Devices.	Amps	Amps
4	Total Standby and Alarm Current	Total the Standby Current of steps 1, 2 and 3. Total the Alarm Current of steps 1, 2 and 3.	Amps	Amps
5	Total Standby Time	Enter a Total Standby Time of 24 or 60 hours.	Hours	
6	Total Standby Amp-Hours	Multiply the Total Standby Time of step 5 by the Total Standby Current of step 4.	AH	
7	Total Alarm Time	Enter a Total Alarm Time in hours, where 5 minutes = .083 hours and 15 minutes = .25 hours.		Hours
8	Total Alarm Amp Hours	Multiply the Total Alarm Time in step 7 with the Total Alarm Current of step 4.		AH
9	Total Amp-Hours	Add the Total Alarm Amp Hours of step 8 with the Total Standby Amp Hours of step 6.		AH
10	Derating factor	The Derating Factor is 1.20.		1.20
11	Minimum Battery Amp-Hour Rating	Multiply the Derating Factor of step 10 (1.20) by the Total Amp-Hours of step 9. The Amp-Hour-Rating of the battery selected must be equal to or greater than the minimum Amp-Hour-Rating obtained in this step. Note: The Maximum battery size is 50 AH.		AH

NAC Wiring Length

Determine the maximum wire length that can safely operate Notification Appliances under worst case conditions. To determine the maximum wire length under worst case conditions:

- 1 Identify the minimum operating-voltage ($V_{op_{min}}$) of Notification Appliances on the NAC channel.
- 2 Calculate the maximum current of the circuit (I_{max}).
- 3 Identify the wire-resistance-per-foot of the circuit (R_{wire}).
- 4 Calculate the maximum wire length (L_{max}) of the circuit.

Sample L_{max} Calculation

Determine the maximum wire length (L_{max}) for three Notification Appliances on NAC channel 1 where,

- The manufacturer data sheet for the strobe indicates that the minimum operating-voltage ($V_{op_{min}}$) is 16 VDC.
- The manufacturer data sheet for the strobe indicates that the maximum current-draw (I_{strobe}) is 209mA DC.
- The circuit connection is provided with 18 AWG solid-copper-wire.
- The EOLD in the circuit is 10K Ohms.

To determine the maximum wire length (L_{max}) of this circuit:

- 1 Identify the minimum operating-voltage ($V_{op_{min}}$) of the strobe from the manufacturer data sheet.
From the manufacturer data sheet:

$$V_{op_{min}} = 16 \text{ VDC}$$

- 2 Calculate the total current of the parallel devices in the circuit (I_{total}) where,

$$\begin{aligned} [I_{total} &= I_{strobe_1} + I_{strobe_2} + I_{strobe_3} + (V_{op_{min}} / EOLD)] \\ &= [(.209 + .209 + .209 + 16 / 10K)] \text{ A} \\ &= (.627 + .0016) \text{ A} \end{aligned}$$

$$I_{total} = .6286 \text{ A}$$

- 3 Identify the maximum resistance of the wire gage used in the circuit (R_{wiremax}) when using 18 AWG copper. An 18 AWG solid copper wire is 6.385 Ohms at 1000FT using the Resistance Table below:

Gage	Resistance / 1000Ft @ 68F	R_{wire}
18 AWG	6.385 Ohms	0.006385 Ohms / FT
16 AWG	4.016 Ohms	0.004016 Ohms / FT
14 AWG	2.525 Ohms	0.002525 Ohms / FT

- 4 The calculation for the minimum output voltage of the NAC is:

$$\begin{aligned} V_{\text{outmin}} &= V_{\text{panel}} \times 85\% \\ &= 24 \text{ VDC} \times 85\% \end{aligned}$$

$$V_{\text{outmin}} = 20.4 \text{ VDC}$$

- 5 The calculation for voltage-drop across the length of the wire is:

$$\begin{aligned} V_{\text{drop}} &= V_{\text{outmin}} - V_{\text{opmin}} \\ &= 20.4 \text{ VDC} - 16 \text{ VDC} \end{aligned}$$

$$V_{\text{drop}} = 4.4 \text{ VDC}$$

- 6 The calculation for maximum wire length of this circuit is:

$$L_{\text{max}} = 1/2 (V_{\text{drop}} / I_{\text{max}}) / R_{\text{wire}}$$

where,

$$= 1/2 [(4.4 / .6286) / (.006385 \text{ Ohms / FT })]$$

$$L_{\text{max}} = 548 \text{ FT}$$

The figure below illustrates an example circuit for determining maximum wire length where values are provided for minimum operating-voltage of the NAC channel output (V_{opmin}), maximum current of the circuit (I_{max}), wire-resistance-per-foot of the circuit (R_{wire}) and maximum current-draw of the strobe (I_{strobe}):

Figure C-1
Example Circuit For Determining Maximum Wire Length

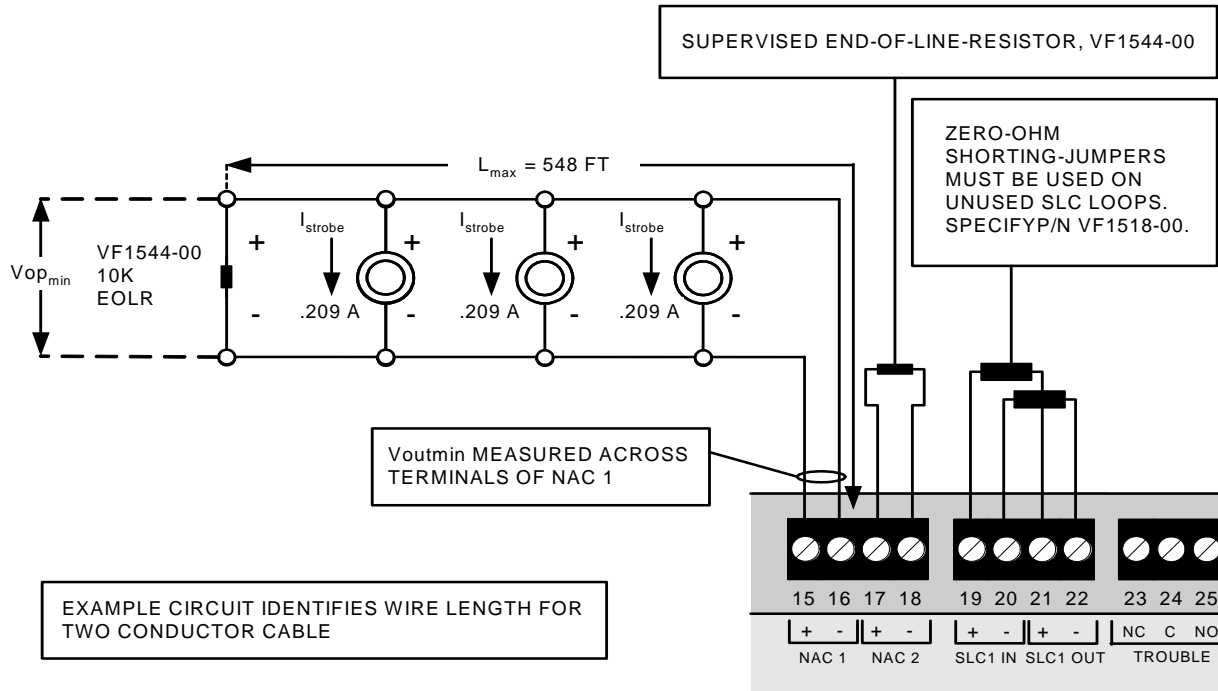

This page intentionally left blank.

WIRING DIAGRAM FOR THE A AND H SERIES GLAN-RS AND ELT-RS CONTROL PANEL

FOR INDOOR DRY USE ONLY

Table with 2 columns: Terminal, Connection, Rating, Description. Rows include 11-14, 15-18, 19-22, 23-26.

Table with 2 columns: Terminal, Rating, Description. Rows include 1-4, 5-8, 9-12, 13-16.

Table with 2 columns: Terminal, Rating, Description. Rows include 17-20, 21-24, 25-28, 29-32.

Table with 2 columns: Terminal, Rating, Description. Rows include 33-36, 37-40, 41-44, 45-48.

Table with 2 columns: Terminal, Rating, Description. Rows include 49-52, 53-56, 57-60, 61-64.

WARNING: THE UNIT INCLUDES AN OPTIONAL... APPROVED BY THE LOCAL AUTHORITY...

Table with 2 columns: Terminal, Rating, Description. Rows include 1-4, 5-8, 9-12, 13-16.

Table with 2 columns: Terminal, Rating, Description. Rows include 17-20, 21-24, 25-28, 29-32.

Table with 2 columns: Terminal, Rating, Description. Rows include 33-36, 37-40, 41-44, 45-48.

Table with 2 columns: Terminal, Rating, Description. Rows include 49-52, 53-56, 57-60, 61-64.

Table with 2 columns: Terminal, Rating, Description. Rows include 65-68, 69-72, 73-76, 77-80.

Table with 2 columns: Terminal, Rating, Description. Rows include 81-84, 85-88, 89-92, 93-96.

Table with 2 columns: Terminal, Rating, Description. Rows include 97-100, 101-104, 105-108, 109-112.

Table with 2 columns: Terminal, Rating, Description. Rows include 113-116, 117-120, 121-124, 125-128.

Table with 2 columns: Terminal, Rating, Description. Rows include 129-132, 133-136, 137-140, 141-144.

Table with 2 columns: Terminal, Rating, Description. Rows include 145-148, 149-152, 153-156, 157-160.

Table with 2 columns: Terminal, Rating, Description. Rows include 161-164, 165-168, 169-172, 173-176.

INSTALL MODELS OF THE ELT-RS PANELS OPERATING ON 24VDC... 24VDC @ 300 mA...

Table with 2 columns: Terminal, Rating, Description. Rows include 177-180, 181-184, 185-188, 189-192.

Table with 2 columns: Terminal, Rating, Description. Rows include 193-196, 197-200, 201-204, 205-208.

Table with 2 columns: Terminal, Rating, Description. Rows include 209-212, 213-216, 217-220, 221-224.

Table with 2 columns: Terminal, Rating, Description. Rows include 225-228, 229-232, 233-236, 237-240.

Table with 2 columns: Terminal, Rating, Description. Rows include 241-244, 245-248, 249-252, 253-256.

Table with 2 columns: Terminal, Rating, Description. Rows include 257-260, 261-264, 265-268, 269-272.

Table with 2 columns: Terminal, Rating, Description. Rows include 273-276, 277-280, 281-284, 285-288.

Table with 2 columns: Terminal, Rating, Description. Rows include 289-292, 293-296, 297-300, 301-304.

Table with 2 columns: Terminal, Rating, Description. Rows include 305-308, 309-312, 313-316, 317-320.

AG LINE CONNECTION: INPUT SUPPLY, OUTPUT VOLTAGE, OUTPUT CURRENT, CHARGE CURRENT, BATTERY TYPE, TRANSFER VOLTAGE.

AC LINE CONNECTION: TERMINAL, DESCRIPTION, VOLTAGE, CURRENT. Includes notes on input and output ratings.

AG LINE CONNECTION: TERMINAL, DESCRIPTION, RATING. Includes notes on specific terminal requirements.

Table with 2 columns: Terminal, Rating, Description. Rows include 321-324, 325-328, 329-332, 333-336.

Table with 2 columns: Terminal, Rating, Description. Rows include 337-340, 341-344, 345-348, 349-352.

Table with 2 columns: Terminal, Rating, Description. Rows include 353-356, 357-360, 361-364, 365-368.

Table with 2 columns: Terminal, Rating, Description. Rows include 369-372, 373-376, 377-380, 381-384.

Table with 2 columns: Terminal, Rating, Description. Rows include 385-388, 389-392, 393-396, 397-400.

Table with 2 columns: Terminal, Rating, Description. Rows include 401-404, 405-408, 409-412, 413-416.

AG LINE CONNECTION: TERMINAL, DESCRIPTION, RATING. Includes notes on terminal connections.

AG LINE CONNECTION: TERMINAL, DESCRIPTION, RATING. Includes notes on terminal connections.

AG LINE CONNECTION: TERMINAL, DESCRIPTION, RATING. Includes notes on terminal connections.

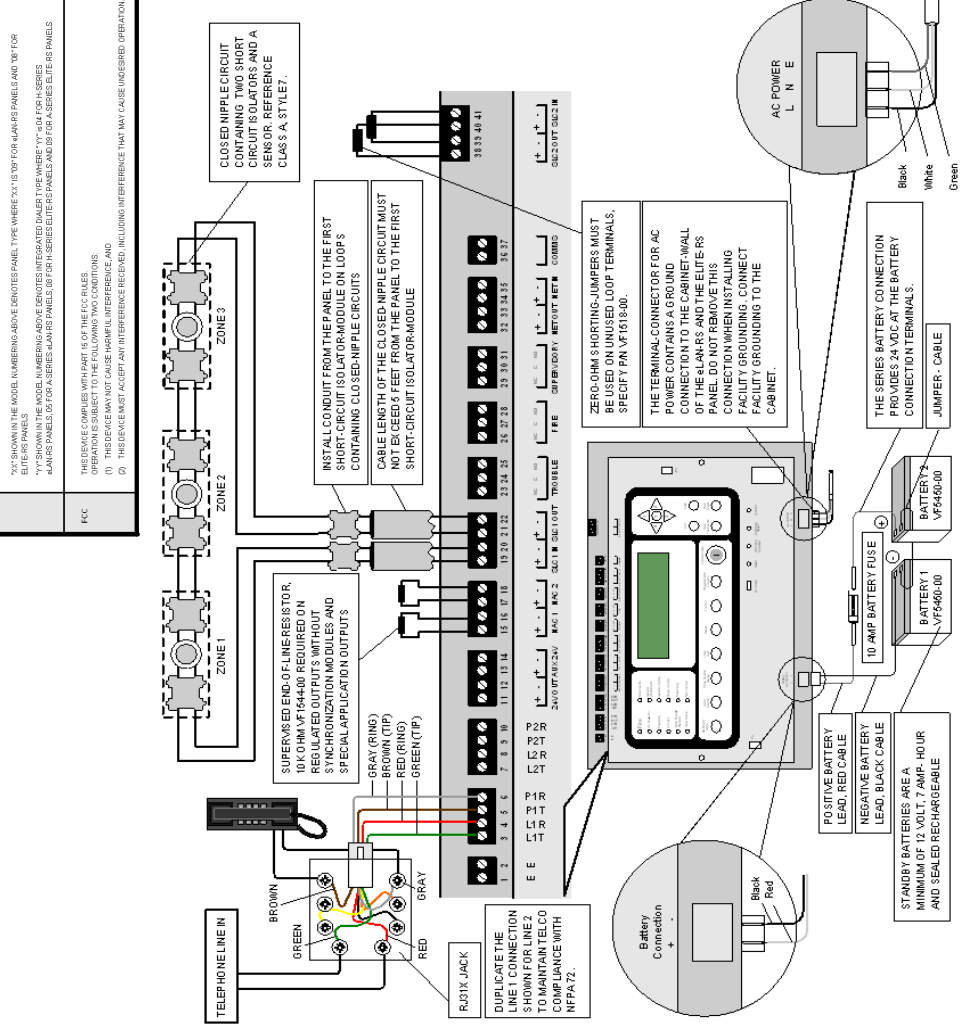

Table with 2 columns: Terminal, Rating, Description. Rows include 1-4, 5-8, 9-12, 13-16.

GROUND FAULT INDICATION: A GROUND FAULT INDICATION OCCURS ON MODELS OF THE GLAN-RS ELT-RS PANEL WHEN A SHORT CIRCUIT OCCURS BETWEEN THE BATTERY AND EITHER THE EARTH-GROUND AND/OR POWER SUPPLY.



This page intentionally left blank.

OPERATING INSTRUCTIONS

OPERATING INSTRUCTIONS FOR ALL MODELS OF THE eLAN-RS, AND ELITER-S PANEL

PATENT PENDING

LED INDICATORS



Key	LED	Color	LED Lit
A	Fire	Red	An alarm or fire drill condition exists. The status panel buzzer sounds intermittently. The control panel buzzer sounds continuously. Output relays are activated. <ul style="list-style-type: none"> Flicking = MACs activated On Continuous = MACs silenced OFF = Panel and MACs reset
B	AC Power On	Green	AC power is on.
C	Pre-Alarm	Yellow	A pre-alarm condition exists. Pre-alarm status is provided on the LCD display. The buzzer on the control panel sounds continuously.
D	On Test	Yellow	A test is in progress.
E	Panel Sounder Silenced	Yellow	The Panel Sounder Silence button was depressed. NAC outputs are not affected.
F	Delay Active	Yellow	Warning sounders have been delayed during a fire condition. Press the Alarm Silence button to mute or extend the delay to a second stage delay.
G	More Events	Yellow	A non-fire alarm event exists. The e-LAN buzzer sounds continuously.
H	Point Bypassed	Yellow	LCD menu options have been used to disable devices.
I	General Trouble	Yellow	A General Trouble condition exists when flashing. The buzzer on the control panel sounds in three LEDs. Status is provided on the LCD display. The buzzer on the control panel sounds continuously.
J	Power Trouble	Yellow	A Power Trouble exists. Status is provided on the LCD display. The buzzer on the control panel sounds continuously.
K	Supervisory Alarm	Yellow	Status is provided on the LCD display. The buzzer on the control panel sounds continuously.
L	NAC Trouble	Yellow	A NAC Trouble exists on one or both of the MAC connections at this location or faulty or disabled.

CONTROLS

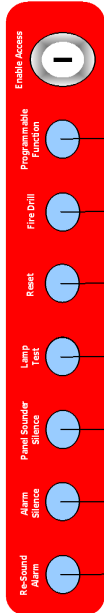

Key	Name	Description	Operation
A	Re-Sound Alarm	Re-sounds alarm of control panel after the condition is silenced. Press the Alarm Silence button. Re-sounds NAC alarms silenced by the Alarm Silence button.	1 Press 3 to display "SET ACCESS LEVEL 2 MENU" authorization. 2 Provide Access Level 2 authorization. 3 Press Enter 4 Press the Re-Sound Alarm button.
B	Alarm Silence	Silences MACs. Also silences the buzzer of the control panel and the internal trouble and alarms.	1 Press 3 to display "SET ACCESS LEVEL 2 MENU" authorization. 2 Provide Access Level 2 authorization. 3 Press Enter 4 Press the Alarm Silence button.
C	Panel Sounder Silence	Mutes the buzzer of the control panel only.	Press the Panel Sounder Silence button.
D	Lamp Test	Tests LEDs of the control panel. Also tests the LCD display and the internal buzzer.	Press the Lamp Test button to illuminate all LEDs, and on the front panel display and sound the buzzer of the control panel.
E	Reset	Resets latching inputs such as fire and pre-alarm events.	1 Press 3 to display "SET ACCESS LEVEL 2 MENU" authorization. 2 Provide Access Level 2 authorization. 3 Press Enter 4 Press the Reset button.
F	Fire Drill	Provides a panel Fire Drill. The Fire Drill button can also be configured to perform other functions.	1 Press 3 to display "SET ACCESS LEVEL 2 MENU" authorization. 2 Provide Access Level 2 authorization. 3 Press Enter. 4 Press the Fire Drill button. To stop the fire drill: 1 Press 4 to display the "SET ACCESS LEVEL 2 MENU". 2 Provide Access Level 2 authorization. 3 Press Reset or Fire Drill.
G	Programmable Function	The Programmable Function button can be configured to perform other functions.	Requires ACCESS LEVEL 3 to configure the button.

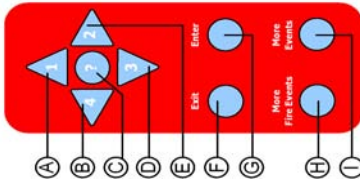

Key	Name	Description	Operation
A	Up	Navigates menu selections up.	Press 1 to navigate menu selections up.
B	Down	Navigates menu selections down.	Press 4 to navigate menu selections down.
C	Left	Provides a "help screen" for the current menu display and also displays status.	Press 7 to provide status of the control panel on the LCD display.
D	Right	Navigates menu selections right.	Press 3 to navigate menu selections right.
E	Enter	Executes the current menu selection and returns to the main menu.	Press 2 to navigate menu selections right. Press Exit to cancel the current menu selection and return to the main menu.
F	Exit	Enables the menu selection.	Press Enter to enable the menu selection.
G	More Fire Events	Displays the number of alarms present and overrides the display provided by menu navigation. Provides event status for fires.	1 Press the More Fire Events button. 2 Read event on LCD. 3 Press 3 to scroll through events. 4 Press 2 to display event. 5 Press 2 to scroll through events.
H	More Events	Displays the number of events and overrides menu navigation. Provides event status for non-fire alarm events.	1 Press the More Events button. 2 Read event on LCD. 3 Press 2 to scroll through events. 4 Press 2 to display event. 5 Press 2 to scroll through events.

MAINTENANCE AND REPAIR

REPLACING THE 3 AMP POWER-SUPPLY FUSE

- TO REMOVE THE FUSE:**
- TURN OFF 120 VAC POWER TO THE CONTROL PANEL.
 - LOCATE THE 3 AMP FUSE ON THE MAIN CIRCUIT BOARD OF THE CONTROL PANEL.
 - GENTLY INSERT A SMALL FLAT-BLADE SCREW DRIVER INTO THE SLOT OF THE FUSE HOUSING.
 - SLIDE THE LENGTH OF THE SCREW DRIVER INTO THE SLOT OF THE FUSE HOUSING UNTIL THE UPPER-HALF DISLODGES FROM THE LOWER-HALF OF THE HOUSING.
 - REMOVE THE FUSE FROM THE UPPER-HALF OF THE FUSE HOUSING.
- TO INSTALL THE NEW FUSE:**
- INSERT THE FUSE IN THE UPPER-HOUSING.
 - CENTER THE POSITION OF THE FUSE IN THE UPPER-HOUSING.
 - PRESS THE UPPER-HOUSING ON THE LOWER-HOUSING UNTIL THE HALVES SNAP TOGETHER.
 - RESTORE 120 VAC POWER TO THE CONTROL PANEL.
 - CHECK CONTROL PANEL OPERATION FOLLOWING THE PRECAUTIONS COMPANY THAT USE REPLACEMENT RESTORED FUNCTIONALITY.

REPLACING THE 10 AMP BATTERY FUSE

- TO REMOVE THE FUSE:**
- DISCONNECT THE JUMPER-CABLE BETWEEN BATTERY 1 AND BATTERY 2.
 - DISCONNECT THE RED-CABLE FROM THE POSITIVE TERMINAL OF BATTERY 2.
 - DISCONNECT THE BLACK-CABLE FROM THE NEGATIVE TERMINAL OF BATTERY 1.
 - DISPOSE THE CABLES DESCRIBED IN THE STEPS ABOVE.
 - REMOVE BATTERY 1 AND BATTERY 3 FROM THE BOTTOM OF THE CABINET AND RECYCLE THEM ACCORDING TO MANUFACTURER GUIDELINES.
- TO INSTALL THE NEW FUSE:**
- MOUNT THE REPLACEMENT BATTERIES IN THE BASE OF THE CONTROL PANEL CABINET.
 - CONNECT THE REPLACEMENT JUMPER-CABLE FROM THE NEGATIVE TERMINAL OF BATTERY 1 TO THE POSITIVE TERMINAL OF BATTERY 2.
 - CONNECT THE BLACK WIRE OF THE REPLACEMENT BATTERY-CABLE TO THE NEGATIVE TERMINAL OF BATTERY 2.
 - CONNECT THE RED WIRE OF THE REPLACEMENT BATTERY-CABLE TO THE POSITIVE TERMINAL OF BATTERY 1.
 - DETERMINE THAT TROUBLE CONDITIONS ARE NOT REPORTED BY THE CONTROL PANEL FOLLOWING THE FUSE REPLACEMENT.

OPERATING CHARACTERISTICS NORMAL STANDBY

THE FOLLOWING FORMAT APPEARS ON THE FRONT-PANEL DISPLAY WHEN OPERATING WITHOUT TROUBLES OR ALARMS:

TIME, DAY, DATE
 REPEAT OR USER DEFINED MESSAGE
 USE ARROW KEYS TO DISABLE PANEL.
 PRESS 7 FOR HELP

TROUBLE-SILENCE

THE FOLLOWING CONDITIONS OCCUR AFTER PRESSING THE "PANEL SOUNDER SILENCE" BUTTON TO SILENCE A TROUBLE:

- THE GENERAL TROUBLE LED FLASHES YELLOW.
- THE POWER TROUBLE LED FLASHES YELLOW.
- THE INTERNAL SOUNDER DOES NOT ANNOUNCE THE LCD DISPLAY PROVIDES A MESSAGE TO IDENTIFY THE TROUBLE CONDITION.

IN THE EVENT OF TROUBLE

INSTALL CONTROL PANEL MODELS OF THE eLAN-RS OR ELITER-S IN ACCORDANCE WITH THE FOLLOWING DOCUMENTS:

- eLAN-RS H INSTALLATION MANUAL, VF3828-00, REV. EDI.XX
- eLAN-RS A INSTALLATION MANUAL, VF3831-00, REV. EDI.XX
- ELITER-S H INSTALLATION MANUAL, VF3829-00, REV. EDI.XX
- ELITER-S A INSTALLATION MANUAL, VF3832-00, REV. EDI.XX

FRAME THESE INSTRUCTIONS AND PLACE THEM ADJACENT TO THE CONTROL UNIT FOR READY REFERENCE.

CONTACT:

NAME: _____

ADDRESS: _____

CITY: _____

STATE: _____

ZIP: _____

TELEPHONE: _____

STANDBY BATTERIES ARE SEALED-RECHARGEABLE AND PROVIDE FACP RECOVERY IN THE EVENT OF POWER FAILURE. INSPECT STANDBY BATTERIES AND CONNECTIONS ANNUALLY. REPLACE STANDBY BATTERIES EVERY 3 TO 5 YEARS. CONNECT STANDBY BATTERIES IN SERIES. DO NOT CONNECT STANDBY BATTERIES IN PARALLEL.

PART NUMBER: VF3835-00, REVISION: EDI.00
 DATE: 08/08/09

This page intentionally left blank

Appendix F

Communications Format

The Embedded Dialer of the Elite RS panel is capable of communicating signals to an Industry Standard Receiver in either SIA (level 2 or 3) or Contact ID formats. Both Formats use a predefined event library for transmission. In either of the formats the user may select whether they desire point ID reporting or Zone reporting.

In both Contact ID and SIA the library of translation codes sent to the monitoring center are fixed. There are no user methods for alteration of the translations.

Reference Appendix G, Reporting Formats for the appropriate matrix.

No matter the reporting format selection, one or two telephone lines may be used (NFPA mandates 2). The primary monitoring center may have one or two numbers in order to reach the Industry Standard Receiver. It is also permissible to have dual reporting to secondary monitoring center.

VES recommends SIA reporting in point format. This method of reporting supplies the most detailed information possible to the monitoring center. Desired functionality and capabilities of your monitoring center should dictate your dialer reporting configuration.

Contact ID

Contact ID uses a 4 digit account number and a two digit partition number for transmission of all signals. The partition number is equivalent to the node number of the panel and is not alterable by any other means.

Zone ID Reporting

The zone number of the signal (0-500) will be reported in the zone field of the transmission. The event code generated will be based upon the point which tripped within the zone, and will reference the standard contact ID library.

Reference Appendix G, Reporting Formats for translation details between the panel event and the Contact ID Library.

Point ID Reporting

The point reporting uses the zone number field in order to depict the precise point of occurrence, regardless of the zone which the point resides in. Since Contact ID only provides a three digit field there are some limitations to this functionality.

Field Lpp

The field is depicted by Lpp:

Where L = loop (0-2) [0=panel I/O]

Where pp= Decimal point value (00-99)

Point Values

Only point values less than or equal to 99 are allowed. If you utilize points in excess of 99, truncation of the point value will occur. The least significant byte would be dropped from the transmission. Confusion by the monitoring center would be assured [SIA format does not have this limitation].

Subpoint Values

Subpoint values are not able to be sent to the monitoring center. If a subpoint was to activate the proper event code and main point number would be transmitted, although you would not know the subpoint value.

SIA

SIA uses a 4 digit account number along with a modifier code packet (ri) in order to indicate the area or group. The area or group number is equivalent to the node number of the panel and is not alterable by any other means.

Zone ID Reporting

The zone number of the signal (0-500) will be reported in the zone field of the transmission. The event code generated will be based upon the point which tripped within the zone, and will reference the standard SIA Event Block Data Code definitions.

Reference Appendix G, Reporting Formats for translation details between the panel event and the Block Data Code Definition.

Point ID Reporting

Point reporting uses the zone number field to depict the precise point of occurrence, regardless of the zone which the point resides in. Some interpretation is required to map the point number to what is sent to the monitoring center.

Reference the matrix to see precise representation of the calculations.

Field Lpp

The field is depicted by Lpps:

Where L = loop (0-2) [0=panel I/O]

Where pp= hexadecimal point value (00-FF)

Where s = subpoint value (0-3)

Point Value

As a result of the point number being represented in hexadecimal points from 00 – 255 can be annunciated.

Subpoint values are sent to the monitoring center with full subpoint reporting.

Point ID Reporting Format

Point ID reporting format provides the highest degree of information to the monitoring center.

Dialing Methodology

The embedded dialer uses an algorithm in order to attempt transmission to the monitoring center. This algorithm is affected by the number of lines in use.

Dialing Facilities

If the user selects both line 1 and line 2, not only will both lines be used to try and dial the monitoring center, both lines will be periodically checked to see voltage is present (this is not an assurance that the line is viable, although a standard test).

If 1 line is checked the transmission and voltage checking will occur on only that line.

If neither line is checked the dialer will never attempt to send a message.

Dialing Sequence

Two Phone Lines In Use

Single Monitoring Center telephone Number (Only Account 1 Tab filled in)

Try Line	1	2	3	4	5	6	7	8	9	10
1	X	X	X			X	X	X		
2				X	X				X	X

After try 5, a communications failure is declared. This failure will restore once a transmission is successful. The user will note that another ten tries will occur after this sequence. These additional tries would be indicative of attempts to send the comm. failure event.

Answering Methodology

The embedded dialer allows incoming calls to line #1 only. The Incoming methodology allows users to remotely program through Loop Explorer configuration software. Additionally VES technical support can use this facility to assist with diagnostics of the system.

24 Hour Test Report

The embedded dialer will send a 24 hour test report signal based upon the test code time filled in within the Accounts tab of the configure dialer settings dialog. If the 4th reporting criteria (Report Service/Test) box is not enabled, no test signal will be generated.

Configure Dialer Settings

Loop Explorer [VES PC Panel programming Software] allows the user to configure the embedded dialer based upon the elements of a particular installation and the monitoring center being used. Although the dialer may be configured through level 3 setting at the front of the panel, not all options are panel programmable, and ease of operation is much more favorable with Loop Explorer.

After an auto-learn, a RS panel even though equipped with a dialer, will not provide any dialer functionality without user programming. Once an auto-learn has been accomplished, connect a programming cable to your laptop and the computer port of the control panel. Make certain the slide switch on the control panel is set to PC and not dialer. Perform synchronization from the panel to your computer.

Once complete a screen similar to Figure F-1 will be present:

Figure F-1
Completed Screen

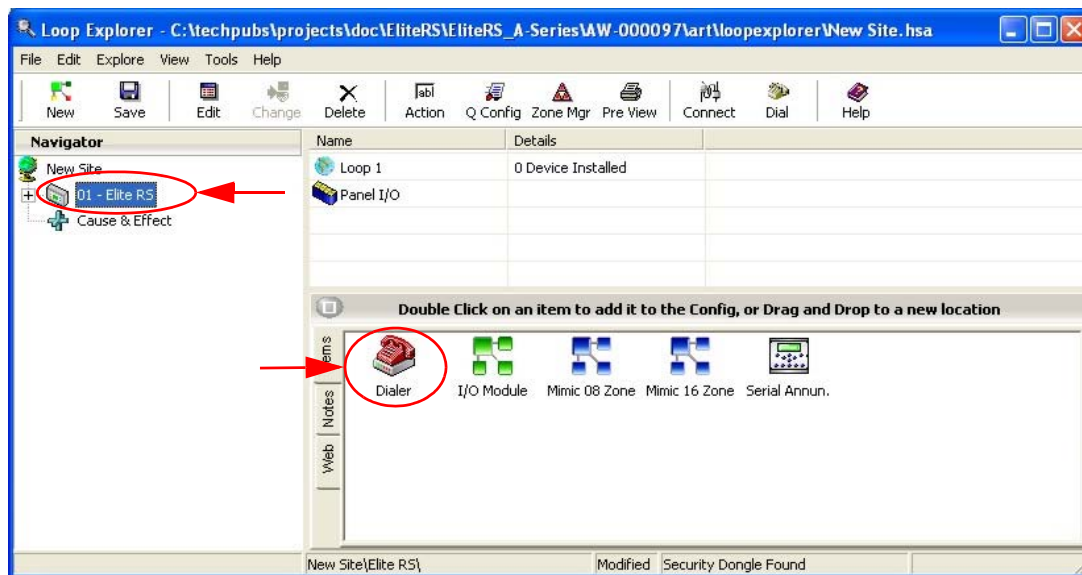

After all of your loop explorer programming is complete; make certain the slide switch is returned to the Dialer position. Failure to return this switch to the dialer position will disable dialer communications.

In the navigator (right pane) make certain the control panel is highlighted. Now Double click on the dialer icon located in the bottom pane.

This action will populate a dialer as illustrated in Figure F-2:

**Figure F-2
Populated Dialer**

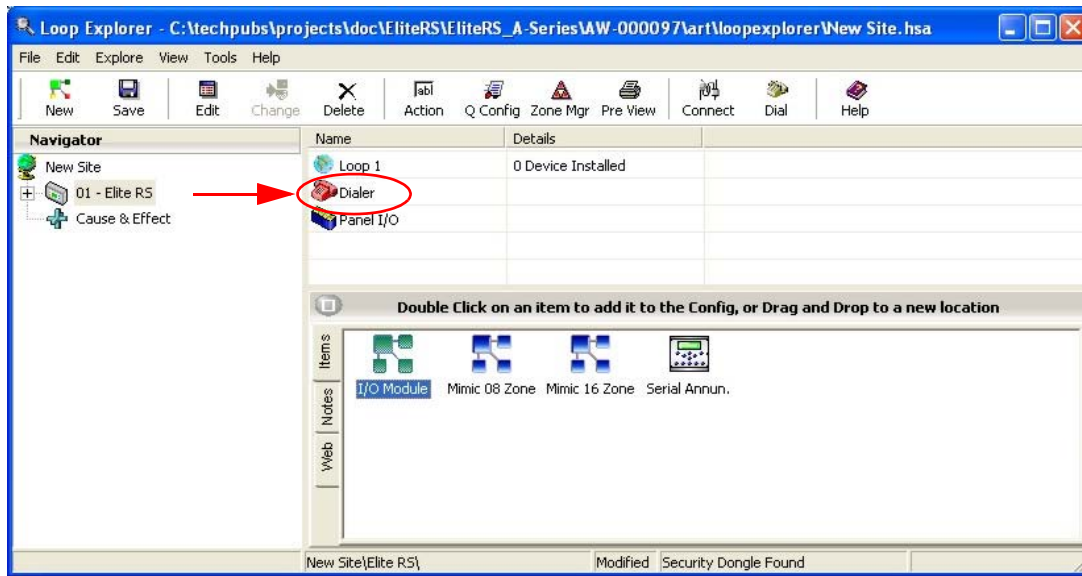

Double clicking on the dialer shown in Figure F-2 will bring you to the set-up screen illustrated in Figure F-3 and Figure F-4:

**Figure F-3
Configure Dialer Settings**

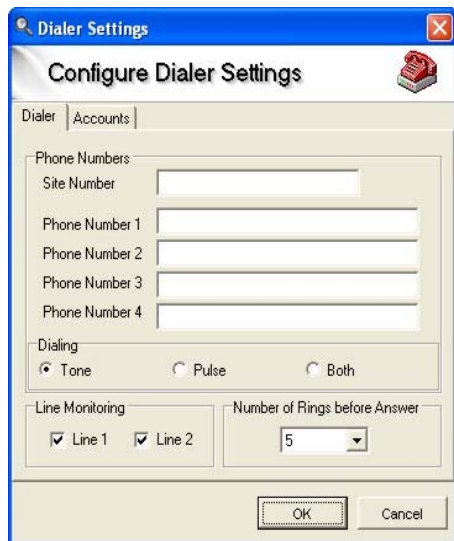

**Figure F-4
Configure Account Settings**

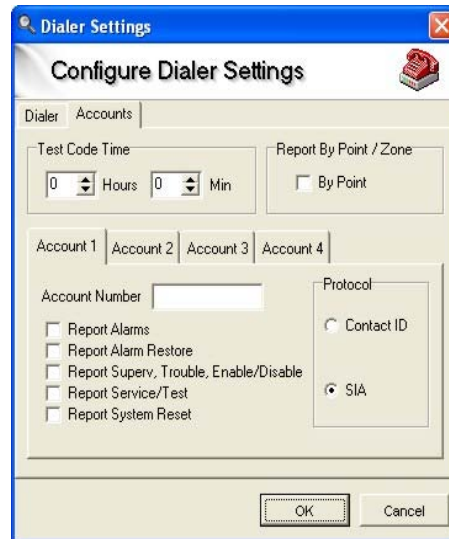

The **Dialer Tab** allows entry of information instructing the dialer how to call out and how to receive calls.

Phone Numbers

The embedded dialer allows a large array of reporting options based upon the setup options selected. Each of the phone number uses is explained below. In the most typical applications only phone number 1, or 1 & 2 are used. Each of the lines should be terminated by a RJ31X jack at the Control panel. Each of the lines should also be wired for loop start operation.

- Site Number** This is an optional field. If populated, this would be the telephone number of Line #1 connected to the RS Panel. This number would be dialed by Loop Explorer if a remote communication session from your PC was desired.

- Phone Number 1** This is the phone number of your monitoring center. Dialing modifiers may be used in the string (for example, = pause), although any modifiers must be valid for both telephone lines.

- Phone Number 2** Can be used for two purposes. The backup telephone number of your monitoring center (select backup reporting) and Redundant signal reporting.

Reference Figure F-5 for the backup reporting selection.

- Phone Number 3** This is the phone number used when redundant reporting is desired and Phone Number 2 is used for backup purposes.

- Phone Number 4** Can be used for two purposes. The backup telephone number of your monitoring center (select backup reporting) and Redundant signal reporting.

Reference Figure F-5 for the backup reporting selection.

Figure F-5 illustrates dialer configuration settings for the Account 2 tab:

Figure F-5
Account 2 tab

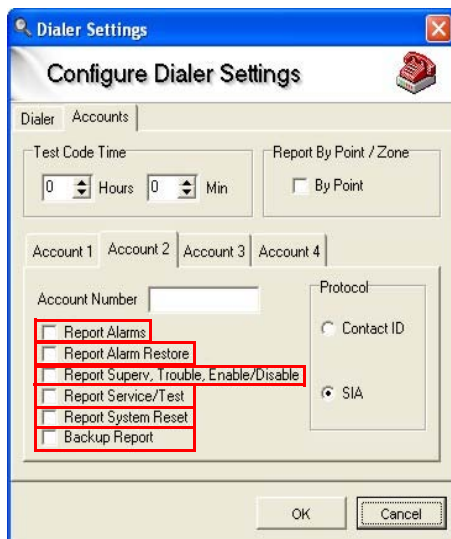

Dialing

Choose an option that would be used universally for both telephone lines; Tone, Pulse or Both. When 'both' is selected, the embedded dialer will attempt to dial touchtone and then attempt to dial using pulse if not successful.

Use Lines

Check the boxes for the phone lines which are active 1, 2 or both 1 & 2.

Voltage checks will only be conducted on those lines which are checked. Failure to check either line will result in no calls being made.

Number of rings before Answer

The capability for an incoming remote access call is available through the embedded dialer. Remote calls can only be answered on line #1. If no additional telephones are connected, the suggested value should be 2. If additional telephones are connected

Enter a value which will not cause conflict with other equipment on the telephone line.

The **Accounts Tab** allows entry of information instructing the dialer how to send data to the monitoring center.

Test Code Time

The embedded dialer will send a 24 hour test report signal based upon the test code time filled in within the Accounts tab of the configure dialer settings dialog. If the 4th reporting criteria (Report Service/Test) box is not enabled, no test signal will be generated.

Report By Zone or by Point

By Default signals are sent to the monitoring center by Zone. Checking this box will allow point reporting to occur.

Protocol

Choose the appropriate Protocol that you wish to transmit (SIA or Contact ID)

Account Number

Your monitoring center account number (4 digits in length). If contact ID this number should always be in Decimal, If SIA this number may be hexadecimal.

Reporting Criteria

By checking these boxes it is possible to alter the amount of information sent to the monitoring center. In a typical installation it would be recommended that boxes 1-4 be checked off.

Reference Figure F-5 for a typical installation example.

If the user would like to generate signals when the alarm silence or reset button have been activated, also check box 5 (typically you would not want to engage option 5, because of the additional traffic / calls which would be sent).

Within the account 2 & 4 tabs there is a sixth check box, Backup Report. This box should be checked if Account 2 is a backup telephone number for Account 1 or Account 4 is a backup telephone number for Account 3. The 'Backup Report' philosophy indicates that this number will only be tried if their compliments (1 & 3) do not reach the receiver.

Suspending Reporting

Incidents may arise where dialer configurations are calling an incorrect telephone number. While programming locally through Loop Explorer can directly and quickly correct this situation, sometimes panels are downloaded remotely. Waiting for the dialer to make many attempts to dial a bad telephone number before releasing the line can be time consuming.

By going into level 3 <Edit Configuration < Edit I/O < Set Remote Configuration <Enable, the panel will go into a trouble condition, and delete all messages queued for transmission. This procedure will allow line 1 to be free for an incoming call. The panel will remain in this trouble condition for 20 minutes or the receipt of a new configuration, whichever comes first.

All messages that were deleted when the remote configuration mode was entered will never be sent to the monitoring center, although these signals are stored in the event history log of the panel.

This page intentionally left blank.

Appendix G

Reporting Formats

This section describes reporting formats on the eLAN-RS Panel for SIA point conversion, Contact ID conversion and Event Code translation.

SIA Point Conversion

Logical Point # [Loop-Point-SubPoint]	Point Definition	Monitoring Point # Received in SIA	Monitoring Point # Received in SIA if sub point 1 used	Monitoring Point # Received in SIA if sub point 2 used	Monitoring Point # Received in SIA if sub point 3 used
Panel Output	NAC 1 Fault	0140			
Panel Output	NAC 2 Fault	0150			
Panel Input	Programmable Function	00A0			
Panel Input	Fire Drill	0090			
Panel Input	Reset	00B0			
Panel Input	Alarm Silence	00C0			
1-01-0	User Defined	1010	1011	1012	1013
1-02-0	User Defined	1020	1021	1022	1023
1-03-0	User Defined	1030	1031	1032	1033
1-04-0	User Defined	1040	1041	1042	1043
1-05-0	User Defined	1050	1051	1052	1053
1-06-0	User Defined	1060	1061	1062	1063
1-07-0	User Defined	1070	1071	1072	1073
1-08-0	User Defined	1080	1081	1082	1083
1-09-0	User Defined	1090	1091	1092	1093
1-10-0	User Defined	10A0	10A1	10A2	10A3
1-11-0	User Defined	10B0	10B1	10B2	10B3
1-12-0	User Defined	10C0	10C1	10C2	10C3

Logical Point # [Loop-Point-SubPoint]	Point Definition	Monitoring Point # Received in SIA	Monitoring Point # Received in SIA if sub point 1 used	Monitoring Point # Received in SIA if sub point 2 used	Monitoring Point # Received in SIA if sub point 3 used
1-13-0	User Defined	10D0	10D1	10D2	10D3
1-14-0	User Defined	10E0	10E1	10E2	10E3
1-15-0	User Defined	10F0	10F1	10F2	10F3
1-16-0	User Defined	1100	1101	1102	1103
1-17-0	User Defined	1110	1111	1112	1113
1-18-0	User Defined	1120	1121	1122	1123
1-19-0	User Defined	1130	1131	1132	1133
1-20-0	User Defined	1140	1141	1142	1143
1-21-0	User Defined	1150	1151	1152	1153
1-22-0	User Defined	1160	1161	1162	1163
1-23-0	User Defined	1170	1171	1172	1173
1-24-0	User Defined	1180	1181	1182	1183
1-25-0	User Defined	1190	1191	1192	1193
1-26-0	User Defined	11A0	11A1	11A2	11A3
1-27-0	User Defined	11B0	11B1	11B2	11B3
1-28-0	User Defined	11C0	11C1	11C2	11C3
1-29-0	User Defined	11D0	11D1	11D2	11D3
1-30-0	User Defined	11E0	11E1	11E2	11E3
1-31-0	User Defined	11F0	11F1	11F2	11F3
1-32-0	User Defined	1200	1201	1202	1203
1-33-0	User Defined	1210	1211	1212	1213
1-34-0	User Defined	1220	1221	1222	1223
1-35-0	User Defined	1230	1231	1232	1233

Logical Point # [Loop-Point-SubPoint]	Point Definition	Monitoring Point # Received in SIA	Monitoring Point # Received in SIA if sub point 1 used	Monitoring Point # Received in SIA if sub point 2 used	Monitoring Point # Received in SIA if sub point 3 used
1-36-0	User Defined	1240	1241	1242	1243
1-37-0	User Defined	1250	1251	1252	1253
1-38-0	User Defined	1260	1261	1262	1263
1-39-0	User Defined	1270	1271	1272	1273
1-40-0	User Defined	1280	1281	1282	1283
1-41-0	User Defined	1290	1291	1292	1293
1-42-0	User Defined	12A0	12A1	12A2	12A3
1-43-0	User Defined	12B0	12B1	12B2	12B3
1-44-0	User Defined	12C0	12C1	12C2	12C3
1-45-0	User Defined	12D0	12D1	12D2	12D3
1-46-0	User Defined	12E0	12E1	12E2	12E3
1-47-0	User Defined	12F0	12F1	12F2	12F3
1-48-0	User Defined	1300	1301	1302	1303
1-49-0	User Defined	1310	1311	1312	1313
1-50-0	User Defined	1320	1321	1322	1323
1-51-0	User Defined	1330	1331	1332	1333
1-52-0	User Defined	1340	1341	1342	1343
1-53-0	User Defined	1350	1351	1352	1353
1-54-0	User Defined	1360	1361	1362	1363
1-55-0	User Defined	1370	1371	1372	1373
1-56-0	User Defined	1380	1381	1382	1383
1-57-0	User Defined	1390	1391	1392	1393
1-58-0	User Defined	13A0	13A1	13A2	13A3

Logical Point # [Loop-Point-SubPoint]	Point Definition	Monitoring Point # Received in SIA	Monitoring Point # Received in SIA if sub point 1 used	Monitoring Point # Received in SIA if sub point 2 used	Monitoring Point # Received in SIA if sub point 3 used
1-59-0	User Defined	13B0	13B1	13B2	13B3
1-60-0	User Defined	13C0	13C1	13C2	13C3
1-61-0	User Defined	13D0	13D1	13D2	13D3
1-62-0	User Defined	13E0	13E1	13E2	13E3
1-63-0	User Defined	13F0	13F1	13F2	13F3
1-64-0	User Defined	1400	1401	1402	1403
1-65-0	User Defined	1410	1411	1412	1413
1-66-0	User Defined	1420	1421	1422	1423
1-67-0	User Defined	1430	1431	1432	1433
1-68-0	User Defined	1440	1441	1442	1443
1-69-0	User Defined	1450	1451	1452	1453
1-70-0	User Defined	1460	1461	1462	1463
1-71-0	User Defined	1470	1471	1472	1473
1-72-0	User Defined	1480	1481	1482	1483
1-73-0	User Defined	1490	1491	1492	1493
1-74-0	User Defined	14A0	14A1	14A2	14A3
1-75-0	User Defined	14B0	14B1	14B2	14B3
1-76-0	User Defined	14C0	14C1	14C2	14C3
1-77-0	User Defined	14D0	14D1	14D2	14D3
1-78-0	User Defined	14E0	14E1	14E2	14E3
1-79-0	User Defined	14F0	14F1	14F2	14F3
1-80-0	User Defined	1500	1501	1502	1503
1-81-0	User Defined	1510	1511	1512	1513

Logical Point # [Loop-Point-SubPoint]	Point Definition	Monitoring Point # Received in SIA	Monitoring Point # Received in SIA if sub point 1 used	Monitoring Point # Received in SIA if sub point 2 used	Monitoring Point # Received in SIA if sub point 3 used
1-82-0	User Defined	1520	1521	1522	1523
1-83-0	User Defined	1530	1531	1532	1533
1-84-0	User Defined	1540	1541	1542	1543
1-85-0	User Defined	1550	1551	1552	1553
1-86-0	User Defined	1560	1561	1562	1563
1-87-0	User Defined	1570	1571	1572	1573
1-88-0	User Defined	1580	1581	1582	1583
1-89-0	User Defined	1590	1591	1592	1593
1-90-0	User Defined	15A0	15A1	15A2	15A3
1-91-0	User Defined	15B0	15B1	15B2	15B3
1-92-0	User Defined	15C0	15C1	15C2	15C3
1-93-0	User Defined	15D0	15D1	15D2	15D3
1-94-0	User Defined	15E0	15E1	15E2	15E3
1-95-0	User Defined	15F0	15F1	15F2	15F3
1-96-0	User Defined	1600	1601	1602	1603
1-97-0	User Defined	1610	1611	1612	1613
1-98-0	User Defined	1620	1621	1622	1623
1-99-0	User Defined	1630	1631	1632	1633
1-100-0	User Defined	1640	1641	1642	1643
1-101-0	User Defined	1650	1651	1652	1653
1-102-0	User Defined	1660	1661	1662	1663
1-103-0	User Defined	1670	1671	1672	1673
1-104-0	User Defined	1680	1681	1682	1683

Logical Point # [Loop-Point-SubPoint]	Point Definition	Monitoring Point # Received in SIA	Monitoring Point # Received in SIA if sub point 1 used	Monitoring Point # Received in SIA if sub point 2 used	Monitoring Point # Received in SIA if sub point 3 used
1-105-0	User Defined	1690	1691	1692	1693
1-106-0	User Defined	16A0	16A1	16A2	16A3
1-107-0	User Defined	16B0	16B1	16B2	16B3
1-108-0	User Defined	16C0	16C1	16C2	16C3
1-109-0	User Defined	16D0	16D1	16D2	16D3
1-110-0	User Defined	16E0	16E1	16E2	16E3
1-111-0	User Defined	16F0	16F1	16F2	16F3
1-112-0	User Defined	1700	1701	1702	1703
1-113-0	User Defined	1710	1711	1712	1713
1-114-0	User Defined	1720	1721	1722	1723
1-115-0	User Defined	1730	1731	1732	1733
1-116-0	User Defined	1740	1741	1742	1743
1-117-0	User Defined	1750	1751	1752	1753
1-118-0	User Defined	1760	1761	1762	1763
1-119-0	User Defined	1770	1771	1772	1773
1-120-0	User Defined	1780	1781	1782	1783
1-121-0	User Defined	1790	1791	1792	1793
1-122-0	User Defined	17A0	17A1	17A2	17A3
1-123-0	User Defined	17B0	17B1	17B2	17B3
1-124-0	User Defined	17C0	17C1	17C2	17C3
1-125-0	User Defined	17D0	17D1	17D2	17D3
1-126-0	User Defined	17E0	17E1	17E2	17E3
2-01-0	User Defined	2010	2011	2012	2013

Logical Point # [Loop-Point-SubPoint]	Point Definition	Monitoring Point # Received in SIA	Monitoring Point # Received in SIA if sub point 1 used	Monitoring Point # Received in SIA if sub point 2 used	Monitoring Point # Received in SIA if sub point 3 used
2-02-0	User Defined	2020	2021	2022	2023
2-03-0	User Defined	2030	2031	2032	2033
2-04-0	User Defined	2040	2041	2042	2043
2-05-0	User Defined	2050	2051	2052	2053
2-06-0	User Defined	2060	2061	2062	2063
2-07-0	User Defined	2070	2071	2072	2073
2-08-0	User Defined	2080	2081	2082	2083
2-09-0	User Defined	2090	2091	2092	2093
2-10-0	User Defined	20A0	20A1	20A2	20A3
2-11-0	User Defined	20B0	20B1	20B2	20B3
2-12-0	User Defined	20C0	20C1	20C2	20C3
2-13-0	User Defined	20D0	20D1	20D2	20D3
2-14-0	User Defined	20E0	20E1	20E2	20E3
2-15-0	User Defined	20F0	20F1	20F2	20F3
2-16-0	User Defined	2100	2101	2102	2103
2-17-0	User Defined	2110	2111	2112	2113
2-18-0	User Defined	2120	2121	2122	2123
2-19-0	User Defined	2130	2131	2132	2133
2-20-0	User Defined	2140	2141	2142	2143
2-21-0	User Defined	2150	2151	2152	2153
2-22-0	User Defined	2160	2161	2162	2163
2-23-0	User Defined	2170	2171	2172	2173
2-24-0	User Defined	2180	2181	2182	2183

Logical Point # [Loop-Point-SubPoint]	Point Definition	Monitoring Point # Received in SIA	Monitoring Point # Received in SIA if sub point 1 used	Monitoring Point # Received in SIA if sub point 2 used	Monitoring Point # Received in SIA if sub point 3 used
2-25-0	User Defined	2190	2191	2192	2193
2-26-0	User Defined	21A0	21A1	21A2	21A3
2-27-0	User Defined	21B0	21B1	21B2	21B3
2-28-0	User Defined	21C0	21C1	21C2	21C3
2-29-0	User Defined	21D0	21D1	21D2	21D3
2-30-0	User Defined	21E0	21E1	21E2	21E3
2-31-0	User Defined	21F0	21F1	21F2	21F3
2-32-0	User Defined	2200	2201	2202	2203
2-33-0	User Defined	2210	2211	2212	2213
2-34-0	User Defined	2220	2221	2222	2223
2-35-0	User Defined	2230	2231	2232	2233
2-36-0	User Defined	2240	2241	2242	2243
2-37-0	User Defined	2250	2251	2252	2253
2-38-0	User Defined	2260	2261	2262	2263
2-39-0	User Defined	2270	2271	2272	2273
2-40-0	User Defined	2280	2281	2282	2283
2-41-0	User Defined	2290	2291	2292	2293
2-42-0	User Defined	22A0	22A1	22A2	22A3
2-43-0	User Defined	22B0	22B1	22B2	22B3
2-44-0	User Defined	22C0	22C1	22C2	22C3
2-45-0	User Defined	22D0	22D1	22D2	22D3
2-46-0	User Defined	22E0	22E1	22E2	22E3
2-47-0	User Defined	22F0	22F1	22F2	22F3

Logical Point # [Loop-Point-SubPoint]	Point Definition	Monitoring Point # Received in SIA	Monitoring Point # Received in SIA if sub point 1 used	Monitoring Point # Received in SIA if sub point 2 used	Monitoring Point # Received in SIA if sub point 3 used
2-48-0	User Defined	2300	2301	2302	2303
2-49-0	User Defined	2310	2311	2312	2313
2-50-0	User Defined	2320	2321	2322	2323
2-51-0	User Defined	2330	2331	2332	2333
2-52-0	User Defined	2340	2341	2342	2343
2-53-0	User Defined	2350	2351	2352	2353
2-54-0	User Defined	2360	2361	2362	2363
2-55-0	User Defined	2370	2371	2372	2373
2-56-0	User Defined	2380	2381	2382	2383
2-57-0	User Defined	2390	2391	2392	2393
2-58-0	User Defined	23A0	23A1	23A2	23A3
2-59-0	User Defined	23B0	23B1	23B2	23B3
2-60-0	User Defined	23C0	23C1	23C2	23C3
2-61-0	User Defined	23D0	23D1	23D2	23D3
2-62-0	User Defined	23E0	23E1	23E2	23E3
2-63-0	User Defined	23F0	23F1	23F2	23F3
2-64-0	User Defined	2400	2401	2402	2403
2-65-0	User Defined	2410	2411	2412	2413
2-66-0	User Defined	2420	2421	2422	2423
2-67-0	User Defined	2430	2431	2432	2433
2-68-0	User Defined	2440	2441	2442	2443
2-69-0	User Defined	2450	2451	2452	2453
2-70-0	User Defined	2460	2461	2462	2463

Logical Point # [Loop-Point-SubPoint]	Point Definition	Monitoring Point # Received in SIA	Monitoring Point # Received in SIA if sub point 1 used	Monitoring Point # Received in SIA if sub point 2 used	Monitoring Point # Received in SIA if sub point 3 used
2-71-0	User Defined	2470	2471	2472	2473
2-72-0	User Defined	2480	2481	2482	2483
2-73-0	User Defined	2490	2491	2492	2493
2-74-0	User Defined	24A0	24A1	24A2	24A3
2-75-0	User Defined	24B0	24B1	24B2	24B3
2-76-0	User Defined	24C0	24C1	24C2	24C3
2-77-0	User Defined	24D0	24D1	24D2	24D3
2-78-0	User Defined	24E0	24E1	24E2	24E3
2-79-0	User Defined	24F0	24F1	24F2	24F3
2-80-0	User Defined	2500	2501	2502	2503
2-81-0	User Defined	2510	2511	2512	2513
2-82-0	User Defined	2520	2521	2522	2523
2-83-0	User Defined	2530	2531	2532	2533
2-84-0	User Defined	2540	2541	2542	2543
2-85-0	User Defined	2550	2551	2552	2553
2-86-0	User Defined	2560	2561	2562	2563
2-87-0	User Defined	2570	2571	2572	2573
2-88-0	User Defined	2580	2581	2582	2583
2-89-0	User Defined	2590	2591	2592	2593
2-90-0	User Defined	25A0	25A1	25A2	25A3
2-91-0	User Defined	25B0	25B1	25B2	25B3
2-92-0	User Defined	25C0	25C1	25C2	25C3
2-93-0	User Defined	25D0	25D1	25D2	25D3

Logical Point # [Loop-Point-SubPoint]	Point Definition	Monitoring Point # Received in SIA	Monitoring Point # Received in SIA if sub point 1 used	Monitoring Point # Received in SIA if sub point 2 used	Monitoring Point # Received in SIA if sub point 3 used
2-94-0	User Defined	25E0	25E1	25E2	25E3
2-95-0	User Defined	25F0	25F1	25F2	25F3
2-96-0	User Defined	2600	2601	2602	2603
2-97-0	User Defined	2610	2611	2612	2613
2-98-0	User Defined	2620	2621	2622	2623
2-99-0	User Defined	2630	2631	2632	2633
2-100-0	User Defined	2640	2641	2642	2643
2-101-0	User Defined	2650	2651	2652	2653
2-102-0	User Defined	2660	2661	2662	2663
2-103-0	User Defined	2670	2671	2672	2673
2-104-0	User Defined	2680	2681	2682	2683
2-105-0	User Defined	2690	2691	2692	2693
2-106-0	User Defined	26A0	26A1	26A2	26A3
2-107-0	User Defined	26B0	26B1	26B2	26B3
2-108-0	User Defined	26C0	26C1	26C2	26C3
2-109-0	User Defined	26D0	26D1	26D2	26D3
2-110-0	User Defined	26E0	26E1	26E2	26E3
2-111-0	User Defined	26F0	26F1	26F2	26F3
2-112-0	User Defined	2700	2701	2702	2703
2-113-0	User Defined	2710	2711	2712	2713
2-114-0	User Defined	2720	2721	2722	2723
2-115-0	User Defined	2730	2731	2732	2733
2-116-0	User Defined	2740	2741	2742	2743

Logical Point # [Loop-Point-SubPoint]	Point Definition	Monitoring Point # Received in SIA	Monitoring Point # Received in SIA if sub point 1 used	Monitoring Point # Received in SIA if sub point 2 used	Monitoring Point # Received in SIA if sub point 3 used
2-117-0	User Defined	2750	2751	2752	2753
2-118-0	User Defined	2760	2761	2762	2763
2-119-0	User Defined	2770	2771	2772	2773
2-120-0	User Defined	2780	2781	2782	2783
2-121-0	User Defined	2790	2791	2792	2793
2-122-0	User Defined	27A0	27A1	27A2	27A3
2-123-0	User Defined	27B0	27B1	27B2	27B3
2-124-0	User Defined	27C0	27C1	27C2	27C3
2-125-0	User Defined	27D0	27D1	27D2	27D3
2-126-0	User Defined	27E0	27E1	27E2	27E3

Contact ID Conversion

Logical Point # [Loop-Point-SubPoint]	Point Definition	Monitoring Point # Received in Contact ID
Panel Output	NAC 1 Fault	020
Panel Output	NAC 2 Fault	021
Panel Input	Programmable Function	010
Panel Input	Fire Drill	009
Panel Input	Reset	011
Panel Input	Alarm Silence	012
1-01-0	User Defined	101
1-02-0	User Defined	102
1-03-0	User Defined	103
1-04-0	User Defined	104

Logical Point # [Loop-Point-SubPoint]	Point Definition	Monitoring Point # Received in Contact ID
1-05-0	User Defined	105
1-06-0	User Defined	106
1-07-0	User Defined	107
1-08-0	User Defined	108
1-09-0	User Defined	109
1-10-0	User Defined	110
1-11-0	User Defined	111
1-12-0	User Defined	112
1-13-0	User Defined	113
1-14-0	User Defined	114
1-15-0	User Defined	115
1-16-0	User Defined	116
1-17-0	User Defined	117
1-18-0	User Defined	118
1-19-0	User Defined	119
1-20-0	User Defined	120
1-21-0	User Defined	121
1-22-0	User Defined	122
1-23-0	User Defined	123
1-24-0	User Defined	124
1-25-0	User Defined	125
1-26-0	User Defined	126
1-27-0	User Defined	127
1-28-0	User Defined	128

Logical Point # [Loop-Point-SubPoint]	Point Definition	Monitoring Point # Received in Contact ID
1-29-0	User Defined	129
1-30-0	User Defined	130
1-31-0	User Defined	131
1-32-0	User Defined	132
1-33-0	User Defined	133
1-34-0	User Defined	134
1-35-0	User Defined	135
1-36-0	User Defined	136
1-37-0	User Defined	137
1-38-0	User Defined	138
1-39-0	User Defined	139
1-40-0	User Defined	140
1-41-0	User Defined	141
1-42-0	User Defined	142
1-43-0	User Defined	143
1-44-0	User Defined	144
1-45-0	User Defined	145
1-46-0	User Defined	146
1-47-0	User Defined	147
1-48-0	User Defined	148
1-49-0	User Defined	149
1-50-0	User Defined	150
1-51-0	User Defined	151
1-52-0	User Defined	152
1-53-0	User Defined	153

Logical Point # [Loop-Point-SubPoint]	Point Definition	Monitoring Point # Received in Contact ID
1-54-0	User Defined	154
1-55-0	User Defined	155
1-56-0	User Defined	156
1-57-0	User Defined	157
1-58-0	User Defined	158
1-59-0	User Defined	159
1-60-0	User Defined	160
1-61-0	User Defined	161
1-62-0	User Defined	162
1-63-0	User Defined	163
1-64-0	User Defined	164
1-65-0	User Defined	165
1-66-0	User Defined	166
1-67-0	User Defined	167
1-68-0	User Defined	168
1-69-0	User Defined	169
1-70-0	User Defined	170
1-71-0	User Defined	171
1-72-0	User Defined	172
1-73-0	User Defined	173
1-74-0	User Defined	174
1-75-0	User Defined	175
1-76-0	User Defined	176
1-77-0	User Defined	177
1-78-0	User Defined	178

Logical Point # [Loop-Point-SubPoint]	Point Definition	Monitoring Point # Received in Contact ID
1-79-0	User Defined	179
1-80-0	User Defined	180
1-81-0	User Defined	181
1-82-0	User Defined	182
1-83-0	User Defined	183
1-84-0	User Defined	184
1-85-0	User Defined	185
1-86-0	User Defined	186
1-87-0	User Defined	187
1-88-0	User Defined	188
1-89-0	User Defined	189
1-90-0	User Defined	190
1-91-0	User Defined	191
1-92-0	User Defined	192
1-93-0	User Defined	193
1-94-0	User Defined	194
1-95-0	User Defined	195
1-96-0	User Defined	196
1-97-0	User Defined	197
1-98-0	User Defined	198
1-99-0	User Defined	199
1-100-0	User Defined	110
1-101-0	User Defined	110
1-102-0	User Defined	110
1-103-0	User Defined	110

Logical Point # [Loop-Point-SubPoint]	Point Definition	Monitoring Point # Received in Contact ID
1-104-0	User Defined	110
1-105-0	User Defined	110
1-106-0	User Defined	110
1-107-0	User Defined	110
1-108-0	User Defined	110
1-109-0	User Defined	110
1-110-0	User Defined	111
1-111-0	User Defined	111
1-112-0	User Defined	111
1-113-0	User Defined	111
1-114-0	User Defined	111
1-115-0	User Defined	111
1-116-0	User Defined	111
1-117-0	User Defined	111
1-118-0	User Defined	111
1-119-0	User Defined	111
1-120-0	User Defined	112
1-121-0	User Defined	112
1-122-0	User Defined	112
1-123-0	User Defined	112
1-124-0	User Defined	112
1-125-0	User Defined	112
1-126-0	User Defined	112
2-01-0	User Defined	201
2-02-0	User Defined	202

Logical Point # [Loop-Point-SubPoint]	Point Definition	Monitoring Point # Received in Contact ID
2-03-0	User Defined	203
2-04-0	User Defined	204
2-05-0	User Defined	205
2-06-0	User Defined	206
2-07-0	User Defined	207
2-08-0	User Defined	208
2-09-0	User Defined	209
2-10-0	User Defined	210
2-11-0	User Defined	211
2-12-0	User Defined	212
2-13-0	User Defined	213
2-14-0	User Defined	214
2-15-0	User Defined	215
2-16-0	User Defined	216
2-17-0	User Defined	217
2-18-0	User Defined	218
2-19-0	User Defined	219
2-20-0	User Defined	220
2-21-0	User Defined	221
2-22-0	User Defined	222
2-23-0	User Defined	223
2-24-0	User Defined	224
2-25-0	User Defined	225
2-26-0	User Defined	226
2-27-0	User Defined	227

Logical Point # [Loop-Point-SubPoint]	Point Definition	Monitoring Point # Received in Contact ID
2-28-0	User Defined	228
2-29-0	User Defined	229
2-30-0	User Defined	230
2-31-0	User Defined	231
2-32-0	User Defined	232
2-33-0	User Defined	233
2-34-0	User Defined	234
2-35-0	User Defined	235
2-36-0	User Defined	236
2-37-0	User Defined	237
2-38-0	User Defined	238
2-39-0	User Defined	239
2-40-0	User Defined	240
2-41-0	User Defined	241
2-42-0	User Defined	242
2-43-0	User Defined	243
2-44-0	User Defined	244
2-45-0	User Defined	245
2-46-0	User Defined	246
2-47-0	User Defined	247
2-48-0	User Defined	248
2-49-0	User Defined	249
2-50-0	User Defined	250
2-51-0	User Defined	251
2-52-0	User Defined	252

Logical Point # [Loop-Point-SubPoint]	Point Definition	Monitoring Point # Received in Contact ID
2-53-0	User Defined	253
2-54-0	User Defined	254
2-55-0	User Defined	255
2-56-0	User Defined	256
2-57-0	User Defined	257
2-58-0	User Defined	258
2-59-0	User Defined	259
2-60-0	User Defined	260
2-61-0	User Defined	261
2-62-0	User Defined	262
2-63-0	User Defined	263
2-64-0	User Defined	264
2-65-0	User Defined	265
2-66-0	User Defined	266
2-67-0	User Defined	267
2-68-0	User Defined	268
2-69-0	User Defined	269
2-70-0	User Defined	270
2-71-0	User Defined	271
2-72-0	User Defined	272
2-73-0	User Defined	273
2-74-0	User Defined	274
2-75-0	User Defined	275
2-76-0	User Defined	276
2-77-0	User Defined	277

Logical Point # [Loop-Point-SubPoint]	Point Definition	Monitoring Point # Received in Contact ID
2-78-0	User Defined	278
2-79-0	User Defined	279
2-80-0	User Defined	280
2-81-0	User Defined	281
2-82-0	User Defined	282
2-83-0	User Defined	283
2-84-0	User Defined	284
2-85-0	User Defined	285
2-86-0	User Defined	286
2-87-0	User Defined	287
2-88-0	User Defined	288
2-89-0	User Defined	289
2-90-0	User Defined	290
2-91-0	User Defined	291
2-92-0	User Defined	292
2-93-0	User Defined	293
2-94-0	User Defined	294
2-95-0	User Defined	295
2-96-0	User Defined	296
2-97-0	User Defined	297
2-98-0	User Defined	298
2-99-0	User Defined	299
2-100-0	User Defined	210
2-101-0	User Defined	210
2-102-0	User Defined	210

Logical Point # [Loop-Point-SubPoint]	Point Definition	Monitoring Point # Received in Contact ID
2-103-0	User Defined	210
2-104-0	User Defined	210
2-105-0	User Defined	210
2-106-0	User Defined	210
2-107-0	User Defined	210
2-108-0	User Defined	210
2-109-0	User Defined	210
2-110-0	User Defined	210
2-111-0	User Defined	211
2-112-0	User Defined	211
2-113-0	User Defined	211
2-114-0	User Defined	211
2-115-0	User Defined	211
2-116-0	User Defined	211
2-117-0	User Defined	211
2-118-0	User Defined	211
2-119-0	User Defined	211
2-120-0	User Defined	212
2-121-0	User Defined	212
2-122-0	User Defined	212
2-123-0	User Defined	212
2-124-0	User Defined	212
2-125-0	User Defined	212
2-126-0	User Defined	212

Event Code Translation

Input Action	Device Setting	SIA Event Reporting Code	SIA Event Restoring Code	Contact ID Reporting Code	Contact ID Restoring Code
Fire	Manual Pull Station	FA	FH	E110	R110
	Waterflow Alarm	SA	SH	E113	R113
	Duct Detector	FA	FH	E110	R110
	Detector	FA	FH	E110	R110
	General Purpose N/O EOL	FA	FH	E110	R110
	General Purpose N/C EOL	FA	FH	E110	R110
	General Purpose N/C no EOL	FA	FH	E110	R110
	Waterflow Alarm N/S	SA	SH	E113	R113
	Fire Drill		FI	FK	E604
Trouble	General Purpose N/O EOL	FT	FJ	E373	R373
	General Purpose N/C EOL	FT	FJ	E373	R373
	General Purpose N/C no EOL	FT	FJ	E373	R373
PreAlarm	General Purpose N/O EOL	FT	FJ	E118	R118
	General Purpose N/C EOL	FT	FJ	E118	R118
	General Purpose N/C no EOL	FT	FJ	E118	R118

Input Action	Device Setting	SIA Event Reporting Code	SIA Event Restoring Code	Contact ID Reporting Code	Contact ID Restoring Code
Supervisory	Waterflow Alarm	FS	FV	E200	R200
	Valve Monitoring N/O EOL	SS	SR	E203	R203
	Valve Monitoring N/C EOL	SS	SR	E203	R203
	Duct Detector	SS	SR	E203	R203
	Detector	SS	SR	E203	R203
	Temperature	KS	KR	E203	R203
	Pressure	SS	SR	E203	R203
	Level	SS	SR	E203	R203
	Position	SS	SR	E203	R203
	Power	SS	SR	E203	R203
	General Supervision	SS	SR	E203	R203
	General Purpose N/O EOL	SS	SR	E203	R203
	General Purpose N/C EOL	SS	SR	E203	R203
	General Purpose N/C no EOL	SS	SR	E203	R203
Emergency	General Purpose N/O EOL	QA	QR	E150	R150
	General Purpose N/C EOL	QA	QR	E150	R150
	General Purpose N/C no EOL	QA	QR	E150	R150

Input Action	Device Setting	SIA Event Reporting Code	SIA Event Restoring Code	Contact ID Reporting Code	Contact ID Restoring Code
Auxiliary	General Purpose N/O EOL	IA	IR	E140	R140
	General Purpose N/C EOL	IA	IR	E140	R140
	General Purpose N/C no EOL	IA	IR	E140	R140
Security	General Purpose N/O EOL	BA	BH	E130	R130
	General Purpose N/C EOL	BA	BH	E130	R130
	General Purpose N/C no EOL	BA	BH	E130	R130
Silence	General Purpose N/O EOL	-	-	-	-
	General Purpose N/C EOL	-	-	-	-
	General Purpose N/C no EOL	-	-	-	-
Reset	General Purpose N/O EOL	-	-	-	-
	General Purpose N/C EOL	-	-	-	-
	General Purpose N/C no EOL	-	-	-	-

Input Action	Device Setting	SIA Event Reporting Code	SIA Event Restoring Code	Contact ID Reporting Code	Contact ID Restoring Code
Fire Drill	General Purpose N/O EOL	FI	FK	E604	R604
	General Purpose N/C EOL	FI	FK	E604	R604
	General Purpose N/C no EOL	FI	FK	E604	R604
Transparent	General Purpose N/O EOL	-	-	-	-
	General Purpose N/C EOL	-	-	-	-
	General Purpose N/C no EOL	-	-	-	-
Disablement	General Purpose N/O EOL	-	-	-	-
	General Purpose N/C EOL	-	-	-	-
	General Purpose N/C no EOL	-	-	-	-
Test Mode	General Purpose N/O EOL	-	-	-	-
	General Purpose N/C EOL	-	-	-	-
	General Purpose N/C no EOL	-	-	-	-

Input Action	Device Setting	SIA Event Reporting Code	SIA Event Restoring Code	Contact ID Reporting Code	Contact ID Restoring Code
Telco Line 1 Failure	Panel Action	LT	LR	E351	R351
Telco Line 2 Failure	Panel Action	LT	LR	E352	R352
AC Power Failure	Panel Action	AT	AR	E301	R301
Battery Missing	Panel Action	YM	YR	E311	R311
Low Battery	Panel Action	YT	YR	E302	R302
Earth Ground	Panel Action	YP	YQ	E310	R310
Panel Reboot	Panel Action	FT	FJ	E305	R305
SLC Loop 1 Open	Panel Action	ET	ER	E331	R331
SLC Loop 2 Open	Panel Action	ET	ER	E332	R332
Comm Fail 1	Panel Action	YC	YK	E354	R354
Comm Fail 2	Panel Action	YC	YK	E354	R354
Aux 24V fuse trouble	Panel Action	YP	YQ	E312	R312
Network Troubles (open circuit or short)	Panel Action	NT	NR	E330	R330
Troubles on RS-454 devices (missing addr5)	Panel Action	ET0450	ER0450	E330 069	R330 069
Troubles on RS-454 devices (unexpected addr4)	Panel Action	ET0440	ER0440	E330 068	R330 068
Test Signal		RP or RY		E602 or E608	-

Index

Numerics

5.25 Amp Power Supply 15

A

Access Level 2 49
 Access Level 3 54
 Access Level 3 controls 49
 Activates inputs, outputs or actions 12
 additional requirements 26
 Address restrictions 8
 addressable device 27
 Alarm Silence 12
 Alarm Silence button 12
 anchor the empty cabinet 20
 Anchoring 20
 anchoring the Elite-RS 20
 Audible Devices 30
 Authorized Special Application Devices 93
 Automatic-retry 15
 Auxiliary 24 VDC 101

B

Battery Cabinet 32
 battery disconnected 37
 Battery-backup 15
 Battery-boost 15
 battery-lead-kit 59
 before beginning the installation process 18

C

Cabling 69
 cancel disablements 52
 Cancels the current menu selection 11
 circuit overloads 59
 Class A, Style 6 26
 Class A, Style 6 compliance 28
 Class B connections 29
 Class B, Style Y Notification Appliances 31
 clearance beyond the door 19
 Clearing the Event Log 43
 Closed Nipple 27
 Closed Nipple devices 27
 closed-nippling 27
 common enclosure 27
 Compatible Devices for Auxiliary 24V 93
 Compatible Notification Appliance Circuits 77

Configures the Elite-RS Panel 34
 Confirming a Successful Installation 34
 Connect Class B loops 29
 Connecting 24VDC Devices 25
 Connecting Batteries 32
 Connecting Class A Loops 32
 Contact ID format 8
 Contacting VES for Repair 4
 contamination status 53
 Control Unit Board 65
 Current Draw Worksheet 95, 107

D

daylight saving time 53
 Denotes a displayed variable 4
 Details of the fire activation 54
 Detector Sensitivity 29
 Detector Spacing 29
 Determining 97
 Determining Battery Capacity 18
 device-loading 95
 digital communication format 8
 Disable 51
 Disable Addresses 51
 Disable Loops 50
 Disable Panel I/O 51
 Disable Zones 50
 Disablements Menu 50
 Disables or enables NAC 1 51
 Disables or enables NAC 2 51
 Disables or enables the front panel
 Programmable Function button 51
 Disables or enables the front-panel Fire Drill button .. 51
 disconnected-battery and low-battery indicators 57
 Displaying the Event Log 41
 Displays after a successful boot 34
 Displays the number of alarms present 11
 Displays the number of events present 11
 Document Conventions 4

E

electrostatic discharge	18
electrostatic discharge damage	18
Enables the menu selection	11
Enter	11
EVENT LOG	38
Event Log	41
event log	38
event log clear	38
Events and Status	53
Exit	11
expansion boards	32

F

field-programmable software	1
Fire	32
Fire Drill	12, 51
Fire Event	54
Fire warning NACs	54
Fire Zone indicator	54
front panel lamps	36
Front-Panel Menu	
Access Level 3	53
Disablements	50
Events and Status	53
Sensor Maintenance Early Warning	53
Set System Time	53
Test Zones	52
Fuse failure	59

G

General Trouble indicator	54
ground strap	18
Ground straps	18

H

heart-beat	57
help screen	11

I

if front panel lamps do not light	36
If You Need Help	
technical assistance contact	4
Indicates text displayed on a computer screen	4
industry-standard receivers	8
Initiate zone testing	52
Input Delay Settings	29
Inspecting Batteries	57
Installation	
Before you begin	18
Confirming a Successful Installation	34
Connecting Class B Loops	29
Connecting the Power Supply and Batteries	19
Event Log	41
Loop Data Test	45
NFPA 72, Style 6	29
NFPA 72, Style 7	27
TEST ZONES	38
Testing the Panel Lamps	36
Wiring AC Power and TELCO	20
Installation Procedures	25
installing audible and visual Notification Appliances	30
Installing SLC Devices	29
Installing the 10 Amp Battery-Fuse	59
Installing the 3 Amp Power Supply Fuse	60
Installing the Standby-Batteries	57
Introduction	1

K

knockout tabs	20
---------------	----

L

Lamp Test	12
lamp test button	36
LCD status display	54
Local NAC On – Off	52
Logon	17, 49
LOOP DATA TEST	38
Loop Initialization	34
Loop Outputs On – Off	52
Low battery voltage	37
low current auxiliary devices	32

M

maintain and repair	57
Maintenance	57
Marking the Location	19
maximum current draw	99
maximum line loss	32
maximum Pre-Alarm event delay	54
maximum resistance	100
maximum Trouble event delay	54
maximum wire length	99
minimum operating-voltage	99
monitoring and reporting	7
More Events	11
More Fire Events	11
Mounting Hardware	18
mounting site	18
Mutes the internal buzzer	12

N

NAC Circuit 1	51
NAC Circuit 2	51
NAC Trouble indicator	51
navigate down to TEST ZONES	39
Navigate the menu	49
Navigates menu selections down	11
Navigates menu selections to the left	11
Navigates menu selections to the right	11
Navigates menu selections up	11
NFPA 72, Class A, Style 7 requirements	27
non-latching inputs	12
Non-latching inputs are cleared	12
Normal Standby	35
normally-open contact	32
Normal-Standby	34, 35
Notification Appliance (NA)	30

O

Operating Environment	71
Overview	7
Panel Controls and Indicators	9

P

panel buzzer	54
Panel Initialization	34
Panel Outputs On – Off	52
Panel Sounder Silence	12
Part Numbers	4
Appendix B	4
Part numbers	
Appendix B	4
Appendix D	4
Physical Specifications	71
Planning	18
Points and addresses	7
points per loop	7
points per panel	7
polarized and suppressed circuits	32
Power-Supply	15
power-supply fuse	59
Pre-alarm Event	54
Preparation	17, 49
Preparing for Mounting	20
Programmable	51
Programmable Function	12
protect SLC loop devices	26
Provides a fire drill test	12

Q

qualified personnel	18
---------------------	----

R

raceways	27
Re Sound Alarm	12
red FIRE lamp	54
Related Documentation	3
Relay	32
Relay Contacts	32
Relay contacts	32
removes the event log	43
Removing Knockout Tabs	20
Removing the 10 Amp Battery-Fuse	59
Removing the 3 Amp Power Supply Fuse	60
Removing the Door	62
Removing the Standby-Batteries	57
Replacement Parts	76
replacement standby-batteries	58
Replacing Fuses	59
Replacing Standby-Batteries	57
Reporting	115
Reset	12
Reset button	12
Resets latching inputs	12
Riser conductors	92

S

Selecting Standby-Batteries	19
Sensor Maintenance Early Warning	53
sets the panel date and time	53
Short Circuit Isolator Modules	26
Short-circuit protection	15
SIA or Contact ID	8
Silence the sounder	37
Silences NACs connected to the Elite-RS	12
silencing operation	36
single housings	27
SLC	65
SLC detectors	29
SLC loop	26
SLC loop installation	30
Specifying Wire Size	25
Standard for Control Units and Accessories for Fire Alarm Systems	1
Status	15
status monitoring and reporting	8
Sub-addresses	51
sum of device-loads	95
Supervisory	32

T

termination jumpers	29
test example	47
Test Mode condition	52
TEST ZONES	38
Testing the Installation	20, 25
Tests	38
Tests Elite-RS Panel NACs	38
Tests front panel indicators and the internal buzzer	12
Tests internal hardware and firmware	34
Tests loop driven outputs	38
Timed disabling	51
To cancel disablements	52
To complete the installation	17
to comply with NFPA 72, Class A, Style 6 or Style 7	26
toggle disablements	52
total-current	95
Trouble	32
trouble condition	36
Trouble Event	54
trouble signal	26, 29
Troubleshooting	38
Trouble-Silence Test	36

U

upper control pad	38
used for emphasis	4
Using This Manual	3

V

variable that you must type	4
View & Restore Disabled Features	52
View / Restore Disablements option	52
View Devices	52
Visual Devices	30
voltage reversing outputs	32

W

wire length maximums	66
Writing styles	4

Z

zero-ohm shorting-jumpers	26, 29
---------------------------	--------

