

VS2 Intelligent Life Safety System



Overview

The Vigilant VS2 intelligent life safety system offers the speed of high-end intelligent processing in a configuration that delivers an uncomplicated solution for small to mid-sized applications. With intelligent detection, electronic addressing, automatic device mapping, optional Ethernet® connectivity, and a full line of easily-configured option cards and modules, this quick-to-install system offers versatility that benefits building owners and contractors alike.

The VS2 provides one Class A or Class B analog device loop that supports up to 250 device addresses. A second 250-point loop may be added to the VS2 to expand total system capacity to up to 500 device addresses. The panel includes four NACs that may be wired for either Class A or Class B operation.

This life safety system features an attractive contemporary design that fits with any decor. Its gently curved doorfront offers a distinctive flair with available red or silver finishes. Controls are discreetly inset behind a striking black bezel.

The VS2 supports a wide range of accessories and related equipment, including:

- Intelligent modules, detectors, and bases
- R-Series remote annunciators
- option cards that expand system capacity and extend system capabilities.
- Integrated Carbon Monoxide gas sensing with V-PCOS detectors including distinct audible signaling

Features

- Comes standard with one loop (expandable to two) that supports up to 250 (expandable to 500) intelligent devices: each VS2 loop supports up to 125 detectors and up to 125 modules.
- Four Class B NACs or two Class A NACs.
- Form C contacts for alarm and trouble, Form A for supervisory
- Electronic addressing with automatic device mapping
- Optional Ethernet port for diagnostics, programming and a variety of system reports
- Two programmable switches with LEDs and custom labeling
- Supports fire suppression routines with a dedicated intelligent releasing module
- Supports Genesis horn silence over two wires and UL 1971-compliant strobe synchronization
- Supports up to eight serial annunciators, (LCD, LED-only, and graphic interface).
- 1,000 event panel history log
- Can use existing wiring for most retrofit applications
- Supports V-Series single and multisensor detectors
- Upload/download remotely or locally
- Two-level maintenance alert reporting
- Pre-alarm and alarm verification by point
- Adjustable detector sensitivity
- 4 x 20 character backlit LCD display
- Optional earthquake hardening; OSHPD seismic pre-approval for component Importance Factor 1.5

Application

The VS2 life safety system is an easy-to-use intelligent solution for small to mid-sized buildings. Analog technology delivers the benefits of quick and uncomplicated system installation, while a clean and easy-to-operate user interface makes panel operation and system maintenance quick and intuitive.

The smart choice

Electronic addressing eliminates the tedium of setting dipswitches, and automatic device mapping ensures that each device resides on the system at its correct location. Meanwhile, innovative programming allows the designer to customize the system to precisely suit the needs of the building owner.

Versatility built right in

Two fully-programmable front panel switch/LED combinations provide an added measure of simplicity. Their slide-in labels take the mystery out of custom applications, and present a clean finished appearance.

Perfect for retrofits

The VS2 is particularly well-suited to retrofit applications. All connections are made over standard wiring – no shielded cable required. This means that in most situations existing wiring can be used to upgrade a legacy control panel to V-Series technology without the expense or disruption of rewiring the entire building.

Signals with a difference

VS2 NACs are configurable to fully support the advanced signaling capabilities of Edwards Genesis and Enhanced Integrity notification appliances. These devices offer precision synchronization of strobes to UL 1971 standards. For Genesis devices, enabling this feature allows connected horns to be silenced while strobes on the same two-wire circuit continue to flash until the panel is reset.

Clear-cut remote annunciation

Remote annunciation is a strong suit of the VS2. Up to eight annunciators can be installed on a single system. Compatible annunciators include a range of LED and LCD models that provide zone or point annunciation, as well as common control capabilities.

The VS2 also supports graphic annunciation with optional RA Graphic Annunciator interface modules. Each interface provides common control, indicators, and 32 LEDs. Consult the Ordering Information section for details.

A complete line of accessories

The VS2 life safety system is supported by a complete line of intelligent detectors, modules and related equipment. Consult the Ordering Information section for details.

Operation

The front panel provides an easy-to-use operator's interface, as well as all the necessary controls for front panel programming. A large back-lit 80-character LCD displays system status, event details, and programming prompts. Large tactile control buttons are easy to see in low light conditions, and bright multi-color LEDs offer at-a-glance status indication.

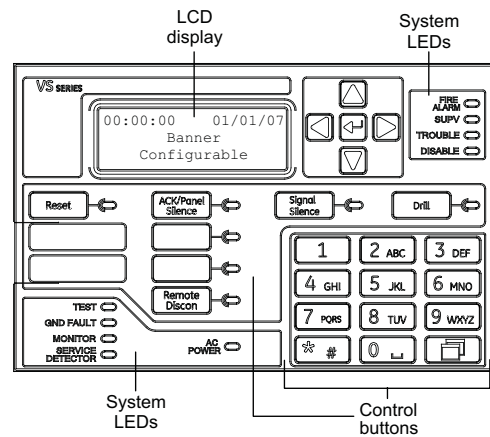

Control buttons

Button	Description
Reset	Initiates a system reset.
ACK/Panel Silence	Silences the panel and remote annunciators during an active trouble, supervisory, or alarm event and acknowledges new event activations.
Signal Silence	<i>Alarm mode:</i> Silences active notification appliances. Pressing Signal Silence a second time turns NACs back on.
Drill	Initiates a drill confirmation. Pressing drill a second time turns off the drill function.
Remote Disconnect	<i>Dialer:</i> Disables or enables dialer. <i>Dialer set to modem only:</i> Disables or enables the common alarm relay.
Left arrow	<i>Display mode:</i> Moves the cursor to the left. <i>Menu mode:</i> Toggles between programming selections.
Right arrow	<i>Display mode:</i> Moves the cursor to the right. <i>Menu mode:</i> Retrieves a programming option's sub menu and toggles between a programming option's selections.
Up arrow	<i>Display mode:</i> Advances to the previous event. <i>Menu mode:</i> Moves the cursor up.
Down arrow	<i>Display mode:</i> Advances to the next event. <i>Menu mode:</i> Moves the cursor down.
Enter	<i>Display mode:</i> Displays selected event details. <i>Menu mode:</i> Retrieves a programming option's sub menu or jumps to the Save function in the menu. <i>Entry mode:</i> Enters the selected data into the system.
Cancel	<i>Display mode:</i> Exits the detailed information display. <i>Menu mode:</i> Exits the current menu level. <i>Entry mode:</i> Clears the current entry.
Menu	<i>Display mode:</i> Enters the menu mode <i>Menu mode:</i> Exits menu mode
Space	Enters a space, such as a space between words.
Alphanumeric keypad	<i>Entry mode:</i> Pressing a button once enters the number on the button. Pressing the button twice enters the secondary value.
Programmable buttons	These buttons can be programmed to control outputs, disable devices or unlatch system outputs. The buttons can be labeled with a slip-in insert.

System LEDs

LED	Description
Alarm	Red LED. On steady when there is an active alarm.
Trouble	Yellow LED. Flashes when there is a fault on a monitored circuit or system component, or when a circuit is disabled.
Supv	Yellow LED. On steady when there is an active supervisory event.
AC Power	Green LED. On when the panel has AC power.
Disable	Yellow LED. Double-flashes when there is a disabled circuit or alarm relay.
Ground Fault	Yellow LED. On steady during an active ground fault.
Test	Yellow LED. Flashes when performing an audible walk test. Steady indicates a silent test.
Monitor	Yellow LED. On steady when there is an active monitor event.
Service Detector	Yellow LED. Indicates that detector needs servicing.
Signal Silence	Yellow LED. On steady indicates that NAC circuits are turned off but the panel is still in alarm.
Remote Disconnect	Yellow LED. On steady indicates that the dialer is disabled or that the alarm relay is enabled or disabled when the dialer is set to modem only.
Drill	Yellow LED. Indicates that the panel is in drill.
Reset	Yellow LED. Indicates that the panel is resetting.
Panel Silence	Yellow LED. Indicates that the panel has been silenced during an active trouble, supervisory, or alarm event and indicates that new event activations have been acknowledged.
User keys	Yellow LED. Programmable.

Panel Operation Options

Language	English or French
Marketplace	U.S. or Canada
AC fail delay	<i>Off:</i> Off-premise notification of an AC power failure is immediate. <i>1 to 15 hours:</i> Delays the off-premise notification of an AC power failure by the time period selected.
Zone resound	<i>On:</i> NACs resound each time a device in the zone goes into alarm even if they were silenced <i>Off:</i> Inhibits the NACs from turning on again (after they were silenced) when a second device in the zone goes into alarm.
Reset inhibit after NACs turn on	<i>Off:</i> Panel reset is operational immediately. <i>1 minute:</i> Panel reset is inhibited for one minute.
Auto signal silence	<i>Off:</i> Allows immediate silencing of signals from an off-normal condition using the Signal Silence button <i>5 to 30 minutes:</i> Delays the silencing of signals from an off-normal condition by disabling the Signal Silence button for the time period selected.
Day start	Start time for daytime sensitivity
Night start	Start time for nighttime sensitivity
Date	MM/DD/YYYY, DD/MM/YYYY
Sounder Base	Six configuration settings
Mapping	<i>Disabled:</i> Device mapping is not available <i>Enabled:</i> Device mapping is available
LCD banner	Banner text for line one and line two. Each line is capable of up to 20 characters.
Event notification	<i>Zone:</i> When a device is a member of a zone, only the zone information is sent to the LCD display, LEDs, printer, and dialer. <i>Zone/device:</i> Zone information is sent to the LCD display and LEDs. Device information is sent to the printer and dialer. <i>Device:</i> Only device information is reported.

Programming

V-Series panels are simple to set up, quick to program, and easy to maintain. The auto programming feature quickly gets the panel operational using factory default settings. Basic zone and point settings can be programmed easily through the front panel interface, so the system is up and running in no time.

For more advanced system configuration and correlation groups programming, V-Series panels interface to a PC running compatible VS-CU software. This option offers full system configuration in the familiar Windows® operating environment. Connection is typically made to a laptop through the panel's optional RS-232 communications port, which can also be used to connect a system printer.

Among the many innovations of the VS2 control panel is the optional network card. This module provides a standard 10/100 Base T Ethernet® network connection that permits access to the control panel from any remote location with the correct communications protocols. The connection can be used to download to the panel from the VS-CU, or upload and view system reports using the VS-CU.

Available system reports include:

- Correlation groups
- Device maintenance
- Internal status
- System status
- Dialer
- Device details
- History
- System configuration
- Walk test
- CO Runtime

Dimensions

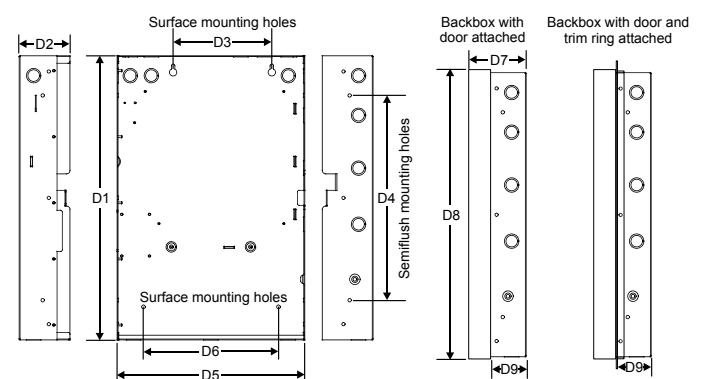

Backbox and backbox with door

D1*	D2	D3	D4	D5*	D6	D7	D8	D9
28.0"	3.85"	9.0"	22.0"	15.75"	10.25"	3.9"	28.2"	2.7"
71.1cm	9.8cm	22.8cm	55.8cm	40.0cm	26.0cm	9.9cm	71.6cm	6.8cm

* Add 1-1/2 in. (3.81 cm) to D1 and D5 dimensions for trim kit.

Wiring & Configuration

Notification appliance circuits (TB2)

V-Series control panels come equipped with two notification appliance circuits. Each circuit can be individually configured for continuous, temporal, synchronized, latching, and coded output.

Circuit specifications

Circuit Type	4 Class B or 2 Class A, 2.5 amps each
Voltage	24 VFWR
Current	6.0 A total, 2.5 A max. per circuit at 120/230 VAC 60 Hz 5.0 A total at 230VAC 50 Hz 2.5 A max. per circuit
Impedance	26 Ω total, 0.35 μF max
EOLR	15 K Ω, ½ W

Class B wiring

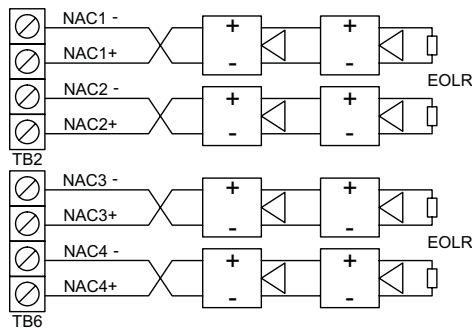

Marking indicates output signal polarity when the circuit is active. Polarity reverses when the circuit is not active. Wire notification appliances accordingly. Notification appliance polarity shown in active state.

Class A wiring

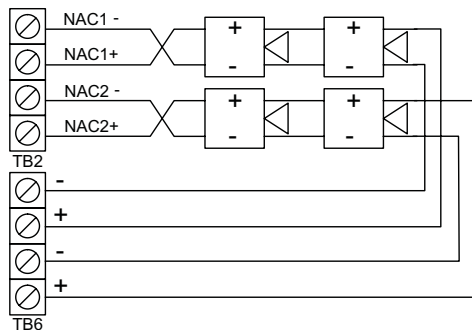

Auxiliary & Smoke power outputs (TB3)

The control panel provides two auxiliary power outputs which can be used for powering ancillary equipment such as remote annunciators and two wire smoke detectors. Aux 2 can be software selected to operate continuous. The circuit is supervised for shorts and grounds.

Note: For a complete list of devices that can be connected to this circuit, refer to the VS Series Compatibility List.

Circuit specifications

Circuit voltage range	21.9 to 28.3 V
Resettable circuit (Aux power 2)	24 VDC nominal at 500 mA
Continuous circuit (Aux power 1)	24 VDC nominal at 500 mA. Use this circuit for powering two-wire smoke detectors.

Note: Any current above 0.5 amp connected to both Aux 1 and 2 will reduce the total available NAC power by that amount.

Device loop

The system provides one device loop circuit with a total capacity of 125 detectors and 125 module addresses. The loop circuit is supervised for opens, shorts, and grounds.

Circuit specifications

Device loops	1 loop, expandable to 2, Class A or B, each loop supporting up to 250 device addresses
Communication line voltage	Maximum 20 V peak-to-peak
Circuit current	0.5 A max
Circuit impedance	66Ω total, 0.5 μF, max
Isolators	64 maximum

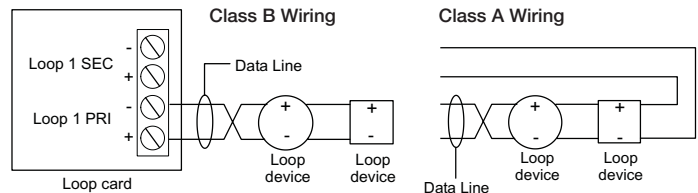

Annunciator loop (TB4)

The control panel provides a connection for up to eight serially driven and supervised remote annunciators.

Circuit specifications

Device loops	Class B (Style Y) or Class A (Style Z)
Circuit voltage	2.55 V
Circuit current	30 mA max
Circuit impedance	Up to 8 annunciators or 4000 feet

Class B

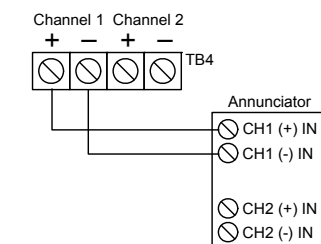

Class A

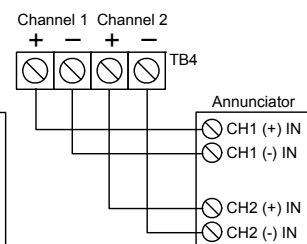

Alarm, trouble, and supervisory relay (TB3)

The trouble relay is normally-open, held closed, and opens on any trouble event or when the panel is de-energized. The supervisory relay is normally-open, and closes on any supervisory event. The alarm relay changes over on any alarm event.

Relay specifications

	Alarm	Trouble	Supervisory
Type	Form C		Form A
Voltage	24 VDC at 1 A resistive	24 VDC at 1 A resistive	

Relay circuits can only be connected to power-limited sources.

Option Cards

V-Series panels are supported by a complete line of modules and related equipment that enhance performance and extend system capabilities. Option cards are easy to install and set up. They simply plug directly into the control panel main circuit board or are connected to it with a ribbon cable. After installation, terminals remain easily accessible for quick connection of field wiring. The cabinet provides ample room for wire routing, keeping wiring neat and easy to service at all times.

SA-ETH Ethernet Interface Card

SA-ETH wiring

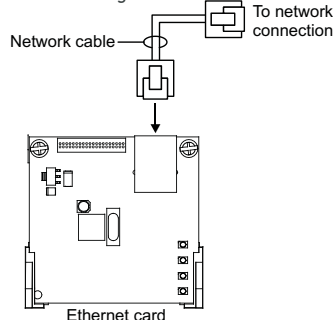

The SA-ETH card provides a standard 10/100 Base T Ethernet network connection for connecting to an intranet, a local network, or the Internet. The card can be used to download configuration programming from the VS-CU to the panel over the network.

The Ethernet card is installed on the plastic assembly and connects to the main circuit board via a ribbon cable.

SA-ETH specifications

Ethernet	10/100 Base T
Operating environment	
Temperature	32 to 120°F (0 to 49°C)
Humidity	0 to 93% RH, noncondensing at 90°F (32°C)

V-SLC Loop Expander Card

The V-SLC Loop Expander Card provides an additional device loop on the control panel. The card expands the control panel's device capacity to 500 total device addresses, 250 per loop. The card is compatible with Class B or Class A wiring. It is compatible with VS2 control panels only.

The loop expander card connects to connector J7 on the main circuit board.

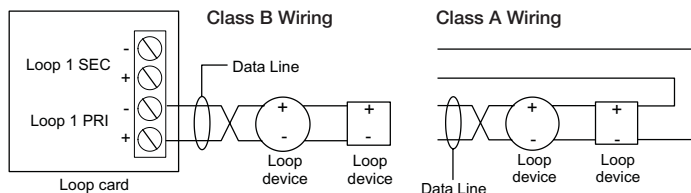

V-SLC specifications

Device addresses on loop	125 detectors and 125 modules
Wiring	Class B (Style Y) or Class A (Style Z)
Operating voltage	20 V peak-to-peak
Operating current	0.5 A total
Circuit impedance	66 Ω, 0.5 μF, max
Terminal rating	12 to 18 AWG (0.75 to 2.5 sq mm)
Operating environment	
Temperature	32 to 120°F (0 to 49°C)
Humidity	0 to 93% RH, noncondensing at 90°F (32°C)

SMK Smoke Power Converter

The SMK Smoke Power Converter Module provides a regulated power source for two-wire smoke circuits connected to a Signature data circuit. The SMK monitors the operating power from the power supply. When power begins to degrade, the SMK provides the necessary operating voltage to the two-wire smoke detection circuits.

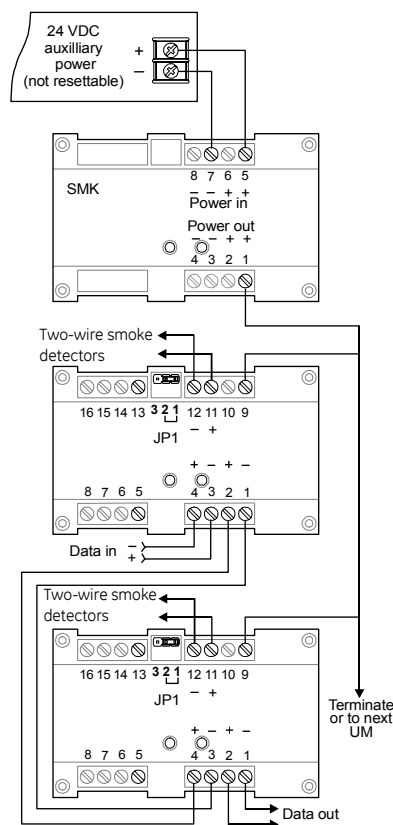

SMK specifications

Input voltage	21.9 to 28.3 VDC (not resettable)
Output voltage	24 VDC nom. at 200 mA, max., special applications
Ground fault impedance	10 k ohm
Operating environment	
Temperature	32 to 120°F (0 to 49°C)
Humidity	0 to 93% RH, noncondensing at 90°F (32°C)
Storage temperature	-4 to 140°F (-20 to 60°C)
Compatible electrical boxes	North American 4 inch square x 2-1/2 in. (64 mm) deep 2 gang box or Standard 4 in. square box 1-1/2 in. (38 mm) deep
Wire size	14, 16, or 18 AWG wire (1.5, 1.0, or 0.75 sq. mm) (Sizes 16 and 18 AWG are preferred)

SA-DACT Dialer

The SA-DACT provides communications between the control panel and the central station over a telephone line system. It transmits system status changes (events) to a compatible digital alarm communicator receiver over the public switched telephone network. The dialer is capable of single, dual, or split reporting of events to two different account and telephone numbers. The modem feature of the SA-DACT can also be used for uploading and downloading panel configuration, history, and current status to a PC running the VS-CU.

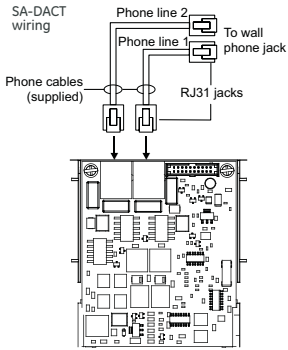

The dialer phone lines connect to connectors on the dialer's main circuit board. Phone line 1 connects to connector J4 and phone line 2 connects to connector J1.

The SA-DACT queues messages and transmits them based on priority (alarm, supervisory, trouble, and monitor). Activations are transmitted before restorations.

The SA-DACT is installed on the plastic assembly and connects to the main circuit board via a ribbon cable.

SA-DACT specifications

Phone line type	One or two loop-start lines on a public, switched network
Phone line connector	RJ-31/38X (C31/38X)
Communication formats	Contact ID (SIA DC-05)
Operating environment	
Temperature	32 to 120°F (0 to 49°C)
Humidity	0 to 93% RH, noncondensing at 90°F (32°C)

Compatible DACRs

Receiver	Models	Formats
Ademco	685	Contact ID
FBII	CP220	Contact ID
Osborne-Hoffman	OH 2000	Contact ID
Radionics	D6600	Contact ID
Silent Knight	9800	Contact ID
Sur-Gard	SG-MLR1, MLR2	Contact ID

SA-232 RS-232 interface

The SA-232 card provides an RS-232 interface with VS2 panels. It can be used for connecting a printer to the control panel to print system events. The card also can be used for connecting a computer to download a configuration program from the VS-CU to the control panel.

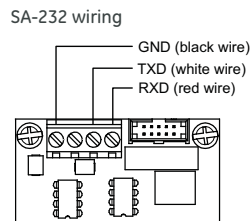

The RS-232 card is installed on the plastic assembly and connects to the main circuit board via a ribbon cable.

SA-232 specifications

Operating voltage	Standard EIA-232
Terminal rating	12 to 18 AWG (0.75 to 2.5 sq mm)
Operating environment	
Temperature	32 to 120°F (0 to 49°C)
Humidity	0 to 93% RH, noncondensing at 90°F (32°C)

GSA-REL Releasing Module

The GSA-REL is an analog addressable module that communicates directly with the fire alarm panel Signature loop controller. The GSA-REL controls sprinkler, pre-action and deluge systems, and may also be used to release extinguishing agents such as CO₂, Halon, or foam. The module is easily configured in the field and offers a wide range of options that ensure dependable service, while preventing the unnecessary release of extinguishing agent.

GSA-REL specifications

Power riser	Input voltage	24 Vdc (power limited)
	Supervisory current	25 mA, max.
	Riser input current	4 amps maximum
	Alarm	170 mA min.; 4 A max.
Release circuits	Output rating	2 A @ 24 Vdc (per circuit)
	Valves per circuit	4 valves, max.
	Max. supervisory current	0.4 mA (short circuit)
	Nominal supervisory current	0.18 mA
Pre-release alarm circuits	Supervisory voltage	26 Vdc, max. (open circuit)
	End of line device	47k Ohm EOL
	Output rating	2 A @ 24 Vdc (for each circuit)
	Max. supervisory current	0.4 mA (short circuit)
Manual release input circuit	Nominal supervisory current	0.18 mA
	Supervisory voltage	26 Vdc, max. (open circuit)
	End of line device	47k Ohm resistor
	Circuit type	Class B N.O. latching
Abort circuit	Circuit capacitance	0.1 μF, max
	Max. supervisory current	0.4 mA (short circuit)
	Nominal supervisory current	0.18 mA
	Supervisory voltage	26 Vdc, max. (open circuit)
First alarm output relay	End of line device	47k Ohm resistor
	Circuit type	Class B N.O. non-latching
	Circuit capacitance	0.1 μF, max
	Contact rating	3 A @ 24 Vdc (0.6 power factor) Form C
Signature Data line	Operating voltage	5.2 to 19.95 Vdc
	Supervisory current	1000 μA
	Alarm current	1000 μA

Note: Output circuits are power-limited when the riser circuit is power-limited.

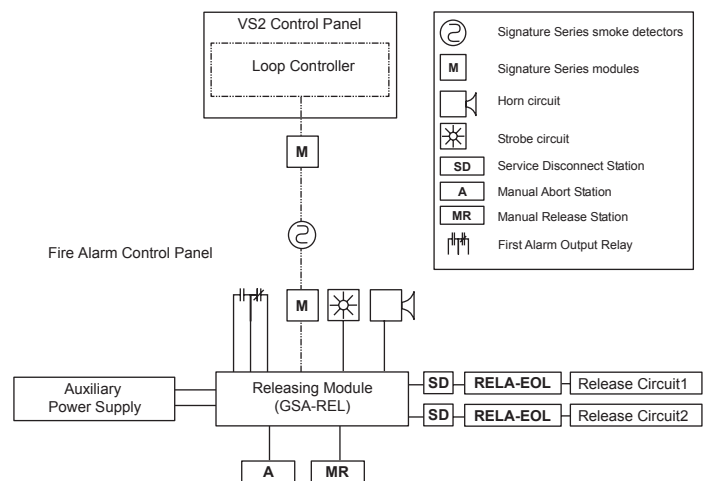

For detailed specification and ordering information on the GSA-REL, refer to Data Sheet M85001-0531 -- Releasing Module.

Specifications

Device loops	1 loop, expandable to 2, Class A or B, each loop supporting up to 250 device addresses
NAC circuits	4 Class B or 2 Class A, 2.5 amps each
Power supply	6.0 A total, 2.5 A max. per circuit at 120/230 VAC 60 Hz 5.0 A total at 230VAC 50 Hz, 2.5 A max. per circuit 0.5 amps aux power
NAC Operating voltage	24 VDC. NAC minimum voltage: 19.5 VDC @ 20.4 V battery voltage
SLC Loop circuit operating voltage	20 V peak-to-peak
Primary power	120 VAC, 60 Hz, 230 VAC 50-60 Hz
Aux Power 1 (Continuous circuit)	24 VDC nominal at 500 mA. A SMK module is required when using the GSA-UM module to support two-wire smoke detectors.
Aux Power 2 (Resettable circuit)	24 VDC nominal at 500 mA.
Auxiliary output	19 to 25.7 VDC
Base panel current draw	Standby: 172 mA Alarm: 267 mA
Panel History Log	1,000 events

Battery placement	VS2 cabinets accommodate up to 18 A/H batteries. Use a external cabinet for larger battery sizes.
Batteries	Batteries must be sealed lead acid type only. Maximum charging capacity = 26 Ah.
Loop circuit	Maximum loop resistance: 66 Ω. Maximum loop capacitance: 0.5 μF. Style 4, 6, and 7 wiring. 64 isolators maximum.
GSA-UM/GSA-MAB	1.5 mA (see the UL and ULC compatibility list for for the maximum quantity of detectors per circuit)
Compatibility ID	100
Alarm contact	Form C 24 VDC @ 1 A (resistive load)
Trouble contact	Form C 24 VDC @ 1 A (resistive load)
Supervisory contact	Form A 24 VDC @ 1 A (resistive load)
Environmental	Temperature: 0 to 49°C (32 to 120°F). Humidity: 0 to 93% RH, noncondensing.
Terminal rating	All terminals rated for 12 to 18 AWG (0.75 to 2.5 mm ²)
Serial communications	Voltage: 2.55 V. Current: 30 mA max
Remote annunciator	8 drops max, RS-485 Class A or B
Input zones	32 max.
Agency Listing	UL864, UL2017, CSFM, ULC and NYFD #6020, FM approved

Ordering Information

Part Description

VS2 Intelligent Multi-Loop Systems, 500 analog point capacity

VS2-R	1 Loop System, 4 NACs, Red door. Surface mount enclosure, 115 Vac, English.
VS2-RD	1 Loop System, two-line dialer, 4 NACs, Red door. Surface mount enclosure, 115 Vac, English.
VS2-G	1 Loop System, 4 NACs, Silver door. Surface mount enclosure, 115 Vac, English.
VS2-GD	1 Loop System, two-line dialer, 4 NACs, Silver door. Surface mount enclosure, 115 Vac, English.
VS2-GC ⁽¹⁾	1 Loop System, 4 NACs, 16 zone LED display, Silver door. Surface mount enclosure, 115 Vac, English.
VS2-G-F ⁽¹⁾	1 Loop System, 4 NACs, 16 zone LED display, Silver door. Surface mount enclosure, 115 Vac, French.
VS2-G-2 ⁽²⁾	1 Loop System, 4 NACs, Silver door. Surface mount enclosure, 230 Vac, English.
VS2-R-2 ⁽²⁾	1 Loop System, 4 NACs, Red door. Surface mount enclosure, 230 Vac, English.
VS2-G-SP ⁽²⁾	1 Loop System, 500 point capacity, 4 NACs, silver door. Surface mount enclosure, 115 Vac, Spanish
VS2-G-2-SP ⁽²⁾	1 Loop System, 500 point capacity, 4 NACs, silver door. Surface mount enclosure, 230 Vac, Spanish
VS2-G-PG ⁽²⁾	1 Loop System, 500 point capacity, 4 NACs, silver door. Surface mount enclosure, 115 Vac, Portuguese
VS2-G-2-PG ⁽²⁾	1 Loop System, 500 point capacity, 4 NACs, silver door. Surface mount enclosure, 230 Vac, Portuguese
SA-TRIM2	Flush mount trim, black

Replacement Electronics

500elec-VS	Replacement Base electronics, Vigilant, 500pt system, includes main board, base plate, User interface and 1 loop.
500elec-VS-FR ⁽¹⁾	Replacement Base electronics, Vigilant, 500pt system, includes main board, base plate, User interface and 1 loop, French
500elec-VS-SP ⁽²⁾	Replacement Base electronics, Vigilant, 500pt system, includes main board, base plate, User interface and 1 loop, Spanish
500elec-VS-PG ⁽²⁾	Replacement Base electronics, Vigilant, 500pt system, includes main board, base plate, User interface and 1 loop, Portuguese

Option Cards

SA-DACT	Dual Line Dialer/Modem, supports Contact ID, mounts in cabinet on base plate.
SA-232	Serial Port (RS-232), for connection to printers & computers, mounts in cabinet to base plate
SA-ETH	Ethernet Port, Slave, mounts in cabinet on base plate
V-SLC	SLC Loop Expansion Module. Adds second loop to VS2 systems, 250 point capacity. Mounts in cabinet on main board.
D16L-VS	LED Annunciator Module, 16 groups, 2 LEDs per group with insertable labeling. Mounts in cabinet on VS2 systems.

Remote Annunciators (refer to Data Sheet 85005-0128)**LCD Remote Annunciators (mount to standard 4" square electrical box)**

RLCD	Remote Annunciator, 4X20 LCD & Common Indicators for displaying system status. Off-white housing.
RLCD-R	Remote Annunciator, 4X20 LCD & Common Indicators for displaying system status. Red housing.
RLCD-C	Remote Annunciator, 4X20 LCD. Common controls and status indicators. Off-white housing.
RLCD-CR	Remote Annunciator, 4X20 LCD. Common controls and status indicators. Red housing.
RLCDF ⁽¹⁾	Remote Annunciator, 4X20 LCD & Common Indicators for displaying system status. Off-white housing.
RLCD-CF ⁽¹⁾	Remote Annunciator, 4X20 LCD. Common controls and status indicators. Off-white housing.
RLCD-SP ⁽²⁾	Remote Annunciator, 4X20 LCD. Common system status indicators. Off-white housing. Spanish.
RLCD-PG ⁽²⁾	Remote Annunciator, 4X20 LCD. Common system status indicators. Off-white housing. Portuguese.
RLCD-C-SP ⁽²⁾	Remote Annunciator, 4X20 LCD. Common controls and status indicators. Off-white housing. Spanish.
RLCD-C-PG ⁽²⁾	Remote Annunciator, 4X20 LCD. Common controls and status indicators. Off-white housing. Portuguese.

LED Remote Annunciators & Expander (mount to standard 4" square electrical box)

RLED-C	Remote Annunciator. Common controls and status indicators with 16 X 2-LED groups for zone display. Off-white housing.
RLED-CR	Remote Annunciator. Common controls and status indicators with 16 X 2-LED groups for zone display. Red housing.
RLED-CF ⁽¹⁾	Remote Annunciator. Common controls and status indicators with 16 X 2-LED groups for zone display. Off-white housing, French.
RLED-C-SP ⁽²⁾	Remote Annunciator, common controls and status indicators. 16 groups w/2 LEDs each for zone display. Off-white housing. Spanish.
RLED-C-PG ⁽²⁾	Remote Annunciator, common controls and status indicators. 16 groups w/2 LEDs each for zone display. Off-white housing. Portuguese.
RLED24	Remote Annunciator Zone expander. 24 X 2-LED groups with custom label areas for display of alarm and trouble. Off-white housing.
RLED24R	Remote Annunciator Zone expander. 24 X 2-LED groups with custom label areas for display of alarm and trouble. Red housing.

Remote Annunciator Cabinets & Accessories

RA-ENC1	Remote Annunciator Enclosure, key locked with plexiglass window for one RLCD(C) or RLED(C).
RA-ENC2	Remote Annunciator Enclosure, key locked with plexiglass window with space for 2 of either RLCDx, RLEDx or RLED24.
RA-ENC3	Remote Annunciator Enclosure, key locked with plexiglass window with space for 3 of either RLCDx, RLEDx or RLED25.
RKEY	Keypad, single gang, provides key operated enable or disable of common controls on RLCD or RLED units.
LSRA-SB	Surface Mount Box - for R Series single units.

Graphic Annunciator Drivers (comes with a snap track for mounting in custom graphic enclosures)

GCI	Provides outputs for common indicators and 32 alarm/supv zones as well as inputs for common switches.
-----	---

Programming Tools

VS-CU	Vigilant VS Series configuration and diagnostics utility.
260097	RS232 cable, 4 conductor, DB9 PC interface

Notes: ⁽¹⁾ Available in Canada only. ⁽²⁾ Available in international markets only.**Analog Addressable Detectors and Bases**

		Shipping Wt.
V-PHS	Intelligent Analog Optical/Fixed Temperature Detector	0.25 (0.11)
V-PS	Intelligent Analog Optical Smoke Detector	0.25 (0.11)
V-HRD	Intelligent Analog Rate-of-Rise Heat Detector	0.25 (0.11)
V-HFD	Intelligent Analog Fixed Temperature Heat Detector	0.25 (0.11)
V-PCOS	Intelligent Photoelectric Detector with carbon monoxide sensor	0.4 (0.16)
GSA-SBT	Audible (Sounder) Base for CO and Fire Detectors	0.3 (0.15)
GSA-SD	Intelligent Analog Duct Detector	2.4 (1.1)
B4U	Standard Base	0.11 (0.05)
RB4U	Relay Detector Base	0.11 (0.05)
IB4U	Isolator Detector Base	0.11 (0.05)
SB4U	Audible (Sounder) Detector Base	0.11 (0.05)
AB4G-SB	Surface Box for Audible Base	1.0 (0.45)
RLED	Remote alarm LED, use with standard base only	0.2 (.09)

System Accessories

		Shipping Wt.
CTM	City Tie Module. Mounts in 2-gang electric box. Provides connection to a local energy fire alarm box.	0.6 (0.3)
BC-1	Battery Cabinet. 14.0" x 18.25" x 7.25" Free-standing cabinet with key lock. Supports up to 40 Ah batteries. Holds up to 2 12V24A batteries.	50.0 (22.7)
BC-1R	Battery Cabinet - Red. 14.0" x 18.25" x 7.25" Free standing cabinet with key lock. Supports up to 40 Ah batteries. Holds up to 2 12V24A batteries.	50.0 (22.7)
BC-1EQ	Seismic hardening Kit for VS series panels. Includes battery hardening for BC-1 enclosure and components to harden panel internal components. See note.	
IOP3A	Isolator Module - RS232. For use with short haul modems.	1.61 (0.7)
RPM	Reverse Polarity Module	3.0 (1.36)
MFC-A	Multifunction Fire Cabinet, 8" x 14" x 3.5" - RED.	20.6 (9.4)
MIR-PRT/S	System Printer - Desktop style.	36.6 (16.6)

Analog Addressable Modules		Shipping Wt.
GSA-CC1	Single Input Signal Module (Standard Mount)	0.5 (0.23)
GSA-MCC1	Single Input Signal Module (UIO Mount)	0.18 (0.08)
GSA-CC1S	Synchronization Output Module (Standard Mount)	0.5 (0.23)
GSA-MCC1S	Synchronization Output Module (UIO Mount)	0.18 (0.08)
GSA-T3T4	Temporal Pattern Generator	0.2 (0.1)
GSA-CC2	Dual Input Signal Module (Standard Mount)	0.5 (0.23)
GSA-MCC2	Dual Input Signal Module (UIO Mount)	0.18 (0.08)
GSA-CR	Control Relay Module (Standard Mount)	0.4 (0.15)
GSA-MCR	Control Relay Module (UIO Mount)	0.18 (0.08)
GSA-CRR	Polarity Reversal Relay Module (Standard Mount)	0.4 (0.15)
GSA-MCRR	Polarity Reversal Relay Module (UIO Mount)	0.18 (0.08)
GSA-RM1	Riser Monitor Module (Standard Mount)	0.5 (0.23)
GSA-MRM1	Riser Monitor Module (Plug-in)	0.18 (0.08)
GSA-IO	Input/Output Module (Standard Mount)	0.34 (0.15)
GSA-MIO	Input/Output Module (Plug-in)	0.22 (0.10)
GSA-CT1	Single Input Module	0.4 (0.15)
GSA-CT2	Dual Input Module	0.4 (0.15)
GSA-MCT2	Dual Input Plug-in (UIO) Module	0.1 (0.05)
GSA-IM	Fault Isolator Module	0.5 (0.23)
GSA-MM1	Monitor Module	0.4 (0.15)
GSA-REL	Analog addressable releasing module	0.5 (0.23)
276A-REL	Manual releasing station (single-action). English markings, black text on yellow polycarbonate body.	1.0 (0.45)
278A-REL	Manual releasing station (double-action). English markings, black text on yellow polycarbonate body.	1.0 (0.45)
RELA-ABT	Manual Abort Station. English markings, black text on yellow polycarbonate body.	1.0 (0.45)
RELA-SRV-1	Service Disconnect Switch. One n/c contact and one n/o contact. English markings, white text on blue polycarbonate body.	1.0 (0.45)
RELA-EOL	Polarized end-of-line relay. English markings on stainless steel cover.	0.2 (0.1)
GSA-WTM	Waterflow/Tamper Module	0.4 (0.15)
SMK	Smoke Power Converter Module	0.4 (0.15)

Note:

For earthquake anchorage, including detailed mounting weights and center of gravity detail, please refer to Seismic Application Guide 3101987-EN. Approval of panel anchorage to site structure may require local AHJ, structural, or civil engineer review.

Standby batteries must be mounted externally from fire panel in separately mounted BC-1 enclosure. Order BC-1 and BC-1EQ separately.



Contact us...

Email: edwards.fire@fs.utc.com

Web: www.vigilant-fire.com

Vigilant is an **EDWARDS** brand.

1016 Corporate Park Drive
Mebane, NC 27302

© 2013 UTC Fire & Security Americas Corporation, Inc. All rights reserved.
Specifications subject to change without notice. Edwards is part of UTC Climate, Controls & Security, a unit of United Technologies Corporation.
