



**Liquid Crystal Display  
LCD-80  
Installation Manual**

Document 15037 9/9/02	Rev: <b>D2</b>
PN 15037:D2	ECN 02-339

# Fire Alarm System Limitations

*While a fire alarm system may lower insurance rates, it is not a substitute for fire insurance!*

**An automatic fire alarm system**—typically made up of smoke detectors, heat detectors, manual pull stations, audible warning devices, and a fire alarm control with remote notification capability—can provide early warning of a developing fire. Such a system, however, does not assure protection against property damage or loss of life resulting from a fire.

The Manufacturer recommends that smoke and/or heat detectors be located throughout a protected premise following the recommendations of the current edition of the National Fire Protection Association Standard 72 (NFPA 72), manufacturer's recommendations, State and local codes, and the recommendations contained in the Guide for Proper Use of System Smoke Detectors, which is made available at no charge to all installing dealers. A study by the Federal Emergency Management Agency (an agency of the United States government) indicated that smoke detectors may not go off in as many as 35% of all fires. While fire alarm systems are designed to provide early warning against fire, they do not guarantee warning or protection against fire. A fire alarm system may not provide timely or adequate warning, or simply may not function, for a variety of reasons:

**Smoke detectors** may not sense fire where smoke cannot reach the detectors such as in chimneys, in or behind walls, on roofs, or on the other side of closed doors. Smoke detectors also may not sense a fire on another level or floor of a building. A second-floor detector, for example, may not sense a first-floor or basement fire.

**Particles of combustion or "smoke"** from a developing fire may not reach the sensing chambers of smoke detectors because:

- Barriers such as closed or partially closed doors, walls, or chimneys may inhibit particle or smoke flow.
- Smoke particles may become "cold," stratify, and not reach the ceiling or upper walls where detectors are located.
- Smoke particles may be blown away from detectors by air outlets.
- Smoke particles may be drawn into air returns before reaching the detector.

The amount of "smoke" present may be insufficient to alarm smoke detectors. Smoke detectors are designed to alarm at various levels of smoke density. If such density levels are not created by a developing fire at the location of detectors, the detectors will not go into alarm. Smoke detectors, even when working properly, have sensing limitations. Detectors that have photoelectronic sensing chambers tend to detect smoldering fires better than flaming fires, which have little visible smoke. Detectors that have ionizing-type sensing chambers tend to detect fast-flaming fires better than smoldering fires. Because fires develop in different ways and are often unpredictable in their growth, neither type of detector is necessarily best and a given type of detector may not provide adequate warning of a fire.

Smoke detectors cannot be expected to provide adequate warning of fires caused by arson, children playing with matches (especially in bedrooms), smoking in bed, and violent explosions (caused by escaping gas, improper storage of flammable materials, etc.).

**Heat detectors** do not sense particles of combustion and alarm only when heat on their sensors increases at a predetermined rate or reaches a predetermined level. Rate-of-rise heat detectors may be subject to reduced sensitivity over time. For this reason, the rate-of-rise feature of each detector should be tested at least once per year by a qualified fire protection specialist. Heat detectors are designed to protect property, not life.

**IMPORTANT! Smoke detectors** must be installed in the same room as the control panel and in rooms used by the system for the connection of alarm transmission wiring, communications, signaling, and/or power. If detectors are not so located, a developing fire may damage the alarm system, crippling its ability to report a fire.

**Audible warning devices** such as bells may not alert people if these devices are located on the other side of closed or partly open doors or are located on another floor of a building. Any warning device may fail to alert people with a disability or those who have recently consumed drugs, alcohol or medication. Please note that:

- Strobes can, under certain circumstances, cause seizures in people with conditions such as epilepsy.
- Studies have shown that certain people, even when they hear a fire alarm signal, do not respond or comprehend the meaning of the signal. It is the property owner's responsibility to conduct fire drills and other training exercise to make people aware of fire alarm signals and instruct them on the proper reaction to alarm signals.
- In rare instances, the sounding of a warning device can cause temporary or permanent hearing loss.

**A fire alarm system** will not operate without any electrical power. If AC power fails, the system will operate from standby batteries only for a specified time and only if the batteries have been properly maintained and replaced regularly.

**Equipment used in the system** may not be technically compatible with the control. It is essential to use only equipment listed for service with your control panel.

**Telephone lines** needed to transmit alarm signals from a premise to a central monitoring station may be out of service or temporarily disabled. For added protection against telephone line failure, backup radio transmission systems are recommended.

**The most common cause** of fire alarm malfunction is inadequate maintenance. To keep the entire fire alarm system in excellent working order, ongoing maintenance is required per the manufacturer's recommendations, and UL and NFPA standards. At a minimum, the requirements of Chapter 7 of NFPA 72 shall be followed. Environments with large amounts of dust, dirt or high air velocity require more frequent maintenance. A maintenance agreement should be arranged through the local manufacturer's representative. Maintenance should be scheduled monthly or as required by National and/or local fire codes and should be performed by authorized professional fire alarm installers only. Adequate written records of all inspections should be kept.

Precau-S-4-2002.fm

## Installation Precautions

*Adherence to the following will aid in problem-free installation with long-term reliability:*

**WARNING - Several different sources of power can be connected to the fire alarm control panel.** Disconnect all sources of power before servicing. Control unit and associated equipment may be damaged by removing and/or inserting cards, modules, or interconnecting cables while the unit is energized. Do not attempt to install, service, or operate this unit until this manual is read and understood.

**CAUTION - System Reaccepting Test after Software Changes.** To ensure proper system operation, this product must be tested in accordance with NFPA 72 Chapter 7 after any programming operation or change in site-specific software. Reaccepting testing is required after any change, addition or deletion of system components, or after any modification, repair or adjustment to system hardware or wiring.

All components, circuits, system operations, or software functions known to be affected by a change must be 100% tested. In addition, to ensure that other operations are not inadvertently affected, at least 10% of initiating devices that are not directly affected by the change, up to a maximum of 50 devices, must also be tested and proper system operation verified.

This system meets NFPA requirements for operation at 0-49° C/32-120° F and at a relative humidity of 85% RH - 93% per ULC - (non-condensing) at 30° C/86° F. However, the useful life of the system's standby batteries and the electronic components may be adversely affected by extreme temperature ranges and humidity. Therefore, it is recommended that this system and all peripherals be installed in an environment with a nominal room temperature of 15-27° C/60-80° F.

**Verify that wire sizes are adequate** for all initiating and indicating device loops. Most devices cannot tolerate more than a 10% I.R. drop from the specified device voltage.

**Like all solid state electronic devices,** this system may operate erratically or can be damaged when subjected to lightning-induced transients. Although no system is completely immune from lightning transients and interferences, proper grounding will reduce susceptibility. Overhead or outside aerial wiring is not recommended, due to an increased susceptibility to nearby lightning strikes. Consult with the Technical Services Department if any problems are anticipated or encountered.

**Disconnect AC power and batteries** prior to removing or inserting circuit boards. Failure to do so can damage circuits.

**Remove all electronic assemblies** prior to any drilling, filing, reaming, or punching of the enclosure. When possible, make all cable entries from the sides or rear. Before making modifications, verify that they will not interfere with battery, transformer, and printed circuit board location.

**Do not tighten screw terminals** more than 9 in-lbs. Overtightening may damage threads, resulting in reduced terminal contact pressure and difficulty with screw terminal removal.

**Though designed to last many years,** system components can fail at any time. This system contains static-sensitive components. Always ground yourself with a proper wrist strap before handling any circuits so that static charges are removed from the body. Use static-suppressive packaging to protect electronic assemblies removed from the unit.

**Follow the instructions** in the installation, operating, and programming manuals. These instructions must be followed to avoid damage to the control panel and associated equipment. FACP operation and reliability depend upon proper installation by authorized personnel.

Precau-S-4-2002.fm

### FCC Warning

**WARNING:** This equipment generates, uses, and can radiate radio frequency energy and if not installed and used in accordance with the instruction manual, may cause interference to radio communications. It has been tested and found to comply with the limits for class A computing device pursuant to Subpart B of Part 15 of FCC Rules, which is designed to provide reasonable protection against such interference when operated in a commercial environment. Operation of this equipment in a residential area is likely to cause interference, in which case the user will be required to correct the interference at his own expense.

#### Canadian Requirements

This digital apparatus does not exceed the Class A limits for radiation noise emissions from digital apparatus set out in the Radio Interference Regulations of the Canadian Department of Communications. Le présent appareil numérique n'émet pas de bruits radioélectriques dépassant les limites applicables aux appareils numériques de la classe A prescrites dans le Règlement sur le brouillage radioélectrique édicté par le ministère des Communications du Canada.

Acclimate Plus™, HARSH™, NOTI•FIRE•NET™, ONYX™, and VeriFire™ are trademarks, and FlashScan® and VIEW® are registered trademarks of NOTIFIER. NION™ and UniNet™ are trademarks of NIS. NIS™ and Notifier Integrated Systems™ are trademarks and NOTIFIER® is a registered trademark of Fire•Lite Alarms, Inc. Echelon® is a registered trademark and LonWorks™ is a trademark of Echelon Corporation. ARCNET® is a registered trademark of Datapoint Corporation. Microsoft® and Windows® are registered trademarks of the Microsoft Corporation. LEXAN® is a registered trademark of GE Plastics, a subsidiary of General Electric Company.

# Notes

# Table of Contents

<b>Section 1 Product Overview: LCD-80 Liquid Crystal Display .....</b>	<b>7</b>
1.1 Common Features .....	7
1.2 ACS Mode .....	7
1.3 TERMINAL Mode .....	8
<b>Section 2 The LCD-80 and ACS Mode .....</b>	<b>11</b>
2.1 Setting the LCD-80 Address for ACS Mode .....	13
2.2 Remote Printer Connections (ACS Mode) .....	16
2.3 Printer Configuration .....	18
2.4 Power Connections .....	19
2.5 Operating the LCD-80 in ACS Mode .....	21
2.6 Display Patterns .....	23
2.6.1 Normal Message .....	23
2.6.2 Alarm Message .....	24
2.6.3 20-Character Alarm Messages .....	24
2.6.4 Trouble Messages .....	25
2.6.5 Communications Failure Reporting .....	26
2.6.6 Remote Printer Operation .....	26
2.6.7 Display Illumination .....	27
2.7 Interface Operation .....	27
2.7.1 EIA-485 Interface .....	27
2.7.2 EIA-232 Interface .....	28
2.7.3 Programming the LCD-80 (ACS Mode) .....	28
2.7.4 Programming from the CRT Display Monitor .....	29
2.7.5 Configuring the CRT for Programming the LCD-80 .....	30
2.7.6 Programing from an IBM-Compatible Computer .....	31
2.8 Default Messages and Point Labels .....	32
2.9 Entering Custom Messages .....	33
2.10 Entering Custom Point Labels .....	35
<b>Section 3 The LCD-80 &amp; Terminal Mode .....</b>	<b>37</b>
3.1 Operating the LCD-80 in Terminal Mode .....	40
3.1.1 Display Patterns .....	40
3.1.2 Switch Functions in Terminal Mode .....	40
3.1.3 Terminal Mode EIA-485 Connection Requirements .....	41
<b>Appendix A EIA-485 Shield Terminations .....</b>	<b>45</b>
<b>Appendix B AIM-200 Point Annunciation .....</b>	<b>47</b>

# Notes

# Section 1 Product Overview:

## LCD-80 Liquid Crystal Display

The LCD-80 alphanumeric display module is an ancillary device used by Notifier fire alarm control panels including AFP-200, AFP-300, AFP-400, AFC-600, AM2020/AFP1010, NCA, NFS-640, System 5000, System 500, and System 2500 systems. The product has two basic modes of operation: ACS, where it acts as an alphanumeric annunciator, and Terminal, where it acts as a Display Interface.

### 1.1 Common Features

- 80-character LCD display backlights under normal & alarm conditions.
- Control switches for Acknowledge, Signal Silence and System Reset.
- Time/date display field.
- ABF-1/B package with key switch option.
- Mounts up to 6000 feet from the panel.
- Local piezo sounder with alarm/trouble resound.

### 1.2 ACS Mode

When operated in “ACS” mode, the LCD-80 provides a remote or local digital display and a printer interface for AFP-200, AFP-300, AFP-400, AFC-600, NFS-640, NCA, System 5000, System 500, and the AM2020/AFP1010.

- General status banner.
- 40-character custom label.
- Alarm/trouble count.
- Custom “normal” message.
- European option: first alarm/last alarm/alarm count.
- Field-programmable words (foreign language versions).
- STEP DISPLAY and TIME/DATE SET switches.
- Employs ACS interface - up to 32 per system.
- Printer output port - EIA-232, compatible with PRN printers.
- Field programmable, nonvolatile memory in two options:  
128 points, 40 character labels or 256 points, 20 character labels.

- Internal nonvolatile clock.
- AM2020/AFP1010 “vectored” printer capability.
- System 5000/System 500 panel mount option.

*System 5000/System 500 Note:* The LCD-80 does not display the “ON” status of output circuits and relays.

*AM2020/AFP1010 Note:* Security points must have “Security” as part of its custom label on the LCD-80 to differentiate between a fire alarm and a security alarm condition.

**Note:** The LCD-80 should not be used as a primary display in Canada.

### 1.3 TERMINAL Mode

In Terminal Mode, the LCD-80 is a simplified version of the display for AFP-200, AFP-300, AFP-400, AFC-600, AM2020/AFP-1010, NCA, and NFS-640 (but does not support a remote printer). Up to 32 of these terminals can provide annunciation and control from remote locations.

- Device type identifiers from control panel.
- Device & zone custom alpha labels from control panel.
- Time/date and Device address from control panel.
- Operates in addition to control panel CRT if desired.
- EIA-485 connects to control panel terminal port (requires CCM-1 only with DIA-1).
- No programming necessary — uses time and labels from the control panel.

**Note:** LCD-80 terminal mode is not supported by System 500 or System 5000.



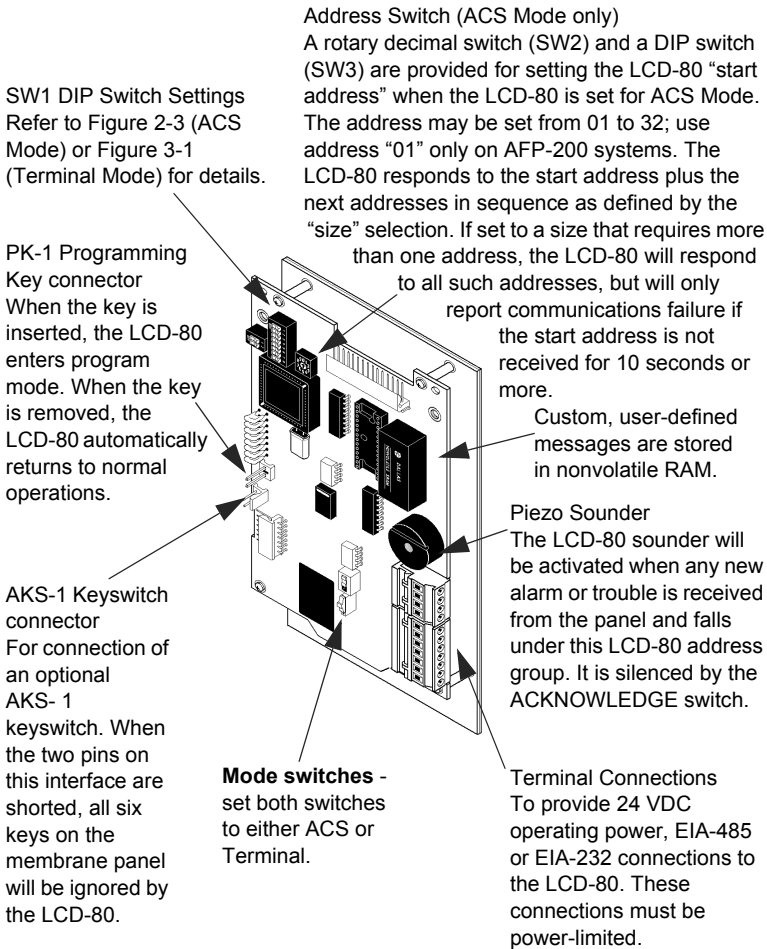

<p>Current Consumption @ 24 VDC          Normal (no activity): 100 mA          Standby (trouble condition): 50 mA          Alarm: 100 mA</p>
--

**Figure 1-1 LCD-80 Component Summary**

# Notes

## Section 2 The LCD-80 and ACS Mode

*System 5000/System 500:* Use of the LCD-80 with Remote Command Inputs is not recommended.

*AM2020/AFP1010:* Security points must have “security” as part of its custom label on the LCD-80 to differentiate between a fire alarm and a security alarm condition.

The primary application for the LCD-80 in ACS Mode is to add digital display and printer options to the System 5000, System 500 and AFP-200. It also provides an Alarm and Trouble Count option.

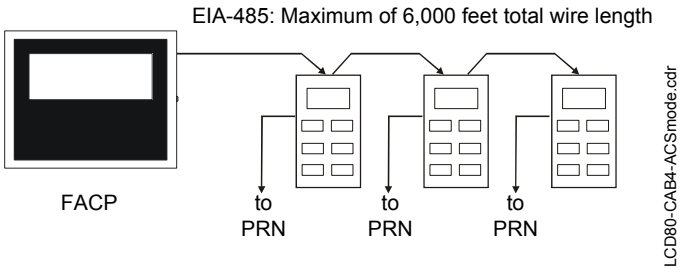

The power-limited EIA-485 interface provided by the control panels will support the installation of up to 32 devices. This figure includes the LCD-80, as well as AMG-1, ACS and LDM-series modules. On the System 5000, all but two devices must be “Receive Only.” On the System 500 and AFP-200, all but one device must be set for “Receive Only” operation.

The LCD-80 can be mounted in ABF-1/1B, ABS-1T/1TB, or ABS-1D backbox (not the ABS-1) or can mount on one slot of the CHS-4 chassis. The ABF-1/1B may include an AKS-1 keyswitch and APJ-1 phone jack. In addition, the LCD-80 contains an EIA-232 remote printer interface. This interface allows for connection of the UL Fire Alarm System-listed PRN printer.

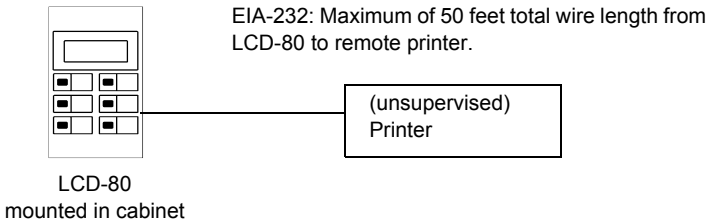

### 8-position DIP switch (SW1)

SW1-1) Set "ON" for Receive Only operation (for LCD-80s in addition to those that occupy available addresses).

SW1-2) Set "ON" for European Time.

SW1-3) Set "ON" to Piezo Disable.

SW1-4) Set "ON" to disable Acknowledge, Signal Silence and Reset switches.

SW1-5) Size (see Table 2-1 below).

SW1-6) Size (see Table 2-1 below).

SW1-7) Set "OFF" in this mode.

SW1-8) Not used.

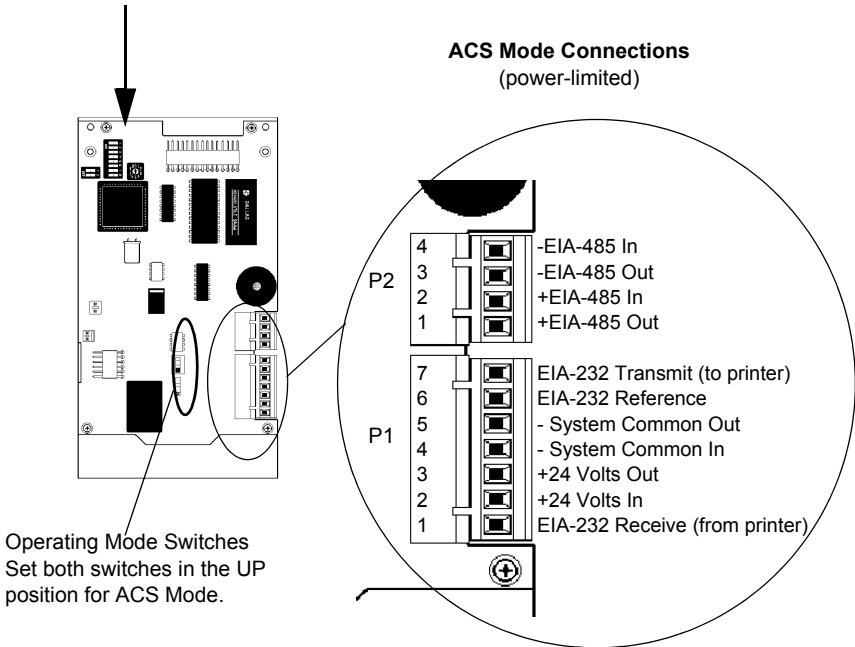

**Figure 2-1 Configuring the LCD-80 for ACS Mode**

DIP Switch		EIA-485 addresses	Number of points	Size of display labels	Max LCD-80s per system*	Max LCD-80s per AFP-200
5	6					
OFF	OFF	one	64	40 characters	32	2
OFF	ON	two	128	40 characters	16	1
ON	OFF	two	128	20 characters	16	1
ON	ON	four	255	20 characters	8	

\* Max LCD-80s per system doesn't restrict the number of LCD-80s that can be set for "Receive Only" (subject to system power supply limitations). A maximum of four LCD-80s can be powered by the AFP-200. Other equipment (ACS, LDM, etc.) that assumes addresses on the EIA-485 circuit will reduce the maximum number of LCD-80s that can be used in the system.

**Table 2-1 LCD-80 Size Select Table**

## 2.1 Setting the LCD-80 Address for ACS Mode

**Address select switch (SW2) (ACS Mode only).** SW2 sets the Least Significant Digit of the LCD-80's start address. The LCD-80 can consume up to four addresses on the EIA-485 circuit. If the LCD-80 uses more than one address (see Table 2-2), this switch selects the first address and the other addresses follow in numerical order.

**Address DIP Switch (SW3).**

In ACS Mode, this switch sets the Most Significant Digit of the LCD-80's start address (see Table 2-2). Set "Off" for use on AFP-200 systems.

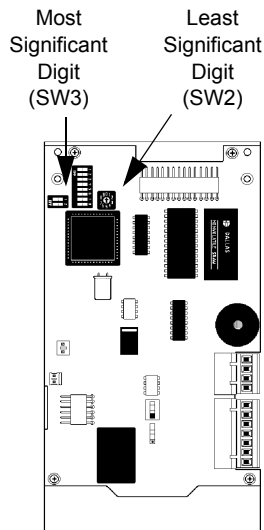

**Figure 2-2 DIP Switch Locations**

DIP SW3-1	DIP SW3-2	Rotary SW2	Start Address
OFF	OFF	0	n/a
OFF	OFF	01-09	01-09
ON	OFF	0-09	19-19
OFF	ON	0-09	20-29
ON	ON	0-02	30-32
ON	ON	03-09	n/a

**Table 2-2 Setting the LCD-80 Address in ACS Mode**

Alternately, the address could be determined by:

Example: Set the LCD-80 for a size of two addresses with start addresses of "01."

Set SW1-5 "OFF" Set SW1-6 "ON"	(sets a size of two)
Set SW3-1 "OFF" Set SW3-2 "OFF"	(assigns zero to most significant digit of start address)
Set SW2 to "1"	(sets the start address to "01")

The LCD-80 will now use addresses 01 and 02.

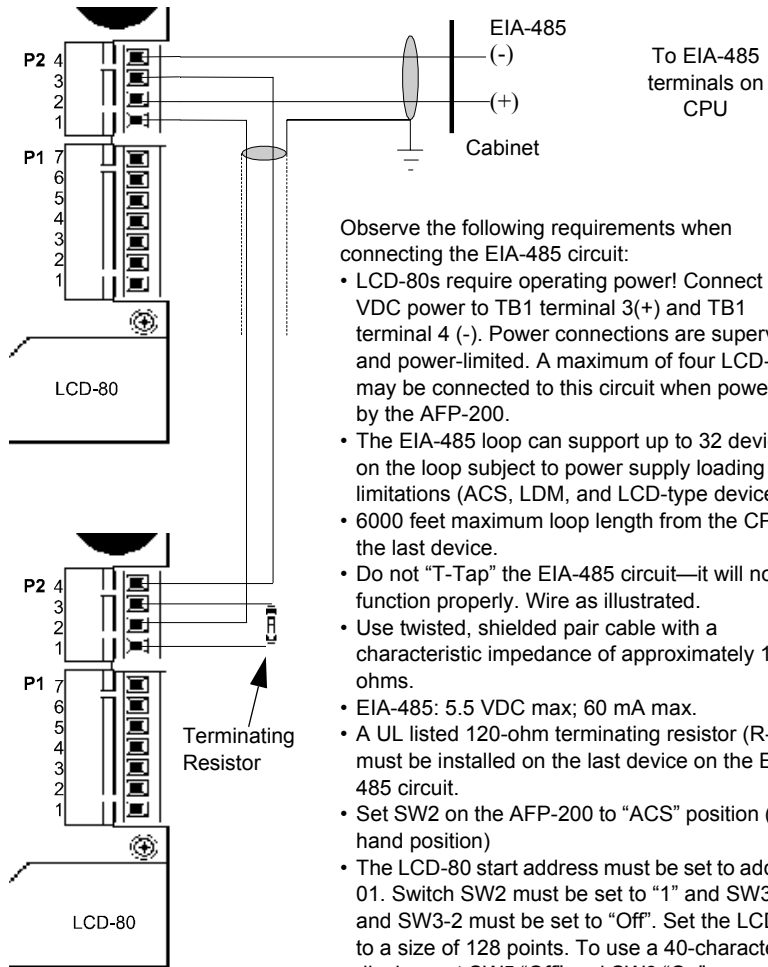

Observe the following requirements when connecting the EIA-485 circuit:

- LCD-80s require operating power! Connect 25 VDC power to TB1 terminal 3(+) and TB1 terminal 4 (-). Power connections are supervised and power-limited. A maximum of four LCD-80s may be connected to this circuit when powered by the AFP-200.
- The EIA-485 loop can support up to 32 devices on the loop subject to power supply loading limitations (ACS, LDM, and LCD-type devices)
- 6000 feet maximum loop length from the CPU to the last device.
- Do not “T-Tap” the EIA-485 circuit—it will not function properly. Wire as illustrated.
- Use twisted, shielded pair cable with a characteristic impedance of approximately 120 ohms.
- EIA-485: 5.5 VDC max; 60 mA max.
- A UL listed 120-ohm terminating resistor (R-120) must be installed on the last device on the EIA-485 circuit.
- Set SW2 on the AFP-200 to “ACS” position (right-hand position)
- The LCD-80 start address must be set to address 01. Switch SW2 must be set to “1” and SW3-1 and SW3-2 must be set to “Off”. Set the LCD-80 to a size of 128 points. To use a 40-character display, set SW5 “Off” and SW6 “On”.
- Refer to Appendix A for shield termination instructions.
- Terminal block connections on the Fire Alarm Control Panel are listed in Table 2-3; for illustrations, refer to your FACP manual.
- A separate reference wire is required for AM2020AFP1010 applications using ACS annunciators which are not in the same backbox as the fire alarm control panel’s CPU. Refer to the AM2020/AFP1010 manual for details.

**Figure 2-3 Connecting the EIA-485 Loop (ACS Mode)**

<b>AFP-200</b>	TB5-1 TB5-2	EIA-485 (+) EIA-485 (-)
<b>AFP-300, AFP-400, AFC-600</b>	TB4 (+) left pin TB4 (-) right pin	EIA-485 (+) EIA-485 (-)
<b>NCA</b>	TB3 (+) top pin TB3 (-) bottom pin	EIA-485 (+) EIA-485 (-)
<b>NFS-640</b>	TB-13 (+) TB-13 (-)	EIA-485 (+) EIA-485 (-)
<b>System 500, System 5000, System 2500</b>	TB2-1 TB2-2	EIA-485 (-) EIA-485(+)
<b>AM2020/AFP1010 (SIB2048, SIB2048A, SIBNET)</b>	P5-1 P5-2 P5-3 P5-4 P5-5 P5-6	EIA-485 Common Earth Ground Chassis EIA-485 Loop 1(+) EIA-485 Loop 1(-) EIA-485 Loop 2(+) EIA-485 Loop 2(-)

**Table 2-3 EIA-485 Control Panel Connections (ACS Mode)**  
Refer to your control panel manual for illustrations of panel-side terminals.

## 2.2 Remote Printer Connections (ACS Mode)

The LCD-80 supports the PRN Remote Printer. This printer provides a hard-copy printout of status changes within the system and time-stamps the printout with the current time-of-day and date. The PRN provides 80 columns of data on standard 9" by 11" tractor-feed paper.

Observe the following requirements when connecting a remote printer:

- Power-limited but not supervised.
- 50 feet maximum wire length (typical) from the LCD-80 to printer. Wiring distance limited by cable capacitance (see EIA-232 standard).
- Only one printer supported per LCD-80.
- Use twisted shielded pair cable suitable for EIA-232 applications.
- This interface is intended for use with UL listed printers, such as the PRN, that do not connect the EIA-232 Reference line to chassis ground. This is required to avoid creating an earth-fault condition.
- All EIA-232 circuit wiring to remain in same room as the LCD-80.



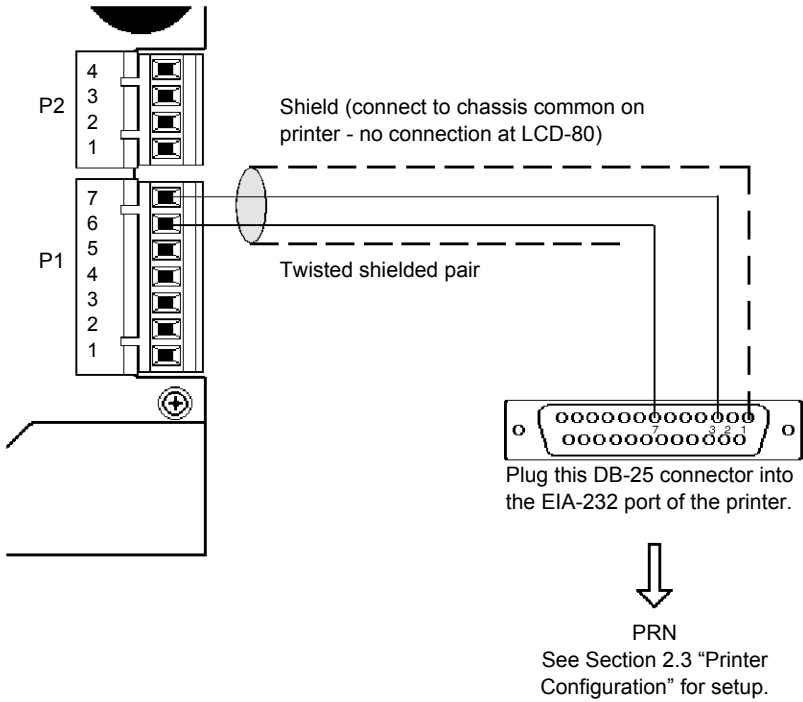

**Figure 2-4 Remote Printer Connection Diagram (ACS Mode)**

## 2.3 Printer Configuration

Refer to the documentation supplied with the PRN for instructions on the printer's menu controls. Set the printer's options as follows:

L/R ADJUST:	0
FONT:	HS DRAFT
LPI:	6 CPI
ESC CHARACTER:	ESC
BIDIRECTIONAL COPY:	ON
<hr/>	
CG-TAB:	GRAPHIC
COUNTRY:	E-USA ASCII
AUTO CR:	OFF
LANGUAGE:	ENGLISH
AUTO TEAR:	1S
<hr/>	
COLOR OPTION:	NOT INSTALLED
FORMLEN:	
LINES:	6 LPI=60
STANDARD:	EXECUTIVE 10.5"
<hr/>	
CPI:	10 CPI
SKIP:	0.5"
EMULATE:	EPSON
I/O:	
BUFFER:	36K
SERIAL:	
BAUD:	600
FORMAT:	8 BIT, NONE, 1 STOP
PROTOCOL:	XON/XOFF
CHARACTER SET:	STANDARD
S1.ZERO	ON
AUTO LF:	OFF
MENLOCK:	ALL
PAPER:	
BIN 1:	12/72"
BIN 2:	12/72"
SINGLE:	12/72"
PUSH TRA:	12/72"
PULL TRA:	12/72"
PAP ROLL:	12/72"
PAPOPT:	NO

## 2.4 Power Connections

The LCD-80 can be powered by MPS-24A, MPS-24B, AFP-200, NCA, FCPS-24, APS-6R, or other +24 VDC power supply UL-listed for fire protective applications, as well as FACPs with integral power supplies such as NFS-640.



**CAUTION: Do not power the LCD-80 from any unfiltered power source designed for powering NAC devices. This may damage the equipment.**

The power run to the LCD-80 must be power-limited but need not contain a Power Supervision Relay since loss of power is inherently supervised through communication loss. Maximum LCD-80 current draw from power supply is 100 mA. Maximum current draw from the control panel's secondary power source (batteries) under loss of AC power is 50 mA (when the LCD-80 is operating ACS mode on the AM2020/AFP1010, the current draw remains at 100mA under loss of AC power). Include these currents in your power supply loading and battery calculations.

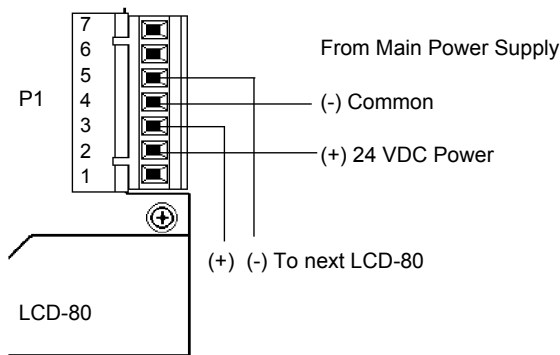

	24 VDC (+)	Common (-)
<b>MPS-24A</b>	TB3-3	TB3-4
<b>MPS-24B</b>	TB2-1	TB2-2
<b>AFP-200</b>	TB1-3	TB1-4
<b>AFP-300, AFP-400, MPS-6</b>	TB2-1	TB2-2
<b>APS-6R</b>	TB2 +	TB2 -
<b>FCPS-24</b>	TB4 +	TB4 -
<b>NCA</b>	TB1-2, TB1-3, or TB1-4	TB1-5, TB1-6, or TB1-7
<b>NFS-640</b>	TB7 Nonresettable 24VDC +	TB7 Nonresettable 24VDC -

**Figure 2-5 Supplying Power to the LCD-80**

## 2.5 Operating the LCD-80 in ACS Mode

The LCD-80 emulates from one to four ACM-16AT annunciators (one to two with the AFP-200). There is no change required by the control panel to operate the module in this mode.

The control panel sends commands to the LCD-80 to display alarm or trouble messages, and to print messages to the printer (if one has been installed). These messages are field-programmable and stored in LCD-80 memory for each point. Time and date is programmed into the LCD-80 and maintained by its own nonvolatile crystal clock.

In the ACS mode, the Acknowledge, Silence, and Reset switches may be enabled for system control (see DIP switch options). If these functions are enabled, access security must be provided by mounting the LCD-80 in:

1. A locked Fire Alarm Cabinet

OR

2. Annunciator Backbox model ABF-1/B or ABS-1T/B with AKS-1 key switch option.

### Acknowledge Switch\*

When the ACKNOWLEDGE switch is activated on the front panel, the LCD-80 sends an acknowledge command to the control panel over the EIA-485 interface, using the first switch position on the start annunciator address. The LCD-80 also silences its local sounder. An acknowledge message is printed on the local printer.

### Silence Switch\*

When the SILENCE switch is activated on the front panel, the LCD-80 sends a Signal Silence command to the control panel over the EIA-485 interface, using the second switch position on the start annunciator address. A SILENCE message is printed on the local printer.

### Reset Switch\*

When the RESET switch is activated on the front panel, the LCD-80 sends a System Reset command to the control panel over the EIA-485,

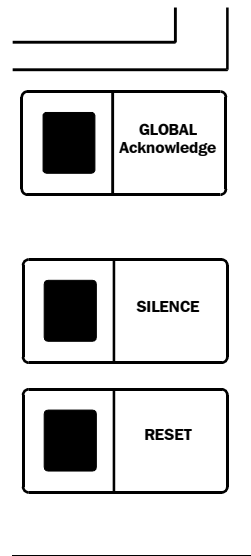

using the third switch position on the start annunciator address. A RESET message is printed on the local printer.

\*The Acknowledge, Silence, and Reset switch functions require programming from the AM2020 or AFP-1010.



The Acknowledge, Silence and Reset switches will serve no function if the LCD-80 has been set for Receive-Only operation (DIP switch SW1-1 has been set ON)

### **Time Select Switch**

This switch is used in conjunction with the TIME SET switch to set the time and date on the LCD-80. This switch is ignored if the system is in alarm. Under non-alarm conditions, the bottom display line will show the present time and date when this switch is pressed.

When the TIME SELECT switch is pressed, the left-most field (HOURS) will flash, indicating that it is ready to accept changes. Press the TIME SET switch to step through all possible values for that field. If the TIME SELECT switch is pressed again, the MINUTES field will flash, ready for changes. This continues through all time and date fields. If the switch is not pressed for one minute, or if the DISPLAY STEP switch is pressed, the LCD-80 will exit time/date select mode.

### **Time Set Switch**

When used in conjunction with the TIME SELECT switch, this switch sets the time and date into the LCD-80. This switch is ignored if the system is in alarm.

Once the TIME SELECT switch has been pressed, the TIME SET switch can be used to step through all possible values for that field. The new value is stored into the clock chip upon depression of either the Select or Display switch.

The Time Set switch can be used to adjust the contrast of the LCD-80's display

### **Display Step/Lamp Test Switch**

This switch may be used to step the display through multiple alarms or troubles. If both alarms and troubles exist in the LCD-80, DISPLAY STEP may be used to display the troubles (after first stepping through all alarms). This is a local function and does not send an acknowledge command to the control panel. If a trouble condition has turned off the backlighting, it also causes the backlit display to illuminate for about one minute, and while held, turns on all LCD segments (lamp test). The printer interface is not affected.







The 20-character option changes the custom point labels used in trouble reporting to a format similar to the 20-character alarm messages.

```
      01234567890123456789
ROW 2  <FIRST POINT LABEL>>
ROW 3  <<LAST POINT LABEL>>
ROW 4  XXALARM YYTROUBLES
```

Where “FIRST POINT LABEL” is the 20-character user-defined label for the first point to go into alarm. “LAST POINT LABEL” is the last alarm to occur in time. If there is only one alarm, row 3 is blank. The default label format is: “ZONE NNN (AXXPYY)”

## 2.6.4 Trouble Messages

When one or more troubles are reported to the LCD-80, and no alarms are reported, the following display format is used. If more than one trouble occurs, the LCD-80 shows the last trouble that occurred in time. One press of the ACK key acknowledges any number of troubles or new alarms (block acknowledge). When all alarms and troubles restore, the LCD-80 automatically restores to “ALL SYSTEMS NORMAL” without requiring ACK (self-restore).

```
      01234567890123456789
ROW 1  <<TROUBLE BANNER>>>>
ROW 2  <<<<<<<<CUSTOM POINT
ROW 3  LABEL>>>>>>>>>>>>>>>>
ROW 4  XXALARM YYTROUBLES
```

Where the “TROUBLE BANNER” is a user programmable 20-character field with a default value of “TROUBLE IN SYSTEM.”

The 20-character option changes the custom point labels used in trouble reporting to a format similar to the 20 character alarm messages described above.

*Supervisory Message:* If supervisory condition occurs, it is reported to the LCD-80 as both an alarm and a trouble from the same point (custom labels must be used to distinguish supervisories). The LCD-80 cannot distinguish the difference between supervisory and trouble conditions. The system programmer must differentiate supervisory conditions from trouble conditions when entering custom labels for the appropriate points.



6. When the SILENCE key is pressed the LCD-80 will print the following message:

```
<<<SILENCE BANNER>>>
  (line 2 blank)
  (line 3 blank)
HH:MM MM/DD/YY
```

Where the “SILENCE BANNER” is a user-programmable 20-character field with a default value of: “SIGNAL SILENCE.”

7. When the RESET key is pressed the LCD-80 will print the following message:

```
<<<<RESET BANNER>>>>
  (line 2 blank)
  (line 3 blank)
HH:MM MM/DD/YY
```

Where the “RESET BANNER” is a user-programmable 20-character field with a default value of: “SYSTEM RESET.”

## 2.6.7 Display Illumination

The LCD-80 display is backlit under normal conditions. Backlighting is shut off for all System 5000/System 500 panel trouble (other than Point Trouble), or for any trouble on the AM2020/AFP1010 (unless one or more alarms exist in this LCD-80).

In case of AC power loss, the backlight will go off to conserve battery power; it will operate for about 60 seconds whenever DISPLAY STEP is pressed.

## 2.7 Interface Operation

### 2.7.1 EIA-485 Interface

The EIA-485 interface generally emulates from one to four ACM-16AT annunciators, each with three expanders (64 points each). ACM-24AT, ACM-48, and their expanders should be set to 64-point operation. For compatibility with System 5000 and System 500, the

first eight points on an LCD-80 set for address 01 are used for the following functions:

<b>LCD-80 Point</b>	<b>Point Indication</b>	<b>Switch Function</b>
1	none	Acknowledge
2	none	Signal Silence
3	none	Reset
4	none	none
5	Notification Circuit 1 Trouble	none
6	Notification Circuit 2 Trouble	none
7	Remote Station Trouble	none
8	AC Fail	none

The Acknowledge, Signal Silence and Reset points must be programmed from the AM2020 or AFP1010 (DIP Switch SW1-4 must be set “OFF”).

**Note:** For AFP-200 details, refer to the Data Formats chart in the AFP-200 manual.

## 2.7.2 EIA-232 Interface

This interface is used to send information to a PRN printer in standard ASCII format. When the LCD-80 is in program mode, this interface is used to program the custom display messages and point labels.

## 2.7.3 Programming the LCD-80 (ACS Mode)

When employing the LCD-80 in ACS Mode, Program mode is used to enter custom messages and labels for annunciator points. Due to the nonvolatile memory onboard the LCD-80, this unit can be programmed anywhere, then removed for installation at another location. All programming will remain intact.

The LCD-80 can be programmed from either a CRT Monitor with keyboard or a standard communications program on an IBM-compatible personal computer. Either method requires the construction of a custom cable, as illustrated in Figure 2-6 and Figure 2-7.

### Programming outline:

- Remove 24 VDC power.
- Remove the LCD-80 from its mounting.

- Connect the EIA-232 interface to a CRT or personal computer.
- Reconnect 24 VDC power.
- Insert the PK-1 Programming Key onto connector P6.
- Program the LCD-80.
- Exit Program mode by removing the Programming Key.
- Reassembly is the opposite of disassembly.

### 2.7.4 Programming from the CRT Display Monitor

Programming the LCD-80 from the CRT requires a custom cable and a male DB-25 connector for connection to the display's EIA port. The CRT must also be configured as outlined on the next page.

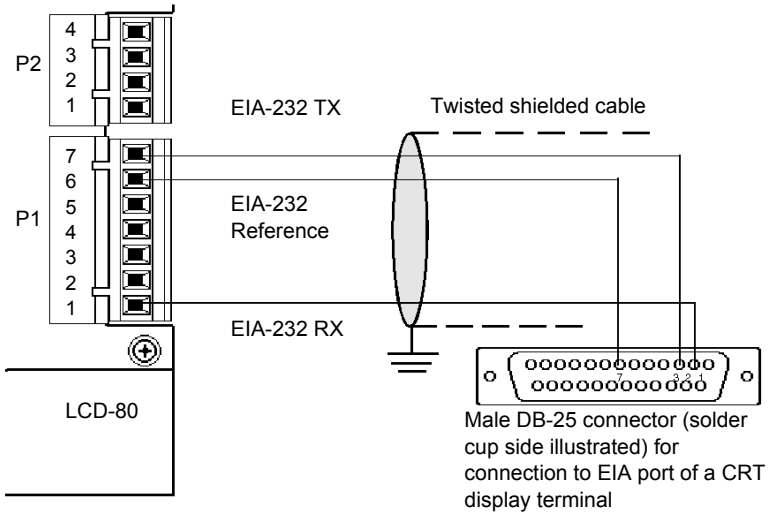





**Figure 2-6 LCD-80/CRT Connection**

**Note:** All EIA-232 circuit wiring to be power-limited and remain in same room.





## 2.7.5 Configuring the CRT for Programming the LCD-80

The CRT Monitor is programmed at the factory. These default settings will work for LCD-80; however, the CRT-2's function keys serve no purpose in programming the LCD-80 and need not be set up for this purpose. To change the factory set parameters, use the following procedure:

- Enter Setup Mode by pressing  and  simultaneously.
- Press Function Keys F1 through F13 to view the 13 separate groups of parameters. Use the arrow keys to move through each parameter within a group and use the space bar to view and select the options for each parameter.
- Upon completing the selection of all the parameters which are to be changed in all parameter groups:

- Press 
- Press  to save all changes.

To return to all the original factory default settings:

- Press 
- Using Arrow Keys, move to **RESET TERMINAL** menu item
- Press 
- Using Arrow Keys, move to **DEFAULT TERMINAL** menu item.
- Press 
- Press 
- Press  to save default settings.

## 2.7.6 Programming from an IBM-Compatible Computer

Programming the LCD-80 from an IBM-compatible computer requires a custom cable (P/N 75267); this cable provides a 9-pin female connector for connection to a serial port. If using a computer with a DB-25 connector, use DB9M-to-DB25F adapter (P/N 46029).

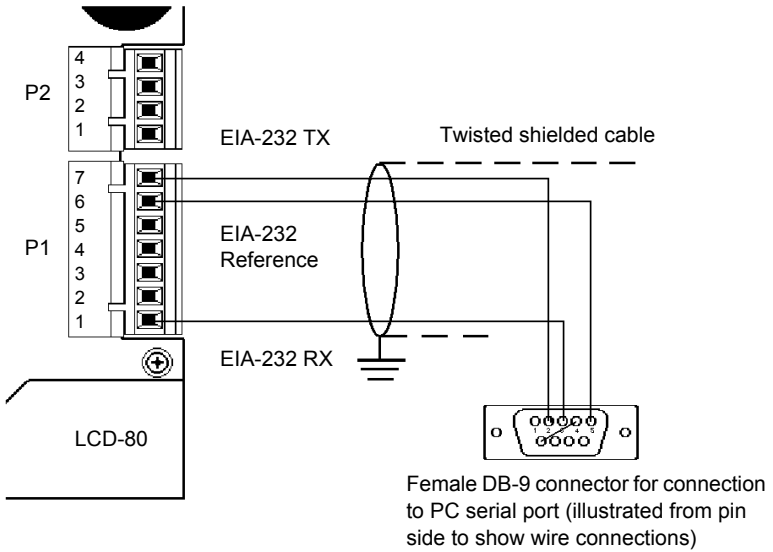

**Figure 2-7 LCD-80/IBM-compatible Connection**

LCD-80	DB-25	DB-9*
1	2	3
6	7	5
7	3	2

\*In the 9-pin connector housing, Pin 4 is connected to Pin 6.

**Table 2-4 Custom Cable Connections for Programming Cable**

PC Communications software used to program the LCD-80 must be used in “direct connect” or terminal mode and set for the following options:

- 2400 Baud.
- 7 Data Bits.
- 1 Stop Bits.
- Even Parity.
- XON/XOFF.

Note: If ProComm Plus is being used as the communications software to program the LCD-80, the Terminal Emulation must be set for TVI925.

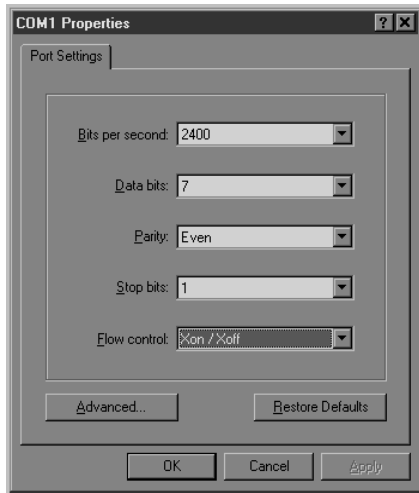

**Figure 2-8 HyperTerm for Microsoft® Windows 95™**

## 2.8 Default Messages and Point Labels

The LCD-80 contains default messages that can be restored (*en masse*) at any time. These messages can also be edited as needed. Note that any custom messages or labels that were previously entered will be overwritten by the default information and cannot be recovered.

Message	Characters	Text of Default Message
1	40	"FIRE ALARM SYSTEM ANUNCIATOR"
2	20	"ALL SYSTEMS NORMAL"
3	40	"COMMUNICATIONS FAIL"
4	20	"FIRE ALARM IN SYSTEM"
5	20	"TROUBLE IN SYSTEM"
6	20	"RETURN TO NORMAL"
7	20	"ACKNOWLEDGE"
8	20	"SIGNAL SILENCE"
9	20	"SYSTEM RESET"

Note: When the LCD-80 is used in conjunction with a combination



fire and security panel, the “FIRE” in default messages 1 and 4 must be removed.

To restore default messages:

- If in Program Mode, remove the Programming Key.
- Insert the Programming Key.
- Within several seconds after inserting the Programming Key, push in and hold in the DISPLAY STEP switch until the LCD-80 displays the following message:



```
TRANSFER DEFAULT  
CUSTOM MESSAGES  
TO NONVOLATILERAM
```

- Release the DISPLAY STEP switch and proceed with any additional programming required.

### To restore default point labels:

Use the above procedure with the following exception:

- Push TIME SET to restore 20-character default point labels.
- Push TIME SELECT to restore 40-character default point labels.
- Push ACK to restore 20-character default point labels for AIM-200 mode in the System 5000 (Revision 6 software required).

**Note:** Ensure that the choice of 20 or 40-character default labels matches the settings on the SIZE SELECT switches SW1-5 and SW1-6!

## 2.9 Entering Custom Messages

Once in Program mode, the LCD-80 ceases all communication on the EIA-485 and waits for commands from the EIA-232 circuit. The LCD-80 screen will display:

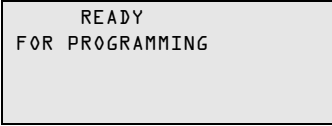

```
READY  
FOR PROGRAMMING
```

Configure the CRT or run a PC communications program and the respective monitor will display:

ENTER 1 to 9 FOR 9 CUSTOM MESSAGES OR 0 FOR CUSTOM POINT LABEL:

Any one of the nine custom messages may be programmed by pressing the respective number followed by ENTER on the keyboard. The LCD-80 screen and the display monitor will display either a default message or whatever message was last stored in the unit.

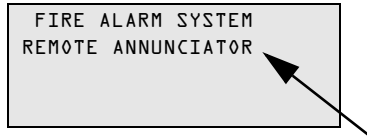

Text cannot be immediately entered since the cursor starts at the end of the message. The LCD-80 programmer must edit the message using the backspace key, then enter a new message.

Once the message has been edited, press ENTER to store the message. The screen will return to the display, “READY FOR PROGRAMMING.”

These custom messages have various character widths and are displayed under different conditions present within the fire alarm system.

Message Number	Conditions under which each message will be displayed
1	Standard display banner for the LCD-80.
2	Displayed under normal conditions.
3	Displayed when communications between LCD-80 and the control panel have been interrupted.
4	Displayed under all alarm conditions.
5	Displayed under all trouble conditions.
6	Messages 6 through 9 are not displayed on the LCD-80. These messages are sent to a printer connected to the LCD-80.
7	
8	
9	

## 2.10 Entering Custom Point Labels

Custom point labels may be programmed by entering “0” from the initial program prompt.

ENTER 1 to 9 FOR 9 CUSTOM MESSAGES OR 0 FOR CUSTOM POINT LABEL:0

A second prompt will be displayed on the CRT-1 or computer monitor.

### **LCD-80 set for 20-character labels:**

ENTER 1 to 256 FOR CUSTOM POINT LABEL (20 CHARACTERS):

where 1-256 represent zones in the control panel.

#### **Note:**

*System 5000* is limited to 128 points.

*AFP-200* uses Zones 1 to 99 only.

Once a point number has been entered, the LCD-80 screen will display either the custom zone message (illustrated below) or the last stored point message.

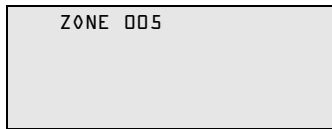

A rectangular LCD screen with a black border. The text "ZONE 005" is displayed in the upper left corner of the screen.

The label may be changed by backspacing over the existing label and typing a new one.

### **LCD-80 set for 20-character labels:**

ENTER 1 to 128 FOR CUSTOM POINT LABEL (40 CHARACTERS):

where 1-128 represent zones in the control panel.

#### **Note:**

*AFP-200* uses Zones 1 to 99 only.

Once a point number has been entered, the LCD-80 screen will display either the custom zone message (illustrated below) or the last stored point message.

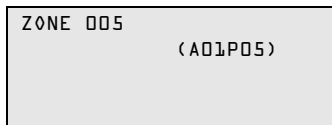

A rectangular LCD screen with a black border. The text "ZONE 005" is displayed in the upper left corner, and "(A01P05)" is displayed in the lower right corner.

In the 40-character mode, the default zone label contains the annunciator point address for this zone. This information is not necessary and may be erased if desired. Enter the desired zone label by backspacing out the existing label and typing a new one. Note that spaces can be added to center a label or message in the display window.

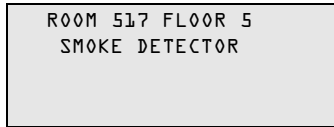

Once the message has been changed or entered satisfactorily, press ENTER to store the message. The LCD-80 screen will retain the previous point label information while the monitor display will return to the 40-character custom label prompt:

ENTER 1 to 128 FOR CUSTOM POINT LABEL (40 CHARACTERS):

Continue to enter point label information or press ESC to return to the initial programming prompt:

ENTER 1 to 9 FOR 9 CUSTOM MESSAGES OR 0 FOR CUSTOM POINT LABEL:

Once all programming of the LCD-80 has been completed, remove the Programming Key.

## Section 3 The LCD-80 & Terminal Mode

The LCD-80 set for Terminal Mode operates like a CRT terminal without full keyboard capability, but with the advantages of 24 VDC power, wall mount, and multiple terminal location with Acknowledge, Signal Silence and Reset.

For AFP-200, AFP-300, AFP-400, AFC-600, AM2020/AFP1010, NFS-640, and NCA, Terminal Mode is preferable to the ACS Mode because it has full point-display capacity, and because it requires no programming.

**Note:** LCD-80 terminal mode is not supported by System 500 or System 5000.

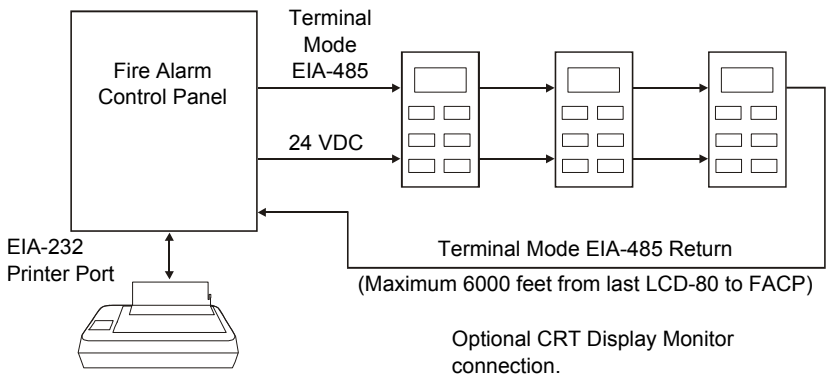

### Notes:

- EIA-485 circuits have a maximum of 6000 feet between units.
- Up to 32 LCD-80s may be used on the EIA-485 circuit (3.2 amps regulated power max required - consult control panel's battery calculations. Note: When powered by the AFP-200, a maximum of four LCD-80s may be connected to this circuit.
- Between each LCD-80 are four wires: A twisted-shielded pair for data communications and an open pair for 24 VDC power. The return circuit only requires two wires for data communication.
- The EIA-485 interface used in Terminal Mode should not be confused with the EIA-485 circuit used in ACS Mode (annunciator interface). With AM2020/AFP1010, the CCM-1 Converter Module converts the EIA-232 Terminal Interface from the SIB-2048 into the EIA-485 standard required by the LCD-80. A separate EIA-485 circuit for powering ACS or LDM Series annunciators can be taken off of the SIB-2048 Serial Interface

Board. The DIA-2020N can support LCD-80s in terminal mode without the need for a CCM-1 converter module, provided no CRT is installed on the SIB.

- The EIA-485 terminal interface does not support the use of RPT-485 repeaters. The RPT-485 repeater can only be used to extend the ACS EIA-485 circuit.

**8-position DIP switch (SW1)**

- 1) Not used.
- 2) Not used.
- 3) Set "ON" to disable Piezo.
- 4) Set "ON" to disable Acknowledge, Signal Silence and Reset switches.
- 5) Not used.
- 6) Not used.
- 7) Set "ON" in this mode.
- 8) Not used.

**SW2** - Not used in **TERMINAL** Mode.

**Last LCD-80 Options (SW3)**

These switches should be set "OFF" for all LCD-80's except the last on the EIA-485 loop.

- 1) Set "ON" for the last LCD-80.
- 2) Terminal Supervision - set "ON" to supervise the EIA-485 loop. Terminal supervision must also be enabled during programming of the FACP.

**Programming Key Interface**

2-pin connector compatible with PK-1 program key.

**AKS-1 Keyswitch Interface**

Connect to optional keyswitch.

**Operation mode Slide Switches**

Set both switches in the DOWN position (RAA 2020) for *Terminal* Mode.

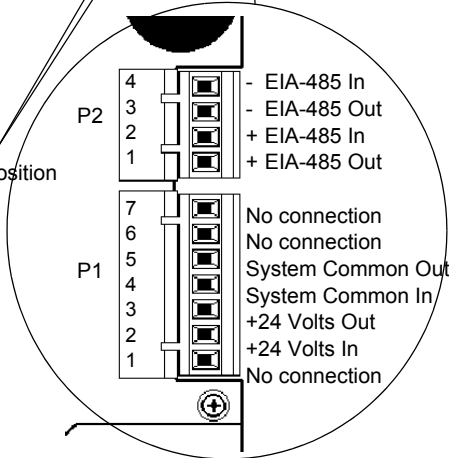
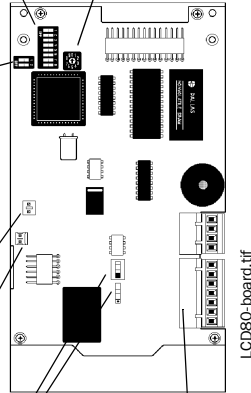

**Terminal Mode Connections**

**Figure 3-1 Configuring the LCD-80 for TERMINAL Mode**

**Note:** Section 1.3 lists panels that support Terminal Mode.

## 3.1 Operating the LCD-80 in Terminal Mode

### 3.1.1 Display Patterns

The LCD-80 displays directly the information from the FACP terminal interface without alteration. Note: The ALARMS PENDING, TROUBLES PENDING, Alarm Count and Trouble Count information will not be displayed on the LCD-80.

If the LCD-80 fails to receive communications from the panel for a period of over one minute, it will activate its local sounder and display the following message:

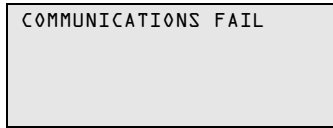

### Printer Operation

The LCD-80 does not support a remote printer when operating in Terminal Mode.

### 3.1.2 Switch Functions in Terminal Mode

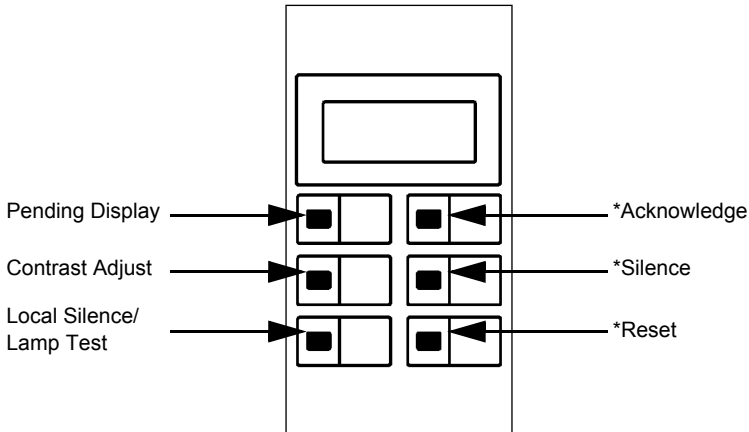

\*Note: If Acknowledge, Silence, and Reset switches are enabled for system control, access security must be provided by mounting the LCD-80 in a locked fire alarm cabinet, or annunciator backbox model ABF-1/B or ABS-1T/B with AKS-1 key switch option.



### **Acknowledge/Step Switch**

When the ACK/STEP switch is pressed on the front panel, the LCD-80 sends an Acknowledge command to the control panel, emulating a CRT terminal.

### **Silence Switch**

When the SILENCE switch is pressed on the front panel, the LCD-80 sends a Signal Silence command to the control panel, emulating the CRT terminal.

### **System Reset Switch**

When the System Reset switch is pressed on the front panel, the LCD-80 sends a Reset command to the control panel, emulating the CRT terminal.

### **Pending Display**

The LCD-80 will keep a count of alarms in the system (number of alarm messages, minus alarm clear messages, since the last ALL SYSTEMS NORMAL message). When this key is pressed the alarm count is displayed in place of the time/date for 10 seconds. AM2020/AFP1010 Note: This feature requires Revision 5 software or greater.

### **Contrast Adjust**

Repeatedly press this switch until the display's contrast is acceptable.

### **Local Silence/Lamp Test Switch**

If the backlit LCD display has been turned off due to a trouble condition in the system, pressing this switch will illuminate the display for 60 seconds. This switch also silences the local piezo. While it is held down, all segments on the display will be turned on and the piezo will sound.

## **3.1.3 Terminal Mode EIA-485 Connection Requirements**

See Figure 3-2 for wiring diagram; the following requirements must be observed:

- Power-limited and supervised.
- Maximum of 32 LCD-80s may be connected to this circuit. Note: When powered by the AFP-200, a maximum of four LCD-80s may be connected to this circuit.
- 6000 feet maximum distance (@ 16 AWG) between the control panel and the first or last LCD-80 and between each LCD-80.
- Use overall foil/braided-shield twisted pair cable suitable for EIA-485 applications.

- EIA-485 circuit rated 5.5 VDC max., 60 mA max.
- Each LCD-80 must have R-120 resistors installed across the in and out terminals as shown in Figure 3-2.
- Set SW2 on the AFP-200 to the “Term” position (left-hand position).
- Set SW4 and 5 on the LCD-80 to the “Term” position: SW1-7 “On”.
- The LCD-80s require connection of operating power! Connect 24 V power to the onresettable power connections on the panel, or other appropriate power source as defined in Section 2.4 “Power Connections”.

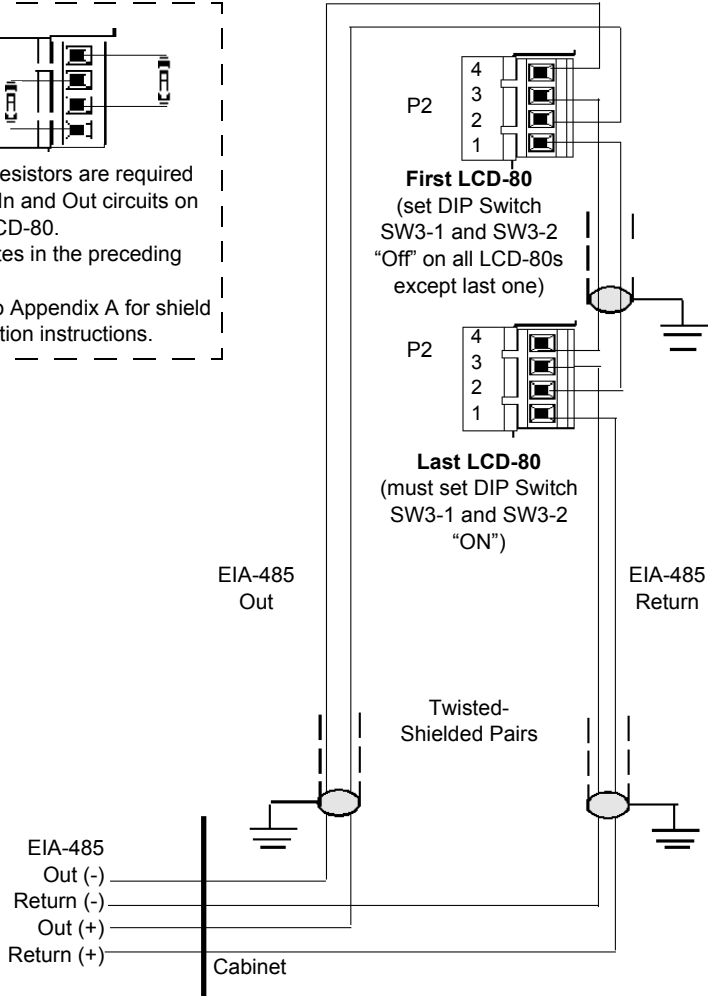
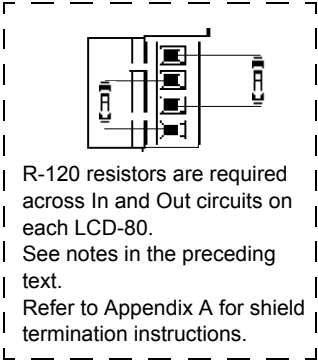

\*See notes in preceding text.

**Figure 3-2 Terminal Mode EIA-485 Connection**

<b>EIA-485 Connections on LCD-80</b>	<b>CCM-1 (AM2020/ AFP1010)</b>	<b>AFP-200</b>	<b>DIA (AM2020/ AFP1010)</b>	<b>NFS-640</b>	<b>AFP-300, AFP-400, AFC-600</b>
OUT(-)	P3-4	TB5-2	TB1-4	TB12	TB3-4
RET (-)	P3-3	TB5-4	TB1-3	TB12	TB3-2
OUT(+)	P3-2	TB5-1	TB1-2	TB12	TB3-3
RET (+)	P3-1	TB5-3	TB1-1	TB12	TB3-1

**Table 3-1 EIA-485 Control Panel Connections (Terminal Mode)**

# APPENDIX A EIA-485 Shield Terminations

The EIA-485 circuit must be wired using a twisted-shielded pair cable having a Characteristic Impedance of 120 ohms, +/- 20%. Do not run cable adjacent to, or in the same conduit as, 120-volt AC service, noisy electrical circuits that are powering mechanical bells or horns, audio circuits above 25 Vrms, motor control circuits, or SCR power circuits. *All enclosures, including the FACP backbox, must be connected to earth ground! Never use the shield for grounding purposes.*

## **When employing the LCD-80 in ACS Mode:**

Terminate the EIA-485 shield at the Fire Alarm Control Panel only.

When the EIA-485 shield is in conduit: Connect it to system reference (system common). The shield can enter the cabinet, but must be insulated from the cabinet (not electrical contact). Between LCD-80s, wire-nut multiple shields together (which can be inside of the respective enclosure).

When the EIA-485 shield is not in conduit: Terminate the shield at the outside of the FACP backbox (ground). Do not allow the shield to enter or even touch the cabinet. Between LCD-80s, wire-nut multiple shields together outside of the respective enclosures.

## **Note on remote power supplies:**

When the LCD-80 is powered from a separate power supply, use a separate conductor to connect the main power supply common terminal to the remote power supply common terminal. Disable earth fault detection on the remote power supply. AM2020/AFP1010 and System 5000s with an AIM-200 installed would require an MPS-24A (or an MPS-24B with an EFB-1 installed) in its main cabinet.

## **When employing the LCD-80 in Terminal Mode:**

Terminate the EIA-485 shields at either the cabinet (when not in conduit) or at system common (when in conduit) as outlined below.

AM2020/AFP-1010 Note: Terminate EIA-485 shields at both the Out and Return ends of the CCM-1, DIA-1010 or DIA-2020.

When the EIA-485 shield is not in conduit: At each respective LCD-80 enclosure (except the first on the loop), terminate the shield coming in from the previous LCD-80 at the outside of the cabinet backbox (earth ground). Let the outgoing (to next LCD-80) shield float (no connection). Shield termination between LCD-80s can only occur at the receiving end - the end connected to P1 Terminals 2

and 4. AM2020/AFP1010 Note: For the first LCD-80 on the loop, let the shield coming in from the CCM-1 or DIA float.

When the EIA-485 shield is in conduit: At each respective LCD-80 enclosure (except the first on the loop), terminate the shield coming in from the previous LCD-80 at system common. Let the shield going out to next LCD-80 shield float (no connection). Shield termination between LCD-80s can only occur at the receiving end—the end connected to LCD-80 P1 Terminals 2 and 4. AM2020/AFP1010 Note: For the first LCD-80 on the loop, let the shield coming in from the CCM-1 or DIA float.

# APPENDIX B AIM-200 Point Annunciation

The CPU-5000 can be programmed for an alternate method of annunciating the AIM-200. Up to 192 intelligent devices can be annunciated on a single LCD-80 annunciator. The System 5000 annunciates the AIM-200 installed directly to the right of the CPU-5000. Note that an annunciator cannot be used to execute manual ON/OFF control of intelligent AIM-200 points only standard System 5000 zones. The option provides annunciation of up to 256 points for the System 5000, broken down as follows:

## Annunciator Address 1:

- 8 CPU points (CPU point shift not an option).
- 8 unusable points (redundant AIM-200 points).
- 48 points mapped to the next six modules installed in the System 5000 (which can also be AIM-200s for annunciation of their 8 software zones).

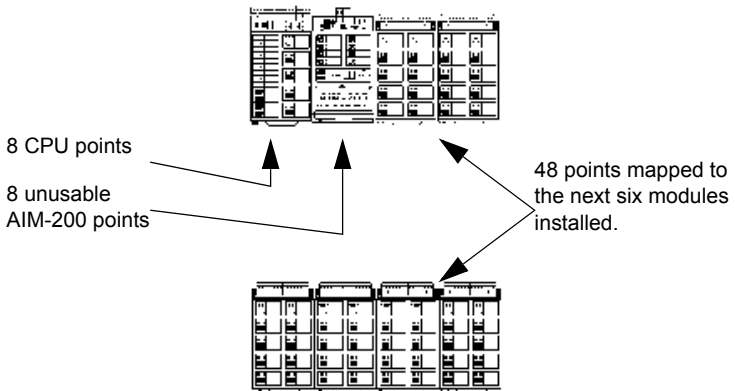

## Annunciator Address 2

Intelligent Detectors, addressed 1-64, on the AIM-200 installed next to the CPU-5000.

### **Annunciator Address 3**

Addressable Modules, addressed 1-64, on the AIM-200 installed next to the CPU-5000.

### **Annunciator Address 4**

Intelligent Detectors, addressed 65-96, followed by Addressable Modules, addressed 65-96, on the AIM-200 installed next to the CPU-5000.

The System 5000 Programming Manual, Document 15584, provides programming instructions for this option. Refer to program choice "AIM(256)."

Note: AIM-200 detector and module addresses 97, 98 and 99 may be used, but cannot be point-annunciated.

Annunciator Address	AIM-200 Points	LCD-80 Points
01	1-64 system points	1-64
02	1-64 AIM detectors	65-128
03	1-64 AIM modules	129-192
04	65-96 detectors 65-96 modules	193-224 225-256

**Table C-1 Comparison Report - AIM-200 vs. LCD-80**



# Notes

# Notes

## Limited Warranty

**NOTIFIER®** warrants its products to be free from defects in materials and workmanship for eighteen (18) months from the date of manufacture, under normal use and service. Products are date stamped at time of manufacture. The sole and exclusive obligation of **NOTIFIER®** is to repair or replace, at its option, free of charge for parts and labor, any part which is defective in materials or workmanship under normal use and service. For products not under **NOTIFIER®** manufacturing date-stamp control, the warranty is eighteen (18) months from date of original purchase by **NOTIFIER®**'s distributor unless the installation instructions or catalog sets forth a shorter period, in which case the shorter period shall apply. This warranty is void if the product is altered, repaired or serviced by anyone other than **NOTIFIER®** or its authorized distributors or if there is a failure to maintain the products and systems in which they operate in a proper and workable manner. In case of defect, secure a Return Material Authorization form from our customer service department. Return product, transportation prepaid, to **NOTIFIER®**, 12 Clintonville Road, Northford, Connecticut 06472-1653.

This writing constitutes the only warranty made by **NOTIFIER®** with respect to its products. **NOTIFIER®** does not represent that its products will prevent any loss by fire or otherwise, or that its products will in all cases provide the protection for which they are installed or intended. Buyer acknowledges that **NOTIFIER®** is not an insurer and assumes no risk for loss or damages or the cost of any inconvenience, transportation, damage, misuse, abuse, accident or similar incident.

**NOTIFIER®** GIVES NO WARRANTY, EXPRESSED OR IMPLIED, OF MERCHANTABILITY, FITNESS FOR ANY PARTICULAR PURPOSE, OR OTHERWISE WHICH EXTEND BEYOND THE DESCRIPTION ON THE FACE HEREOF. UNDER NO CIRCUMSTANCES SHALL **NOTIFIER®** BE LIABLE FOR ANY LOSS OF OR DAMAGE TO PROPERTY, DIRECT, INCIDENTAL OR CONSEQUENTIAL, ARISING OUT OF THE USE OF, OR INABILITY TO USE **NOTIFIER®** PRODUCTS. FURTHERMORE, **NOTIFIER®** SHALL NOT BE LIABLE FOR ANY PERSONAL INJURY OR DEATH WHICH MAY ARISE IN THE COURSE OF, OR AS A RESULT OF, PERSONAL, COMMERCIAL OR INDUSTRIAL USE OF ITS PRODUCTS.

This warranty replaces all previous warranties and is the only warranty made by **NOTIFIER®**. No increase or alteration, written or verbal, of the obligation of this warranty is authorized.

"**NOTIFIER**" is a registered trademark.

Warn-NS-10-2001.fm



World Headquarters  
12 Clintonville Road  
Northford, CT 06472-1653 USA  
203-484-7161  
fax 203-484-7118

[www.notifier.com](http://www.notifier.com)

NOTIFIER is a **Honeywell** company.

**ISO 9001**  
CERTIFIED  
ENGINEERING & MANUFACTURING

## ACS Mode Labels

## Terminal Mode Labels

<b>TIME SELECT</b>	<b>GLOBAL ACKNOWLEDGE</b>		<b>GLOBAL ACKNOWLEDGE</b>
<b>TIME SET</b>	<b>SILENCE</b>	<b>CONTRAST ADJUST</b>	<b>SILENCE</b>
<b>CONTRAST ADJ.</b>			
<b>DISPLAY STEP</b> Local Acknowledge	<b>RESET</b>	<b>HOLD FOR LAMP TEST</b>	<b>RESET</b>
<b>HOLD FOR LAMP TEST</b>			
<b>ACS Mode Label (left)</b>	<b>ACS Mode Label (right)</b>	<b>Terminal Mode Label (left)</b>	<b>Terminal Mode Label (right)</b>

*If the Acknowledge, Silence and Reset switches have been disabled, insert the right-hand label with blank side facing out.*