

# SIEMENS

## Installation Instructions

Model MOM-4

Optional Card Cage Module

### OPERATION

The Model MOM-4 Card Cage board (See Figure 1) provides the MXL/MXLV/MXL-IQ with four card slots for optional modules. Each MOM-4 has space for two full-width optional modules or four half-width modules, or a combination of one full and two half-width optional modules. The MOM-4 comes with four card guides for mounting two full-width modules. The half-width modules come with the necessary extra card guides for mounting them.

**NOTE:** The MME-3 enclosure has up to three locations for the MOM-4 (or for OMM-1s, OMM-2s, or MOM-2s). **However, when a TSP-40 printer is installed in an enclosure, it decreases the number of MOM-4s to a maximum of two modules in that enclosure.**

The MSE-3L has one location for the MOM-4.

The MOM-4 provides two power connector receptacles, two power connection terminal blocks, and two data connector receptacles. A 24 VDC cable that provides the main power used by the optional modules and an 8-wire ribbon cable for connection of 5 VDC and data lines are provided with the MOM-4 installation kit.

**NOTE:** TB5 is 24 VDC **output** only, with a maximum of 2A.

### INSTALLATION

**Remove all system power before installation, first battery and then AC.**  
(To power up, connect the AC first, then the battery.)

Unpack the MOM-4 and its attached backplate. Inspect it, looking for such things as connectors not properly installed, dirt, and packing material on the board.

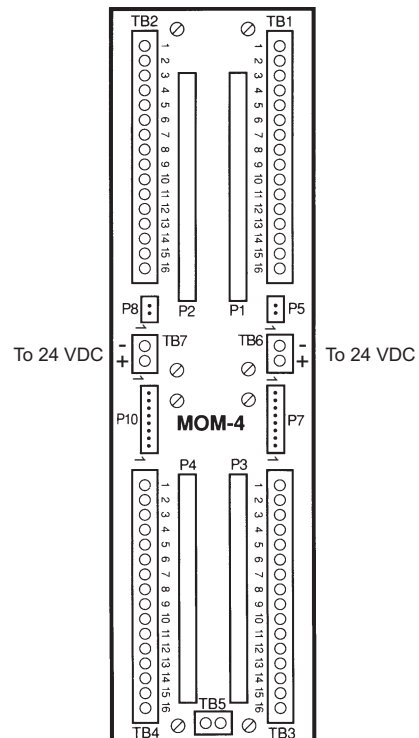

**Figure 1**  
**MOM-4 Card Cage**

The installation kit for the MOM-4 includes the following items:

- Four #10 nuts
- Four #10 flat washers
- Four #10 lockwashers
- Four card guides
- One 2-wire cable (P/N 555-190969)
- Two 8-conductor ribbon cables (P/N 555-190967 and P/N 555-193344)

## Mounting

(Refer to Figure 2)

### To mount the MOM-4 card cage in an MME-3 enclosure:

The MOM-4 mounts vertically on the lower portion of the MBR-MP mounting plate under the MMB or the PSR on the four studs provided as shown in Figure 2.

1. Place the module on the mounting studs in the left-hand position of the mounting plate.
2. Fasten the MOM-4 in position with the hardware provided, as shown in Figure 2.
3. To mount any other MOM-4 modules used in the system, repeat the above steps. Use the center or right-hand position for the additional modules as needed.
4. Once the MOM-4 is secured, install the four card guides included in the package.

### To mount the MOM-4 card cage in an MSE-3L enclosure:

1. Place the module vertically on the mounting studs near the top left of the enclosure as shown in Figure 3.
2. Fasten the MOM-4 in position with the hardware provided.

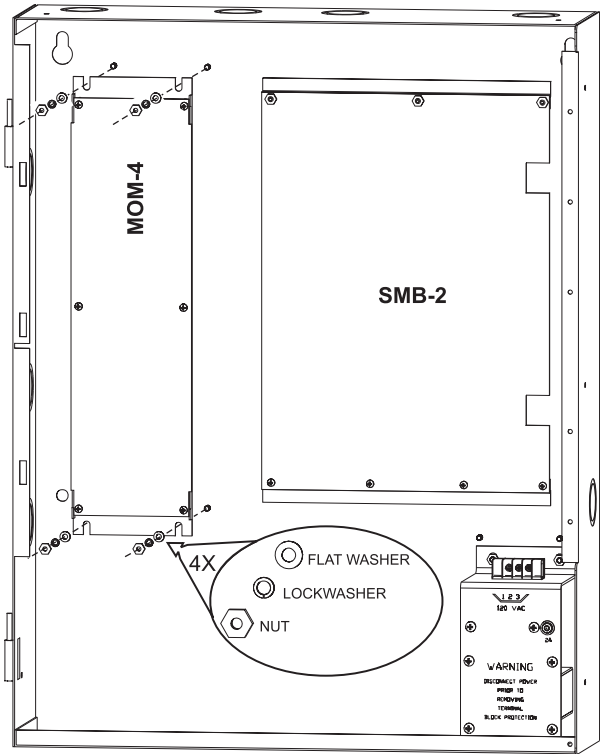

**Figure 3**  
Mounting the MOM-4 in an MSE-3L Enclosure

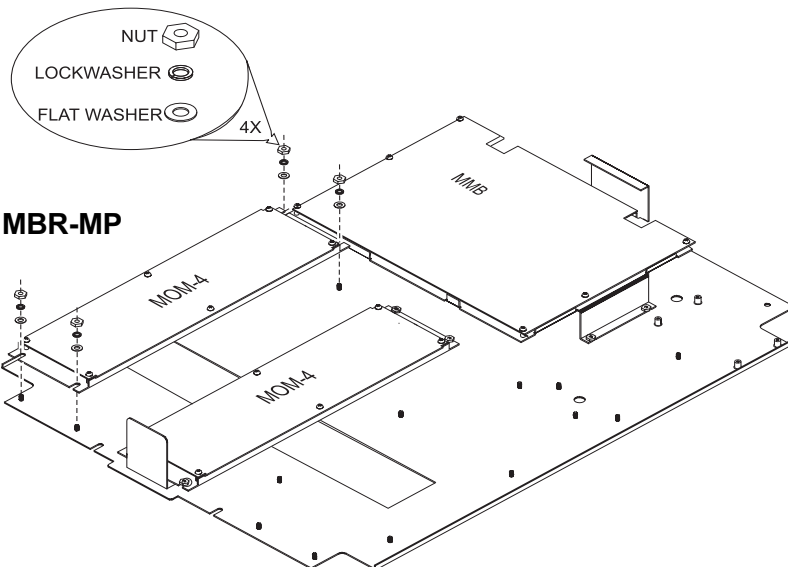

**Figure 2**  
Mounting the MOM-4 on an MBR-MP Mounting Plate

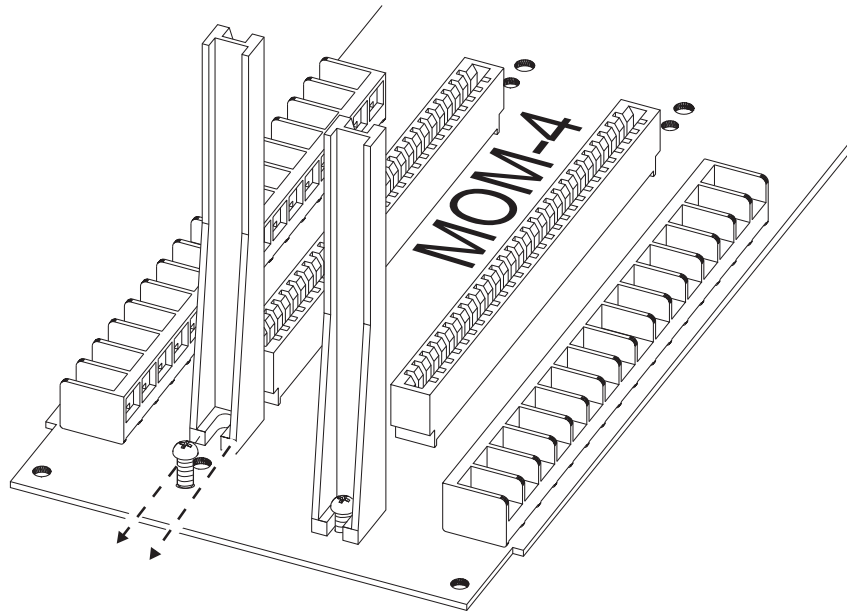

**Figure 4**  
**Installing the Card Guides in the MOM-4**

**To install the card guides (See Figure 4):**

Once the MOM-4 is secured, install the four card guides included in the package. Mount the four card guides to the positions shown in Figure 4. The MOM-4 is shipped with mounting screws for the card guides already installed.

1. Slip the slot in the base of the card guide under one of the mounting screws.
2. Make sure that the locating pin on the guide is seated in the hole on the MOM-4.
3. Tighten the screw.

Repeat this process for the remaining card guides. The MOM-4 is now ready to accept the optional modules.

**Electrical Installation**

There are two inputs that connect the MOM-4 with the MMB or SMB. These inputs provide all the necessary power and data lines to support the optional modules.

The first input is an 8-conductor ribbon cable. Attach the cable to P6 on the MMB or SMB, making sure that the locking rib on the cable connector engages the locking tab on P6.

Attach the other end of the cable to P10 on the MOM-4, again making sure that the locking rib of the cable engages the locking tab on P10. This cable supplies 5 VDC and communication between the MMB or SMB and the MOM-4.

The second input feeds 24 VDC full wave unfiltered DC to the MOM-4. This input connects to either P8 (MMB-1 or SMB-1 only) or TB6. A 2-wire cable is provided for backward compatibility with the MMB-1 or SMB-1. Connect one end of the cable to P3 on the MMB-1 or SMB-1, making sure the cable rib and board tab lock. Attach the other end of the cable to P8 on the MOM-4 in the same way.

When the 24 VDC is provided by either the MMB-2 or SMB-2 or the PSR-1, use TB6 on the MOM-4 to connect the power. The wire for this connection is not supplied (See *MMB-2 Installation Instructions*, P/N 315-095097, or *PSR-1 Installation Instructions*, P/N 315-090911, for terminal connections.)

The power source on the MOM-4 is limited to 2A max by the MMB-1 or SMB-1. Under maximum load conditions, the optional modules must never draw more than 2A from this connection.

When the 24 VDC is provided by either the MMB-2/-3 or SMB-2, use TB6 on the MOM-4 to connect the power. The wire for this connection is not supplied (See the *MMB-2 Installation Instructions*, P/N 315-095097, the *MMB-3 Installation Instructions*, P/N 315-048860 or the *SMB-2 Installation Instructions*, P/N 315-095931).

When the system includes an MMB-2/-3 or SMB-2, the maximum load current for the MOM-4 is 6A when using an MPS-6 and 12 amps when using an MPS-12. However, the 6A must be reduced by the amount of current being used by the CZM-1, PS-5A/-5N7, and NAC outputs. Thus, if the full 1A available to the CZM-1 and PS-5A/-5N7, and the 3A available to the NAC outputs are used, derate the MOM-4 current to 2 amps (or, if an MPS-12 is used, derate the MOM-4 current to 8A).

When the 24 VDC is provided by PSR-1, use TB6 on the MOM-4 to connect the power. The wire for this connection is not supplied (See the *PSR-1 Installation Instructions*, P/N 315-090911, for terminal connections).

When the system includes a PSR-1, the maximum load current for the MOM-4 is 6A when using an MPS-6 and 12 amps when using an MPS-12. However, the 6A must be reduced by the amount of current being used by the CZM-1 and PS-5A/-5N7 output. Thus, if the full 2A available to the CZM-1 and PS-5A/-5N7 are used, derate the MOM-4 current to 4A (or, if an MPS-12 is used, derate the MOM-4 current to 10A).

Depending on the optional modules installed, additional power may be available at TB5 and for notification appliances. See Table 1 for the maximum current required by each module under full load conditions.

Determine which optional plug-in modules are used in your CSG-M configuration. Depending on the optional modules used, determine the outstanding power by using Table 1 (See the **EXAMPLE**). This power can be used for notification appliances or for the optional power connector on TB5.

**TABLE 1**  
**MAXIMUM MODULE LOAD CURRENTS**

<b>ALD-2I</b>	105mA + 1.1mA per device
<b>CMI-300</b>	96mA
<b>CRM-4</b>	75mA (4 relays energized)
<b>CSM-4</b>	34mA (no notification appliances connected)
<b>CZM-4</b>	720mA max (with 4 zones in alarm)
<b>NIM-1R/1W</b>	0mA
<b>REP-1</b>	150mA
<b>XLD-1</b>	395mA (120 devices in alarm)

**NOTE:** When a CSM-4 is used, you may add notification appliances to it if the maximum load current to the MOM-4 does not exceed 2 amps (MMB-1 or SMB-1) or with an MMB-2/-3, SMB-2, or PSR-1, 6 amps (MPS-6) or 12 amps (MPS-12). Include the total alarm current on each CSM-4 notification appliance circuit when performing the calculations.

**EXAMPLE:**

With: one CRM-4 and one CSM-4  
Total load current = 0.075 + 0.034 = 0.109A

**With MPS-6:**

Remaining Available Current =  
2.0 - 0.109 = 1.891A (MMB-1 or SMB-1)  
6.0 - 0.109 = 5.891A (PSR-1 / MMB-2/-3 / SMB-2)  
with no CZM-1, PS-5A/-5N7, or NAC load

**With MPS-12:**

Remaining Available Current =  
2.0 - 0.109 = 1.891 (MMB-1 or SMB-1)  
12.0 - 0.109 = 11.891 (PSR-1 / MMB-2/-3 / SMB-2)  
with no CZM-1, PS-5A/-5N7, or NAC load

The remaining current may be used for alarm notification appliances.