



If the fire alarm system is connected to a central station or fire department, or operates external devices such as fans, extinguishers, etc., connected, notify appropriate personnel and disconnect the external devices until all tests are completed. After testing, reset the system, reconnect the devices, and notify the personnel that the system is operating again.

#### ELECTRICAL RATINGS FOR PE-11

Voltage	16-27 VDC
Ripple	3V peak-to-peak
Supervisory Current	110 uA max.
Start-up Time	50 seconds max.
Alarm Current	33 - 50mA

#### ELECTRICAL RATINGS FOR AD2-4W

INPUT CURRENT	STANDBY CURRENT (Typical)	ALARM CURRENT (Typical)	TROUBLE CURRENT (Typical)
24VDC	29mA	123mA	20mA
24VAC @ 60Hz	80mA	273mA	65mA
115VAC @ 60Hz	26mA	57mA	35mA
230VAC @ 60Hz	30mA	38mA	20mA

#### REMOTE ACCESSORIES

The accessories available for use with AD2-4W are:

REMOTE ACCESSORIES		PILOT LED (Green)	ALARM LED (Red)	TROUBLE LED (Yellow)	HORN	ELECTRICAL RATINGS		
MODEL	DESCRIPTION					STANDBY	ALARM	TROUBLE
MS-KA/P/R	Remote Alarm, Pilot, key-operated Test/Reset Switch	●	●			15mA	35mA	0mA
MS-RA/P	Remote Alarm, Pilot	●	●			15mA	35mA	0mA
MS-RH/KA/P/A/T	Remote Alarm, Trouble, Pilot, Horn, key-operated Test/Reset Switch	●	●	●	●	15mA	55mA	15mA

MSR-100R/R	Remote Indicator / Control Assembly / Red Single Gang Coverplate					15mA	50mA	55mA
MSR-100R/W	Remote Indicator / Control Assembly / White Single Gang Coverplate					15mA	50mA	55mA

SMOKE TEST GAS	
TG-11	Detector Test Gas
AD-TGN	Test Gas Nozzle Kit

SMOKE DETECTOR HEAD	
500-094150	PE-11 Photoelectric Detector

Siemens Industry, Inc.  
Building Technologies Division  
Florham Park, NJ

Siemens Building Technologies, Ltd.  
Fire Safety & Security Products  
2 Kenview Boulevard  
Brampton, Ontario L6T 5E4 Canada

P/N 315-049709-3

# SIEMENS

## Installation Instructions

### Model AD2-4W

#### Air Duct Monitoring Housing

#### INTRODUCTION

Model AD2-4W from Siemens Industry, Inc., is an air duct monitoring housing containing sampling tubes. When used with a PE-11 smoke detector, smoke and combustion products are detected for shutdown of the duct system and/or operation of supplementary equipment as provided by the system control panel. The duct unit supports two sets of Form C alarm contacts, one Form A alarm contact and one Form C trouble contact. The trouble contact supervises the presence of the input power, removal of the detector cover and the removal of the smoke detector head.

#### TECHNICAL DATA

#### AIR DUCT CONDITIONS

##### Temperature Range:

32°F (0°C) - 100°F (38°C) per UL 268A

##### Altitude Range:

No altitude limitations

##### Relative Humidity:

Up to 85% RH (non-condensing/non-freezing)

##### Air Duct Velocity Range:

100-4000 ft/min

##### Sampling and Exhaust Tube Pressure Differential Range:

Greater than 0.01 and less than 1.2 inches of water column



These air duct detectors are designed for detection and control of products of combustion in a duct system. **They are not to be used as a substitution for open area protection.** DO NOT USE air duct detectors with Alarm Verification.

#### ASSEMBLY

This detector has a cover tamper (removal) switch. Care should be taken when installing the cover. Squarely place the cover on the unit to avoid possible damage to the switch.



**DO NOT SLIDE COVER INTO POSITION.**

P/N 315-049709-3

Siemens Industry, Inc.  
Building Technologies Division

## APPLICATION

The AD2-4W duct smoke detectors provide early detection of smoke and products of combustion present in air moving through an HVAC duct supply, return, or both. These devices are designed to prevent the recirculation of smoke in areas by the air handling system's fans and blowers and may be used with fire alarm systems that shut down complete air handling system in the event of smoke detection.



*For the correct installation of a duct smoke unit please refer to NFPA 72 (National Fire Alarm Code), NFPA 90A (Standard for Installation of Air Conditioning and Ventilation Systems), and NFPA 92A (Recommended Practice for Smoke Control Systems).*

This detector is not intended for open area protection nor should it be used for early warning detection or to replace a regular fire detection system.

## OPERATION

When the Model AD2-4W is operating, a sample of air is drawn from the duct and passed through the sampling chamber by means of the input sampling tube. The air sample passes through the smoke detector mounted in the duct housing and is exhausted back into the duct through the outlet tube.

- The AD2-4W supports two sets of Form C alarm contacts, one Form A alarm contact and one Form C trouble contact. The trouble contact supervises the presence of the input power, removal of the detector cover and the removal of the smoke detector head.
- The AD2-4W contains a green power on LED, red alarm LED and yellow trouble LED which are visible through the housing cover.
- The trouble LED is activated when either the housing cover or smoke detector is removed from the unit.
- When the trouble LED is activated, the power LED turns off.
- A reset/test switch is located on the housing cover and is used to reset the unit after an alarm and the smoke condition is cleared. When not in alarm, the reset/test switch can be used to test that the unit will operate properly when an alarm condition exists.

The trouble contacts will not operate in the event of a smoke alarm. The AD2-4W duct detector will operate from various input voltage sources; namely 24VAC, 24VDC, 115VAC and 230VAC.



**DO NOT SPRAY GAS FOR MORE THAN ½ SECOND. OVER-USE OF TEST GAS MAY RESULT IN DETECTOR CONTAMINATION.**

After 15 to 20 seconds the detector will go into alarm, illuminating the detector LED and causing the duct unit functions to operate; alarm relays will change state, and the alarm related remote accessories, if attached, will function.

If no test gas is available to conduct functional testing, remove cover and, while holding down the cover removal switch, blow smoke from a smoldering cotton wick or punk directly at the head to cause an alarm. The alarm indicator on the detector should illuminate within one minute.

Refer to the PE-11 Installation Instructions, P/N 315-094198, for additional information on testing these detectors.

## MAINTENANCE

This detector is equipped with cover removal switch (SW1) that instantly provides a trouble condition upon removal of the clear cover. For all testing and inspection with the cover removed, the cover removal switch (designated as SW1 on PCB) must be manually depressed to simulate normal operation.

The performance of the air duct detector unit may be adversely affected by dirt or foreign matter on the sampling tubes or detector. If the air holes in the input sampling tube become restricted, the unit cannot receive a proper air sample, and performance is impaired. It is recommended that the sampling tubes be checked and cleaned periodically. The detector maintenance program should consist of periodic cleaning of dust from the detector head by using a vacuum cleaner. For cleaning the PE-11, refer to the detector's Installation Instructions, P/N 315-094198.

The cleaning and test program is recommended for 6 month intervals, or more frequently, if needed, depending on the individual detector environment. Consult your local code and AHJ requirements for required maintenance schedules.



**Under no circumstances is the detector portion of the unit to be disassembled by anyone other than an authorized Siemens Industry, Inc. Systems Technician. For service, contact your nearest authorized Siemens Industry, Inc. Service Representative.**

In the event of a fire alarm, certain equipment may be required to be shut down. For example, shut down may be achieved by interrupting the fan supply source to that particular piece of equipment when wired as indicated in Figure 6.

### Installation Of PE-11 Smoke Detectors

To Install:

- Remove cover by loosening the four screws. Take off the cover and set it aside.
- Align detector with base and insert detector.
- Rotate detector clockwise while gently pressing on it until the detector drops fully into base.
- Then rotate the detector clockwise until it stops and snaps in place.
- Replace cover and tighten the four screws.

To Remove:

- Rotate the detector counterclockwise until stop is reached.
- Pull detector out of base.

TESTING	Only qualified service personnel should test these units. To assure proper operation of the detector and control panel, both the Sensitivity and the Functional tests should be conducted. The minimum test schedule may be found in the current edition of NFPA 72 for installations in the U.S
Sensitivity Test	The PE-11 detector monitors its smoke sensitivity automatically and requires no test equipment. A green flash of the detector LED about every seven seconds indicates that the smoke sensitivity is within its listed limits.
Functional Test	Smoke Testing Using TG-11 smoke test canister with testing nozzle model AD-TGN (purchased separately) available from Siemens Industry, Inc., insert the test gas nozzle into the hole in the red plug in the unit cover. Press can against cover for about 1/2 second to release gas into the chamber.

### Detector LED

The AD2-4W contains an LED indicator (located on the PE-11 smoke detector) capable of flashing either one of three distinct colors: green, yellow, or red. During each flash interval, the microprocessor based detector checks the following:

- for smoke in its sensing chamber
- that its critical smoke sensing electronics are operating.

Based on the results of these checks, the LED indicator flashes as follows:

Flash Color	Condition	PE-11 Flash Interval (Seconds)
Green	Normal supervisory operation.	7
Yellow	Detector requires service (cleaning or repair) or is operating beyond its environmental specifications.	7-30
Red	Alarm	2½
No Flashes	Detector is not powered, or requires repair.	-

### MOUNTING THE AIR DUCT HOUSING

#### Location on Duct System

This guideline contains general information on duct smoke detector installation, but does not preclude the NFPA documents listed. Siemens Industry, Inc. assumes no responsibility for improperly installed duct detectors. To determine the correct installation position for an AD2-4W duct smoke detector, the following factors must be considered.

- 1) A uniform non-turbulent (laminar) airflow between 100 ft/min. to 4,000 ft/min. must be present in the HVAC duct. To determine duct velocities, examine the engineering specifications that define the expected velocities or use an Anlor model 6000AP velocity meter (or equivalent).
- 2) To minimize the impact of air turbulence and stratification on performance, a duct smoke detector should be located as far as possible downstream from any obstruction (i.e. deflector plates, elbows, dampers, etc.). In all situations, confirmation of velocity and pressure differential within specifications is required.

The pressure differential between the input sampling (high pressure) tube and outlet (low pressure) tube for the AD2-4W smoke duct detector should be greater than 0.01 inches of water and less than 1.2 inches of water.

- 3) Identify a code compliant location (supply or return side, or both) for the installation of the duct unit that will permit easy access for viewing and serviceability.
- 4) When installing on the return side, install duct units prior to the air being exhausted from the building or diluted with outside "fresh" air.
- 5) When installing duct smoke units downstream of filters, fires occurring in the filters will be detected, but if the filters become blocked, insufficient air flow through the duct unit will prevent the correct operation of the duct detector. Duct units installed in the supply air side may monitor upstream equipment and/or filters.

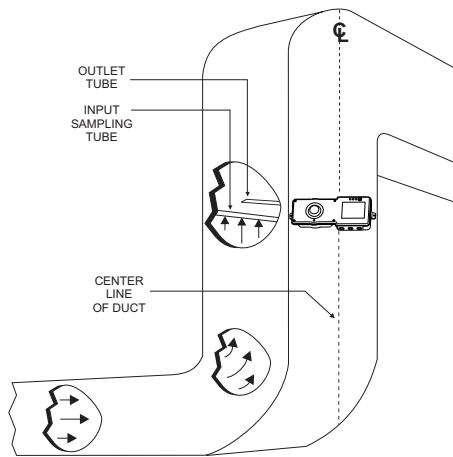

Figure 1  
Typical Mounting of Duct Housing

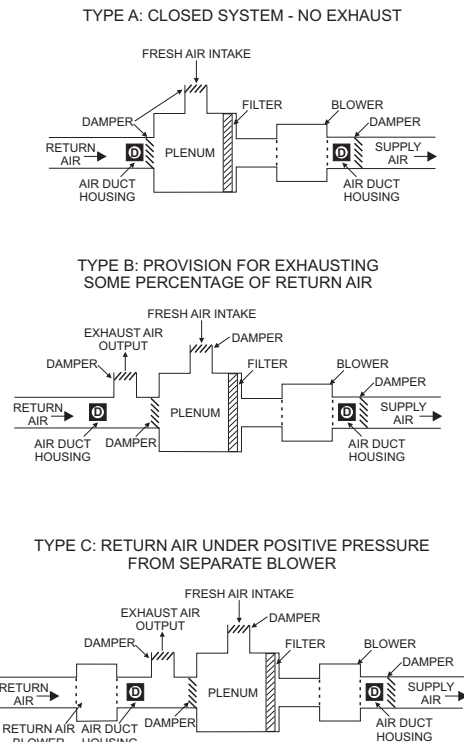

Figure 2  
Recommended Locations in Duct Systems

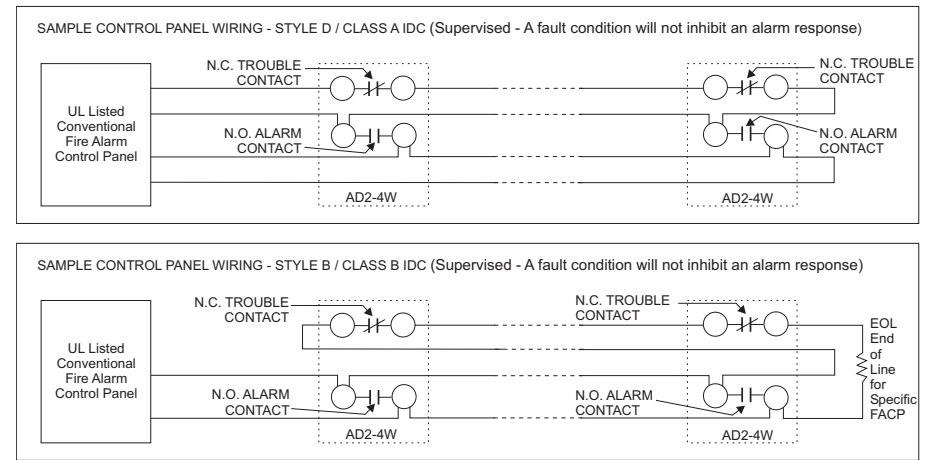

Figure 7  
Wiring the AD2-4W to a Fire Alarm Control Panel

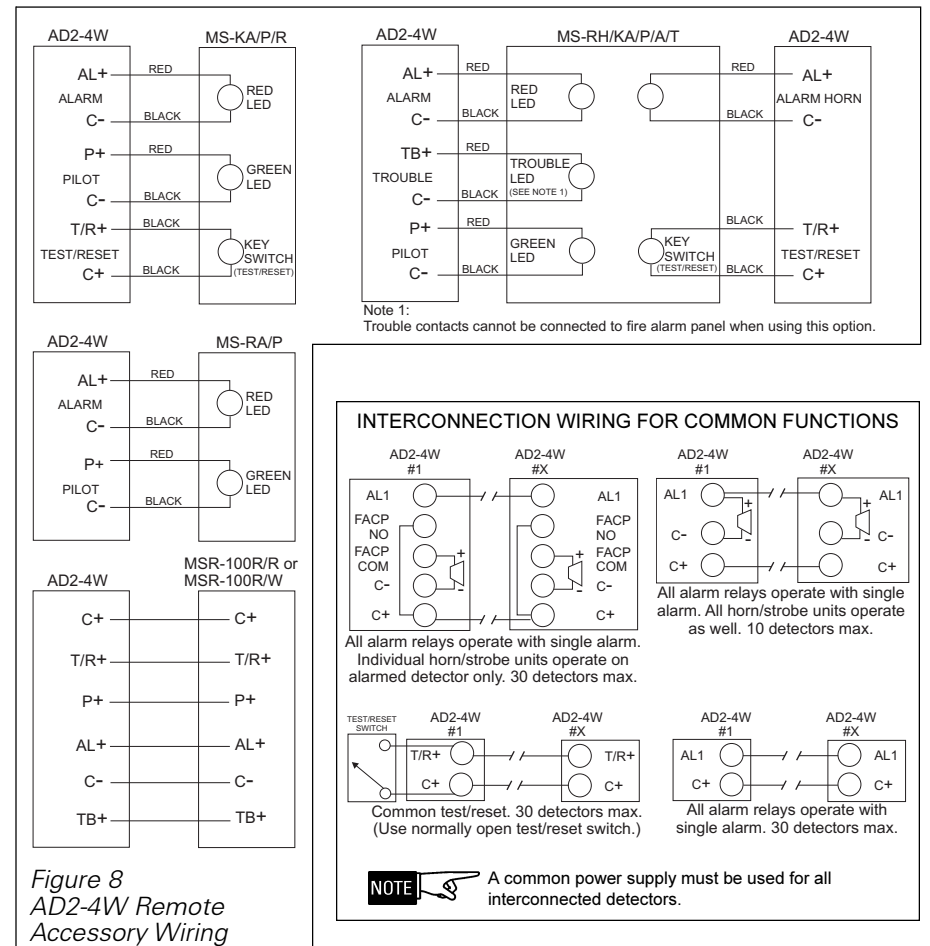
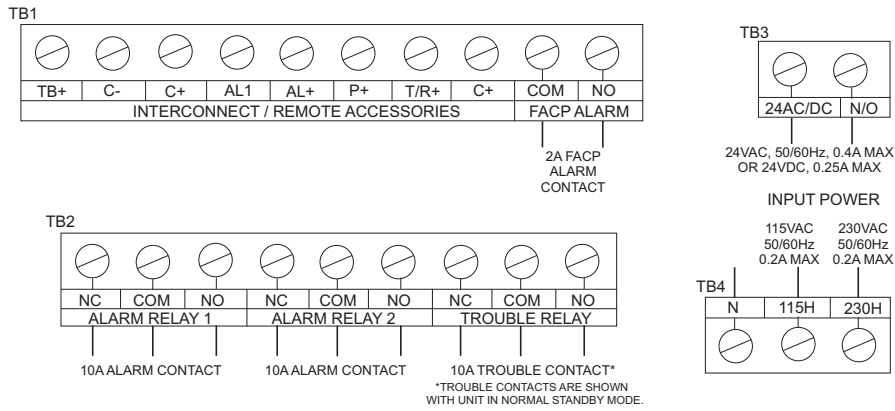

Figure 8  
AD2-4W Remote Accessory Wiring



AD2-4W WIRING			
TERMINAL	SILK SCREEN MARKING	CONNECTION	
TB1	INTERCONNECT / REMOTE ACCESSORIES	TB+	Low current trouble output for remotes - +24VDC when unit detects trouble
		C-	Ground
		C+	24VDC output
		AL1	High current alarm output - +24VDC when smoke detected
		AL+	Low current alarm output for remotes - +24VDC when smoke detected
		P+	Power out to remotes - Cut when head or cover removed
		T/R+	Test/Reset input - Apply 24VDC to test or reset
	C+	24VDC output	
	FACP	COM	Fire Alarm Control Panel Relay - COM contact
		NO	Fire Alarm Control Panel Relay - NO contact - Open in normal standby mode
TB2	ALARM RELAY 1	NC	Alarm 1 relay - NC contact - Opened when smoke detected
		COM	Alarm 1 relay - COM contact
		NO	Alarm 1 relay - NO contact - Closed when smoke detected
	ALARM RELAY 2	NC	Alarm 2 relay - NC contact - Opened when smoke detected
		COM	Alarm 2 relay - COM contact
		NO	Alarm 2 relay - NO contact - Closed when smoke detected
	TROUBLE	NC	Trouble relay - NC contact - Closed in normal standby mode
		COM	Trouble relay - COM contact
		NO	Trouble relay - NO contact - Open in normal standby mode
TB3	INPUT POWER	24AC/DC	Power input - 24VAC Hot or 24VDC positive
		N/O	Power input - 24VAC Neutral or 24VDC negative
TB4	INPUT POWER	N	Power input - AC Neutral
		115H	Power input - 115VAC Hot
		230H	Power input - 230VAC Hot

Figure 5  
Wiring the AD2-4W

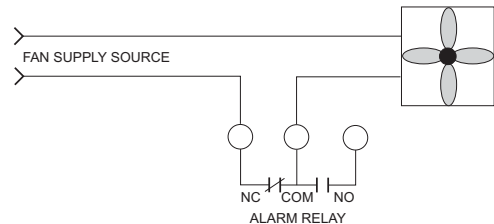

Figure 6  
Stand Alone Wiring the AD2-4W

- Where possible, install duct detectors upstream of air humidifiers and downstream of dehumidifiers.
- To prevent false alarms, the duct detector should not be mounted in areas of extreme high or low temperatures, in areas where high humidity exists, or in areas where the duct may contain gases or excessive dust.

### Duct Preparation

The AD2-4W Housings come with an installation kit that contains the following items:

- Short return (outlet) tube
- Input sampling tube stopper
- Two #12 x 3/4" sheet metal screws
- Mounting template (packaged separately)

Remove mounting template. Remove paper backing from the mounting template and affix it to the duct at the desired location. Using the template as a guide, drill (2) mounting holes, 3/32" (2.5mm) for the #12 X 3/4" sheet metal screws packaged in the installation kit. Drill or punch (2) 1 1/4" (32mm) holes for input sampling and outlet tubes, using the template as a guide. Clean all holes.

### Sampling Tube Installation

The AD2-4W duct smoke detectors use a specially notched sampling tube, which may be ordered separately in one of four standard lengths.

- ST-10 For duct widths of 6" to 1.0'
- ST-25 For duct widths of 1.0' to 3.0'
- ST-50 For duct widths of 3.0' to 5.0 (requires support)
- ST-100\* For duct widths of 5.0' to 10.0' (requires support)

\*This model is supplied as two 5 ft. sections with a coupling. Assembly is required for installation.



Each model is manufactured with a different number and size of sampling holes. Only the specific tube must be used for the specified duct width.

Standard sampling tubes are steel tubes with air intake holes drilled the entire length of the tube. These tubes can be cut to length and must span at least 80% the width of the duct. Sampling tubes over 3.0' must be supported on the opposite side of the duct. To ensure the correct operation, the red stopper (stopper in installation kit) must be inserted in the end of the air input sampling tube. If the input tube protrudes

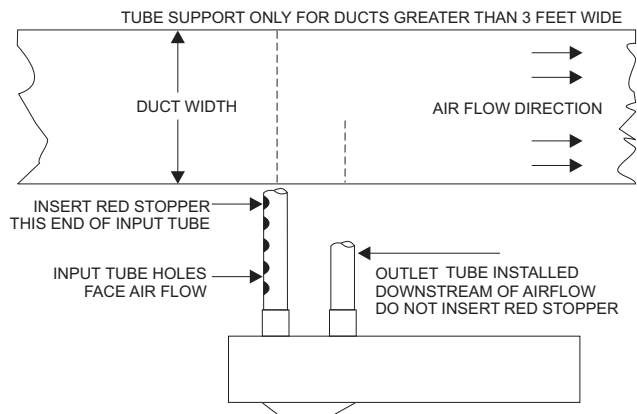

NOTE: Mountings shown are typical. Detectors can be installed side, bottom or top of duct as long as proper tube operation and flow/pressure performance is maintained.

Figure 3  
Sampling Tube Orientation

through the opposite side of the duct, the opening around the tube must be sealed. For custom duct widths, always use the next longest standard size and cut down to the exact requirement.

Once the airflow direction has been determined (refer to Figure 3), insert the input and outlet tubes into the duct housing.

1. Remove the cover from the housing.
2. Loosen the screw and rotate the tube retainer until the input tube is inserted and oriented properly. Ensure that the notched end of the tube is inside the housing and that the air input sampling tube is positioned so that the input holes are directly facing the airflow.
3. Once the tube is installed, rotate the retainer back into place and tighten screw.
4. Install the outlet tube in the remaining position. Once the tube is installed, rotate the retainer back into place and tighten screw.

#### Mounting

After securing the input and outlet tubes to the duct smoke unit, (or initially placing the tubes through the 1¼" holes drilled or punched in the HVAC duct to accept the input and outlet tubes and then attaching them to the duct unit), hold the duct unit assembly in position and use (2) # 12 X ¾" sheet metal screws (packaged in the installation kit) to secure the duct smoke detector to the HVAC duct sheet metal.

#### Air Duct Sampling Tube Pressure Measurement

The Model PDM-3 Pressure Differential Measuring device should be used to ensure that the sampling tube pressure differential is within the specified limits. The differential pressure between the two tubes should be greater than 0.01 inches of water and less than 1.2 inches of water. Qualified personnel should take measurements in accordance with the PDM-3 instructions, P/N 315-085535.

#### WIRING

##### Conduit Knockouts

To remove plastic knockout, first cut the plastic tab on the specific knockout. Refer to Figure 4 to locate the tab. Then, using a screw driver placed at the tab location, tap with a hammer until the knockout breaks out. Clean the hole before installing conduit.

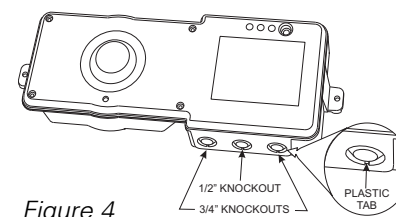

Figure 4  
Removing the Knockouts

#### Wiring



AD2-4W terminal wiring connections are shown in Figure 5. *Note any limitations on the number of detectors and restrictions on the use of remote devices permitted for each circuit.*

**Do not use looped wire under terminals. Break wire run to provide for proper supervision of connections.**

With detector head removed, connect one of the appropriate dedicated power sources to the applicable terminals (Refer to Figure 5). Replace detector head and depress the cover removal switch (SW1) on the PCB assembly and the unit will be energized. The green power LED will be illuminated, and when pressing the test/reset button (SW2) on the PCB assembly, the red alarm LED will be illuminated. This test confirms the correct basic operation of the duct smoke unit, excluding the detector head (see functional testing).

Wire the AD2-4W as a stand alone unit as shown in Figure 6. Wire the AD2-4W as part of a FACP as shown in Figure 7. Wire the AD2-4W accessories as shown in Figures 7 and 8.