



► Model 50GC

SelecTone® Amplified Speaker

Model 50GC SelecTone® Amplified Speaker is designed to produce crisp, clear tones, digital voice messages and live public address.

In Model 50GC a short, folded re-entrant horn is interposed between the diaphragm and surrounding air space. This design provides optimal dBA output and frequency response.

When installed with the WB Weatherproof Back Box, model 50GC is suitable for use outdoors.

SelecTone Amplified Speakers are used individually or as part of a plant-wide emergency notification system. Model UTM Universal Tone Module with 32 tones, or model TM33-SD Custom Tone Module is plugged into a single SelecTone Amplified Speaker for stand-alone use or into a SelecTone Command Unit for plant-wide signaling.

For plant-wide signaling, a Connector Kit is installed into each SelecTone Amplified Speaker and wired to a central controller. SelecTone Command Units and CommCenter® Digital Message Centers broadcast tones, voice messages, melodies and live public address to an unlimited number of SelecTone Amplified Speakers.

The compact size and attractive appearance of Model 50GC makes it ideal for use in offices, hallways, reception, and plant areas where ambient noise levels are not exceedingly high, and even sound dispersal is desired. Emergency signaling and paging are common applications.

FEATURES

- Available in 24VAC/DC and 120VAC
- Solid-state circuitry
- Built-in gain control, adjustable between 64 dBA to 88 dBA @ 10' (74 dBA to 98 dBA @ 1m)
- Flush or surface mount
- Type 3R enclosure when used with the WB back box
- CSFM Approved
- UL and cUL Listed

MODEL	VOLTAGE	OPERATING CURRENT	STANDBY CURRENT*	DECIBELS	
				10'	1M
50GC-024BG	24VDC	0.09 amps	0.037 amps	88	98
	24VAC 50/60Hz	0.29 amps	0.147 amps	88	98
50GC-120BG	120VAC 50/60Hz	0.04 amps	0.027 amps	88	98

*When used as a powered loud speaker

SelecTone® Amplified Speaker (50GC)

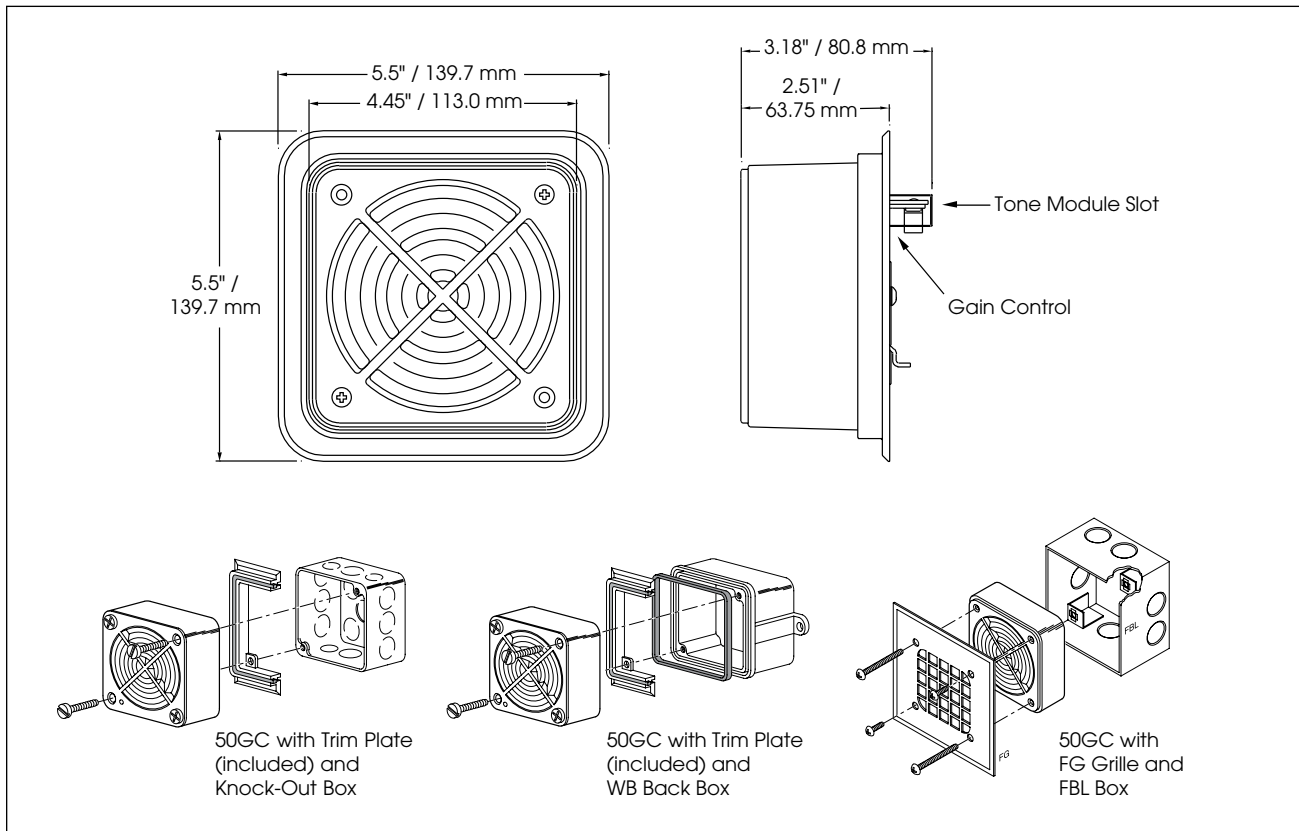

SPECIFICATIONS

Operating Temperature:	-31°F to 151°F	-35°C to 66°C
Net Weight:	1.7 lbs	0.8 kg
Shipping Weight:	2.2 lbs	1.0 kg
Height:	5.5"	139.7 mm
Width:	5.5"	139.7 mm
Depth:	3.18"	80.8 mm

OPTIONAL ACCESSORIES

Description	Part Number
Weatherproof Back Box	WB
Grille	FG
Flush Mount Back Box	FBL

HOW TO ORDER

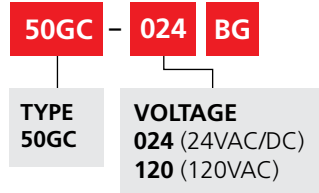

1. Select Model

2. Select Required Accessory (sold separately)

- A. For stand alone operation, select Tone Module:
 - UTM** – Universal Tone Module (Reference page 215 for list of tones)
 - TM33-SD** – Custom Tone Module (Reference page 217 for list of tones)
- B. For use in systems*, select Connector Kit. (Reference page 218 for Connector Kits)
 - AM25CK** – 25 Vrms, 1 Vrms
 - AM70CK** – 70 Vrms, 1 Vrms
 - 300CK** – 10 Vrms, 1 Vrms
 - T-300CK** – 2.7 Vrms, 1 Vrms
 - E-300CK** – 1 Vrms, 1 Vrms

*Call factory for design assistance