

FIRE

## Fiber Optic Modem Installation Instructions



579-831  
Rev. F



## Copyright and Trademarks

---

**Copyright**

©2006-2011 SimplexGrinnell LP. All rights reserved.

Specifications and other information shown were current as of publication and are subject to change without notice.

---

**Trademarks**

Simplex® and the Simplex logo are trademarks of Tyco International Ltd. and its affiliates and are used under license.

All other logos and product names are trademarks or registered trademarks of their respective companies.

---

## Cautions and Warnings

---

**READ AND SAVE THESE INSTRUCTIONS.** Follow the instructions in this installation manual. These instructions must be followed to avoid damage to this product and associated equipment. Product operation and reliability depends upon proper installation.



**DO NOT INSTALL ANY SIMPLEX® PRODUCT THAT APPEARS DAMAGED.** Upon unpacking your Simplex product, inspect the contents of the carton for shipping damage. If damage is apparent, immediately file a claim with the carrier and notify your Simplex product supplier.



**ELECTRICAL HAZARD** - Disconnect electrical field power when making any internal adjustments or repairs. All repairs should be performed by a representative or authorized agent of your local Simplex product supplier.



**STATIC HAZARD** - Static electricity can damage components. Therefore, handle as follows:

- Ground yourself before opening or installing components.
- Prior to installation, keep components wrapped in anti-static material at all times.



**EYE SAFETY HAZARD** - Under certain fiber optic application conditions, the optical output of this device may exceed eye safety limits. Do not use magnification (such as a microscope or other focusing equipment) when viewing the output of this device.

**FCC RULES AND REGULATIONS – PART 15** - This equipment has been tested and found to comply with the limits for a Class A digital device, pursuant to part 15 of the FCC Rules. These limits are designed to provide reasonable protection against harmful interference when the equipment is operated in a commercial environment. This equipment generates, uses, and can radiate radio frequency energy and, if not installed and used in accordance with the instruction manual, may cause harmful interference to radio communications. Operation of this equipment in a residential area is likely to cause harmful interference in which case the user will be required to correct the interference at his own expense.

**SYSTEM REACCEPTANCE TEST AFTER SOFTWARE CHANGES** - To ensure proper system operation, this product must be tested in accordance with NFPA 72® after any programming operation or change in site-specific software. Reacceptance testing is required after any change, addition or deletion of system components, or after any modification, repair or adjustment to system hardware or wiring.

All components, circuits, system operations, or software functions, known to be affected by a change, must be 100% tested. In addition, to ensure that other operations are not inadvertently affected, at least 10% of initiating devices that are not directly affected by the change, up to a maximum of 50 devices, must also be tested and proper system operation verified.

NFPA 72® is a registered trademark of the National Fire Protection Association.

---

# Contents

Introduction to the Fiber Optic Modem .....	1
General Overview .....	1
Definitions and Terms.....	1
Digital Audio Riser Overview .....	2
Analog Audio Riser Overview.....	2
4120 Network Overview .....	2
RUI Overview.....	2
Fiber Modem Audio Expansion Board .....	2
Illustration.....	3
PID List.....	4
Specifications.....	4
Modem Configuration.....	6
Supported Configurations .....	6
SW1 (RUI/4120 Network) Configuration Settings .....	6
SW2 (Digital Audio Riser, Enhanced Analog Audio, and Standard Analog Audio Channel 1) Configuration Settings .....	7
SW3 (Analog Audio Channel 2) Configuration Settings.....	8
SW4 (Fiber Modem Audio Expansion Board) Configuration Settings.....	8
4120 Network Wiring, Analog Audio, and RUI Jumper Placements .....	9
Fiber Modem Audio Expansion Board .....	10
Description.....	10
Jumper Configuration .....	10
Mounting.....	11
Mounting Instructions .....	11
Wiring.....	14
Overview.....	14
Fiber Connection.....	14
4120 Network Wiring Specifications.....	15
Analog Audio Riser Wiring Specifications.....	17
Enhanced Analog Audio (EAA) Riser Wiring Specifications .....	19
Digital Audio Riser Specifications.....	21
RUI Wiring Specifications.....	22
Fiber Modem Audio Expansion Board Wiring Specifications.....	24
Connecting Power to the Modem.....	25
Where to Connect Power .....	25
Testing and Troubleshooting .....	27
General.....	27
LED Indications .....	28
Fiber Fault LED .....	28
Digital Audio Riser (DAR).....	28
Analog Audio.....	29
4120 Network .....	29
RUI .....	29
System Checkout .....	29
Testing Circuit Supervision .....	30
Appendix – Sample Configurations.....	31
Overview.....	31
Internal Building or Multi-Building Configuration – Class A/Style 7 or Style 6.....	31
RUI (excluding 4120 Network) Class A/Style 7.....	32
4120 Network (excluding RUI) Class A/Style 7.....	33
Analog Audio Class A/Style 6.....	34
Enhanced Analog Audio (EAA) (limited to Channel 1 & excluding Digital Audio) Class A/Style 6 .....	35
Digital Audio (excluding Analog Audio Channel 1) Class A/Style 7.....	36
Internal Building or Multi-Building Configuration – Class B/Style 4.....	37
RUI (Excluding 4120 Network) Class B/Style 4 .....	38

Analog Audio Class B/Style 4 .....	39
Enhanced Analog Audio (EAA) (limited to Channel 1 & excluding Digital Audio) Class B/Style 4.....	40
Digital Audio (excluding Analog Audio Channel 1) Class B/Style 4.....	41
Hub Configuration Overview.....	42
Hub Configuration – 4120 Network .....	43
Hub Configuration – Analog Audio.....	44
Hub Configuration – Digital Audio .....	45
Interconnected Loop and Star Configurations – Overview .....	46
Interconnected Loop and Star Configurations –4120 Network.....	47
Interconnected Loop and Star Configurations – Analog Audio .....	48
Interconnected Loop and Star Configurations – Digital Audio.....	49
TrueSite Workstation (TSW) .....	50
Fiber Modem Audio Expansion Board Class A/Style 6.....	51
Fiber Modem Audio Expansion Board Class B/Style 4.....	52

---

# Introduction to the Fiber Optic Modem

---

## General Overview

The Fiber Optic Modem is used to simplify field wiring and increase transmission distances by converting system copper-wired interfaces to fiber optic connections. It has field wiring connections for the Digital Audio Riser, Analog Audio Risers, RUI, and 4120 Network. A Modem pair replaces copper wiring between any two points including node-to-node, node-to-transponder, and transponder-to-transponder. The Modem is invisible to the connected equipment, and does not need to be programmed in as part of the job (except for power supply current calculations). The Modem combines the input signals so they can be communicated over one fiber in both directions.

In general, the Modem installation is accomplished by simply connecting the wires that would normally be routed between cabinets to the Modem. The only additional steps required when using a Modem rather than copper are:

- 1) Configuring the DIP switches and jumpers according to the application.
- 2) Routing the “x-link” wire *if* the system has Class A Analog Audio or Class A RUI.

Modems are always installed in pairs. There are four versions: a “right-port” and “left-port” version for each type of fiber; left and right for single-mode and a left and right for multimode. Any Modem link must consist of one of each type. The order in which Modem pairs are installed is arbitrary. A “left-to-right” Modem pair can be followed by another “left-to-right” pair, or by a “right-to-left” pair.

---

## Definitions and Terms

**Enhanced Analog Audio (EAA):** EAA refers to a reformatted version of the Analog Audio Riser that is wired between modems. In an EAA system, modems pass the Riser to the next modem as a digital signal via the DAR channel. EAA disallows the use of Analog Channel 2.

**Generic:** A “Generic” modem is any modem that is not a Head-End or Tail-End modem. In a Class B configuration, all modems are generic.

**Head end:** A “Head-End” modem is a modem with an electrical connection to the primary side of the head-end cabinet. If there are any fiber optic links between a modem and the head-end cabinet, then that modem is not a head-end modem. A modem with additional nodes or transponders between itself and the head-end cabinet, but no optical links, can still be a head-end modem.

**Local side:** The “local side” of any configuration refers to all portions of the wiring loop that are electrically connected to the head-end cabinet. Any wiring that is isolated from the head end via one or more optical links is not electrically connected, and therefore considered “remote.”

**NIC:** Network Interface Card.

**Remote side:** The “remote side” of any configuration refers to all portions of the wiring loop that are not electrically connected to the head-end cabinet. Any system that is electrically connected to the head end (no optical links) is considered “local.”

**RIC:** Riser Interface Card.

**Tail end:** A “Tail-End” modem is a modem with an electrical connection to the secondary side (also known as a Class A return) of the head-end cabinet. If there are any fiber optic links between a modem and the head-end cabinet, then that modem is not considered a tail-end modem. A modem with additional nodes or transponders between itself and the head end, but no optical links, can still be a tail-end modem.

**X-link:** The “x-link” is a pair of RUI or Analog Audio Riser wires that connect head-end and tail-end modems to one another. The link is required to maintain an electrical connection between the primary and secondary sides of the local-side wiring loop. (**X-link definition is continued on the next page.**)

---

*Continued on next page*

# Introduction to the Fiber Optic Modem, *Continued*

---

## Definitions and Terms

**X-link (continued):** X-link connections are **only** required in Class A Analog Audio and Class A RUI configurations. They **are not required** for the Digital Audio Riser interface, a Network interface, or for any other Class B configuration. Where required, the x-link connection maintains Class A supervision even though the remote side of the fiber link is electrically isolated. The x-link is only wired between the two modems that are electrically connected to the head-end cabinet via RUI or riser wiring. (It is still considered electrically connected even if there are transponders between the modem and the head-end cabinet).

---

## Digital Audio Riser Overview

The Modem replaces copper wiring between a Digital Audio Controller and a Digital Audio Riser Interface Card, or between Digital Audio Riser Interface cards. Modem connections can be used between transponders, or between nodes in Network systems.

---

## Analog Audio Riser Overview

The Modem replaces copper wiring between an Analog Audio Controller and an Analog Audio Riser Interface Card, or between Analog Audio Riser Interface cards. Modem connections can be used between transponders, or between nodes in network systems. The Modem can be configured for 10 Vrms audio risers (standard), 1 V peak-to-peak audio risers, or 0.707 Vrms.

The standard analog audio usage of the fiber modem imposes a 6-modem-pair limit on system size. The Enhanced Analog Audio (EAA) feature removes this limitation by keeping a version of the analog stream digital through the wired link. Using EAA imposes other limitations, however, that include the following:

- Limitation to one analog channel only (Channel 1).
  - Requires that the EAA wire (connected to DAR terminals) be close nipped (since it is unsupervised).
  - Excludes the usage of the DAR interface for the Digital Audio Riser because the DAR interface is used as the EAA channel.
- 

## 4120 Network Overview

The Modem can replace either one or two wired connections between Network Interface Cards. It can replace the right-port wire, the left-port wire, or both. The Network Interface Cards that the Modem will connect to must have wired media cards installed. The Modem can be used to replace wiring between any two NICs, and it can also be used in lieu of a Physical Bridge. When the Modem is used in lieu of a Physical Bridge, the network topology appears as a typical ring configuration since the Modem effectively replaces two wires between the local and remote node.

Refer to Figure A-18 that shows an Interconnected Loop without a Physical Bridge. The Interconnected Loop normally requires a Physical Bridge but doesn't in this diagram because modems are used.

Note that references to 4020, 4120, and 4100 Legacy Fire Alarm Panel systems are for retrofit applications only. None of these Fire Alarm System models have been listed to the Ninth Edition of UL864.

---

## RUI Overview

The Modem replaces copper wiring between a CPU Motherboard and Transponder Interface card, between Transponder Interface cards, or between a RUI card and Transponder Interface card. Maximum of eight pairs of Modems for RUI if wired Class A.

---

## Fiber Modem Audio Expansion Board

The Audio Expansion Board allows the Fiber Optic Modem to interface with 4100 Legacy Audio systems. The card has two channels, each of which are selectable for 70 Vrms or 25 Vrms risers. The card converts the 70 Vrms or 25 Vrms to a 10 Vrms signal to be used by the modem. The card connects to the modem via a ribbon harness.

---



# Introduction to the Fiber Optic Modem, *Continued*

**Illustration**

See Figure 1 (below) for important locations on the Modem board.

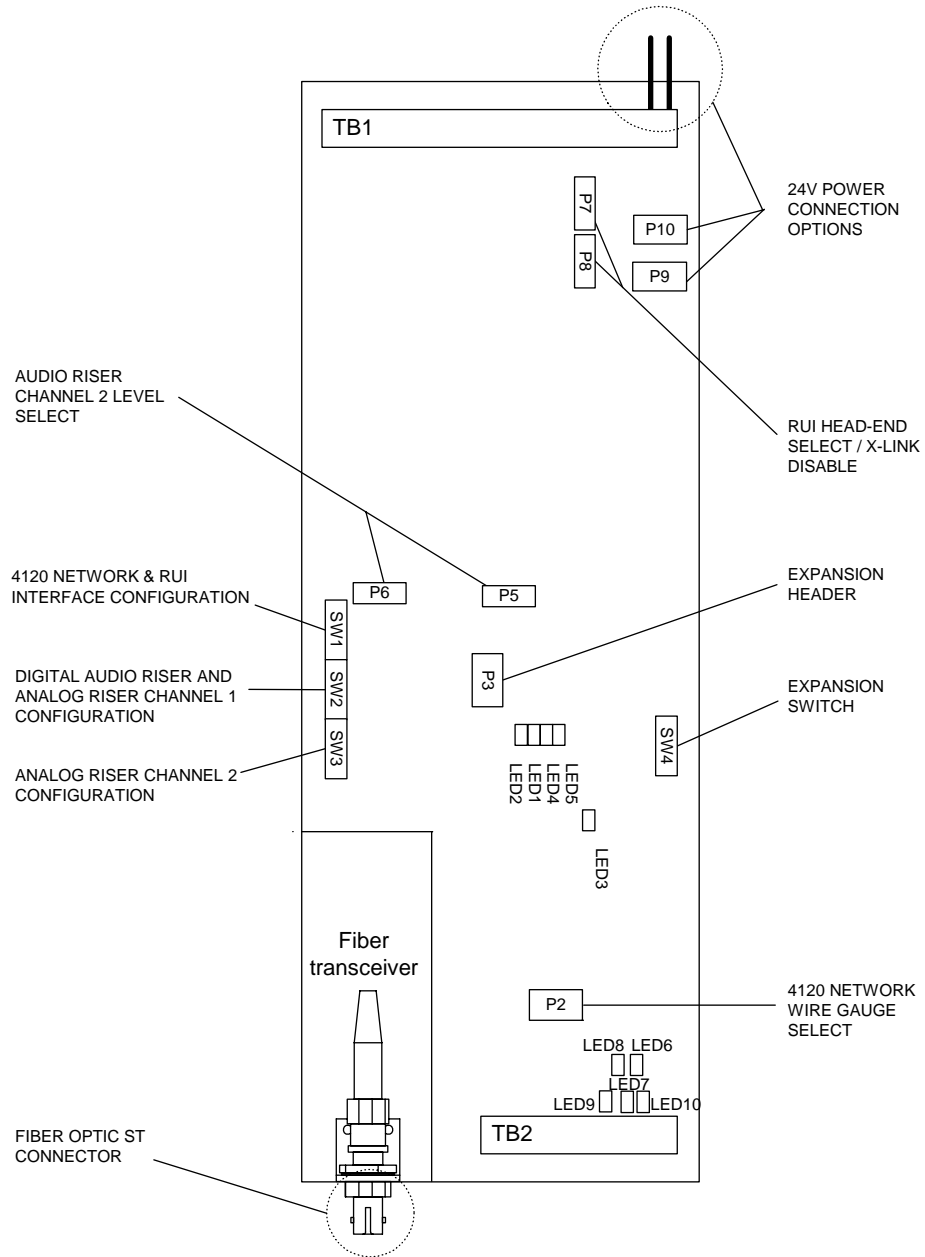

**Figure 1. Fiber Optic Modem Board**

## Introduction to the Fiber Optic Modem, *Continued*

### PID List

This publication covers the following Product IDs (PIDs):

**Table 1. Product IDs Covered by this Publication**

<b>Multimode Fiber Part Numbers</b>		
<b>PID</b>	<b>Description</b>	<b>Usage</b>
4100-6074	Fiber Optic Modem Left-Port Assembly	4100U/4100ES Bay Installation
4100-6075	Fiber Optic Modem Right-Port Assembly	4100U/4100ES Bay Installation
4190-9024	Fiber Optic Modem with Expansion Cabinet Assembly - Red	Expansion to 4100ES, 4100U, 4100, 4010, or 4020
4190-9025	Fiber Optic Modem with Expansion Cabinet Assembly - Beige	Expansion to 4100ES, 4100U, 4100, 4010, or 4020
4190-9026	Fiber Optic Modem Right-Port Assembly (For Expansion Cabinet Only)	Expansion Cabinet Installation
<b>Single-mode Fiber Part Numbers</b>		
<b>PID</b>	<b>Description</b>	<b>Usage</b>
4100-6072	Fiber Optic Modem Left-Port Assembly	4100U/4100ES Bay Installation
4100-6073	Fiber Optic Modem Right-Port Assembly	4100U/4100ES Bay Installation
4190-9021	Fiber Optic Modem with Expansion Cabinet Assembly - Red	Expansion to 4100ES, 4100U, 4100, 4010, or 4020
4190-9022	Fiber Optic Modem with Expansion Cabinet Assembly - Beige	Expansion to 4100ES, 4100U, 4100, 4010, or 4020
4190-9023	Fiber Optic Modem Right-Port Assembly (For Expansion Cabinet Only)	Expansion Cabinet Installation
<b>Other Part Numbers</b>		
<b>PID</b>	<b>Description</b>	<b>Usage</b>
4100-9840	Remote Box Modem Mounting Bracket	4100 Cabinet or Generic Expansion Cabinet
4100-9841	Fiber Modem Audio Expansion Board with 4100 Mounting Bracket	4100 Bay Installation
4100-9842	Fiber Modem Audio Expansion Board	4100 Installation (Mounts on Bracket Shipped with 4100-9841)
4190-9018	Fiber Modem Audio Expansion Board (For Expansion Cabinet Only)	Expansion Cabinet Installation

### Specifications

The two versions of each type of Modem assembly (“left” and “right”-port versions) both transmit and receive simultaneously on two different wavelengths over a single fiber. Fiber connects to the Modem using standard ST-type connectors.

*Continued on next page*

# Introduction to the Fiber Optic Modem, *Continued*

Table 2 lists specifications for the Fiber Optic Modems and the Audio Expansion Board.

**Table 2. Fiber Optic Modem Specifications**

<b>Current/Voltage Requirements</b>	
Card Current @ 24 VDC	Analog Channels in Use (Standby or Alarm): 360 mA Analog Channels Disabled (Standby or Alarm): 190 mA Fiber Modem Audio Expansion Board (Standby or Alarm): 20 mA
Card Voltage	18-33 VDC
<b>Optical Specifications</b>	
Transmitting and Receiving	Left-Port: 1310 nm transmit; 1550 nm receive Right-Port: 1550 nm transmit; 1310 nm receive
Link Distances	<p>Single-Mode Fiber: Maximum total attenuation: 15 dB                      Example 1: fiber attenuation of 0.34 dB/km over 35,000 feet (10.7 km) = 3.6 dB, connectors totaling 6 dB, safety margin remaining of 5 dB                      Example 2: fiber attenuation of 0.6 dB/km over 25,000 feet (7.7 km) = 4.6 dB, connectors totaling 5 dB, safety margin remaining of 5 dB                      Connectors: No limit specified</p> <p>Multi-Mode Fiber: 5,000 feet (1.6 km) maximum (50 um or 62.5 um GRIN).                      Maximum total attenuation: 6 dB                      Connectors: Three or less (in addition to the connections to the modems)</p> <p><b>NOTE:</b> Single-mode fiber is preferred. Attenuation should be measured at 1310 nm.</p>
<b>Environmental Specifications</b>	
Operating Temperature	32° to 120° F (0° to 49° C)
Humidity	Up to 93% relative humidity at 90° F (32° C), non-condensing

An initial acceptance test of each fiber link shall be performed as stated in NFPA 72. A fiber link is defined as all fiber segments, including patch cords, which create a fiber path from one modem to another. The fiber lines shall be tested using an OTDR. The OTDR will measure the attenuation of the fiber as well as indicate the presence and location of connectors and any defects in the link. The fiber infrastructure shall be accepted for use only after it has been determined that it meets or exceeds industry standards (TIA/EIA 568).

# Modem Configuration

## Supported Configurations

The allowed application configurations for the Modem are as follows:  
 Configuration #1 – Digital Audio Riser, Analog Riser #2, and Network.  
 Configuration #2 – Digital Audio Riser, Analog Riser #2, and RUI.  
 Configuration #3 – Both Analog Risers and Network.  
 Configuration #4 – Both Analog Risers and RUI.

The configurations listed are the fully-loaded configurations only. In addition to these configurations, any combination can be reduced as required. For example, the Digital Audio Riser can be used in conjunction with RUI only, or all by itself, or the 4120 Network can be used by itself, etc. Each component of these configurations is completely independent of one another.

Each of the wired interfaces to the Modem is configured independently of one another. Refer to the “Sample configurations” section (in the Appendix at the rear of this publication) for diagrams of some sample configurations, and additional information on configuring the Modem.

## SW1 (RUI/4120 Network) Configuration Settings

SW1 selects between the 4120 Network and RUI, and configures each interface according to how the modem will be used. If you are not using either of these interfaces, then set SW1 to 4120 Network (position 5 OFF). See Table 3 for settings and Figure 1 for the switch location on the modem board.

**Table 3. SW1 Switch Settings**

Position	Description	ON	OFF	Interface
*1	RUI media wiring type	Class A	Class B	RUI
*2	RUI media default mode	TIC	RUI	
*3	RUI media generic select	Not Generic	Generic	
*4	RUI media location select	Tail End	Head End	
*5	Comm media selection	RUI enable	4120 Network enable	4120
†6	4120 Network protocol	8-Bit	9-Bit	
†7	4120 Network baud rate	9600 Baud	57.6K	
8	4120 Network	Invalid	4120 Network	

### RUI Notes

- \*1 Set this switch to ON if the Modem is part of a Class A RUI loop. Set this switch to OFF if the Modem is wired Class B.
- \*2 Set this switch to ON if the Modem is on the primary side of a Modem pair. Set this switch to OFF if the Modem is on the secondary side of a Modem pair. If the Modem is a Head-End or Tail-End Modem, then always set the switch to ON.
- \*3 Set to ON if the Modem is a Head-End or Tail-End Modem. Set to OFF if the Modem is on the remote side of a wiring loop (isolated from the CPU motherboard or RUI card via an optical link or Modem pair (fiber).
- \*4 Set to ON if the Modem is connected to the secondary of the 4100U/4100ES motherboard (or RUI card) because it's then considered a Tail-End Modem. If there are additional transponders between the Modem and the secondary of 4100U/4100ES motherboard (or RUI card), but no additional fiber links, then it's still a Tail-End Modem and should have the switch set to ON. Set the switch to OFF if the Modem is connected to the primary of the 4100U/4100ES motherboard (or RUI card) because it's then considered a Head-End Modem. If there are additional transponders between the Modem and the primary of the 4100U/4100ES motherboard (or RUI card), but no additional fiber links, then it's still a Head-End Modem and should have the switch set to OFF. If the Modem is neither a Head-End nor a Tail-End Modem, then it is a “generic” Modem for which the switch setting does not matter.

### Comm Media Selection Notes

- \*5 Set to OFF if the 4120 Network interface is being used, ON if the RUI interface is being used, and OFF if neither RUI nor 4120 network interface is being used.

### 4120 Network Notes

- †6 Set 4120 Network protocol (8 or 9 bits) to match all connected Network Interface Cards.
- †7 Set 4120 Network baud rate (9600 or 57.6 K) to match all connected Network Interface Cards.

## Modem Configuration, *Continued*

### SW2 (Digital Audio Riser, Enhanced Analog Audio, and Standard Analog Audio Channel 1) Configuration Settings

SW2 controls the Digital Audio Riser (DAR) enable status, controls Enhanced Analog Audio, and configures Channel 1 for the Standard Analog Audio Riser. See Table 4 for settings and Figure 1 for the switch location on the modem board.

**Table 4. SW2 Switch Settings**

Position	Description	ON	OFF	Interface
*1	Analog Riser Channel 1 wiring	Class A	Class B	<b>Standard Analog</b>
*2	Analog Riser Channel 1 default mode	Riser Interface	Audio Controller	
*3	Analog Riser Channel 1 generic select	Not Generic	Generic	
*4	Analog Riser Channel 1 location select	Tail End	Head End	
*5	Analog Riser Channel 1 enable	Enable	Disable	
†6	Enhanced Analog Audio wired	Wired	Not Wired	<b>Enhanced Analog</b>
†7	Enhanced Analog Audio enable	Enable	Disable	
†8	DAR enable	Enable	Disable	<b>Digital</b>

#### Standard Analog Audio Notes

- \*1 Set this switch to ON if the Modem is part of a Class A Riser loop. Set this switch to OFF if the Modem is wired Class B
- \*2 Set this switch to ON if the Modem is on the primary side of a Modem pair. Set this switch to OFF if the Modem is on the secondary side of a Modem pair. If the Modem is a Head-End or Tail-End Modem, then always set the switch to ON
- \*3 Set this switch to ON if the Modem is a Head-End or Tail-End Modem. Set to OFF if the Modem is isolated from the Audio Controller card via an optical link or Modem pair (fiber).
- \*4 Set this switch to ON if the Modem is connected to the secondary of the Audio Controller because it's then considered a Tail-End Modem. If there are additional transponders between the Modem and the secondary of the Audio Controller, but no additional fiber links, then it's still a Tail-End Modem and should have the switch set to ON. Set to OFF if the Modem is connected to the primary of the Audio Controller because it's then considered a Head-End" Modem. If there are additional transponders between the Modem and the primary of the Audio Controller, but no additional fiber links, then it's still a Head-End Modem and should have the switch set to OFF. If the Modem is neither a Head-End nor a Tail-End Modem, then it is a "generic" Modem for which the switch setting does not matter.
- \*5 Set this switch to ON if that riser channel interface is to be used.

#### Enhanced Analog Audio Notes

- †6 Set this switch to ON if the modem is passing the EAA over the DAR channel in an EAA system. Set this switch to OFF for all other conditions.
- †7 Set this switch to ON if EAA is to be used.

#### Digital Audio Notes

- †8 Set this switch to ON if the Digital Audio Riser interface is to be used.

## Modem Configuration, *Continued*

### SW3 (Analog Audio Channel 2) Configuration Settings

SW3 configures Channel 2 of the Analog Audio Riser. See Table 5 for settings and Figure 1 for the switch location on the modem board.

**Table 5. SW3 Switch Settings**

Position	Description	ON	OFF	Interface
*1	Analog Riser Channel 2 wiring	Class A	Class B	<b>Standard Analog</b>
*2	Analog Riser Channel 2 default mode	Riser Interface	Audio Controller	
*3	Analog Riser Channel 2 generic select	Not Generic	Generic	
*4	Analog Riser Channel 2 location select	Tail End	Head End	
*5	Analog Riser Channel 2 enable	Enable	Disable	
6	Spare	-	-	
7	Spare	-	-	
8	Spare	-	-	

#### Standard Analog Audio Notes

- \*1 Set this switch to ON if the Modem is part of a Class A Riser loop. Set this switch to OFF if the Modem is wired Class B
- \*2 Set this switch to ON if the Modem is on the primary side of a Modem pair. Set this switch to OFF if the Modem is on the secondary side of a Modem pair. If the Modem is a Head-End or Tail-End Modem, then always set the switch to ON
- \*3 Set this switch to ON if the Modem is a Head-End or Tail-End Modem. Set to OFF if the Modem is isolated from the Audio Controller card via an optical link or Modem pair (fiber).
- \*4 Set this switch to ON if the Modem is connected to the secondary of the Audio Controller because it's then considered a Tail-End Modem. If there are additional transponders between the Modem and the secondary of the Audio Controller, but no additional fiber links, then it's still a Tail-End Modem and should have the switch set to ON. Set to OFF if the Modem is connected to the primary of the Audio Controller because it's then considered a Head-End Modem. If there are additional transponders between the Modem and the primary of the Audio Controller, but no additional fiber links, then it's still a Head-End Modem and should have the switch set to OFF. If the Modem is neither a Head-End nor a Tail-End Modem, then it is a "generic" Modem for which the switch setting does not matter.
- \*5 Set this switch to ON if that riser channel interface is to be used.

### SW4 (Fiber Modem Audio Expansion Board) Configuration Settings

SW4 configures Fiber Modem Audio Expansion Board. See Table 6 for settings and Figure 1 for the switch location on the modem board.

**Table 6. SW4 Switch Settings**

Position	Description	ON	OFF	Interface
1	4100 Audio Expansion	Enable	Disable	<b>4100 Audio</b>
2	Spare	-	-	
3	Spare	-	-	
4	Spare	-	-	
5	Spare	-	-	
6	Spare	-	-	
7	Spare	-	-	
8	Spare	-	-	

## Modem Configuration, *Continued*

### 4120 Network Wiring, Analog Audio, and RUI Jumper Placements

Jumper P2 configures the 4120 Network Interface according to the wire gauge to be used. Jumper P5 configures the output level & Jumper P6 configures the input level of the Channel 2 Audio Riser Interface. Jumpers P7 & P8 are RUI jumpers that can disable the x-link on a head-end modem. See Tables 7, 8, & 9 for jumper placements and Figure 1 for jumper locations on the modem board.

**Table 7. 4120 Network Jumper Placements**

Jumper	Description	Position 1-2	Position 3-4	Position 5-6	Position 7-8	Interface
*P2	4120 Network Wiring - 18 Gauge (0.8231 mm <sup>2</sup> )	X	-	X	X	4120
	4120 Network Wiring - 24 Gauge (0.2047 mm <sup>2</sup> )	No jumper placements				

\*Place Jumper P2 according to the wire gauge to be used. Note that 24-Gauge (0.2047 mm<sup>2</sup>) wiring does not require any jumpers.

**Table 8. Analog Audio Output Level Jumper Placements**

Jumper	Description	Position 1-2	Position 2-3	Interface
P5	Analog Riser Output Level - Channel 2 (1 Vp-p)	X	-	Analog Audio
	Analog Riser Output Level - Channel 2 (0.707 Vrms)	-	X	
	Analog Riser Output Level - Channel 2 (Standard 10 Vrms)	-	-	

**Table 9. Analog Audio Input Level Jumper Placements**

Jumper	Description	Position 1-2	Position 2-3	Interface
P6	Analog Riser Input Level – Channel 2 (1 Vp-p)	X	-	Analog Audio
	Analog Riser Input Level – Channel 2 (0.707 Vrms)	-	X	
	Analog Riser Input Level – Channel 2 (Standard 10 Vrms)	-	-	

**Table 10. RUI Jumper Placements**

Jumper	Description	Position 1-2	Position 2-3	Interface
*P7 & P8	RUI/X-Link (Default)	X	-	RUI
**P7 & P8	RUI/X-Link (Head-End Modem in Class A)	-	X	

\*Jumpers P7 and P8 should always be in their default position (Position 1-2) except on a head-end modem in a Class A wiring loop

\*\*For a head-end modem in Class A only, place Jumpers P7 and P8 in Position 2-3.

# Fiber Modem Audio Expansion Board

## Description

The Fiber Modem Audio Expansion Board is a module that allows the modem to interface to a 4100 audio system. It attaches to the Fiber Modem via a ribbon cable and riser wires. The 4100 audio system uses 25 or 70.7 Vrms risers. The expansion board converts these levels to 10 Vrms risers for use on the Fiber Modem.

The Audio Expansion Board mounts in either a 4100 cabinet on its mounting bracket, or in the Fiber Modem Expansion Cabinet (refer to Figure 5 and Table 1 for details). The module wires to a 4100-style signal card in either Class A or B configurations, or directly to the amplifier's output in Class A only. Refer to Figure 12 for wiring details of the expansion board. All wiring from the expansion board must be close nipped.

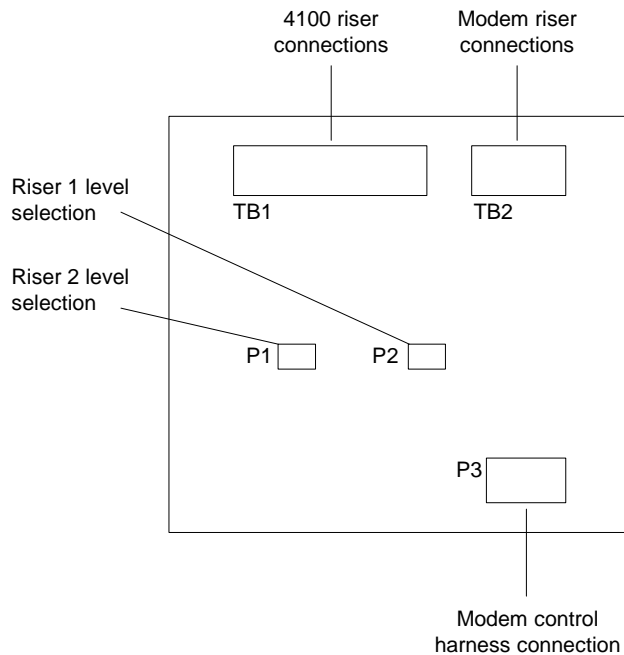

**Figure 2. Fiber Modem Audio Expansion Board**

## Jumper Configuration

Configure the jumpers on the Fiber Modem Audio Expansion Board according to Table 11.

**Table 11. Riser Level Selection Jumper Placements**

Jumper	Description	Position 1-2	Position 3-4	Position 5-6
P1	Riser 2 level select	70.7 Vrms	25 Vrms	Not used
P2	Riser 1 level select	70.7 Vrms	25 Vrms	Not used



# Mounting

## Mounting Instructions

The modem must always be mounted in a 4100U or 4100ES main panel, transponder cabinet, 4100 cabinet, Remote Expansion Cabinet (4190-9021, -9022, -9024, -9025), or any other close-nippled cabinet. It is either installed in the same manner as other standard panel 4-inch (102 mm) X 11-inch (279 mm) option cards (except that there is no PDI connection), or mounted using the mounting plate in the 4100 or any other close-nippled cabinet. In either the case, you must install the modem with the fiber optic transceiver pointing down so as to provide proper airflow to the heat sinks.

See Figure 3.

The Remote Expansion Cabinet is required when the modem is used with a 4010 or 4020 (Network Communications only application). When the modem is used with a 4100, 4100U or 4100ES system, the expansion cabinet can be used if space within the system box does not permit the installation of the modem(s) in the main cabinet. In any case, the modem must be close-nippled to its host cabinet.

In contrast, the Modem Audio Expansion Board can only be mounted in an Expansion Cabinet, in a 4100 bay using the mounting plate, or close-nippled in a transponder cabinet.

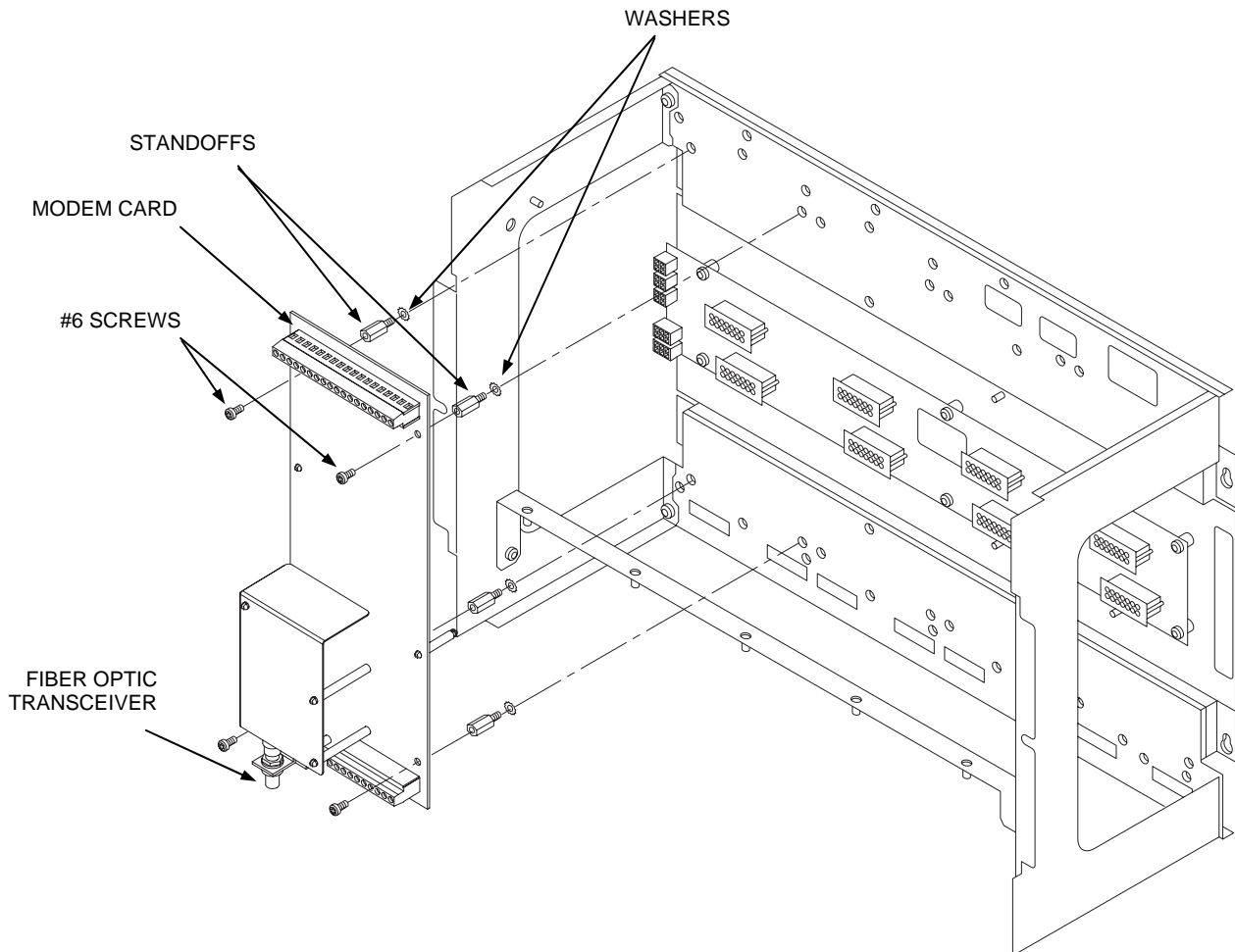

**Figure 3. Modem Card Mounting in a 4100U, 4100ES or Transponder Cabinet**

*Continued on next page*

## Mounting, *Continued*

### Mounting Instructions

The Remote Expansion Cabinet (4190-9021, -9022, -9024, -9025) comes supplied with a Fiber Optic Modem Left-Port Assembly (4100-6072, -6074) and all necessary mounting hardware. Other boards like the Audio Expansion Board (4100-9842) are optional.

To mount the modem in a Remote Expansion Cabinet with selected board options, refer to Figure 4.

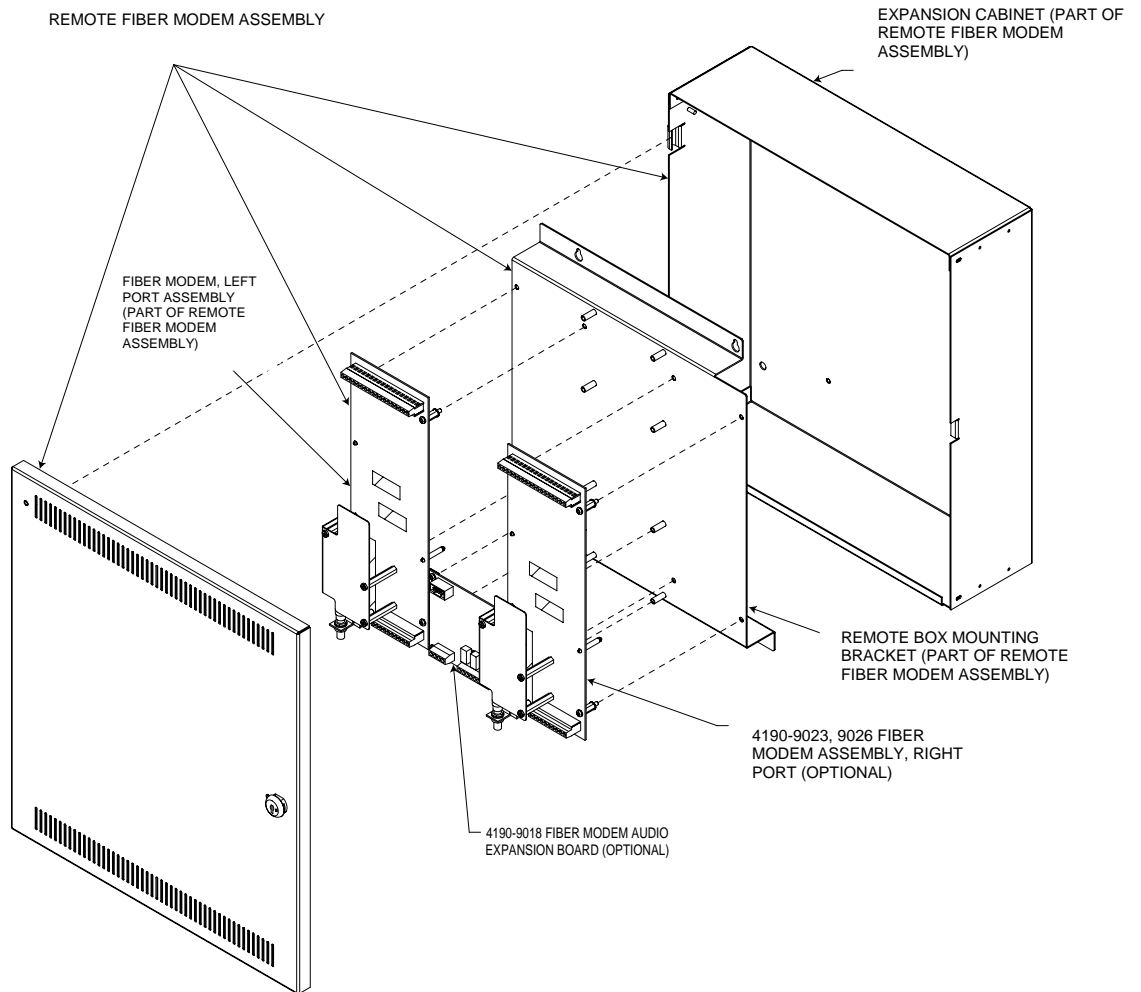

**Figure 4. Modem and Audio Expansion Board Mounting in a 4190 Remote Expansion Cabinet**

*Continued on next page*

## Mounting, *Continued*

### Mounting Instructions

To add a fiber modem audio expansion board to a 4100, see Figure 5. When mounting in any other cabinet, attach mounting plate to enclosure using self-tapping screws or equivalent. Mount the bracket first before mounting the modem and expansion board to the bracket. No standoffs are required. For the two nylon supports posts shipped with the modem, replace them with the posts shipped with the bracket.

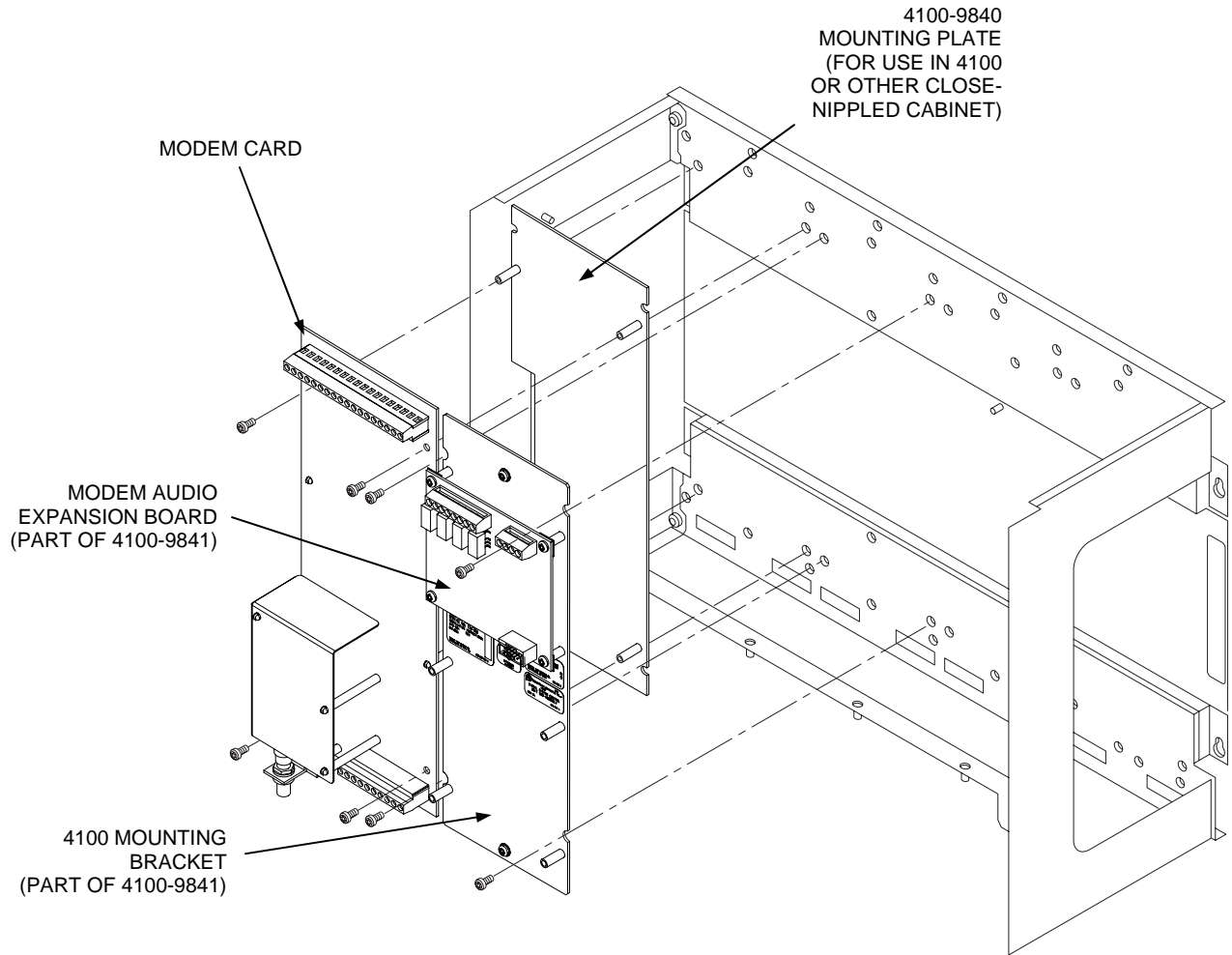

**Figure 5. Modem and Audio Expansion Board Mounting in a 4100 Cabinet or Transponder Cabinet**

# Wiring

---

## Overview

All Modem wiring is supervised and power-limited.

The following Modem wiring must be within a system box or close-nipped to a system box:

- Digital Audio Riser
- 24V Card Power
- 4120 Network Left Port
- Analog Audio Risers
- RUI

The following Modem wiring is allowed to be routed external to a system box:

- 4120 Network Right Port
- Analog Audio Riser X-link
- RUI X-link

The remainder of this section covers the actual fiber connection and then details wiring specifications with accompanying wiring diagrams for the 4120 Network, Analog Audio Riser, Digital Audio Riser (DAR), and RUI.

**Note:** Ferrite beads are required where the DAR, 4120 Network, and RUI wiring enters or exits a system box. Except for the 4120 Network Right Port and the RUI X-Link, ferrite beads for all wires are supplied with their respective equipment. Ferrite beads for the RUI X-Link and the 4120 Network Right Port are supplied with the modem (Ferrite Bead Kit Part No. 742-940.)



**Figure 6. Loop wires through bead as shown**

---

## Fiber Connection

The fiber optic cable uses a standard ST connector. When mating the connector to the Modem, be sure to align the connector's key properly to avoid any undue stress to the Modem.

**Caution:** The fiber optic cable can be damaged easily. To prevent permanent damage to the fiber, avoid bending radii smaller than 1.5 inches (38 mm), or as specified for your particular fiber optic cable.

---

## Wiring, *Continued*

---

### 4120 Network Wiring Specifications

These wiring specifications apply to the Modem's 4120 Network **Right** Port only (the Left Port must be internal or use close-nippled wiring):

The distances listed below allow for the introduction of two lightning suppressors (TEPG Part# 2081-9027) into the communication line for installations where the wiring leaves the building. These distances are shown for 18 AWG (0.8231 mm<sup>2</sup>) and 24 AWG (0.2047 mm<sup>2</sup>) wiring at 57.6Kbps and 9600Bps.

#### *57.6 Kbits per/second*

Using 18 AWG (0.8231 mm<sup>2</sup>) fire-rated, shielded, twisted-pair cable, transmission distance is: 10,000 Feet (3,048 meters) (with or without Suppressor #2081-9027).

Using 24AWG (0.2047 mm<sup>2</sup>) twisted telephone cable, transmission distance is: 7,000 Feet (2,134 meters) (with or without Suppressor #2081-9027).

#### *9600 bits per/second*

Using 18AWG (0.8231 mm<sup>2</sup>) fire-rated, shielded, twisted-pair cable, transmission distance is: 17,000 Feet (5,182 meters) (with or without Suppressor #2081-9027).

Using 24AWG (0.2047 mm<sup>2</sup>) twisted telephone cable, transmission distance is: 12,000 Feet (3,658 meters) (with or without Suppressor #2081-9027).

---

*Continued on next page*

## Wiring, Continued

### 4120 Network Wiring Specifications

The specifications for the cables to be used in order to meet the above transmission distances are as follows:

**18 AWG (0.8231 mm<sup>2</sup>) Fire-Rated, Twisted-Shielded Cable** must not exceed a capacitance between conductors of 58pF per foot and not have a DC resistance greater than 6.385 ohms per 1,000 feet (305 meters).

**24 AWG (0.2047 mm<sup>2</sup>) Twisted, Unshielded Telephone Cable** must not exceed a capacitance between conductors of 22pF per foot and not have a DC resistance greater than 25.6 ohms per 1,000 feet (305 meters).

When using twisted-shielded pair, the shield is to be connected to Earth ground (Chassis). It is recommended that the shield be connected to Earth ground at one end of the link only (Left Port). When terminating the shield to Earth Ground, it is also preferable to connect it on the chassis as close to the exiting point of the back box as possible. Earth ground is also available on the external terminal block, and on the host's port connectors. When using 0 V in lieu of Earth ground for shield connection, only one end of the link should be connected (Left Port).

Refer to Figure 7 for Modem to 4120 Network wiring information.

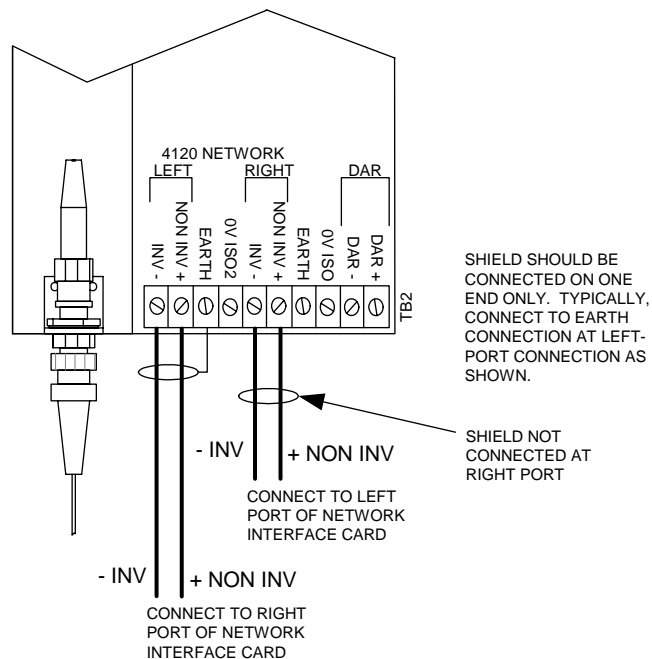

Figure 7. Modem to 4120 Network Wiring Diagram

## Wiring, *Continued*

---

### Analog Audio Riser Wiring Specifications

These wiring specifications apply to the Modem's Analog Audio Riser Wiring.

- Analog Riser wiring to/from the Modem must connect to either an Analog Audio Controller or an Analog Audio Riser Interface card.
- The Analog Riser X-link can be wired external to the system box, and is part of the head-end side of the wiring loop (that part of loop - 10,000-foot [3,048-meter] limitation).
- All wiring is 18 AWG (0.8231 mm<sup>2</sup>) to 14 AWG (2.081 mm<sup>2</sup>), twisted-shielded pair.
- Audio wiring is not to be mixed in the same jacket with other wiring (including other audio wiring).
- AC voltage rating: 10 VRMS (maximum).
- DC voltage rating: 1 VDC (maximum).
- Maximum number of analog interface cards per audio riser: 31.
- Maximum of six pairs of Modems in series using standard analog audio.
- All wiring that leaves the building requires the 2081-9044 Overvoltage Protector at each entry or exit to the building.
- Maximum wire distance: 10,000 feet (3,048 meters) per copper wired section (for example, a 10,000-foot [3,048-meter] loop of copper could be connected to another 10,000-foot [3,048-meter] loop of copper **if** the two loops were electrically isolated via fiber optic cable).
- Wiring must be free of all grounds.
- All riser wiring is supervised and power-limited.
- "T" tapping is not allowed from the Modem.
- The DAR interface wiring, when used for Enhanced Analog Audio (EAA), must be close nipped because it is not supervised.

Refer to Figure 8 for Modem to Analog Audio Riser wiring information and Figure 9 for Modem to Enhanced Analog Audio Riser wiring information.

---

*Continued on next page*

# Wiring, Continued

## Analog Audio Riser Wiring Specifications

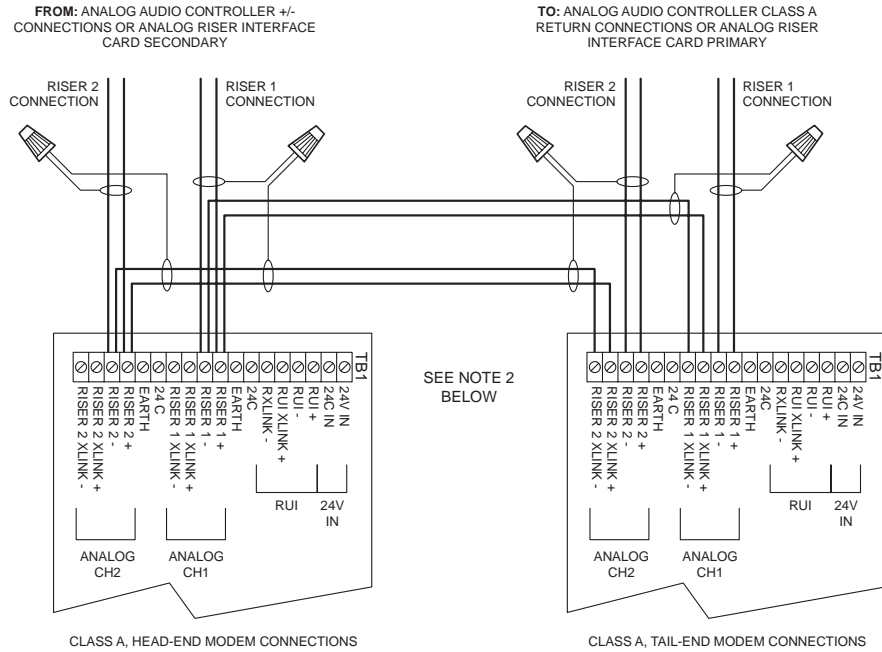

- Note 1:** On the head-end modem in a Class A analog audio wiring loop, it is necessary to provide wired connections between the riser's terminal block positions and the x-link as shown in this diagram. If using 18 AWG (0.8231 mm<sup>2</sup>) or smaller wire, then make connections as indicated in this diagram. If using wire larger than 18 AWG (0.8231 mm<sup>2</sup>), then insert a short piece of wire into the terminal block positions and connect the riser and x-link wiring using a wire nut.
- Note 2:** For Enhanced Analog Audio (EAA) systems, do not make Riser 2 connections.

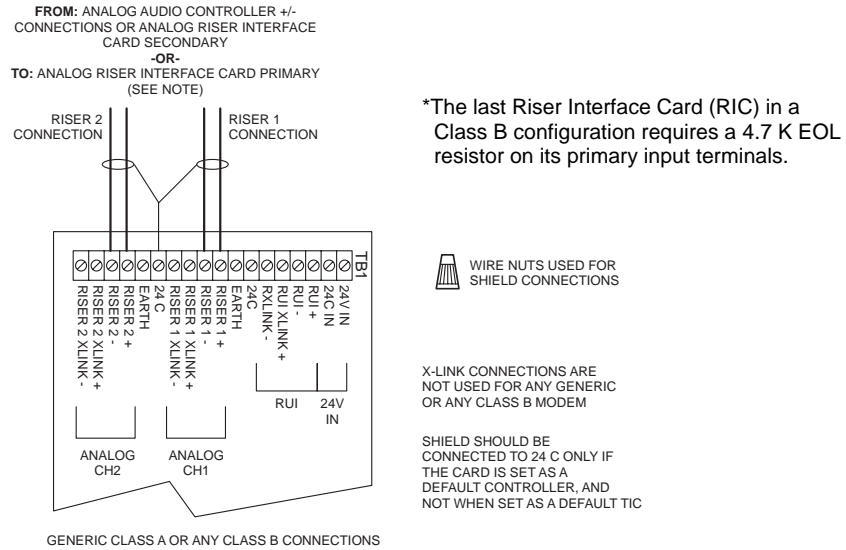

**Figure 8. Modem to Analog Audio Riser Wiring Diagram**



## Wiring, Continued

### Enhanced Analog Audio (EAA) Riser Wiring Specifications

Enhanced Analog Audio (EAA) eliminates the restriction on the number of modem pairs that can be used in an analog audio system. In an EAA system, you can use only Riser 1 (Channel 1). EAA does not affect the content of the analog riser; it only affects the format of transmission throughout the modem chain.

**Note:** In an EAA system, modems transmit the analog riser via the EAA wiring or the riser channels. If riser channels are used to pass the riser, the maximum number of modem pairs passing the riser over the riser channels is limited to six.

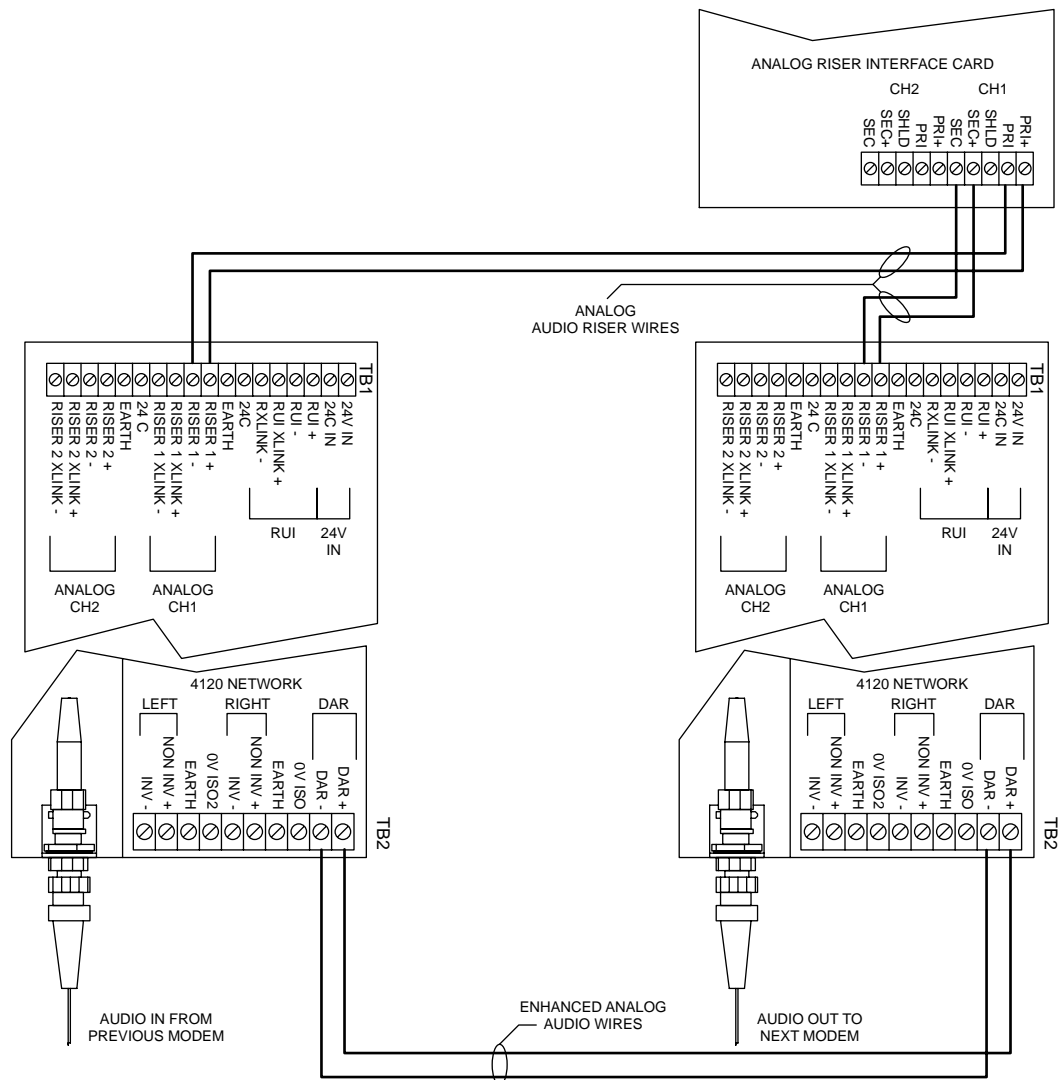

**Figure 9. Modem to Enhanced Analog Audio Riser Wiring Diagram**

*Continued on next page*

# Wiring, Continued

## Enhanced Analog Audio (EAA) Riser Wiring Specifications

### EAA Combinational System

In some analog audio systems, more than six modem pairs might be required (therefore requiring EAA usage), but the topology will not allow for all modem-to-modem connections to be close nipped. You are permitted to have modem-to-modem connections made with external wiring; however, those links will not be using the EAA feature and therefore, will be counted toward the limit of six Standard Analog Audio modem pairs in a system. The example in Figure 10 shows such a system where connections between buildings are made with fiber, and intra-building connections are made with field wiring. Note that since EAA is used in the system, the restrictions it imposes apply to the entire analog audio system. Refer to Analog Audio Riser Overview section that appears earlier in this publication.

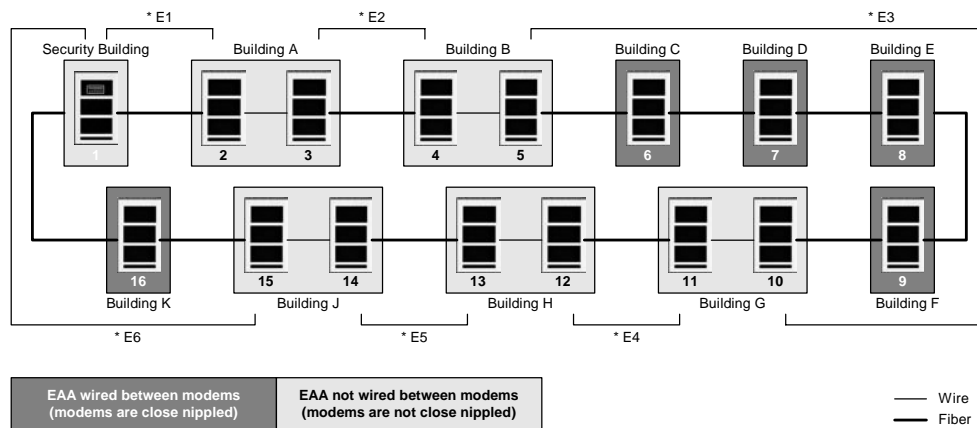

\* E = EAA link. The bracketed fiber links have EAA wired close nipped between them. Multiple modem links can be counted as a single link for the purposes of calculating the total number of Standard Analog Audio links in a system (e.g. E3 above can be counted as one link even though it consists of 5 modem pairs).

Example of internal wiring in the system above:

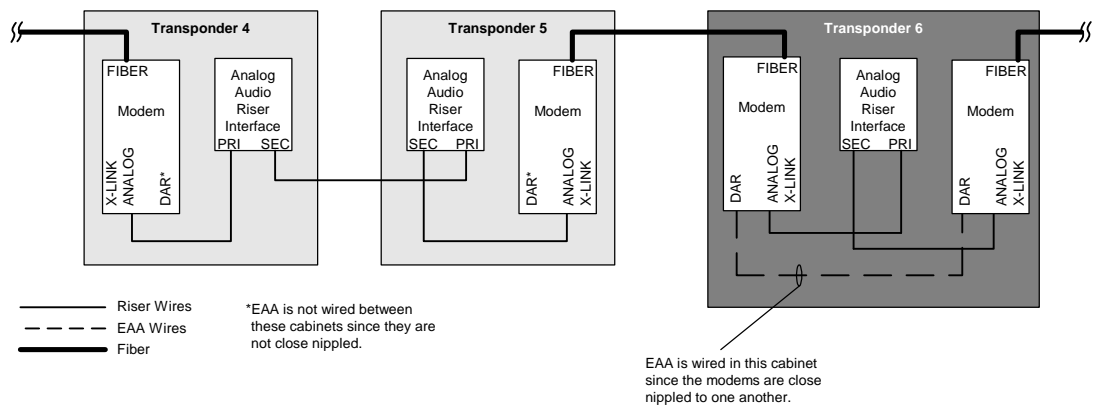

Figure 10. Enhanced Analog Audio Combinational System Wiring Diagram

# Wiring, Continued

## Digital Audio Riser Specifications

These wiring specifications apply to the Modem's Digital Audio Riser Wiring.

The Digital Audio Riser (DAR) wiring is *always* within a system box or close-nipped to a system box. The DAR connection is always either to a Digital Audio Controller or a Digital Audio Riser Interface card.

- All riser wiring is supervised and power-limited.
- Do not mix audio wiring in the same jacket with other wiring (including other audio wiring).
- Maximum number of digital audio interface cards per audio riser: 31.

Refer to Figure 11 for Modem to Digital Audio Riser wiring information.

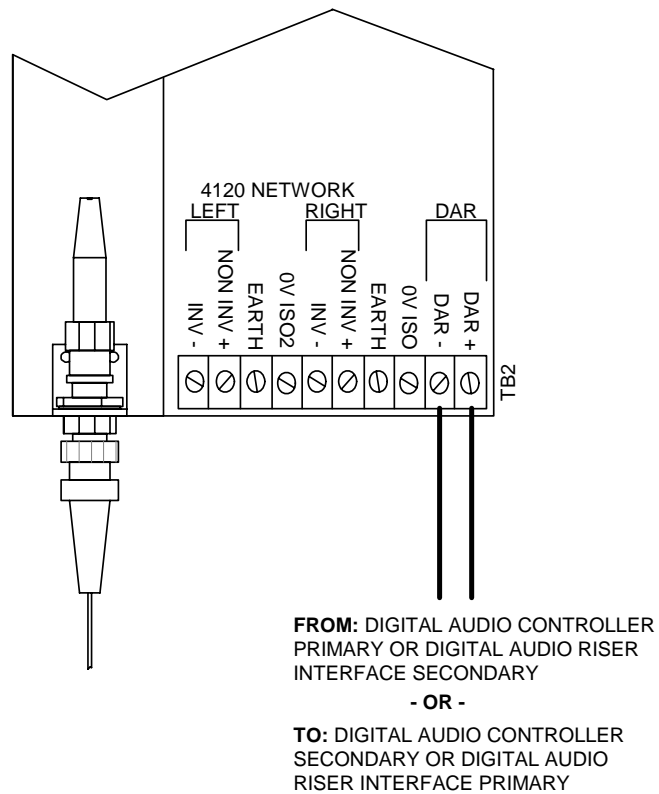

**Figure 11. Modem to Digital Audio Riser Wiring Diagram**

## Wiring, *Continued*

---

### RUI Wiring Specifications

These wiring specifications apply to the Modem's RUI Wiring.

- RUI wiring to/from the Modem must connect to either a CPU/RUI card or a Transponder Interface card.
- The RUI X-link can be wired external to the system box, and is part of the head-end side of the wiring loop (that part of loop - 2,500 foot [762-meter] limitation).
- Wire size must be between 18 AWG (0.8231 mm<sup>2</sup>) and 12 AWG, (3.309 mm<sup>2</sup>).
- Maximum wiring distance: 2,500 feet (762 meters) per copper wired section (for example, a 2,500-foot [762-meter] loop of copper could be connected to another 2,500-foot [762-meter] of copper **if** the two loops were electrically isolated via fiber optic cable).
- "T" tapping is not allowed from the Modem.
- Maintain correct polarity on terminal connections.
- Do not loop wires under terminals.
- All RUI wiring is supervised and power-limited.
- All wiring that leaves the building requires the 2081-9044 Overvoltage Protector at each entry or exit to the building.
- Maximum of eight pairs of Modems for RUI if wired Class A.

Refer to Figure 12 for Modem to RUI wiring information.

---

*Continued on next page*

# Wiring, Continued

## RUI Wiring Specifications

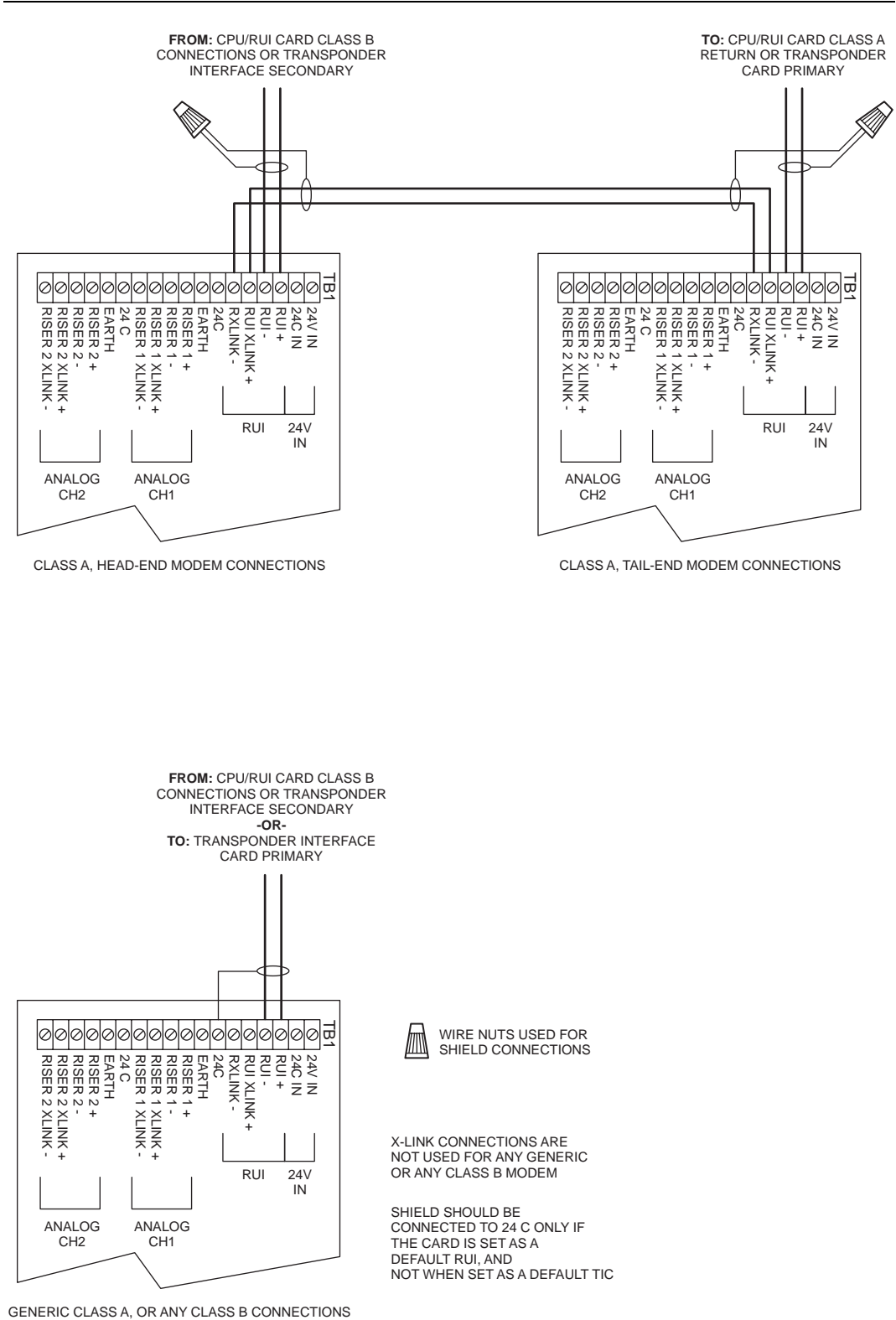
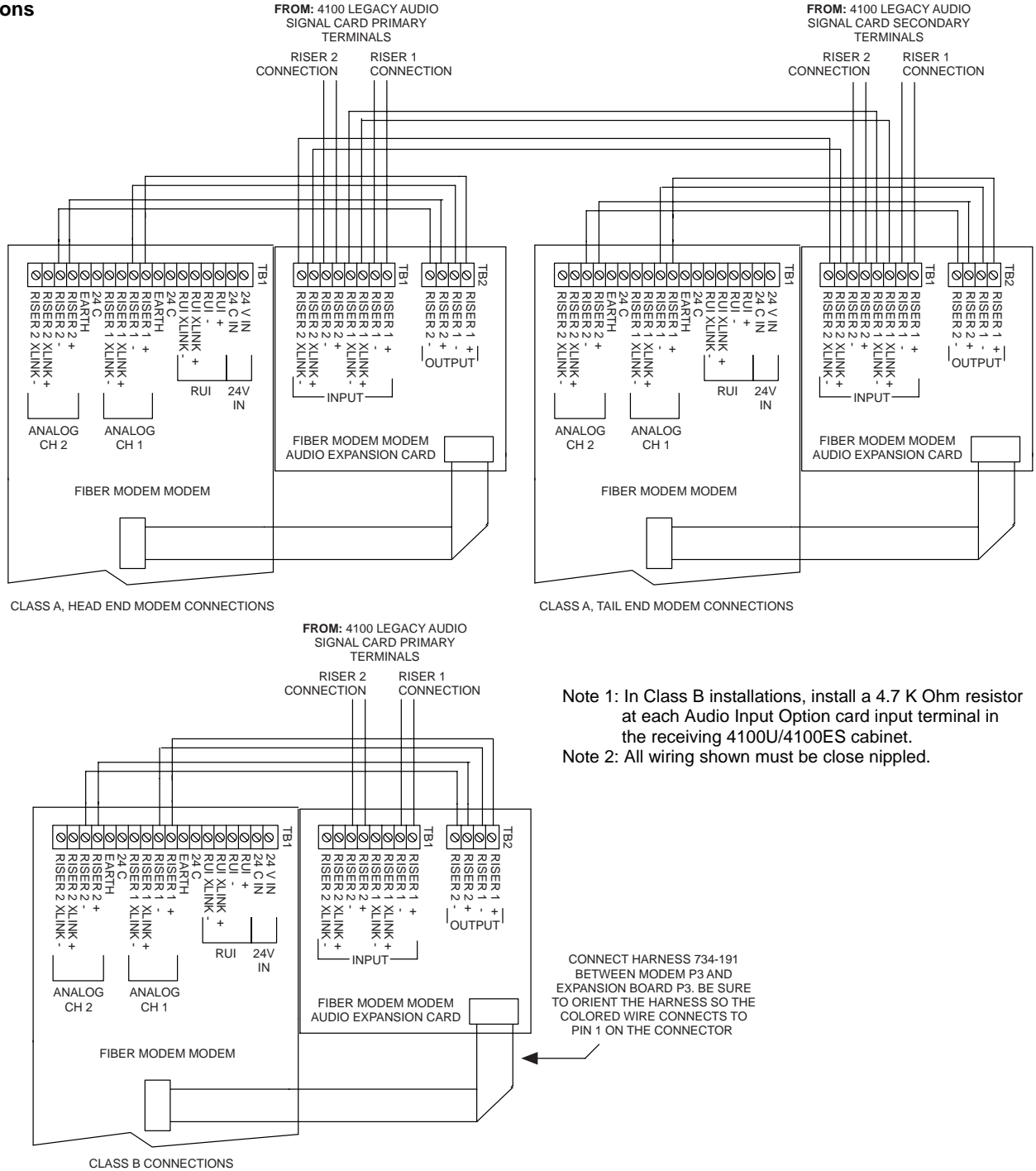

**Figure 12. Modem to RUI Wiring Diagram**

# Wiring, Continued

## Fiber Modem Audio Expansion Board Wiring Specifications

All wiring shown in Figure 13 must be close nippedled.



Note 1: In Class B installations, install a 4.7 K Ohm resistor at each Audio Input Option card input terminal in the receiving 4100U/4100ES cabinet.  
 Note 2: All wiring shown must be close nippedled.

Figure 13. Modem Audio Expansion Board Wiring Diagram

# Connecting Power to the Modem

---

## Where to Connect Power

### **4100U and 4100ES**

The Modem has two Core 4 connectors (P9 & P10) and a terminal block (TB1) for connecting 24 VDC power. (See Figure 1 and Figure 14 [on next page] for locations of Connectors P9 & P10 and Terminal Block TB1.) The source of card power to the Modem must be an uninterruptible source (such as card power), and not a resettable source such as AUX power. The Modem's power must not be interrupted because all wired interfaces would fail during the power failure (roughly equivalent to disconnecting all the attached wires for the duration of the power failure). The intended installation in a 4100U or 4100ES system is to use Connectors P9 & P10. Because these two connectors are electrically identical, power can be daisy chained as needed in and out of the Modem. The connection can be made using a standard PDI bay-to-bay harness. Make your connection to the mating connector on the local power supply (SPS, RPS, or XPS). If the connector on the power supply is occupied (as may be the case in a Miniplex Transponder cabinet), then connect the Modem power harness to one of the PDI connectors on the PDI to which the power supply is connected.

**NOTE:** Do not use the daisy-chain connections for anything except modems. The communication-wiring portion of the harness is not connected to the modem and is not daisy chained between the connectors.

### **4100 (Audio [Expansion Board] and 4120 Network Only)**

When connecting power to a 4100 system, connect TB1-1 and TB1-2 on the Modem to the system power supply:

- 24V...TB2-11 or TB2-12
- 0 V....TB2-9 or TB2-10

### **4010 (4120 Network Only)**

When connecting power to a 4010 system, connect TB1-1 and TB1-2 on the Modem to auxiliary power (TB5) on the system board.

### **4020 (4120 Network Only)**

When connecting power to a 4020 system, connect TB1-1 and TB1-2 on the Modem to the "A" tap on the Power Interface Board. Connect to TB2 as follows:

- 24V...TB2-1 or TB2-2
- 0 V....TB2-3 or TB2-4

---

*Continued on next page*

# Connecting Power to the Modem, *Continued*

Where to Connect Power

4100U/4100ES

Connects to local power supply:  
 SPS P6  
 RPS P6  
 XPS P2  
 If that connector is occupied:  
 PDI P2 or P3

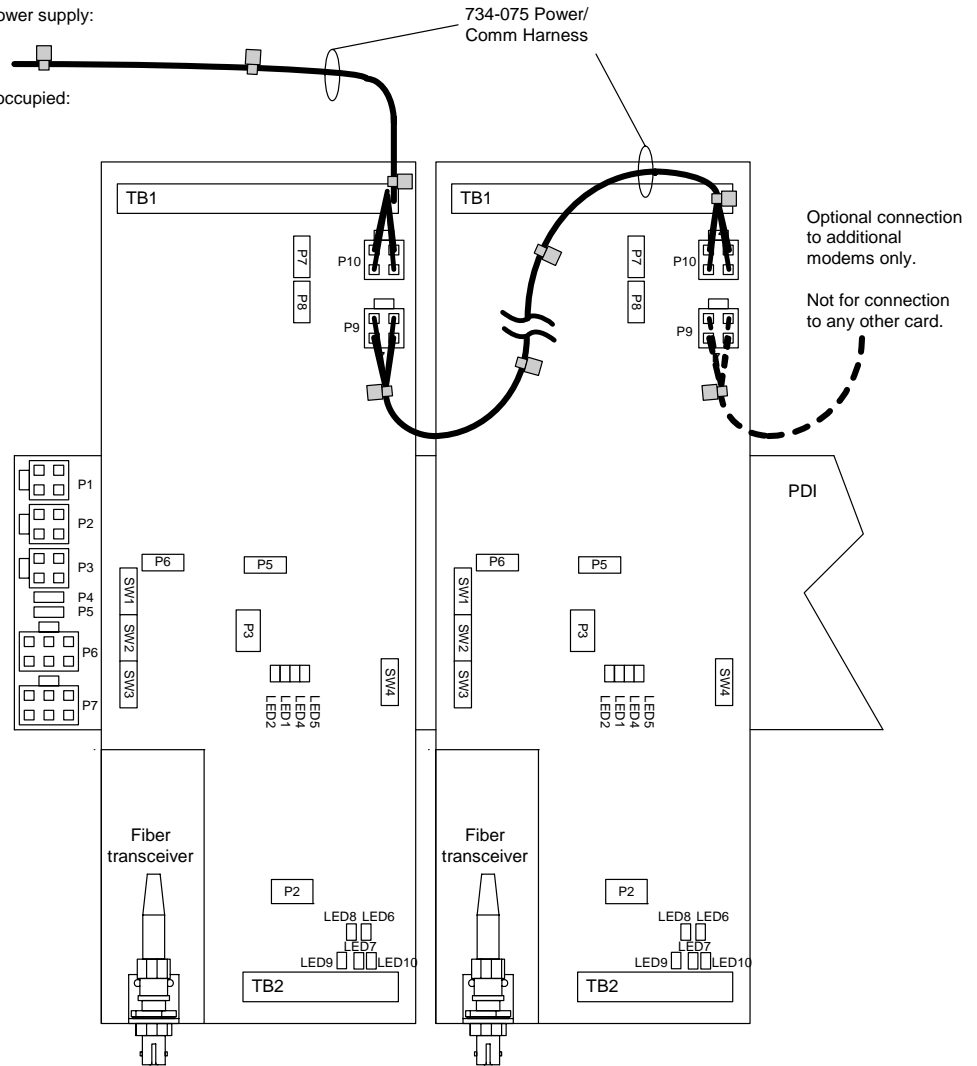

Figure 14. Modem Power Connections



# Testing and Troubleshooting

## General

---

Use this section as an aid in testing and troubleshooting a fiber modem pair installation. It should be noted that a fiber fault can cause a trouble on all connected media. A fiber fault must be resolved before any further troubleshooting or testing can be performed. The following general checkouts should always be performed upon installation of modem pair:

1. Verify that the “Fiber Fault” LED is not illuminated. If it is not, then the fiber connection is operating. (See Table 12 and the Fiber Fault LED section [next page] for details on LED indications.) If it is illuminated, verify the following:
  - a. The modems are actually a mated pair. Perform this action by checking the assembly number of the fiber optic transceiver board that mounts to the main board. For multimode fiber, one transceiver should be 566-714 (left port), and the other should be 566-715 (right port). For single-mode fiber, one transceiver should be 566-716 (left port), and the other should be 566-717 (right port).
  - b. The fiber optic cable is properly connected, and the connections are clean.
  - c. The total attenuation and distance are within limits.
  - d. If all of the above conditions are met and the Fiber Fault LED is still illuminated, then it may be necessary to test the link using an OTDR. OTDR tests should be done using industry standard methods and industry standard pass/fail criteria.
2. Verify that the switch configurations are properly set. If the switches are set improperly, the modem may not be in the proper mode, and may not be capable of entering a degraded mode or successfully report troubles to the connected equipment.
3. Verify that the wired connections are in the proper terminal block positions. For RUI and Analog Audio (if used), be certain that the risers connect to the RUI and Riser positions and not the x-link connections. The only time anything should be connected to the x-link connections is in a Class A system between the head and tail-end modems.

**Note:** All wiring faults (shorts *and* opens) on a wired loop that is electrically isolated from the main panel by fiber *will always be reported as an open* on the panel side of the loop. Modems report this way to convey fault information back to the panel without causing a short circuit on the panel side of the loop.

---

## Testing and Troubleshooting, *Continued*

### LED Indications

The Modem has LED indicators as shown in Table 12. Refer to Figure 1 for LED locations.

**Table 12. LED Indications**

Reference	Function	Details
LED1	AAR1 FAULT	Indicates a fault condition on Analog Audio Riser Channel 1.
LED2	AAR2 FAULT	Indicates a fault condition on Analog Audio Riser Channel 2.
LED3	FIBER FAULT	Indicates a failure of the fiber optic link.
LED4	RUI FAULT	Indicates a fault condition on RUI.
LED5	POWER	Indicates the presence of 24V card power.
LED6	4120 TX R	Flashes while data is actively being transmitted on the right network port.
LED7	4120 RX R	Flashes while data is actively being received on the right network port.
LED8	4120 TX L	Flashes while data is actively being transmitted on the left network port.
LED9	4120 RX L	Flashes while data is actively being received on the left network port.
LED10	DAR TX	ON when DAR transceiver is in transmit mode. OFF when in the receive mode. Flashes when the Modem is searching for an active DAR (fault if flashing).

Note: The RUI and Analog Riser LEDs are intended as troubleshooting aids only. In some configurations, they will not indicate a fault on their wiring.

### Fiber Fault LED

There are two severity levels for fiber faults. One level is a momentary fault that's indicated by the fiber fault LED for any data error on the fiber. In a properly operating fiber link, momentary faults occur very rarely or never. If the fiber fault LED illuminates frequently (e.g., more than once in five minutes), then there may be a problem with the fiber link. The other level of fault is a fiber trouble. In this case, troubles are reported at the panel and the fiber fault LED illuminates much of the time or continuously; you definitely need to check out the fiber link. The goal for any link during installation is to have no illumination of the modem's fiber fault LED.

### Digital Audio Riser (DAR)

Use the "DAR TX" LED to aid in diagnosing DAR faults. If the DAR LED is OFF, then the DAR is in the receive mode. It remains in the receive mode if the DAR is not enabled or if the modem is actively receiving a DAR on the wired connection. If the DAR LED is ON, then the modem is actively transmitting a DAR on the wired connection. If the DAR LED turns ON and OFF at a 2-second rate, then the modem is searching to find a DAR on the fiber and the wired interface.

In the event of a DAR fault, check the following:

1. The DAR enable switch is properly set.
2. The DAR LED is OFF on a modem receiving the DAR from the wired interface.
3. The DAR LED is ON for a modem transmitting the DAR to the wired interface.

## Testing and Troubleshooting, *Continued*

---

### Analog Audio

If the analog audio interface is not operating properly, verify the following:

1. The analog audio switches are properly set.
2. A good quality voltmeter can be used to measure the riser's RMS voltage on the panel side loop, and then be re-measured on isolated loops to determine what modem pair could be causing a fault. Any signal present on one side of a fiber connection should be present on the other.
3. The wired interface is connected to the proper terminal block positions.
4. The analog audio level select jumpers are properly set.

**Note:** A fault on the analog audio interface could result from a fault on a separate-wired interface, and could be induced by a connected modem that's indicating to the panel that there is a fault on an isolated wired loop.

---

### 4120 Network

If the network interface is not operating properly, verify the following:

1. The network switch settings are all properly configured.
  2. The network connections are in the proper ports. A given network wire pair should always enter either the left or right port of a modem, and leave via the mating modem's opposite port (for example, in on left, out on right, or vice versa).
  3. The network interface LEDs operate in the same way as those found on a network interface card; that is, the TX and RX LEDs illuminate only while data is actively being passed in their respective directions.
- 

### RUI

If the RUI interface is not operating properly, verify the following:

1. The RUI configuration switches are properly set.
2. The wired interface is connected to the proper terminal block positions.

**Note:** A fault on RUI interface could result from a fault on a separate-wired interface, and could be induced by a connected modem that's indicating to the panel that there is a fault on an isolated wired loop.

---

### System Checkout

A basic system checkout should always be performed on a new installation to verify that all modems are properly configured. Do a basic checkout because a wrongly configured modem could behave normally in normal mode, but not be capable of entering degraded mode or reporting troubles to the panel. Basic tests include introducing shorts and open circuits on each of the wired links within a system as well as interrupting each fiber optic link and verifying system operation.

---

## Testing and Troubleshooting, *Continued*

### Testing Circuit Supervision

Use the procedures in the Table 13 to confirm that all interfaces (that are in use) are supervised for opens, shorts, and grounds. The left two columns indicate the interface/test method while the right column indicates the system response.

**Table 13. Testing Circuit Supervision**

Interface	Test Condition	Corresponding System Indication/Response
Digital Audio Riser	Short - apply a zero ohm jumper across the riser wires.	Panel indicates riser trouble at receiving cards. System enters degraded mode if wired Style 7.
Digital Audio Riser	Open - open the riser wires.	Panel indicates riser trouble at receiving cards. System enters degraded mode if wired Style 7.
Digital Audio Riser	Ground - place a 10 K or smaller value resistor from supervised wiring to earth ground.	Panel indicates earth ground and riser trouble at receiving cards. System enters degraded mode if wired Style 7.
Analog Audio Riser	Short - apply a zero ohm jumper across the riser wires.	Panel indicates a short if the jumper is on the local side of wiring loop, or an open if the jumper is on the remote side of the loop. Class A only: If the short is optically isolated from the head-end panel, then the system enters degraded mode.
Analog Audio Riser	Open - open the riser wires or remove the End-Of-Line resistor (Class B only).	Panel indicates an open if Class B. If wired Class A, enters degraded mode (indicates Class A fault).
Analog Audio Riser	Ground- place a 10k or smaller value resistor from supervised wiring to earth ground.	Panel indicates earth ground.
4120 Network	Short - apply a zero ohm jumper across the network wires.	Panel indicates network trouble. System enters degraded mode if wired Style 7.
4120 Network	Open - open the network wires.	Panel indicates network trouble. System enters degraded mode if wired Style 7.
4120 Network	Ground - place a 10 K or smaller value resistor from supervised wiring to earth ground.	Panel indicates earth ground and network wiring fault trouble. System enters degraded mode if wired Style 7.
RUI	Short - apply a zero ohm jumper across the RUI wires.	Panel indicates cards missing if it is wired Class B. If wired Class A, the system enters degraded mode (indicates Class A fault).
RUI	Open – open the RUI wires.	Panel indicates cards missing if it is wired Class B. If wired Class A, the system enters degraded mode (indicates Class A fault).
RUI	Ground - place a 10 K or smaller value resistor from supervised wiring to earth ground.	Panel indicates earth ground.

# Appendix – Sample Configurations

## Overview

This section shows sample configurations for each interface. Pages 29, 35, 40, and 44 show high-level drawings while the drawings on subsequent pages show detailed implementation.

Internal Building or Multi-Building Configurations...Figures A-1 through A-12

Hub Configurations...Figures A-13 through A-15

Interconnected Loop and Star Configurations...Figures A-16 through A-19

Fiber-Connected Information Management System (IMS) Configuration...Figure A-20

Fiber Modem Audio Expansion Board...Figures A-21 and A-22

## Internal Building or Multi-Building Configuration – Class A/Style 7 or Style 6

- Multiple panels (4) in one building
- Multiple buildings (4) each with one panel

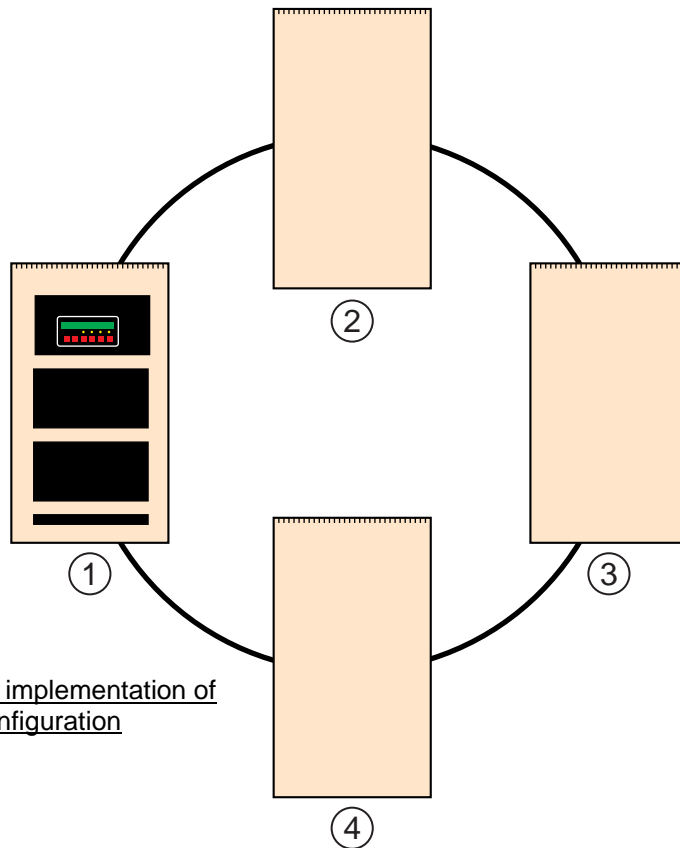

Refer to the following pages for detailed implementation of the Internal Building or Multi-Building Configuration (Class A/Style 7 or Style 6):

RUI	Page 32
4120 Network	Page 33
Analog Audio	Page 34
Enhanced Analog Audio	Page 35
Digital Audio	Page 36

**Figure A-1. Internal Building or Multi-Building Configuration Class A/Style 7 or Style 6**

# Appendix – Sample Configurations, *Continued*

## RUI (excluding 4120 Network) Class A/Style 7

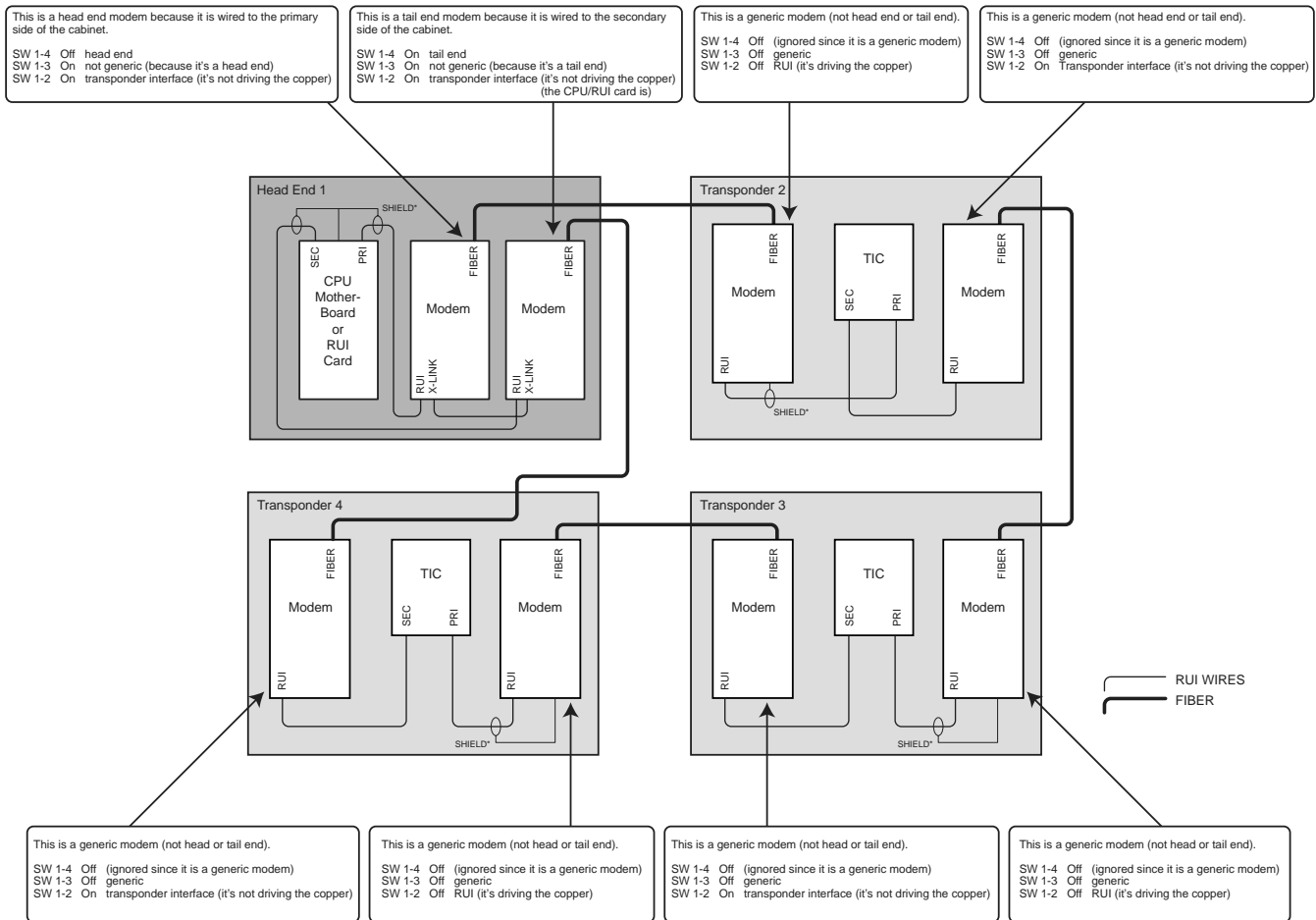

Switch 1-5 (Enable RUI interface) and Switch 1-1 (Class A wiring) both ON for all modems in this configuration.

\*Shields are to be connected at one end of each wiring link to either Earth or 24C as required.

Ferrite beads must be installed at the point where copper wiring exits the system box.

Note: All switches not listed are set according to the application of their respective interface.

**Figure A-2. RUI Class A/Style 7**

## Appendix – Sample Configurations, *Continued*

### 4120 Network (excluding RUI) Class A/Style 7

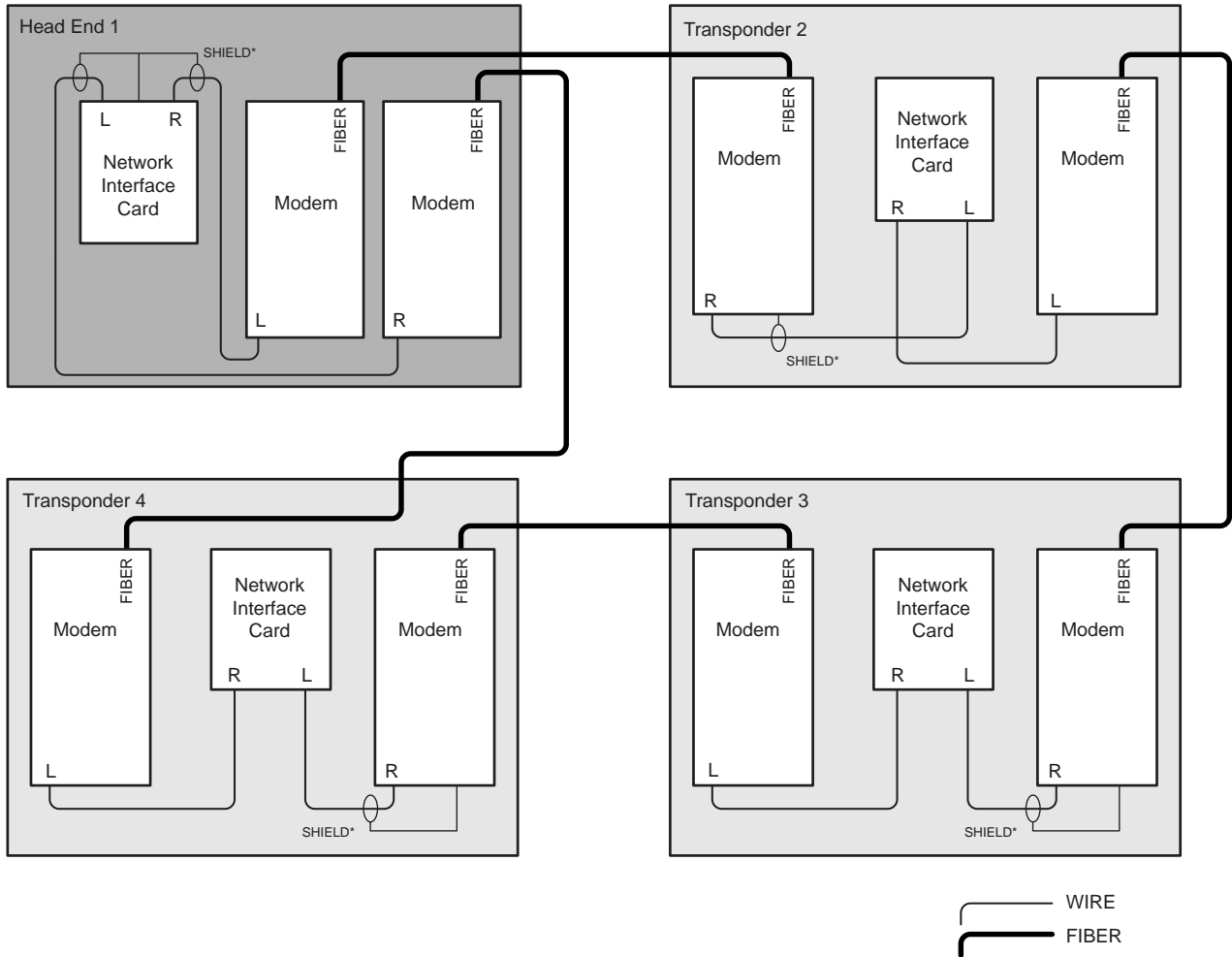

Switch 1-5 OFF to enable the 4120 Network Interface.

SW1-6 (4120 Network Protocol) and Switch SW1-7 (4120 Network Speed) are set the same for all modems in the system. They are set to match the Network Interface Cards (NICs) in the system.

Note: All switches not listed are set according to the application of their respective interface.

Refer to Figure 4 for shield connections.

**Figure A-3. 4120 Network Class A/Style 7**

# Appendix – Sample Configurations, Continued

## Analog Audio Class A/Style 6

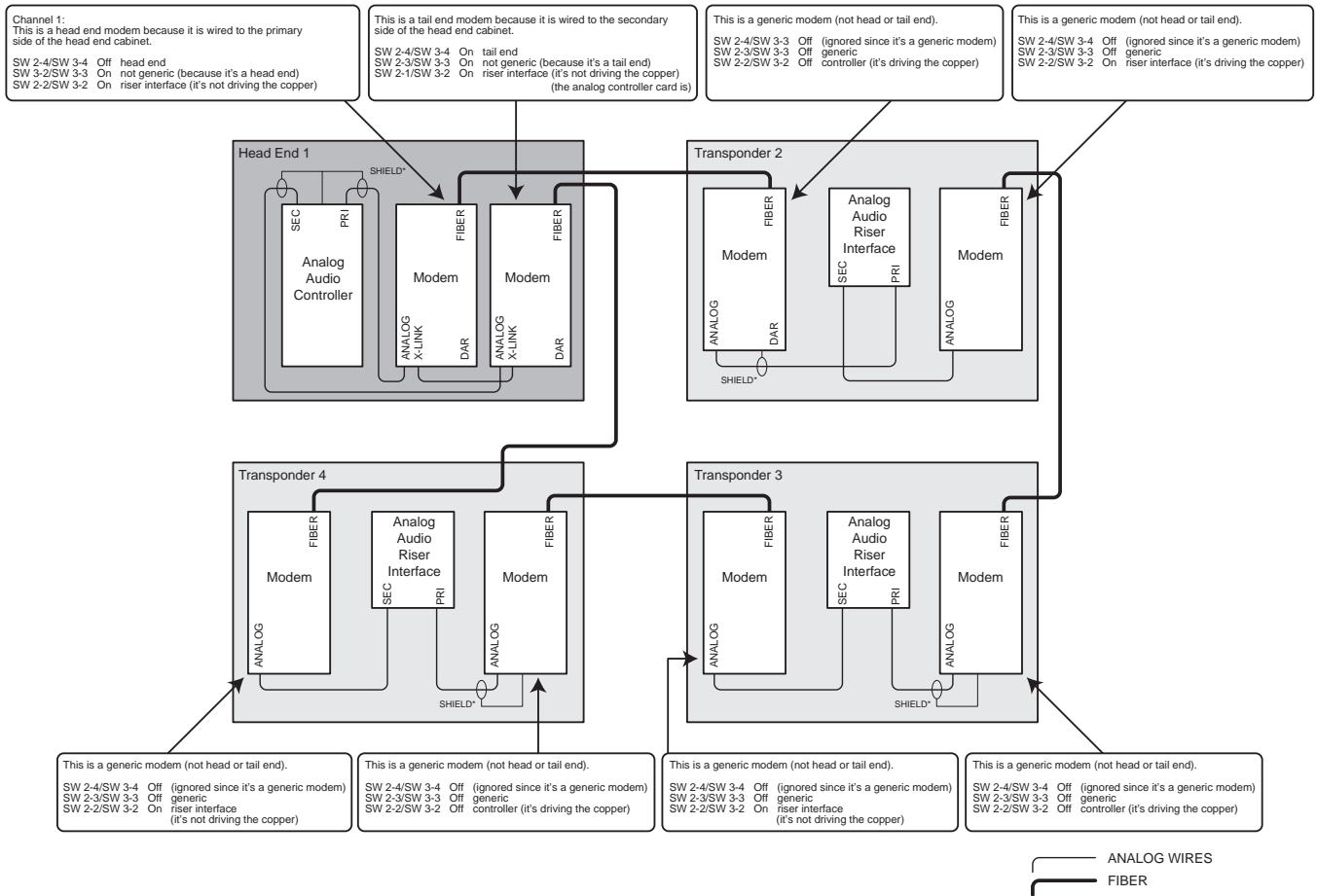

SW2-5, SW3-5 (Analog Channel Enable) and SW2-1, SW3-1 (Class A wiring) both ON for all modems in this configuration.

\*Shields are to be connected at one end of each wiring link to either Earth or 24C, as required.

Ferrite beads must be installed at the point where copper wiring exits the system box.

Note: All switches not listed are set according to the application of their respective interface.

Switch positions are indicated as follows: "Riser 1 position/Riser 2 position."

Figure A-4. Analog Audio Class A/Style 6



# Appendix – Sample Configurations, *Continued*

## Enhanced Analog Audio (EAA) (limited to Channel 1 & excluding Digital Audio) Class A/Style 6

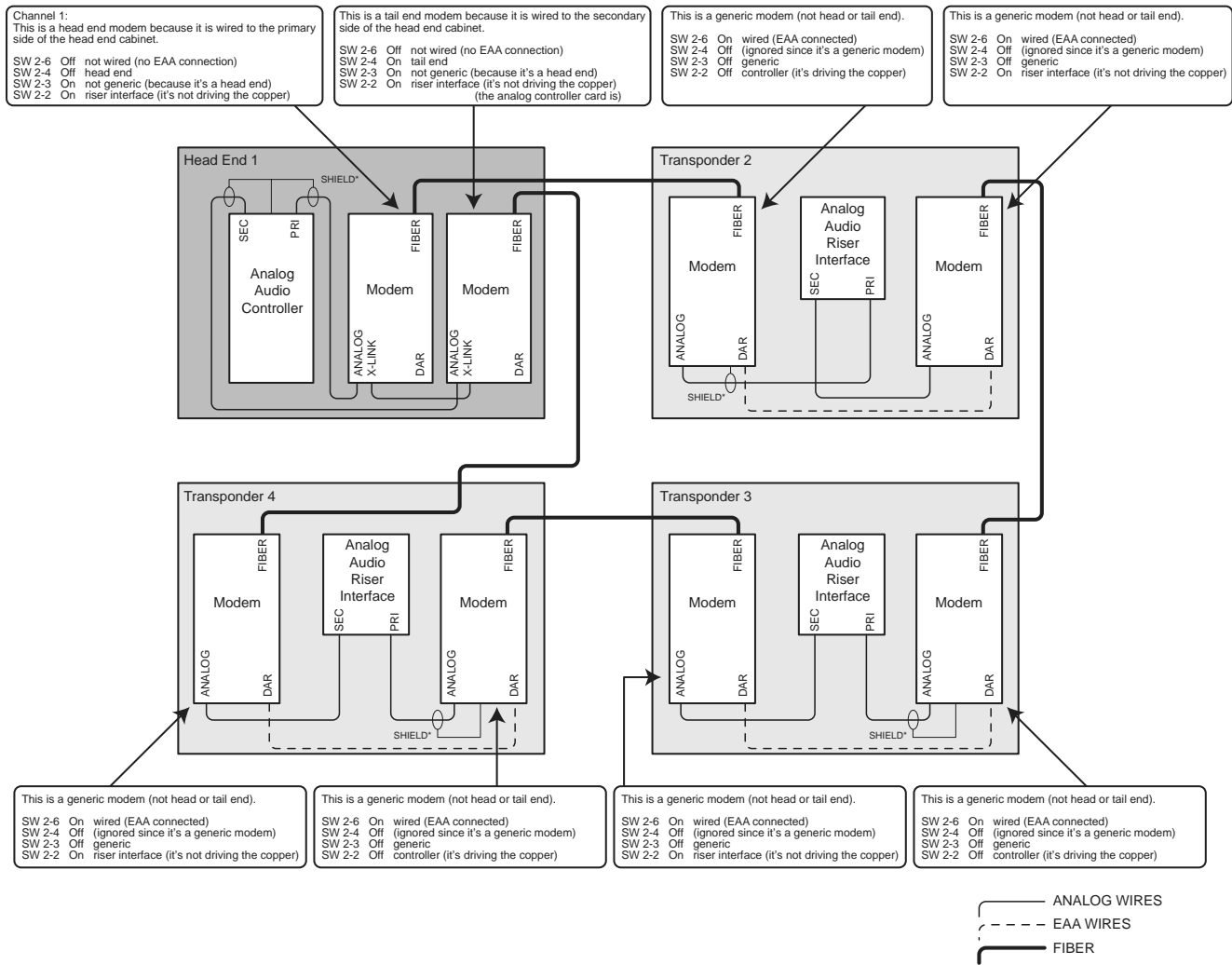

SW2-1 (Class A) ON for all modems in this configuration.  
 SW2-5 (Analog Enable) ON for all modems in this configuration.  
 SW2-7 (Enhanced Analog Enable) ON for all modems in this configuration.  
 Note: All switches not listed are set according to the application of their respective interface.

**Figure A-5. Enhanced Analog Audio (EAA) Class A/Style 6**

## Appendix – Sample Configurations, *Continued*

### Digital Audio (excluding Analog Audio Channel 1) Class A/Style 7

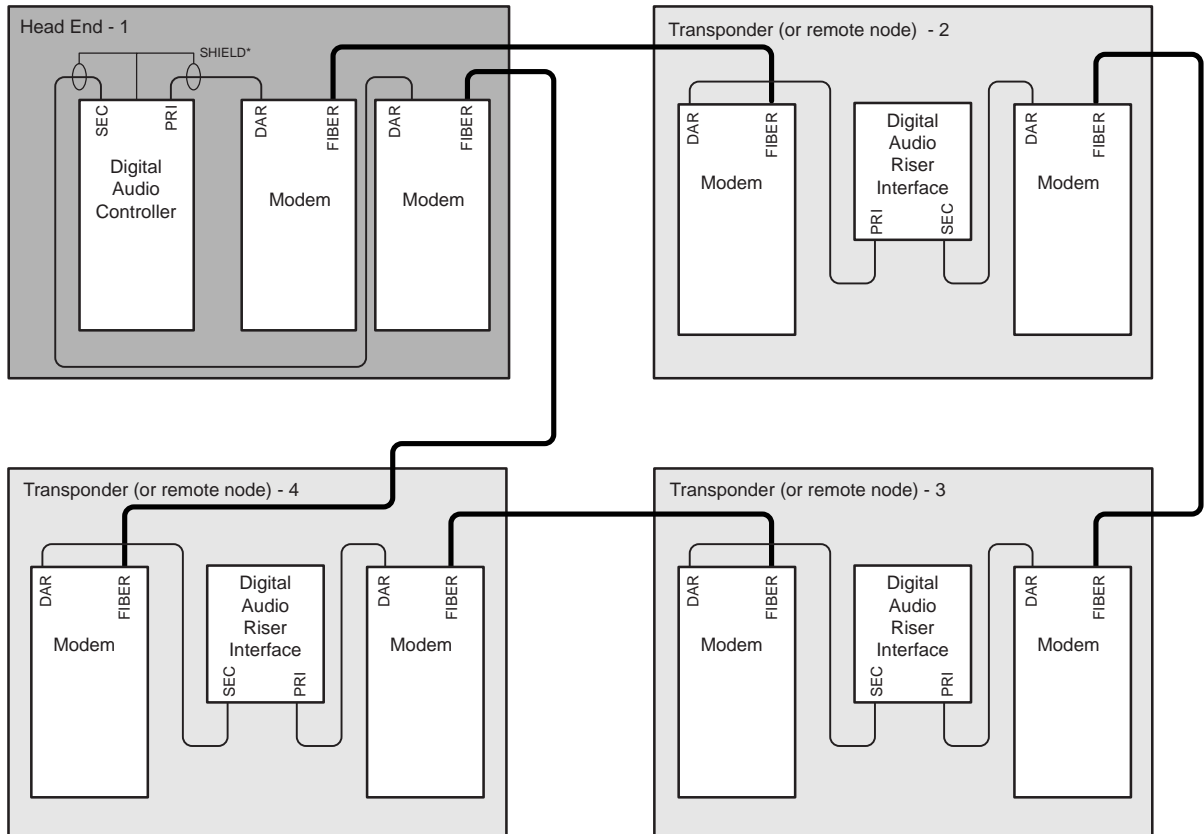

**Settings for all switches in this configuration:**

Switch 2-8 (DAR Enable) ON for all modems in this configuration.

Note: All switches not listed are set according to the application of their respective interface.

**Figure A-6. Digital Audio (excluding Analog Audio Channel 1) Class A/Style 7**

## Appendix – Sample Configurations, *Continued*

---

### Internal Building or Multi-Building Configuration – Class B/Style 4

- Multiple panels (4) in one building
- Multiple buildings (4) each with one panel

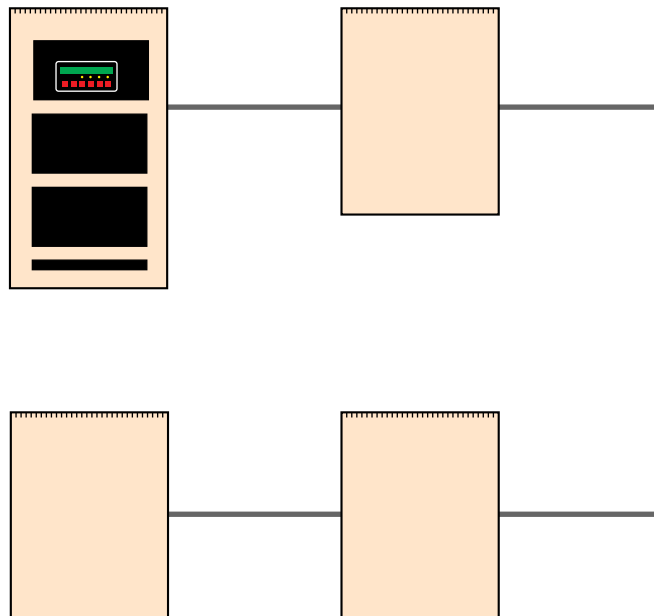

Refer to the following pages for detailed implementation of the Internal Building or Multi-Building Configuration (Class B/Style 4):

RUI	Page 38
Analog Audio	Page 39
Enhanced Analog Audio	Page 40
Digital Audio	Page 41

**Figure A-7. Internal Building or Multi-Building Configuration Class B/Style 4**

---

# Appendix – Sample Configurations, *Continued*

RUI  
 (Excluding 4120  
 Network)  
 Class B/Style 4

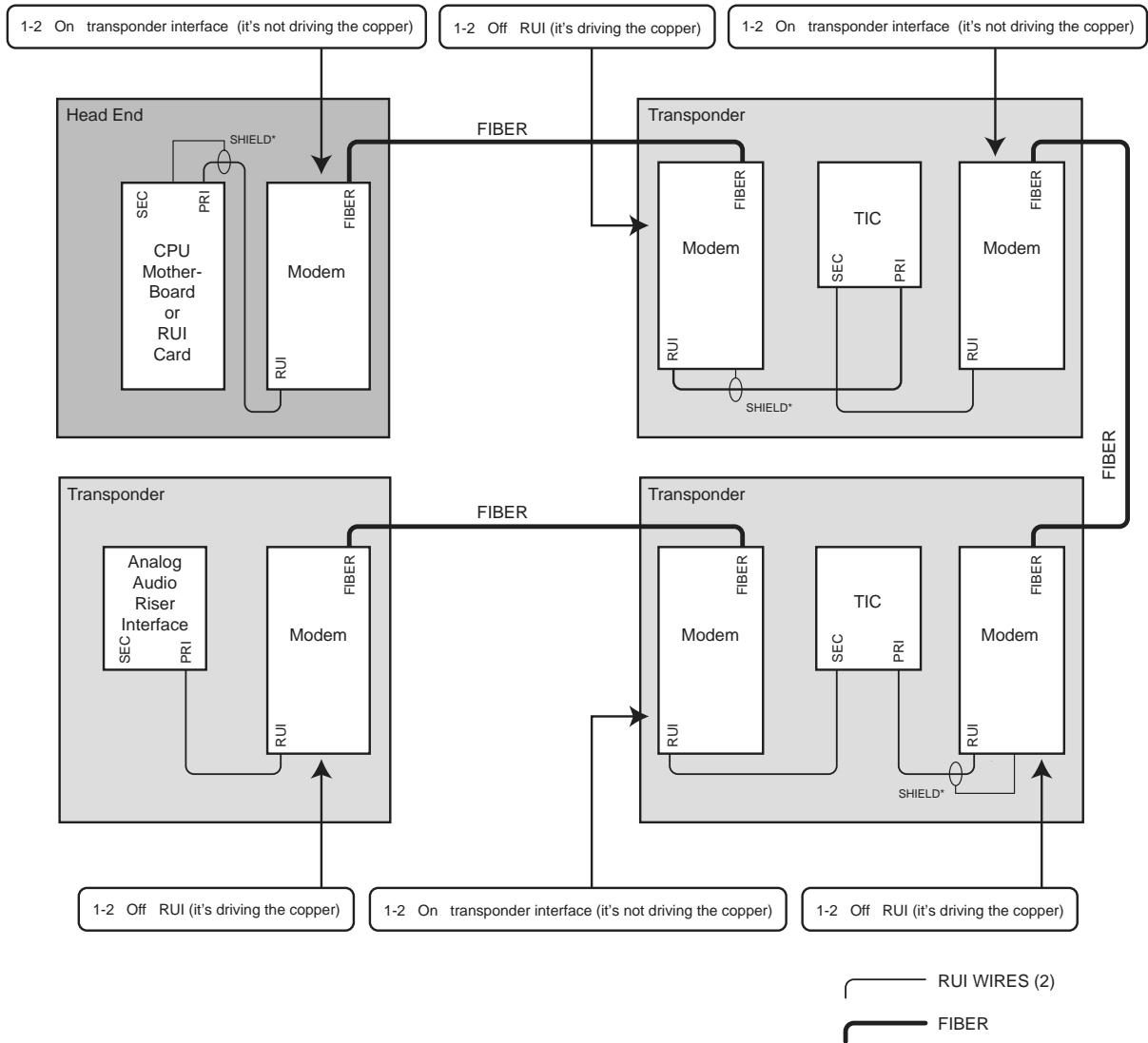

**Settings for all modems in this configuration:**

- SW1-1 is OFF (set for Class B wiring).
- SW1-3 is OFF (set as generic - all modems are generic in Class B configurations).
- SW1-4 is OFF (it is ignored since the modems are generic).
- SW1-5 is ON (enable RUI interface).

\*Shields are to be connected at one end of each wiring link to either Earth or 24C, as required. Ferrite beads must be installed at the point where copper wiring exits the system box.  
 Note: All switches not listed are set according to the application of their respective interface.

**Figure A-8. RUI Class B/Style 4**

# Appendix – Sample Configurations, *Continued*

## Analog Audio Class B/Style 4

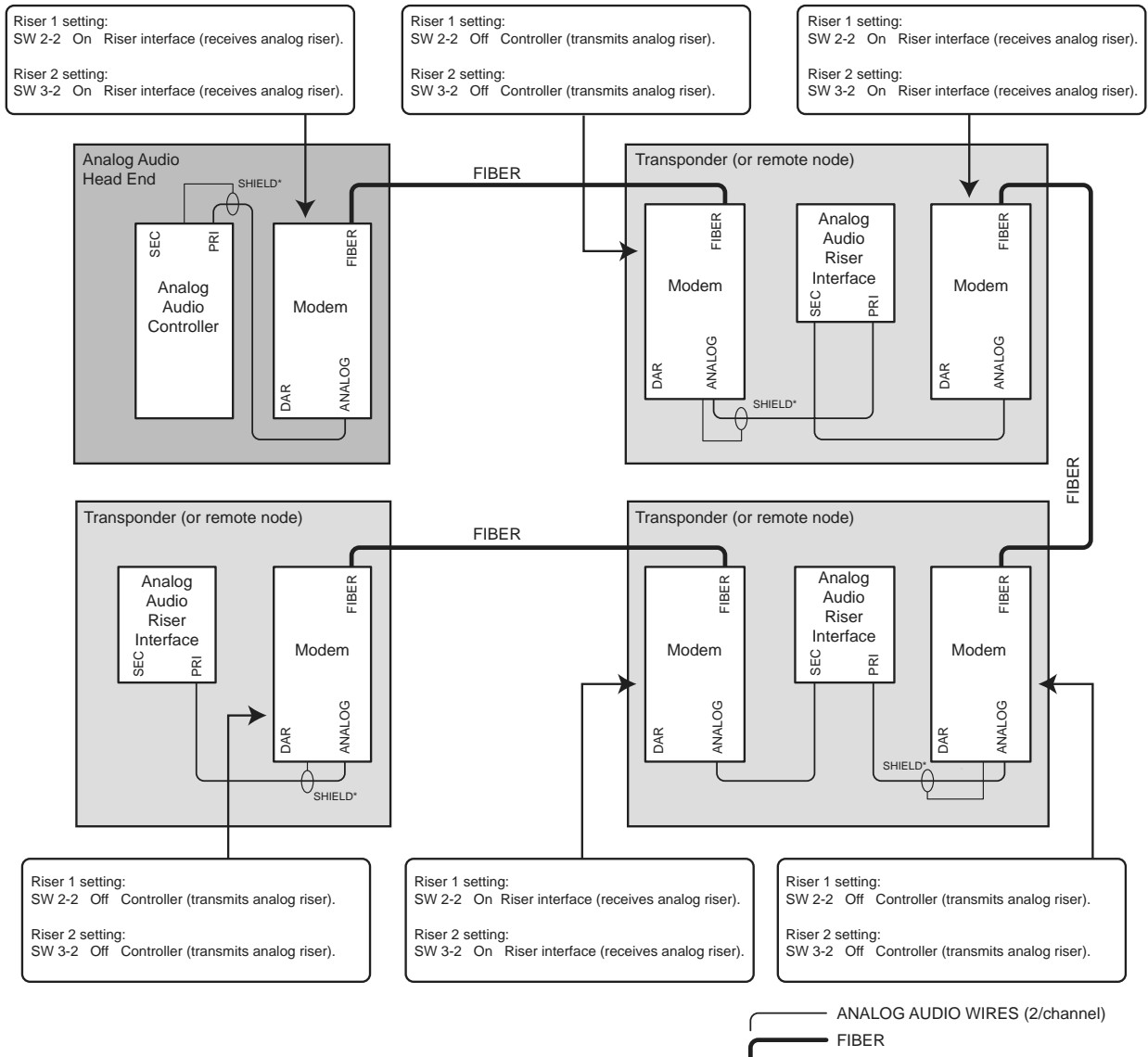

**Settings for all modems in this configuration:**

- SW2-1 and 3-1 are OFF (set for Class B wiring).
- SW2-3 and 3-3 are OFF (set as generic - all modems are generic in Class B configurations).
- SW2-4 and 3-4 are OFF (these are ignored since the modems are generic).
- SW2-5 and 3-5 are ON (enable CH1 & CH2 interface).

\*Shields are to be connected at one end of each wiring link to either Earth or 24C, as required.

Ferrite beads must be installed at the point where copper wiring exits the system box.

Note: All switches not listed are set according to the application of their respective interface.

**Figure A-9. Analog Audio Class B/Style 4**

# Appendix – Sample Configurations, *Continued*

## Enhanced Analog Audio (EAA) (limited to Channel 1 & excluding Digital Audio) Class B/Style 4

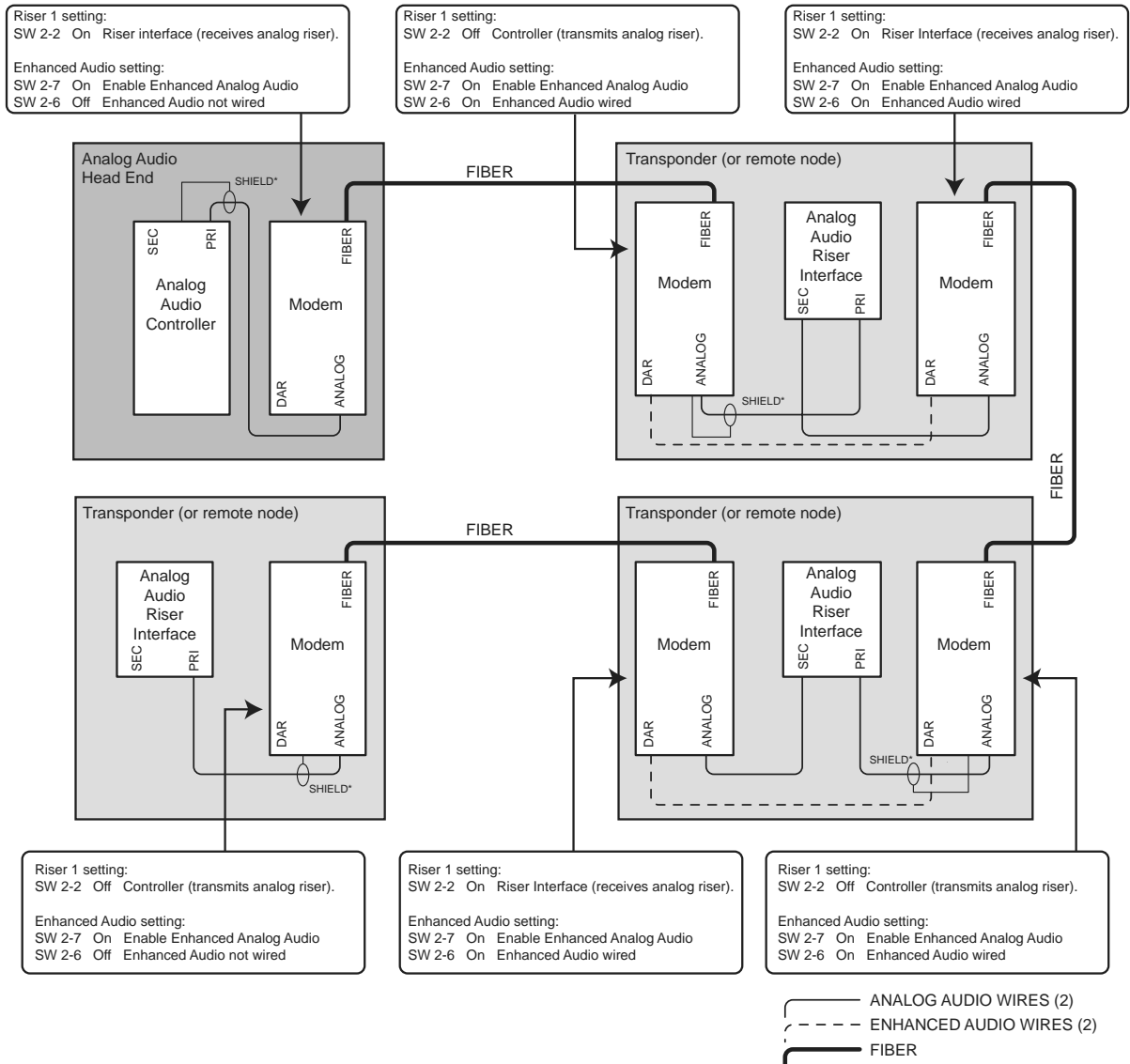

### Settings for all modems in this configuration:

- SW2-1 is OFF (set for Class B wiring).
- SW2-3 is OFF (set as generic - all modems are generic in Class B configurations).
- SW2-4 is OFF (these are ignored since the modems are generic).
- SW2-5 is ON (enable CH1 interface).

\*Shields are to be connected at one end of each wiring link to either Earth or 24C, as required. Ferrite beads must be installed at the point where copper wiring exits the system box.  
 Note: All switches not listed are set according to the application of their respective interface.

**Figure A-10. Enhanced Analog Audio (EAA) Class B/Style 4**

## Appendix – Sample Configurations, *Continued*

### Digital Audio (excluding Analog Audio Channel 1) Class B/Style 4

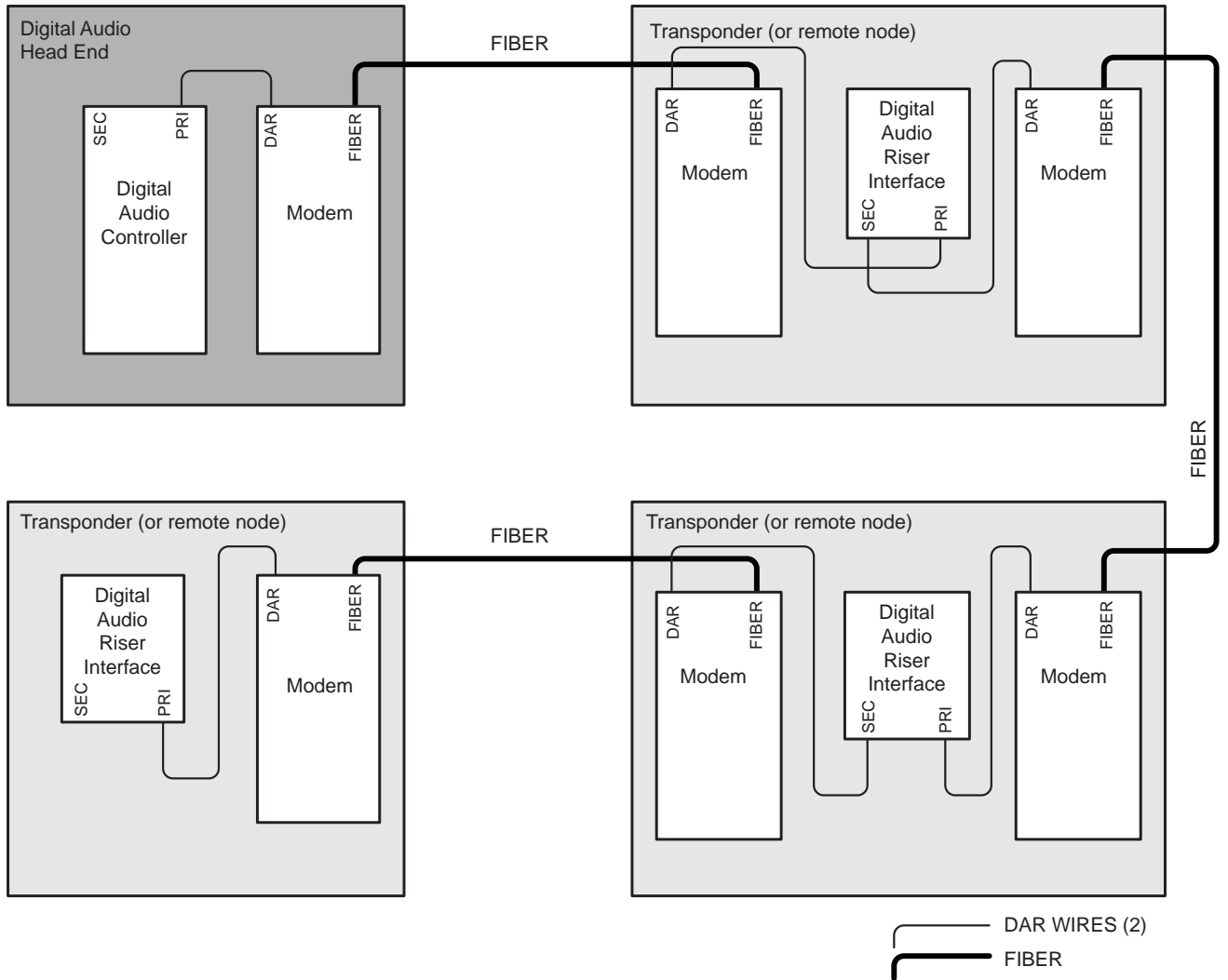

**Settings for all switches in this configuration:**

Switch 2-8 (DAR Enable) ON for all modems in this configuration.

Note: All switches not listed are set according to the application of their respective interface.

**Figure A-11. Digital Audio (excluding Analog Audio Channel 1) Class B/Style 4**

## Appendix – Sample Configurations, *Continued*

### Hub Configuration Overview

A Hub Configuration consists of a Main Loop with Nodes connected in a radial manner. In this configuration, the Modem connects the Hub Node to the Remote Nodes.

Hub Configurations for 4120 Network, Analog Audio, and Digital Audio are illustrated on the pages that follow.

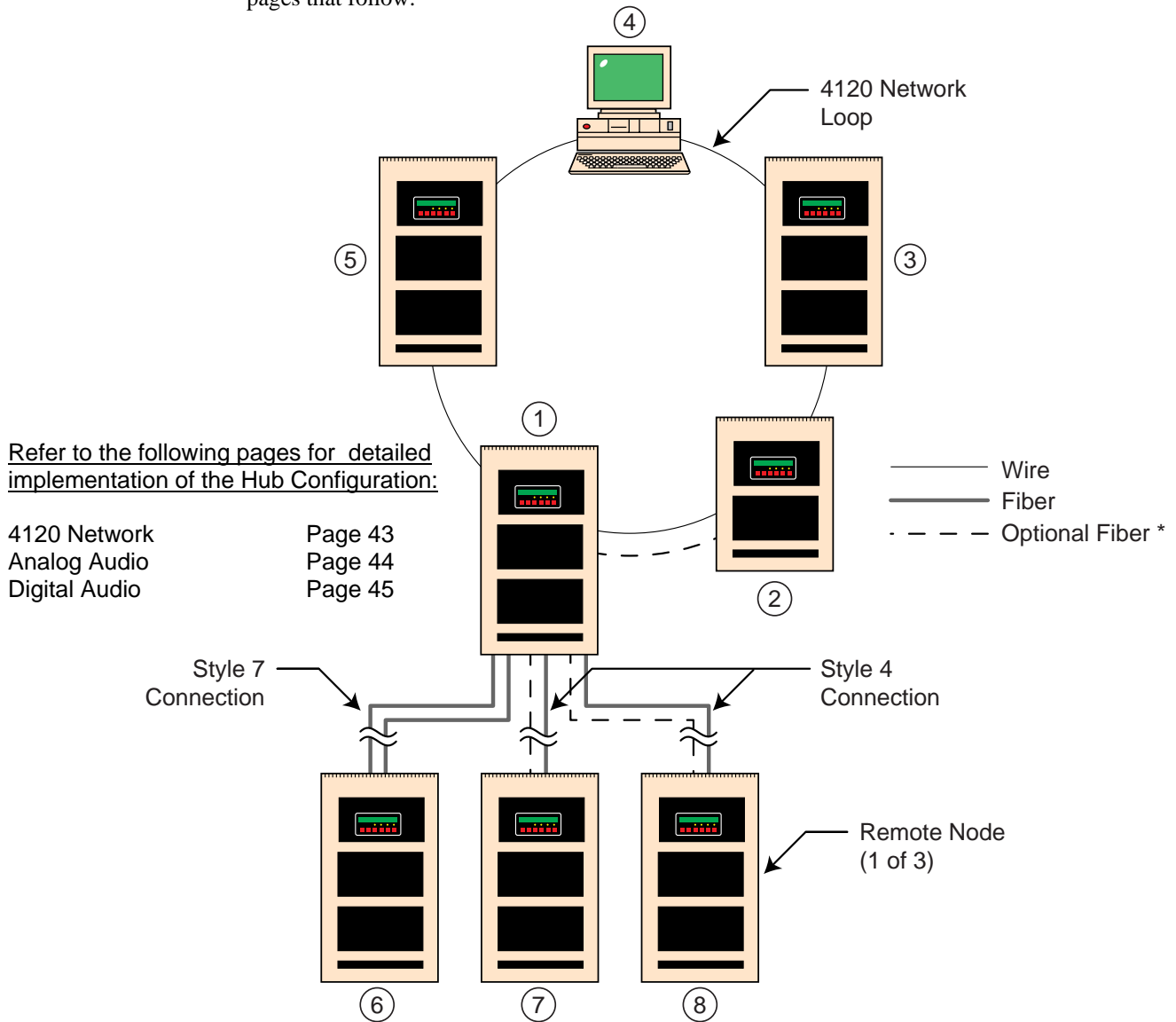

\*Required if analog audio interface is used. In digital audio systems, this fiber is only required if multiple T-tapped nodes are wired from a single node (as is shown here in that 3 nodes connect to Node 1).

Figure A-12. Hub Configuration



# Appendix – Sample Configurations, *Continued*

## Hub Configuration – 4120 Network

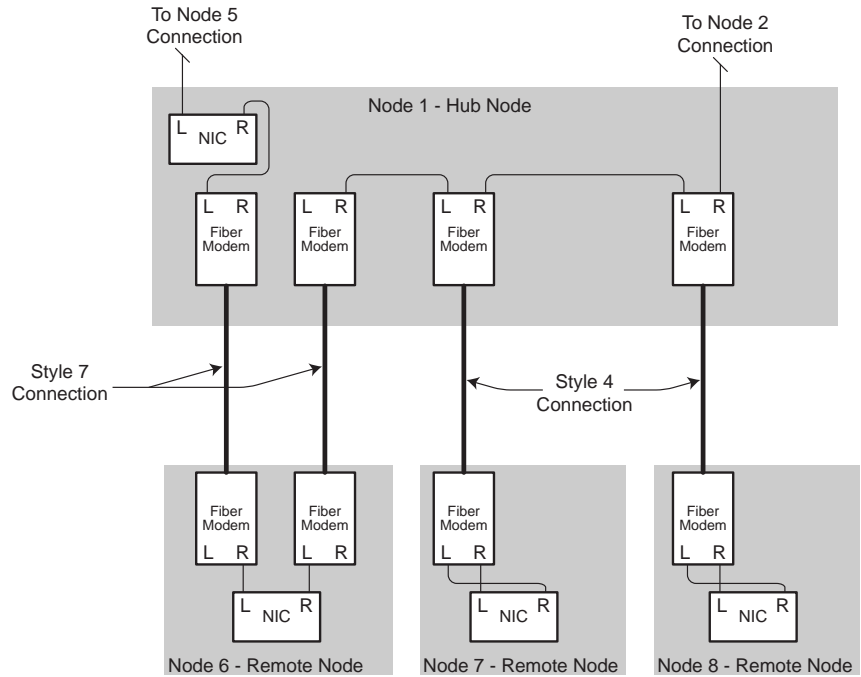

OR

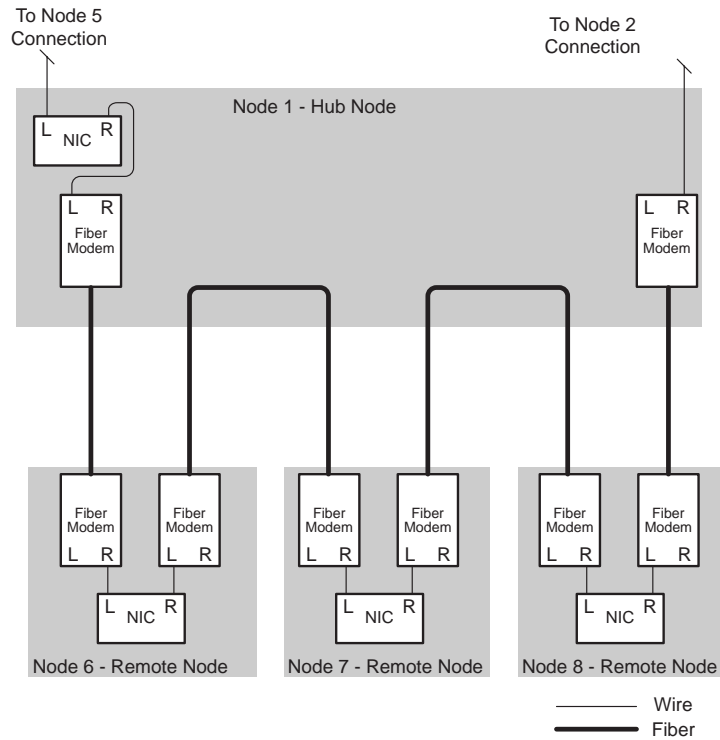

— Wire  
 — Fiber

### Settings for all modems in this configuration:

SW1-5 must be OFF.  
 SW1-6 (Network Protocol) must be set the same for all modems in this configuration.  
 SW1-7 (Network Baud Rate) must be set the same for all modems in this configuration.

Note: All switches not listed are set according to the application of their respective interface.

Refer to Figure 4 for shield connections.

Style 7 Connections

Figure A-13. Hub Configuration – 4120 Network

## Appendix – Sample Configurations, *Continued*

### Hub Configuration – Analog Audio

In this diagram, the head-end audio cabinet is not shown. If Class A is required, head and tail-end modems require x-link connections.

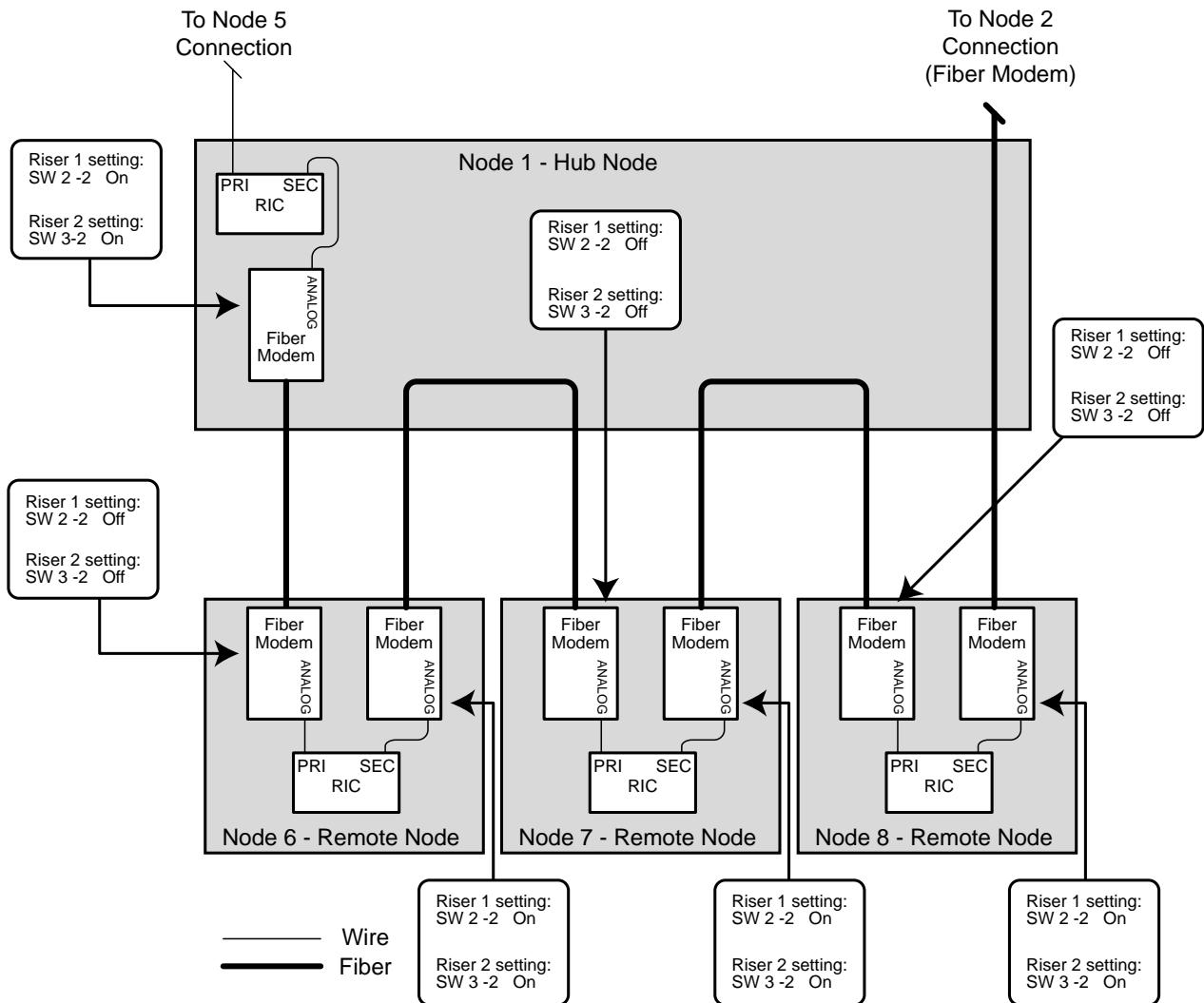

#### Settings for all modems in this configuration (assuming both channels in use):

- SW2-1 and 3-1 are ON (set for Class A wiring).
- SW2-3 and 3-3 are OFF (set as generic - all modems shown are generic).
- SW2-4 and 3-4 are OFF (these are ignored since the modems are generic).
- SW2-5 and 3-5 are ON (enable CH1 & CH2 interface).

#### Notes:

- RIC: Analog Audio Riser Interface Card.
- SW2-2 is ON for modems that receive the analog riser.
- SW2-2 is OFF for modems that transmit the analog riser.
- Shields are to be connected at one end of each wiring link to either Earth or 24C as required.
- All switches not listed are set according to the application of their respective interface.

**Figure A-14. Hub Configuration – Analog Audio**

# Appendix – Sample Configurations, *Continued*

## Hub Configuration – Digital Audio

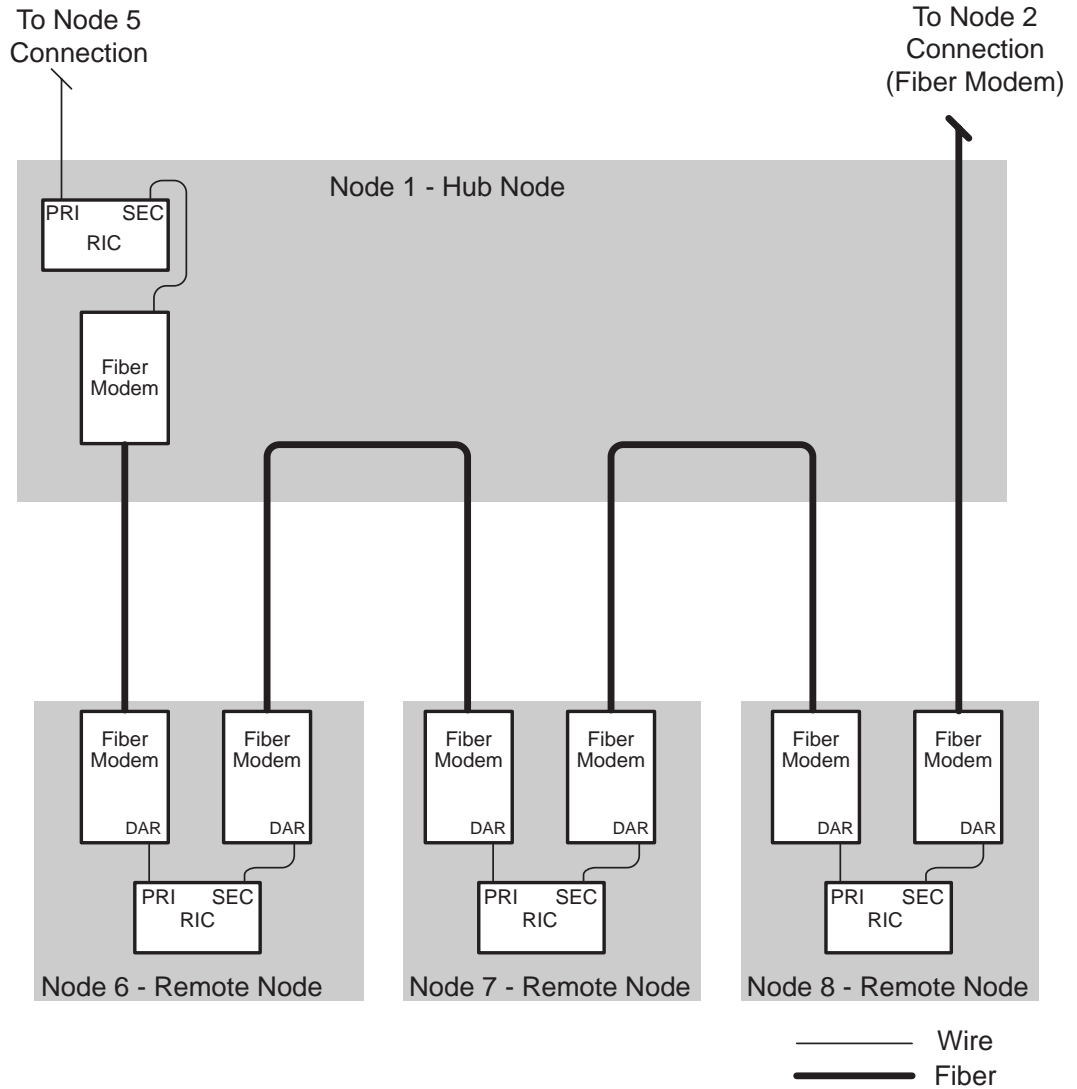

RIC: Digital Audio Riser Interface Card.  
 SW2-8: ON (enable DAR interface).

**Figure A-15. Hub Configuration – Digital Audio**

# Appendix – Sample Configurations, *Continued*

## Interconnected Loop and Star Configurations – Overview

In this configuration, the Fiber Modem connects the two Style 7 network loops (#1 & #2) in tandem. It also connects several remote nodes to the loop (star).

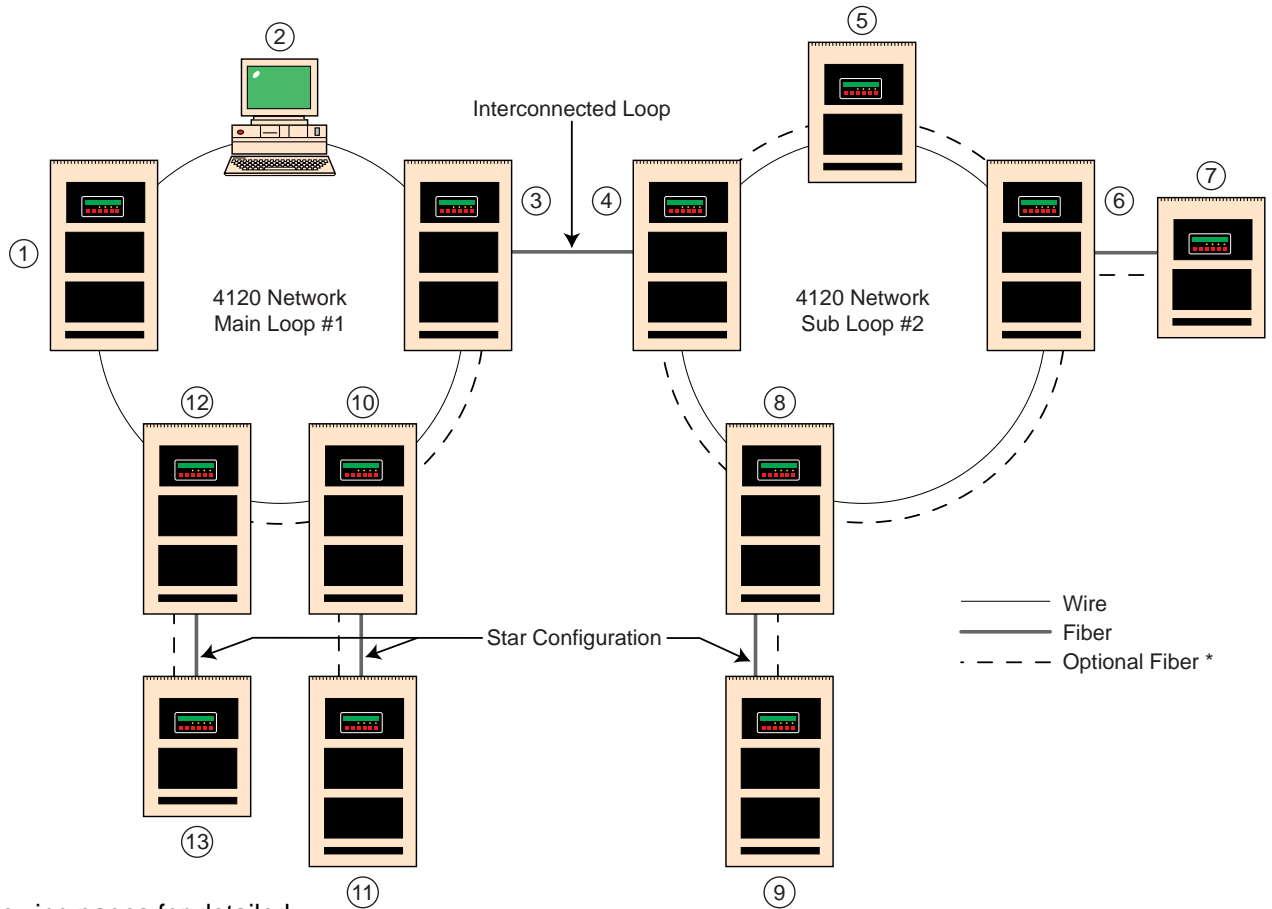

Refer to the following pages for detailed implementation of the Interconnected Loop and Star Configuration:

4120 Network	Page 47
Analog Audio	Page 48
Digital Audio	Page 49

\*Required if analog audio interface is used. In digital audio systems, this fiber is only required if multiple T-tapped nodes are wired from a single node.

Figure A-16. Interconnected Loop and Star Configurations

## Appendix – Sample Configurations, *Continued*

### Interconnected Loop and Star Configurations – 4120 Network

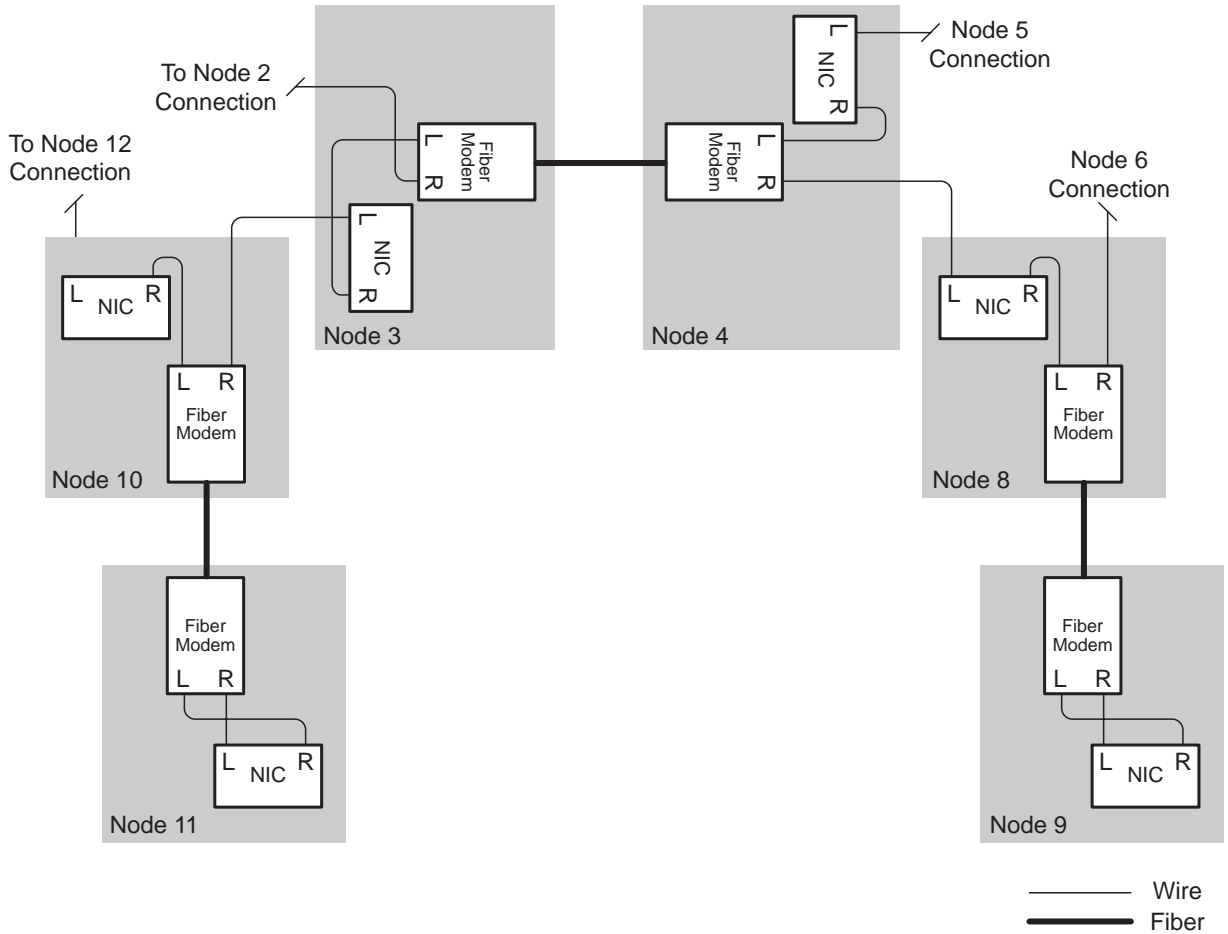

#### Settings for all modems in this configuration:

SW1-5 must be OFF (enable network).

SW1-6 (Network Protocol) must be set the same for all modems in this configuration

SW1-7 (Network Baud Rate) must be set the same for all modems in this configuration

Note: All switches not listed are set according to the application of their respective interface.

Refer to Figure 4 for shield connections.

**Figure A-17. Interconnected Loop and Star Configurations – 4120 Network**

## Appendix – Sample Configurations, *Continued*

### Interconnected Loop and Star Configurations – Analog Audio

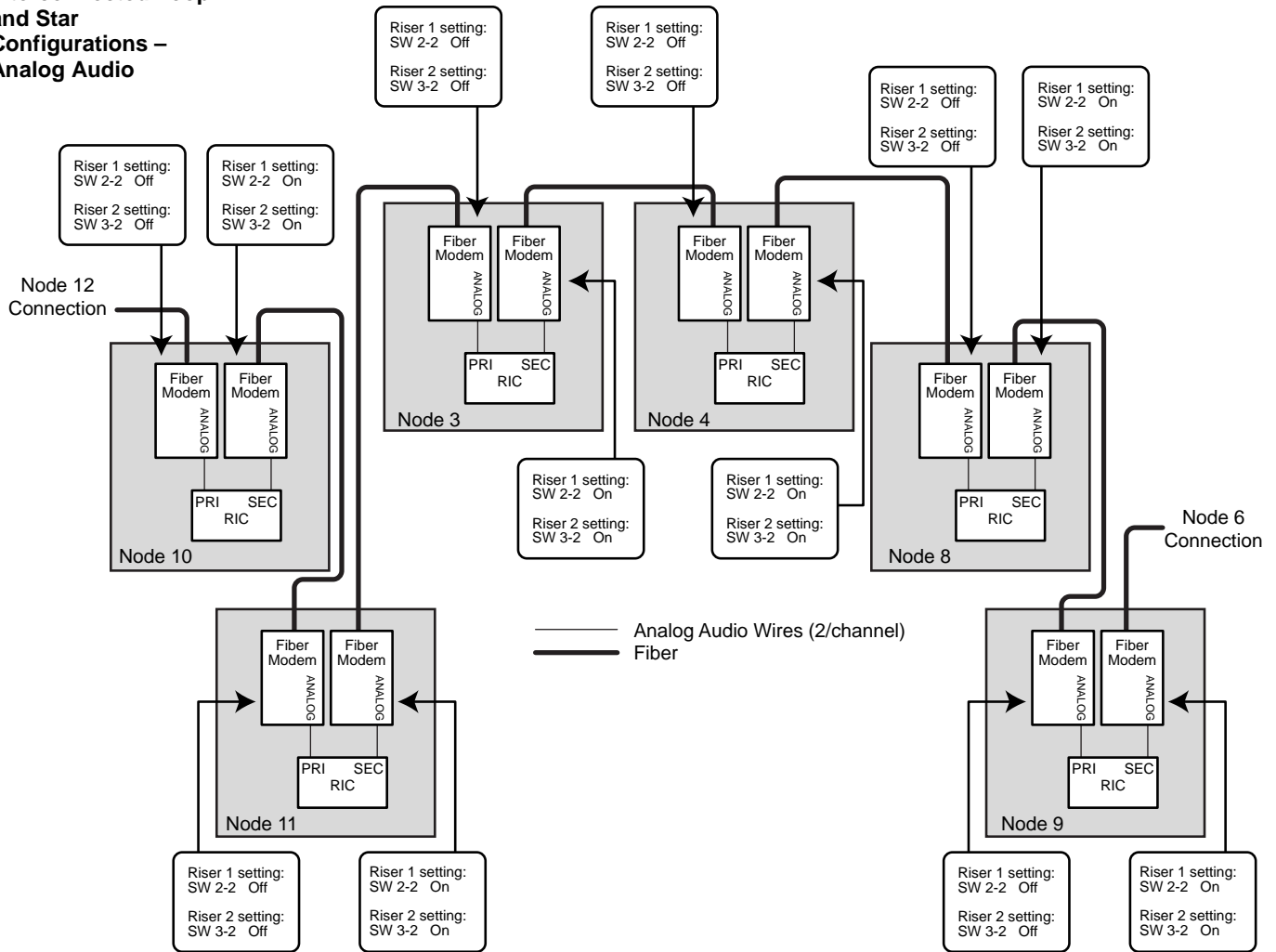

#### Settings for all modems in this configuration (assuming both channels in use):

- SW2-1 and 3-1 are OFF (set for Class B wiring).
- SW2-3 and 3-3 are OFF (set as generic - all modems shown are generic in Class B configuration).
- SW2-4 and 3-4 are OFF (these are ignored since the modems are generic).
- SW2-5 and 3-5 are ON (enable CH1 & CH2 interface).

#### Notes:

- RIC: Analog Audio Riser Interface Card.
- SW2-2 and SW3-2 are ON for modems that receive the analog riser.
- SW2-2 and SW3-2 are OFF for modems that transmit the analog riser.
- Shields are to be connected at one end of each wiring link to either Earth or 24C as required.
- All switches not listed are set according to the application of their respective interface.

Figure A-18. Interconnected Loop and Star Configurations – Analog Audio

## Appendix – Sample Configurations, *Continued*

### Interconnected Loop and Star Configurations – Digital Audio

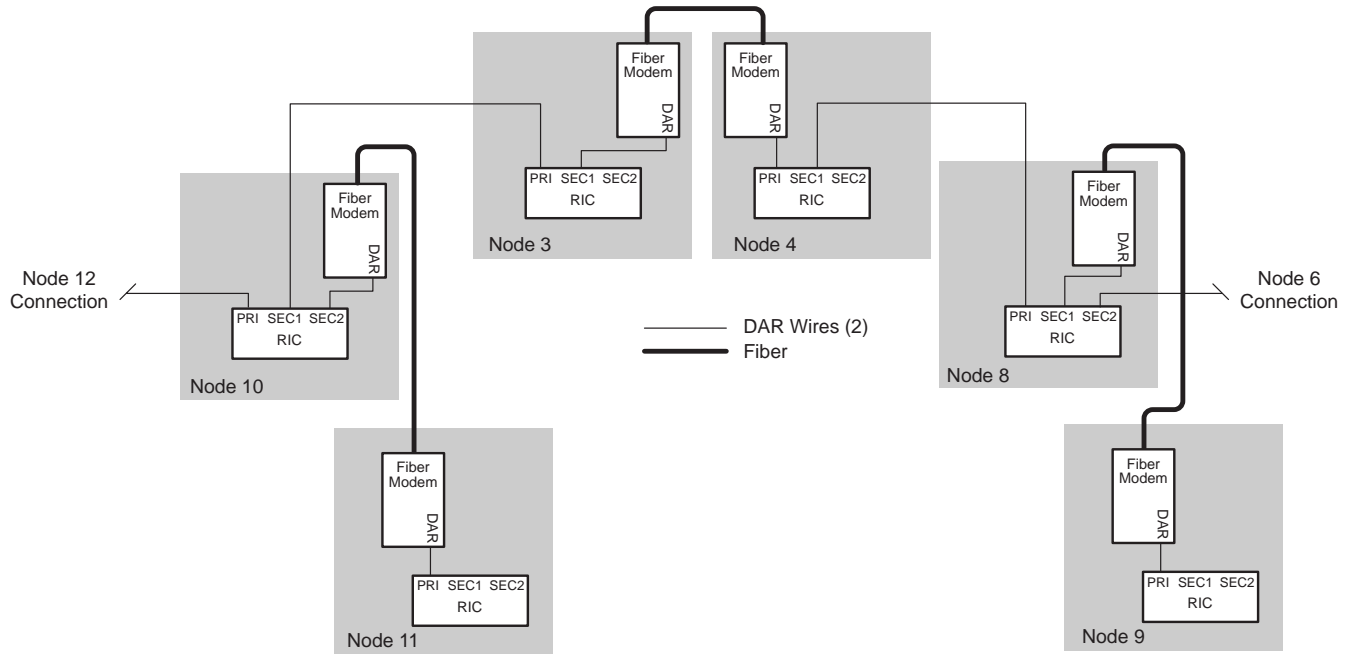

**Settings for all modems in this configuration:**  
SW2-8 is ON for all modems in this example (enable DAR).

Notes:

RIC: Digital Audio Riser Interface Card.

All switches not listed are set according to the application of their respective interface.

**Figure A-19. Interconnected Loop and Star Configurations – Digital Audio**

## Appendix – Sample Configurations, *Continued*

### TrueSite Workstation (TSW)

The illustration below shows how to connect the 4120 Network to IMS with fiber only. Node 1 is used for power and an enclosure is used for the Modems.

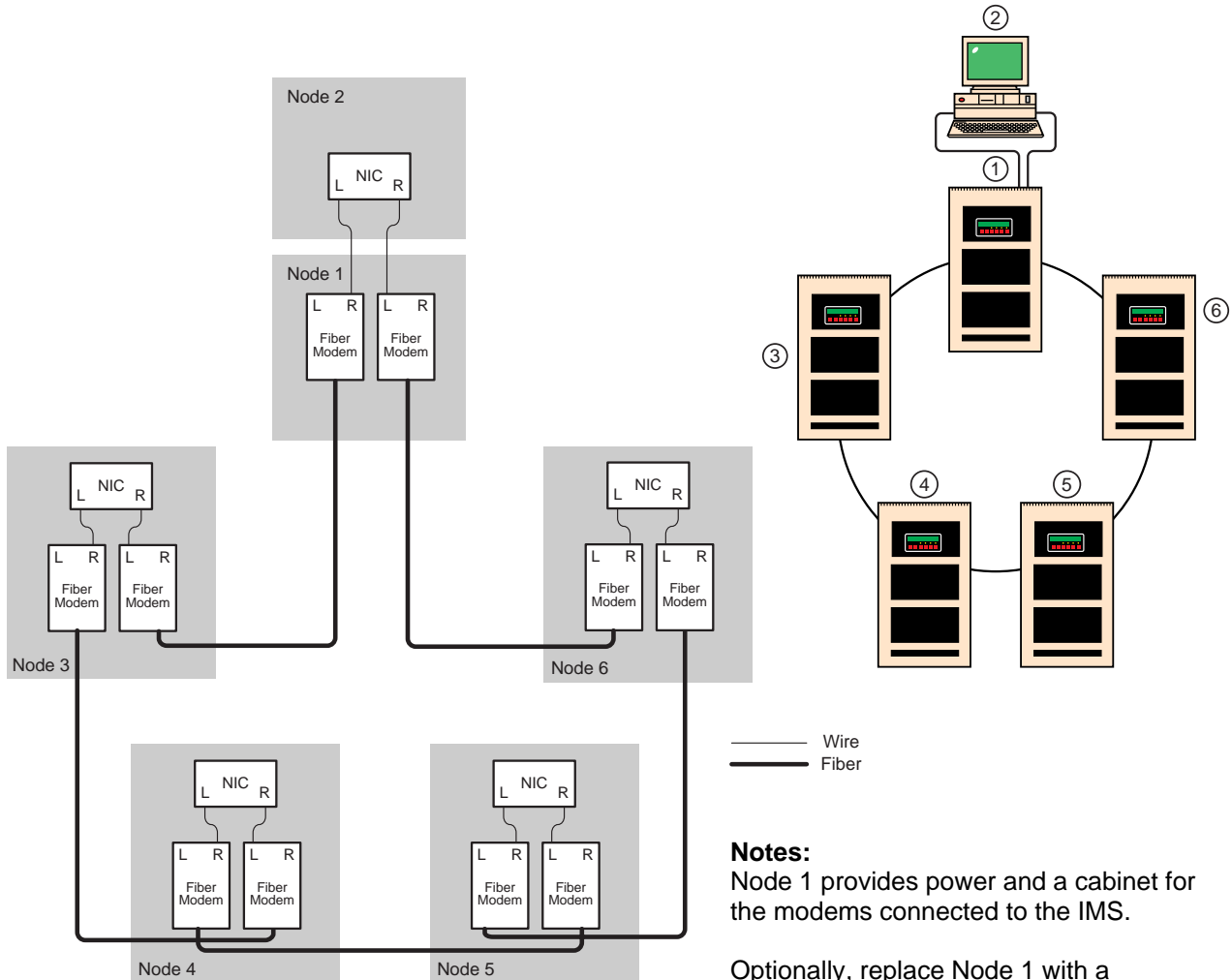

#### Settings for all modems in this configuration:

SW1-5 must be OFF.

SW1-6 (Network Protocol) must be set the same for all modems in this configuration

SW1-7 (Network Baud Rate) must be set the same for all modems in this configuration

Note: All switches not listed are set according to the application of their respective interface.

Refer to Figure 4 for shield connections.

#### Notes:

Node 1 provides power and a cabinet for the modems connected to the IMS.

Optionally, replace Node 1 with a transponder cabinet and connect additional modems to wire RUI to the transponder.

**Figure A-20. Fiber-Connected IMS Configuration**



# Appendix – Sample Configurations, Continued

## Fiber Modem Audio Expansion Board Class A/Style 6

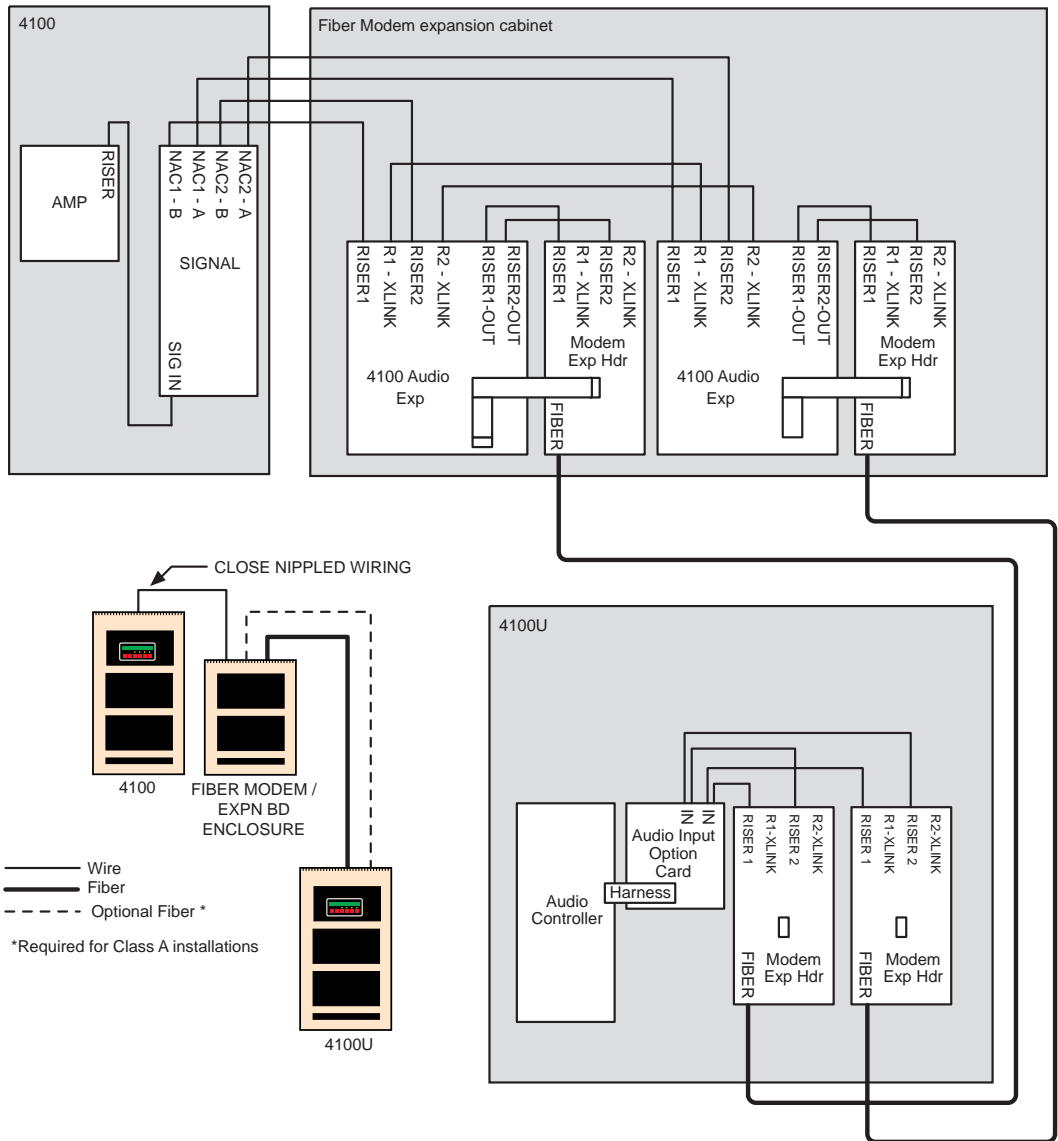

Figure A-21. Fiber Modem Audio Expansion Board, Class A/Style 6 (4100U Shown)

# Appendix – Sample Configurations, *Continued*

## Fiber Modem Audio Expansion Board Class B/Style 4

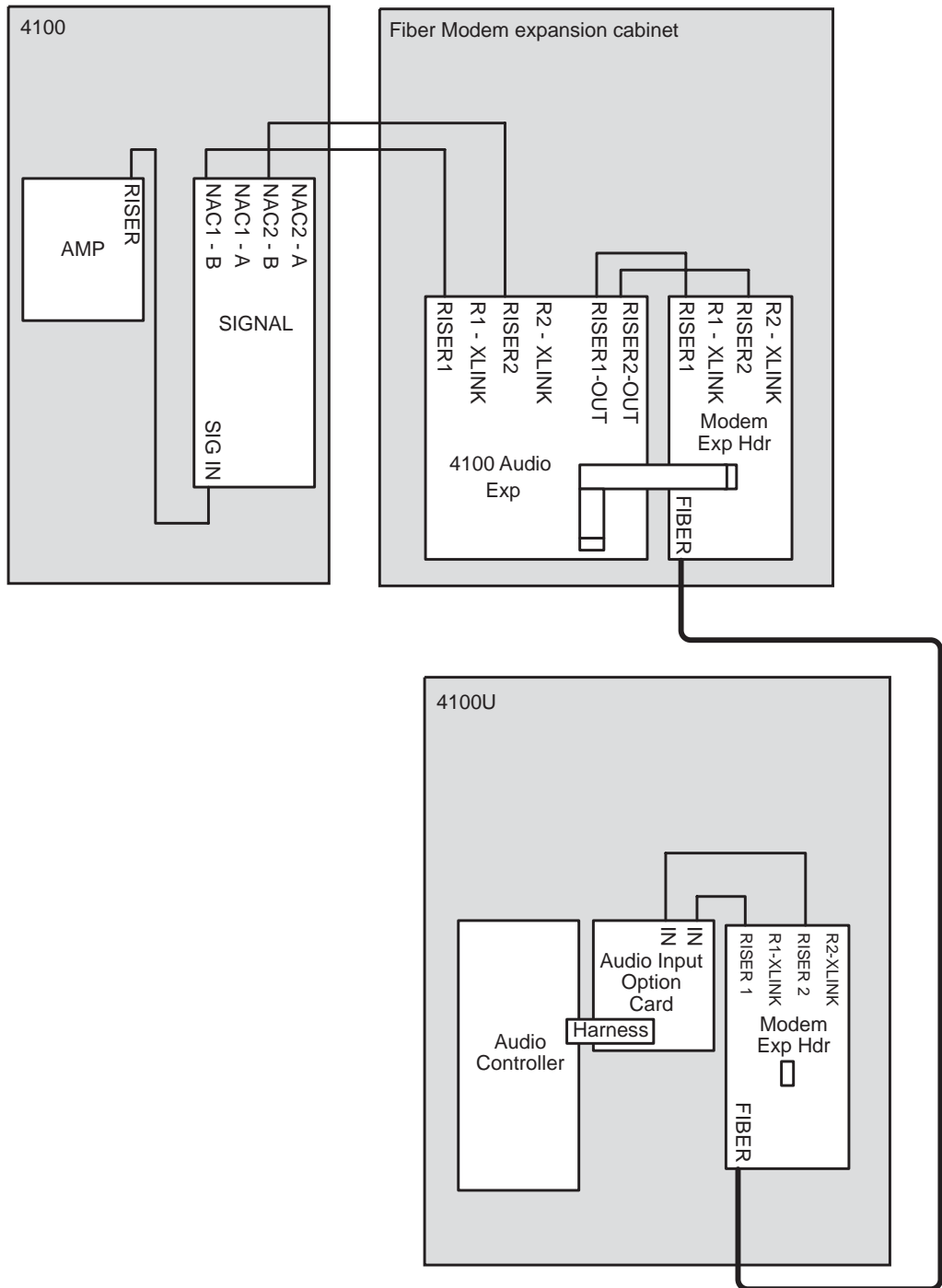

Figure A-22. Fiber Modem Audio Expansion Board, Class B/Style 4 (4100U Shown)



579-831  
Rev. F



FIRE • SECURITY • COMMUNICATIONS • WORLDWIDE SALES & SERVICE