



**TECHNICAL DATA**

**MODEL EG-100  
ESFR SPRINKLER GUARD**

The Viking Corporation, 210 N Industrial Park Drive, Hastings MI 49058  
 Telephone: 269-945-9501 Technical Services: 877-384-5464 Fax: 269-818-1680 Email: techsvcs@vikingcorp.com  
 Visit the Viking website for the latest edition of this technical data page [www.vikinggroupinc.com](http://www.vikinggroupinc.com)

**1. DESCRIPTION**

Viking ESFR Sprinkler Guards are used in conjunction with ESFR style sprinklers where allowed by the approvals. (Refer to the Approval Charts) The guards are hard-wire cages designed to encase the sprinklers and protect them from mechanical damage. They are recommended for areas where sprinklers are installed at a low elevation and/or near a high degree of human or mechanical activity.

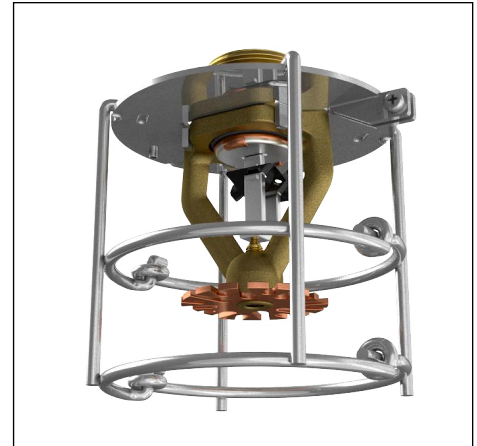

**2. LISTINGS AND APPROVALS**



**FM Approved: Class 2091**

Approved for use with the following sprinklers: VK506, VK510, and VK514

**3. TECHNICAL DATA**

**Material Standards:**

**Guard (flat steel):** Carbon Steel SPCC-CD, Per JIS G34141

**Guard (wire):** Q235 Cold Drawn Steel Wire, Per GB/T 700

**Screw:** 6-32 x 3/8 (R.H. Phillips-Slotted Combination Drive): Steel

**Screw Finish:** Zinc Plate

**Rivet:** Steel Carbon Steel, Per AISI 12L14

**Ordering Information:**

TABLE 1: ORDERING INFORMATION AND DIMENSIONS		
Part Number	Description	Size
		NPT
23334F	Guard, ESFR, Chrome	1"
23334M/R	Guard, ESFR, Painted (red)	1"

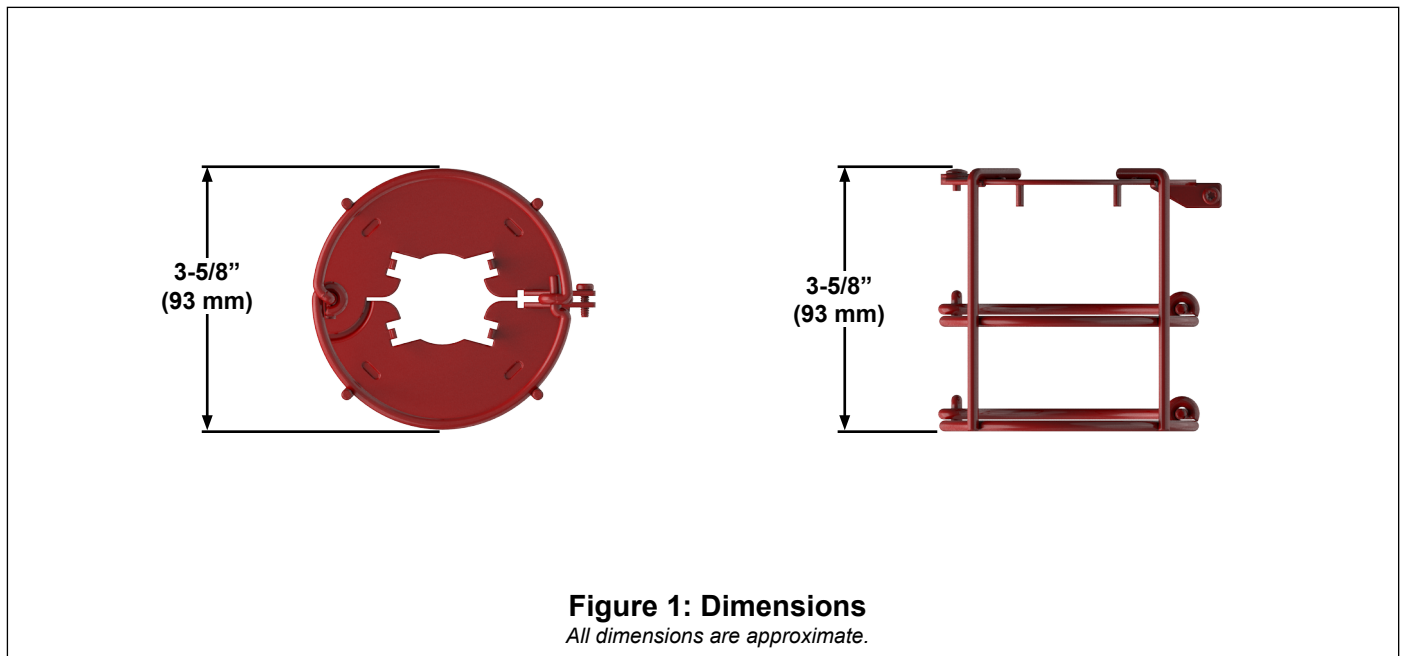
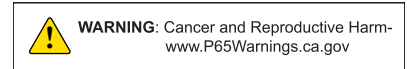



## TECHNICAL DATA

## MODEL EG-100 ESFR SPRINKLER GUARD

The Viking Corporation, 210 N Industrial Park Drive, Hastings MI 49058

Telephone: 269-945-9501 Technical Services: 877-384-5464 Fax: 269-818-1680 Email: techsvcs@vikingcorp.com

Visit the Viking website for the latest edition of this technical data page [www.vikinggroupinc.com](http://www.vikinggroupinc.com)

### 4. INSTALLATION

#### NOTICE

Improper installation can impede the sprinkler operation.

► Follow the procedures in this document to properly install the sprinkler guard.

#### Installing the ESFR Sprinkler Guard on the Sprinkler

Tool needed:

#2 R.H. Phillips or Flat Head screwdriver (not available from Viking.)

Procedure:

1. Loosen the screw and open the guard.
2. Place the guard around the sprinkler as shown. Be sure the tabs line up with the sprinkler frame as shown.
3. Close the guard and tighten the screw.

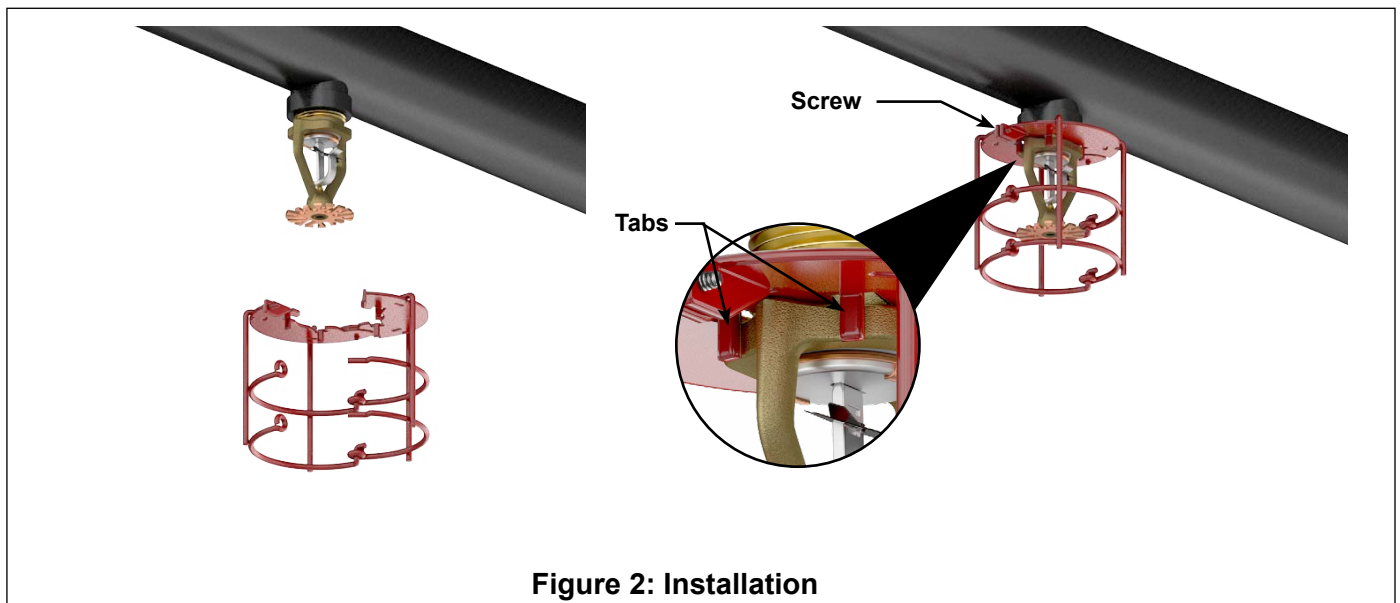

**Figure 2: Installation**

### 5. OPERATION

Refer to the sprinkler technical data page for the sprinkler model used. The ESFR Sprinkler Guard is a hard-wire cage designed to encase the sprinkler and protect it from mechanical damage.

### 6. INSPECTIONS, TESTS, AND MAINTENANCE

Refer to NFPA 25 for Inspection, Testing and Maintenance requirements.

### 7. AVAILABILITY

Viking ESFR Sprinkler Guards are available through a network of domestic and international distributors. See the Viking website for the closest distributor or contact Viking.

### 8. GUARANTEE

For details of warranty, refer to the current list price schedule or contact us directly.