

# E3 Series® Broadband System

Intelligent, Networked, Multi-Channel Fire Alarm Control and Emergency Voice Evacuation System

## General

The Gamewell-FCI, E3 Series® Broadband System is a modular design and offers a wide range of configurations from two basic sub-assemblies. These sub-assemblies form an integrated, distributed fire alarm system that includes audio evacuation and fire command capability.

The network communication transmits all fire alarm, audio evacuation, voice paging, and fire fighter communications. This System can be used as a component of the following E3 Series Systems:

- E3 Series Broadband Voice Evacuation System
- E3 Series Combined Fire and Mass Notification System

The E3 Series Broadband System is a revolutionary advance in fire detection and emergency voice evacuation system design. E3 Series Broadband employs proven technology and expands it to accomplish emergency multi-channel voice evacuation, two-way fire fighter communications, and building control applications, while simultaneously sent over a single pair of wires or fiber-optic cable.

It is a true peer-to-peer, token ring passing, networked system capable of supporting up to 64 individual nodes. In addition, the Addressable Node Expander (ANX) board expands the network to 122 nodes. All system status, control-by-event sequences, audio voice paging, and fire fighter telephone signals are sent between nodes over a single pair of wires or fiber-optic cable.

Each E3 Series Broadband node can be spaced along the network a maximum distance of 3,000 feet (914.4 m) over an unshielded, twisted-pair of wires or fiber-optic cable with signal loss up to 8dB loss. Built-in isolation at each node permits Style 4, 6, and 7 network configurations.

The E3 Series Broadband is simple to configure for any project requirement. A complete E3 Series Broadband application can be assembled from the following types of nodes:

- ILI-E3/ILI95-E3 Series • ANX • INCC Command Center • INX Transponder



E3 Series Broadband

## FEATURES & BENEFITS

- IBC Seismic Certified.
- Listed under UL® Standard 864, 9th Edition
- Listed under UL Standard UL2572 for Mass Notification
- UL Listed for smoke control (dedicated and non-dedicated) when properly configured.
- FM/UL Listed for Pre-action/Deluge use
- All communication signals and control-by-event sequences over a single pair of twisted, unshielded wires or fiber-optic cable
- Distributed architecture, including Style 7 wiring configurations, allow system components to continue normal operation with no loss of function during single line fault conditions
- Integrates INX transponders and INCC command centers to create a complete audio evacuation system with up to 122 nodes
- Redundant command centers with microphone and fire fighter's handset are easily configured by adding INCCs
- Uses state-of-the-art digital signal processor (DSP) technology for efficient audio compression and filtering
- Provides up to 150 watts of audio power from 3 AM-50 Series amplifiers with an additional 50 watts of standby power in each Intelligent Network Transponder (INX)

## General

The E3 Series Broadband System is capable of the most sophisticated sequences of operations. The Field Configuration Program (FCP) is based on Boolean logic statements providing AND, OR, NOT, and XOR logic operators. These operators can be combined to produce additional Boolean operators such as NAND, NOR, XNOR. The E3 Series Broadband is software-programmable for multi-channel digital audio applications. It is ideal for use with a wide range of complex system applications including high-rise or campus installations. An array of cabinets allows for neat, compact, installations.

A comprehensive set of timing functions can be attached to any input/output logic statement for the staggered reset of fan control relays, time-delayed alarm activation, automatic. The E3 Series control panel is a microprocessor-based fire alarm control panel that uses the following:

- ILI-E3/ILI95-E3 Series, Intelligent Loop Module or
- ANX with two signaling line circuits
- Two notification appliance circuits

When the E3 Series control panel transmits to remote locations, the optional RPT-E3 provides the ILI-E3/ILI95-E3 Series or the ANX with signal boosting and transient protection, as well as connectivity for both wire and fiber-optic cables. Other options also include an integral Digital Alarm Communicator Transmitter (DACT) that supports most popular reporting formats.

## INCC (Intelligent Network Command Center)

The Intelligent Network Command Center (INCC) serves as the central point of interface between an operator and the system's audio evacuation, fire fighter intercom, and building network. The INCC occupies a single address on the E3 Series Broadband network. A typical INCC assembly consists of the following:

- Intelligent Network Interface-Voice Gateway (INI-VGC-Third Generation) or (INI-VGC-UTP-fiber-optic or unshielded twisted-pair) modules
- One or more Addressable Switch Modules (ASM-16)
- Optional Network Graphic Annunciator (NGA)
- Remote 48 LED driver module (ANU-48)

Other component options include a paging microphone and a fire fighter's handset that connects to the INI-VGC (Third Generation) or INI-VGC-UTP module. Each INI-VGC (Third Generation) or INI-VGC-UTP module can support up to 16 ASM-16 modules.

Each ASM-16 has 16 push-button switches for a maximum capacity of 256 switches per INI-VGC command center. Each switch has three associated LEDs, colored green, yellow, and red. These switches and their LEDs that are fully programmable to serve any system function desired. These switches and LEDs can control the following:

- audio speaker circuits
- addressable relay outputs
- notification appliance circuits
- fire fighter phone control circuits
- any other special application that might be required

Multiple INCCs can be configured into the E3 Series Broadband network to serve as a completely independent command center to operate either for the local area or to operate as remote command centers mimicking, in part or in whole, the function of a main command center.

## INX (Intelligent Network Transponder)

The Intelligent Network Transponder (INX) acts as a network audio transponder for the E3 Series Broadband Network. The INX transponder serves as the point of distribution for the system's audio and fire fighter telephone circuits and occupies a single node on the E3 Series Broadband network.

A typical INX assembly consists of the following components:

- ANX
- INI-VGX Module
- PM-9/PM-9G power supply
- Up to four AM-50 Series amplifiers
- ILI-MB-E3/ILI95-MB-E3
- ILI-S-E3/ILI95-S-E3

The INX transponder occupies a single address on the network and provides termination points for the network connection using either a pair of unshielded twisted-pair wire or fiber-optic cable.

The INX transponder receives its power from a PM-9/PM-9G, 9 ampere, filtered, switching power supply providing 24 VDC nominal operating voltage. The PM-9/PM-9G has an integral standby battery charger capable of recharging up to 55 A/H batteries. The E3BB-BB-BC/INX cabinet can house up to 18 A/H sized batteries.

## INI-VGX (Intelligent Network Interface-Voice Gateway)

The INI-VGX uses advanced Digital Signal Processing (DSP) technology for audio compression and filtering allowing the E3 Series Broadband to produce a superior audio tone while conserving network bandwidth to broadcast an instantaneous response. Background noise is automatically filtered during voice paging and fire fighter communications increasing audibility and eliminating the need for push-to-talk devices.

The INI-VGX can accommodate up to 16 different messages with a total combined duration of three minutes. Each message can be field installed via a

## INI-VGX (Intelligent Network Interface-Voice Gateway)

laptop computer and setup to broadcast a voice message or an evacuation tone.

The INI-VGX also provides a fire fighter phone riser and an addressable signaling line circuit that can connect to multiple phone jacks or warden stations through as many as 16 AOM-TELF modules. In addition, the INI-VGX SLC can support up to 32 speaker circuits using the AOM-2SF for single channel applications.

## AM-50 Series Amplifiers

The INX or INX CAB-B cabinet can contain up to four AM-50 Series amplifiers that produce 50 watts of power @ either 25  $V_{RMS}$  or 70.7  $V_{RMS}$  audio output.

Each amplifier includes two separate speaker circuits that can be wired Style Y (Class B) or Style Z (Class A). In addition, each amplifier can produce its own tone or message independently of other system amplifiers. Thus, an INX transponder can produce three audio channels simultaneously. Each INX transponder can support up to four AM-50 Series amplifiers operating as main amplifiers with one AM-50 Series amplifier used as a fail-safe backup amplifier.

Figure 1 illustrates the INCC Command Center and the INX Cabinet.

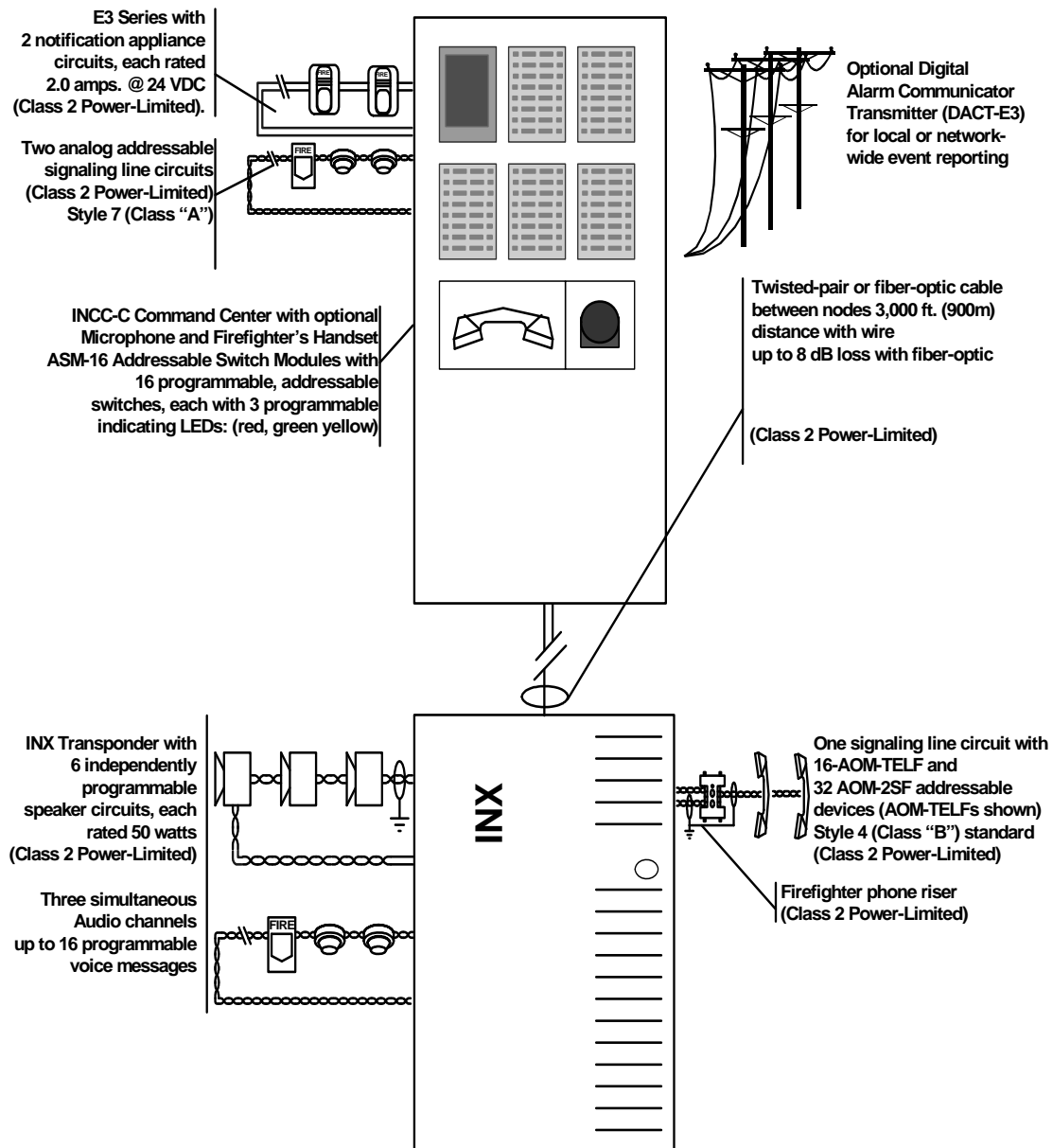

Figure 1 INCC Command Center and INX

Figure 2 illustrates the E3 Series Broadband System configuration.

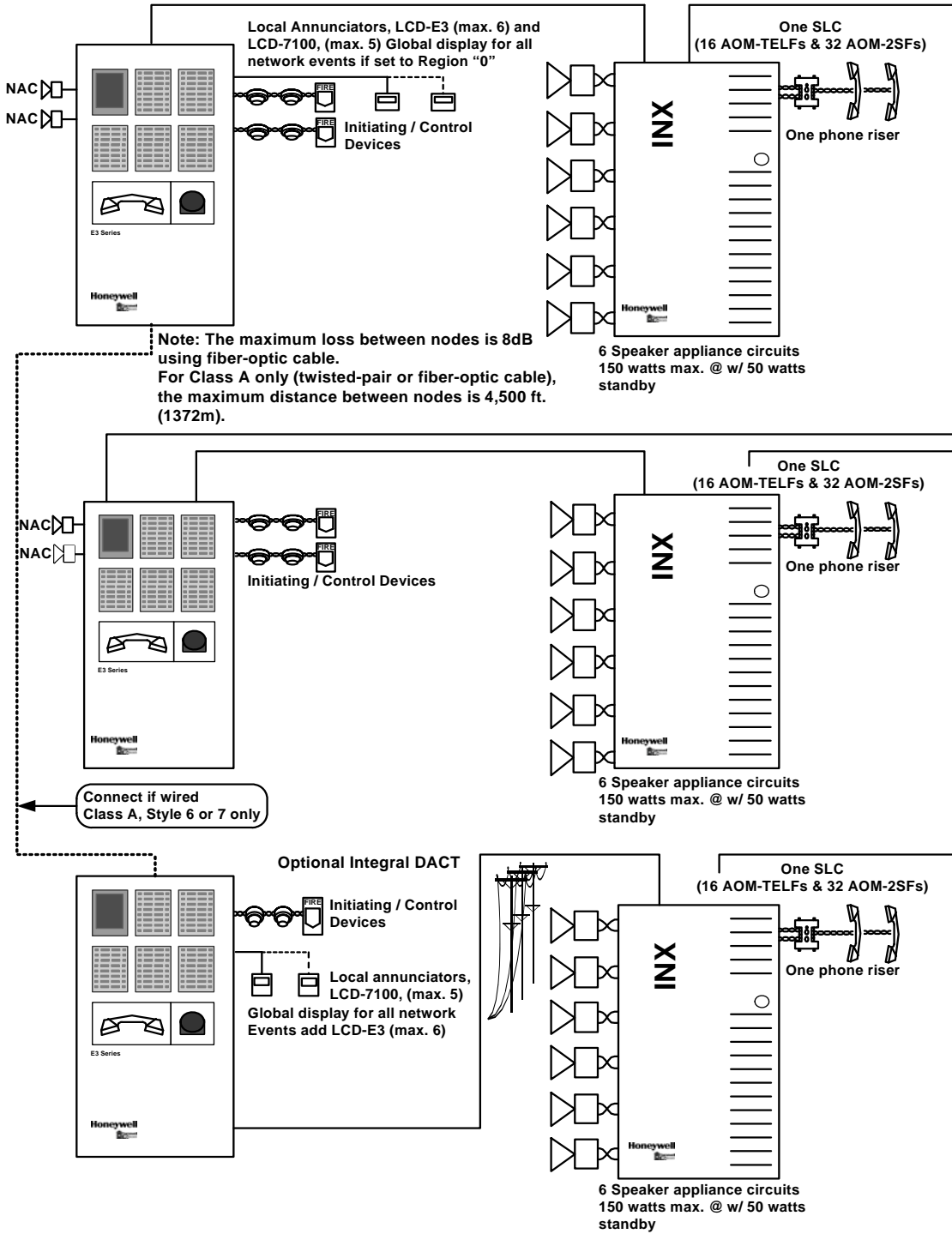

Figure 2 E3 Series Broadband System

**Ordering Information**

Part Number	Description
<b>E3 Series Control</b>	
ILI95-MB-E3	Intelligent Loop Interface95-Main Board
ILI-MB-E3	Intelligent Loop Interface-Main Board
ILI-S-E3	Intelligent Loop Interface-Expansion
ILI95-S-E3	Intelligent Loop Interface95-Expansion
ANX-SR	Addressable Node Expander-Single Ring
ANX-MR-FO	Addressable Node Expander-Multi-Ring Twisted-Pair
ANX-MR-UTP	Addressable Node Expander-Multi-Ring Fiber-Optic
LCD-E3	LCD Keypad Display
PM-9/PM-9G	Power Supply
RPT-E3-UTP	Network Repeater
DACT-E3	Digital Alarm Communicator Transmitter
LCD-7100(Optional)	Remote Serial LCD Display
<b>INCC Intelligent Network Command Center</b>	
1100-0455	ASM-16 Programmable Switch Module (occupies single slot of the inner door)
ANU-48	Remote LED Driver
INCC-ID	Inner door w/6 single slots
INCC-CABR	INCC backbox (black) with red outer door, Dimensions: 19" W x 19" H x 4" D (48 W x 48 H x 10 cm)
1100-0505	NGA Network Graphic Annunciator
<b>INI-VG Series (Third Generation-Voice Gateway Models):</b>	
INI-VGC	Command Center Voice Gateway with unshielded twisted-pair wire networking, optional fiber-optic module connection
FML-E3	Fiber-Optic module, multi-mode fiber connector, single channel
FSL-E3	Fiber-optic module, single-mode fiber connector, single channel
<b>INI-VG Series (Legacy Modules):</b>	
1100-1321	INI-VGC-FO: Command Center Voice Gateway for fiber-optic only
1100-1322	INI-VGC-UTP: Command Center Voice Gateway for unshielded twisted-pair wire only

**Ordering Information**

Part Number	Description
<b>Optional Accessories</b>	
1100-0503	ANU-48, Remote LED Driver
1100-0451	INICC-TEL, Fire Fighter Telephone Handset
1100-0452	INCC-MIC, Paging Microphone Module (occupies one single slot of Inner Door)
1100-0450	Command Center Blank Plate, 3-Pack
<b>INX Intelligent Network Transponder</b>	
<b>INI-VG Series (Third Generation-Voice Gateway Models):</b>	
INI-VGX	Voice Transponder Gateway with unshielded twisted-pair wire networking, optional fiber-optic module connection
FML-E3	Fiber-Optic module, multi-mode fiber connector, single channel
FSL-E3	Fiber-optic module, single-mode fiber connector, single channel
<b>INI-VG Series (Legacy Modules):</b>	
1100-1323	INI-VGX-FO, Transponder Voice Gateway, fiber-optic only
1100-1324	INI-VGX-UTP, Transponder Voice Gateway, unshielded twisted-pair wire only
<b>Power Supply:</b>	
PM-9/PM-9G	INX 9 ampere Power Supply
<b>AM-50 Series Amplifiers:</b>	
1100-0456	AM-50-25, INX 50 Watt Amplifiers 25 V <sub>RMS</sub> only
AM-50-70	INX 50 Watt amplifier 70.7 V <sub>RMS</sub> output
<b>Cabinets:</b>	
INX-CAB	INX Backbox with Black Door Dimensions: 19" W x 19" H x 4" D (48 x 48 x 10 cm)
INX-CABR	INX Backbox with Red Door Dimensions: 19" W x 19" H x 4" D (48 x 48 x 10 cm)
INX CAB-B	Enclosure louvered door and INX-CAB-B mounting plate Dimensions: 19 3/8" W x 19 3/8" H x 4.5" D (49 W x 39 H x 11 D cm)

For additional information on the cabinets, refer to the E3 Series Cabinets Data Sheet (Part Number: 9020-0649).

**Seismic Battery Bracket Kits**

For information on the types of Seismic Battery Bracket Kits available and the Seismic Battery Bracket Kit Part Numbers, refer to the following documents:

Seismic Battery Bracket Installation Guide, P/N: 53839

E3 Series Cabinets Data Sheet P/N: 9020-0649

# E3 Series® Broadband System Technical Specifications

## SYSTEM

Detailed product specifications may be found in the following documents:

**9020-0542:** INCC Intelligent Network Command Center Data Sheet

**9020-0637:** E3 Series Control Panel Data Sheet

**9020-0541:** INX Intelligent Network Transponder Data Sheet

**9021-60758:** E3 Series Combined Fire and Mass Notification Data Sheet

## TEMPERATURE AND HUMIDITY RANGES

This system meets NFPA requirements for operation at 0 – 49°C/32 – 120°F and at a relative humidity 93% ± 2% RH (non-condensing) at 32°C ± 2°C (90°F ± 3°F).

However, the useful life of the system's standby batteries and the electronic components may be adversely affected by extreme temperature ranges and humidity. Therefore, it is recommended that this system and its peripherals be installed in an environment with a normal room temperature of 15 – 27°C/60 – 80°F.

## STANDARDS

The E3 Series Broadband System is designed to comply with the following standards:

**UL Standards:** UL 864 9th Edition

UL 2572 for Mass Notification

## AGENCY LISTINGS AND APPROVALS

These listings and approvals apply to the modules specified in this document. In some cases, certain modules or applications may not be listed by certain approval agencies, or listing may be in process. Consult the factory for the latest listing status.

**UL Listed:** S1869, 2572 for Mass Notification

**FM Approved:** 3025415

**MEA FDNY:** 6175 231-06-2E

**CSFM:** 7165-1703:125

**City of Chicago Approved:** 7165-1703:125

**City of Denver Approved**

**ISO 9001 Certification**

For a complete listing of all compliance approvals and certifications, please visit:

<http://www.gamewell-fci.com/en-US/documentation/Pages/Listings.aspx>

E3 Series® and Gamewell-FCI® are registered trademarks of Honeywell International Inc.

UL® is a registered trademark of Underwriters Laboratories Inc

This document is not intended to be used for installation purposes. We try to keep our product information up-to-date and accurate. We cannot cover all specific applications or anticipate all requirements. All specifications are subject to change without notice.

## For more information

Learn more about Gamewell-FCI's E3 Series® Broadband System and other products available by visiting [www.Gamewell-FCI.com](http://www.Gamewell-FCI.com)

## Honeywell Gamewell-FCI

12 Clintonville Road

Northford, CT 06472-1610

203.484.7161

[www.honeywell.com](http://www.honeywell.com)

9020-0613 | 0 | 10/18

©2018 Honeywell International Inc.

**Honeywell**