

TX3-CX-1NP Installation

These instructions explain how to install the TX3-CX-1NP in the following TX3 units:

- | | | | |
|-------------------|-------------------|--|-----------------|
| TX3-TOUCH-F15-B/C | TX3-200-8U-B/C | TX3-1000-8U-B/C | TX3-2000-8U-B/C |
| TX3-TOUCH-S15-B/C | TX3-200-8C-B/C | TX3-1000-8C-B/C | TX3-2000-8C-B/C |
| TX3-TOUCH-F22(-C) | TX3-TOUCH-S22(-C) | TX3-TOUCH-S15B-WR and
TX3-TOUCH-S15S-WR | |

A. Contents of Kit

- Qty 1... TX3-CX-1NP
- Qty 2... Nuts for attaching TX3-CX-1NP to the TX3 unit
- Qty 1... USB cable for programming TX3-CX-1NP
- Qty 1... USB flash containing TX3 software and manuals

B. Mount TX3-CX-1NP

1. Mount TX3-CX-1NP on the two posts as shown in Figure 1.
2. Secure it with the provided nuts.

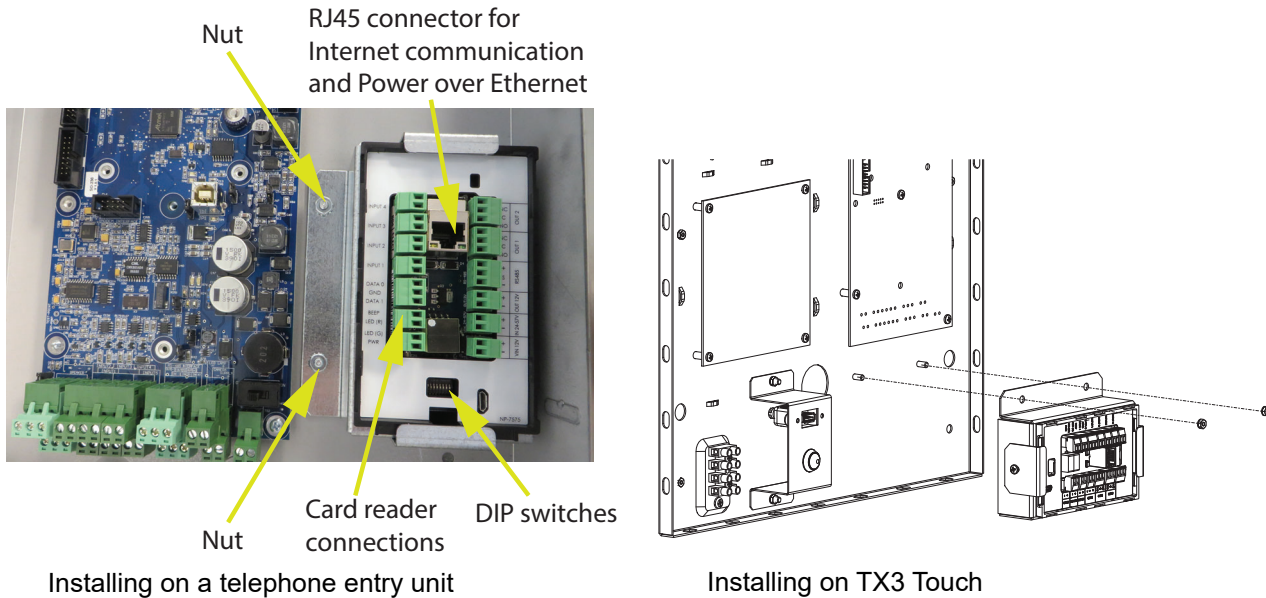

Figure 1 Mount TX3-CX-1NP

C. Set the RS-485 Address

- Use DIP switches 1-6 (shown in Figure 1) to set the RS-485 network address.



Figure 2 Set the RS-485 address

Note: You must set the RS-485 address even if you are not using RS-485.

- Belden 72001E ETHERNET Cat 5e 2 Pair, 24 AWG or equivalent
- Belden 70006E Cat 5e, 100Mb/s, Quad, AWG 22 (1) or equivalent

Maximum total length:

- 4000 feet (1244 m) for 22 AWG
- 2500 feet (762.5 m) for 24 AWG

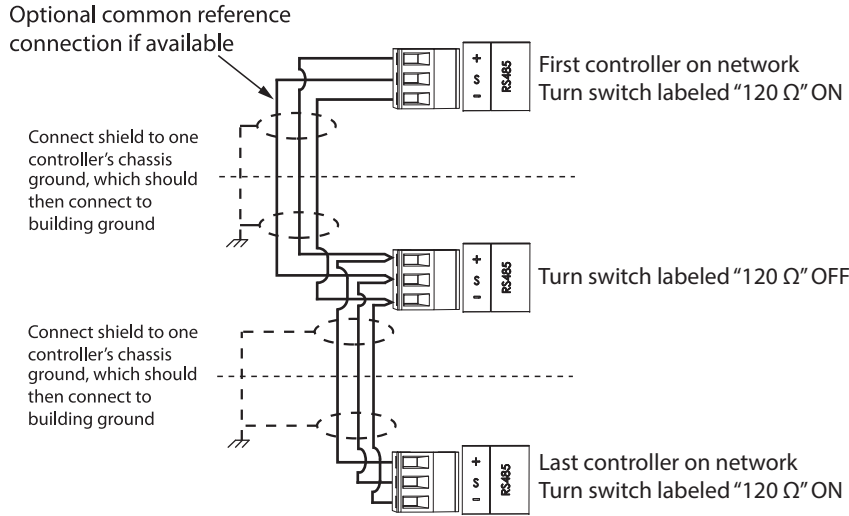

Figure 4 RS-485

USB Port

The USB port provides a connection to a PC, for configuring the Card Access System and upgrading the firmware.

Inputs

Inputs 1 to 4 are programmable inputs. For details on the active state and supervision of the inputs, see LT-980 on the Mircom website (www.mircom.com) or the USB flash.

For details on programming the inputs, see LT-995 on the Mircom website (www.mircom.com) or the USB flash.

Outputs

For details on programming the outputs, see LT-995 on the Mircom website (www.mircom.com) or the USB flash.

E. Connect the Power

The Single Door Controller can be powered in three ways. Use only one of the power inputs.

- Power over Ethernet (PoE) - use Cat 5 cable
- 12 VDC/15 W - use 18 AWG
- 24-48 VDC/15 W - use 20-18 AWG

F. Card Reader Beeper

The beeper indicates specific events at different beep rates as follows:

- **Card Presented.** One short beep.
- **Access Granted.** Two short beeps.
- **Access Denied.** One short beep and one long beep.
- **Mode of Operation Changed.** Three short beeps indicate a change in the on or off state for the high security or the unlock mode.

- **Alarm.** Continuous short beeps.

G. Update Firmware

Refer to LT-995 on the Mircom website (www.mircom.com) or the USB flash for instructions on how to upgrade the firmware.

H. Install the TX3-P300-HA Card Reader

See LT-969 the Telephone Access Installation and Operation Manual on the Mircom website (www.mircom.com) or the USB flash for instructions on installing the TX3-P300-HA card reader in the lobby control units.

I. Wire the TX3-P300-HA Card Reader to TX3-CX-1NP

Color of Reader Wire	Terminal on TX3-CX-1NP
Green	DATA0
Black	GND
White	DATA1
Blue	BEEP
Brown	LED (R)
Orange	LED (G)
Red	PWR

Card reader requirements

Card readers must meet the following minimum requirements in order to be compatible with Mircom's Card Access System:

- Standard Wiegand interface
- LED status indicator
- Warning or alarm buzzer
- 12 Volt operation
- Maximum distance 500 ft (152.4 m)
- Use 20 AWG for 500 ft (152.4 m)
- Use 22 AWG for 250 ft (76.2 m)
- For other card readers, consult your reader installation manual for recommended distances and gauges

See LT-980 the Card Access System Manual on the Mircom website (www.mircom.com) or the USB flash for more information.