

Features

- Resets itself, nothing to replace, testable
- Offers various temperature settings
- Long lasting stainless steel shell
- Wide spacing, reduces installation cost
- Factory set
- Internal contact area hermetically sealed in stainless steel



Description

The Kidde-Fenwal® DETECT-A-FIRE® units are the “heart” of many Fire Protection Systems. These highly reliable devices have been a standard of the industry for 65 years, with thousands of detectors in use controlling the release of extinguishants such as clean agents, CO₂, water, or dry chemicals. In some systems the device is used as an ALARM device, to sense overheat or fire, and alert personnel. In select systems, the device is used as an ALARM device, to sense overheat or fire and alert personnel.

DETECT-A-FIRE detectors have met with wide acceptance because they are designed with RATE COMPENSATION. This provides a unique advantage over both fixed temperature and rate-of-rise types of detectors because only the DETECT-A-FIRE detector accurately senses the surrounding air temperature regardless of the fire growth rate. At precisely the predetermined danger point, the system is activated.

Fixed temperature detectors must be completely heated to alarm temperature and therefore a lag in response time may occur with a fast rate fire. Rate-of-rise devices, on the other hand, are triggered by the rate of increase in ambient temperature and are subject to false alarms caused by harmless, transient thermal gradients such as the rush of warm air from process ovens.

Technical Specifications

Material	Shell: Type 300 Stainless steel Mounting: Cold rolled steel/ Type 300 Stainless steel/brass Finish: Off-white
Weight	5 oz

The key to the unit’s sensitivity is in the design. The outer shell is made of a rapidly expanding alloy which closely follows changes in surrounding air temperature. The inner struts are made of a lower expanding alloy. Designed to resist thermal energy absorption and sealed inside the shell, the struts follow temperature changes more slowly. A slow rate fire will heat the shell and struts together. At the “set point,” the unit will trigger, actuating the alarm or releasing the extinguishant.

A transient rush of warm air up to 40°F/min may expand the shell, but not enough to trigger the unit. By ignoring transient warm air excursions, DETECT-A-FIRE detectors virtually eliminate false alarms prevalent with rate-of-rise devices.

If a fast rate fire starts, the shell will expand rapidly. The struts will close, actuating the alarm or releasing the agent. The faster the fire rate of growth, the sooner the DETECT-A-FIRE detector will react.

Horizontal Detect-A-Fire Units

Horizontal DETECT-A-FIRE detectors are designed for locations where appearance is a factor. The low profile, functional design lends physical protection of the unit while making it suitable for commercial, industrial, mercantile and public buildings, institutions and marine applications in non-hazardous locations (those classified as “ordinary” under the National Electric Code). Flush mounted units are designed to fit standard 4” octagonal electrical boxes and surface mounting units are designed to mount directly on ceilings or on 4” electrical junction boxes. Canadian Electrical Codes requires mounting only to an electrical junction box.

Mounting (Horizontal and Vertical)

DETECT-A-FIRE detectors are not position sensitive. Horizontal and vertical detectors refer to the most common mounting configuration for that unit. However, each type can be mounted either horizontally or vertically depending on the application and installation requirements.



Flush Mounting Unit
for Concealed Wiring



Surface Mounting Unit
for Exposed Wiring

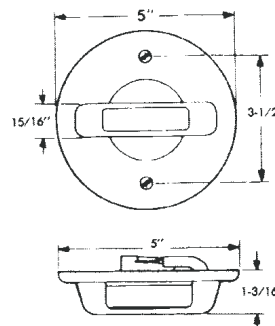

12-X27020-000
12-X27020-001

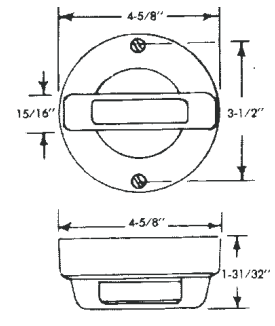

12-X27020-001
12-X27021-001

Hazardous Locations	Detector Type	Fitting Required For UL & ULC Listings and FM Approval
Class I, Groups A, B C and D; Class II Groups E, F and G	12-X27120-022 12-X27121-020 12-X28020-003 12-X28021-005	Mount detector to a suitable listed fitting in accordance with National Electric Code and/or local authority having jurisdiction.
Class I, Groups B, C and D; Class II, Groups E, F and G	12-X27120-000 12-X27121-000	

Model Number	Contract Operation on Temperature Rise	Approx. Weight Per Unit	Electrical Rating (Resistive Only)
12-X27020-000 12-X27020-001	Opens (325°F Max.)	10 oz.	5.0 Amps 125 VAC 0.5 Amps 125 VDC
12-X27021-000 12-X27021-001	Closes (325°F Max)	10 oz.	5.0 Amps 125 VAC 0.5 Amps 125 VDC 2.0 Amps 24 VDC 1.0 Amps 48 VDC

Notes

- DETECT-A-FIRE detectors are temperature preset at the factory.
- For corrosive environments, care should be taken to protect the DETECT-A-FIRE detector to obtain optimal performance and maximum life. Consult factory for fluorocarbon coating option.
- For field wiring requirements to connect to DAF, please refer to DAF installation instructions.
- Per UL521 requirements - low temperature exposure test is -22°F (-30°C).
- DETECT-A-FIRE detectors are designed for long life expectancy, however due to various field conditions it is required that the detectors be tested annually per NFPA guidelines or local fire codes.
- Replace DETECT-A-FIRE after any fire or heat related event, any mechanical damage, or after 10 years of continuous service.
- UL of Canada labeling available upon request.
- DETECT-A-FIRE detectors are CE Listed. The product family has been evaluated in accordance with IEC 60947-1 and IEC 60947-5-1, and is documented under Intertek Report No. 102294754 BOX-001 as an overheat detector. Detectors have a rated insulation and impulse voltages of 1500 Vac.

Temperature Rating

(Suggested setting a minimum of 100°F above ambient)

	°F Setting	°F Tolerance	Spacings (in feet)			RTI	Color Coding
			UL	ULc	FM		
A	140	+7/-8	50	50	20	Quick	Black
	160	+7/-8	25	25	20	Quick	Black
	190	+7/-8	50	50	25	Fast	White
	210	+7/-8	25	50	25	Fast	White
	225	+7/-8	25	50	25	Fast	White
B	275	10	25	50	25	Fast	Blue
	325	10	50	50	25	Fast	Red

Vertical Detect-A-Fire Units

Vertical detectors are designed for use in both “ordinary” or “hazardous” locations. For “ordinary” use, they may be mounted to any approved junction box with 7/8” diameter opening by using 1/2-14 NPT mounting nuts. The device may be wired in or out of conduit, depending on local preference and codes. To facilitate supervision of system wiring, four wire leads are provided on normally open vertical units (that close on temperature rise). When mounted in a suitable enclosure, detectors are Underwriters Laboratory and Underwriters Laboratory of Canada listed, and Factory Mutual approved for hazardous locations.

Vertical Detect-A-Fire Units

For Concealed and Exposed Wiring
(Hexagonal Head)

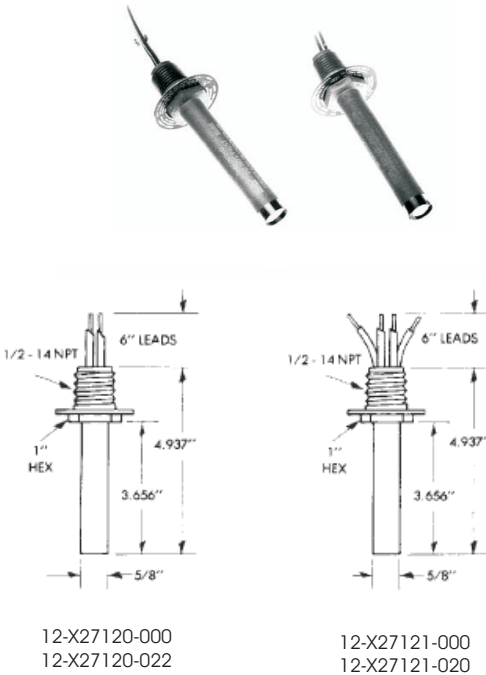

12-X27120-000
12-X27120-022

12-X27121-000
12-X27121-020

Vertical Detect-A-Fire Units

For Concealed and Exposed Wiring
(Coupling Head)

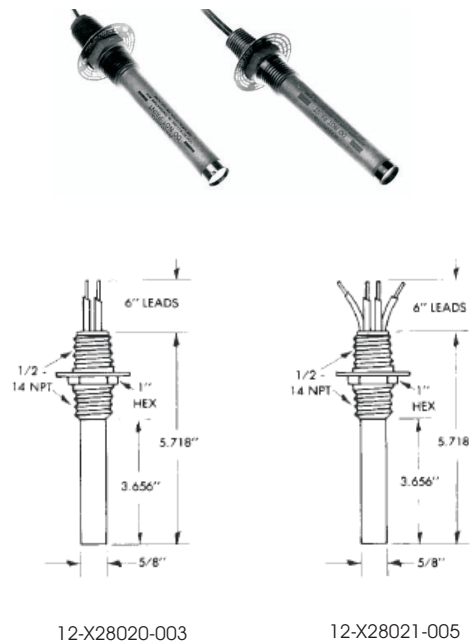

12-X28020-003

12-X28021-005

DETECT-A-FIRE Part Selection Guide for Vertical DETECT-A-FIRE Detectors

Model Number	Mounting Head Material	Shell Material	Contact Operation on Temperature Rise	Electrical Rating (Resistive Only)	Approx. Weight Per Unit
12-X27120-000 12-X27120-022	Brass Type 300 Stainless Steel	Type 300 Stainless Steel	Opens (450°F Max)	5.0 Amps 125 VAC 0.5 Amps 125 VDC	5 ox.
12-X27121-000 12-X27121-020	Brass Type 300 Stainless Steel		Closes	5.0 Amps 125 VAC 0.5 Amps 125 VDC 2.0 Amps 24 VDC 1.0 Amps 48 VDC	5 oz.
12-X28020-003	Type 300 Stainless Steel		Opens (450°F Max)	5.0 Amps 125 VAC 0.5 Amps 125 VDC	5 oz.
12-X28021-005	Type 300 Stainless Steel		Closes	5.0 Amps 125 VAC 0.5 Amps 125 VDC 2.0 Amps 24 VDC 1.0 Amps 48 VDC	5 oz.

Agency Listings

DETECT-A-FIRE detectors are UL and ULC listed and FM approved as fire detection thermostats (close on temperature rise) and as releasing devices (open on temperature rise).

Agency	File Number	Location
UL	S492	Ordinary
UL	E19310	Hazardous
ULC	CS341-E	Ordinary and Hazardous
FM	J.I. OV2HO.AE	Hazardous
FM	17302	Ordinary
UL	S2410	Ordinary (600 & 725°F)
UL	E89599	Hazardous (600 & 725°F)
CE	IEC 60947-5-1	-

Ordering Information

Part Number	Ordering Part Number	Description
27121-0XXX	Call for Part Number	Heat Detector, Vertical Mount, 140, 160, 190, 225 degrees, N/O
27121-0XXX	Call for Part Number	Heat Detector, Vertical Mount, 275, 325, 360 degrees, N/O
27121-0XXX	Call for Part Number	Heat Detector, Vertical Mount, 450, 500 degrees, N/O
27121-0XXX	Call for Part Number	Heat Detector, Vertical Mount, 600, 725 degrees, N/O
27120-0XXX	Call for Part Number	Heat Detector, Vertical Mount, 140, 160, 190, 225 degrees, N/C
27120-0XXX	Call for Part Number	Heat Detector, Vertical Mount, 275, 325, 360 degrees, N/C
27120-0XXX	Call for Part Number	Heat Detector, Vertical Mount, 450 degrees, N/C
06-116317-001	Call for Part Number	Junction box for explosion-proof heats

Vertical Models

Table 1: Model No. 12-X27120, 12-X27121

	°F Setting	°F Tolerance	Spacings (in feet)			RTI	Color Coding
			UL	ULc	FM		
E	140	+7/-8	50	50	20	V-Fast	Black
	160	+7/-8	25	25	20	V-Fast	Black
	190	+7/-8	50	50	25	V-Fast	White
	210	+7/-8	25	50	25	V-Fast	White
	225	+7/-8	25	50	25	V-Fast	White
F	275	+10	25	50	25	V-Fast	Blue
	325	+10	50	50	25	V-Fast	Red
	360	+10	25	50	30	V-Fast	Red
G	450	+15	25	50	30	V-Fast	Green
	500	+15	50	50	30	V-Fast	Orange
H	600	+20	N/A	50	30	V-Fast	Orange
	725	+20	N/A	50	30	V-Fast	Orange

Table 2: Model No. 12-X28020, 12-X28021

	°F Setting	°F Tolerance	Spacings (in feet)			RTI	Color Coding
			UL	ULc	FM		
E	140	+7/-8	50	50	30	V-Fast	Black
	160	+7/-8	25	25	30	V-Fast	Black
	190	+7/-8	50	50	30	V-Fast	White
	210	+7/-8	25	50	30	V-Fast	White
	225	+7/-8	25	50	30	V-Fast	White
F	275	+10	25	50	30	V-Fast	Blue
	325	+10	50	50	30	V-Fast	Red
	360	+10	25	50	30	V-Fast	Red
G	450	+15	25	50	30	V-Fast	Green
	500	+15	50	50	30	V-Fast	Orange
H	600	+20	N/A	50	30	V-Fast	Orange
	725	+20	N/A	50	30	V-Fast	Orange

Notes

- For clean agents and CO2 suppression systems, ceiling spacing is 20 ft. apart unless otherwise specified.
- 27120 and 28020 are 2-wire devices and RTI is not applicable
- 27120 and 28020 are normally closed devices and does not meet the requirements of NFPA-72 for use as an initiating device