

Reliable®

Model RRMA and RTMA Air Compressors

Product Features

- Six riser mount tank-less options (RRMA)
- Five tank mounted options (RTMA)
- Quiet oil-less piston compressors
- UL Listed pressure switch
- Flexible connection kits

Product Description

Reliable Model RRMA (tank-less) and RTMA (tank-mount) Air Compressors provide a compact compressed air source for dry pipe and preaction fire protection systems. Model RRMA compressors are provided with convenient means of mounting to 2" through 8" system piping, while Model RTMA models are intended to be secured to the floor.

Model RRMA compressors are available with two factory preset options. For low pressure systems such as the Reliable Model DDX-LP dry pipe system and Model DDX preaction systems, Model RRMA-2026 compressors are preset to cut-in at 20 psi (1.4 bar) and cut-out at 26 psi (1.8 bar), and are provided with a 75 psi (5.2 bar) safety relief valve. For differential dry pipe valves such as the Reliable Model FX and Model D, Model RRMA-CP compressors are preset to cut-in at 40 psi (2.8 bar) and cut-out at 50 psi (3.4 bar), and are provided with a 100 psi (6.9 bar) safety relief valve.

Model RTMA compressors are factory preset to cut-in at 80 psi (5.5 bar) and cut-out at 100 psi (6.9 bar) and are provided with a 125 psi (8.6 bar) safety relief valve.

NFPA 13 requires an air receiver and an approved pressure maintenance device for compressors that produce more than 5.5 CFM (160 L/min). All Model RRMA compressors are below this capacity; therefore, the air receiver and pressure maintenance device are not required when supplying a single system. A Model RTMA tank-mounted compressor with a single Model A pressure maintenance device is also an acceptable arrangement for a single system.

When supplying more than one system from a single compressor, a Model RTMA tank-mounted compressor must be used along with an Model A pressure maintenance device for each system.

Connection kits for Models RRMA and RTMA compressors are available and include the required air pressure gauge along with a 1/2" x 30" stainless steel hose. The connection kit for the Model RTM compressor also includes a Reliable Model A Pressure Maintenance Device.

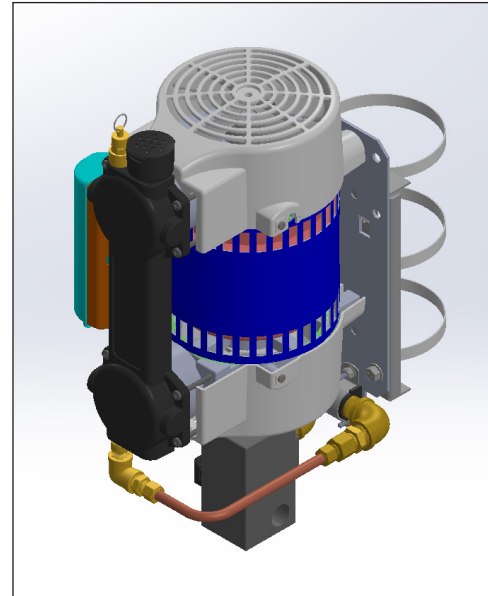

Model RRMA (Tank-less)

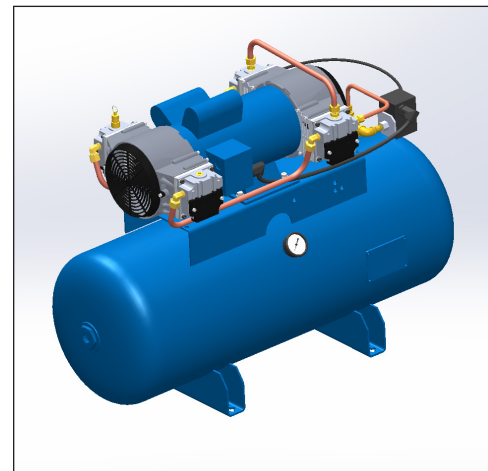

Model RTMA (Tank-mounted)

Dimension and Weights - RRMA Tank-less Compressor

Figure 1

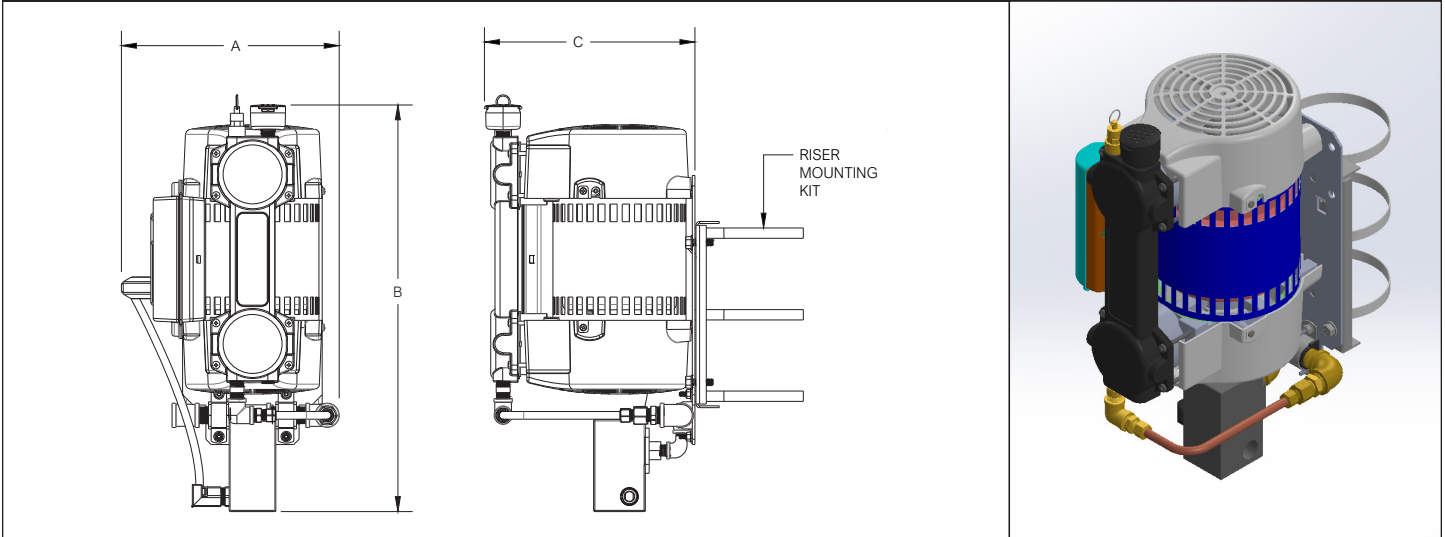

Table A

Motor HP	A	B	C	Weight
1/6	9-1/4" (235 mm)	16-1/4" (410 mm)	7-1/2" (190mm)	29 lbs (13.2 kg)
1/3	9-1/4" (235 mm)	17-1/2" (445 mm)	7-1/2" (190mm)	33 lbs (15 kg)
1/2	9-1/4" (235 mm)	19-3/4" (500 mm)	10-1/4" (260 mm)	45 lbs (20.4 kg)

Approximate System Capacity Based on 30-Minute Fill Time

Table B

Model	Motor HP	System Capacity at 15 psi (1.03 bar) gallons [liters]	System Capacity at 20 psi (1.4 bar) gallons [liters]	System Capacity at 40 psi (2.8 bar) gallons [liters]
RRMA23016 - [2026] [4050]	1/6	334 [1264]	250 [946]	110 [416]
RRMA40033 - [2026] [4050]	1/3	577 [2184]	455 [1722]	200 [757]
RRMA70050 - [2026] [4050]	1/2	986 [3732]	735 [2782]	330 [1249]

Notes:

1. Last four digits of model number designate factory pressure settings. Choose 2026 for cut-in at 20 psi, cut-out at 26 psi. Choose 4050 for cut-in at 40 psi and cut-out at 50 psi.
2. The capacity of all model RRMA compressors is below 5.5 cfm (160 L/min); therefore, an air receiver and air maintenance device are not required when supplying a single system.
3. See Figure 5 for connection kit information.

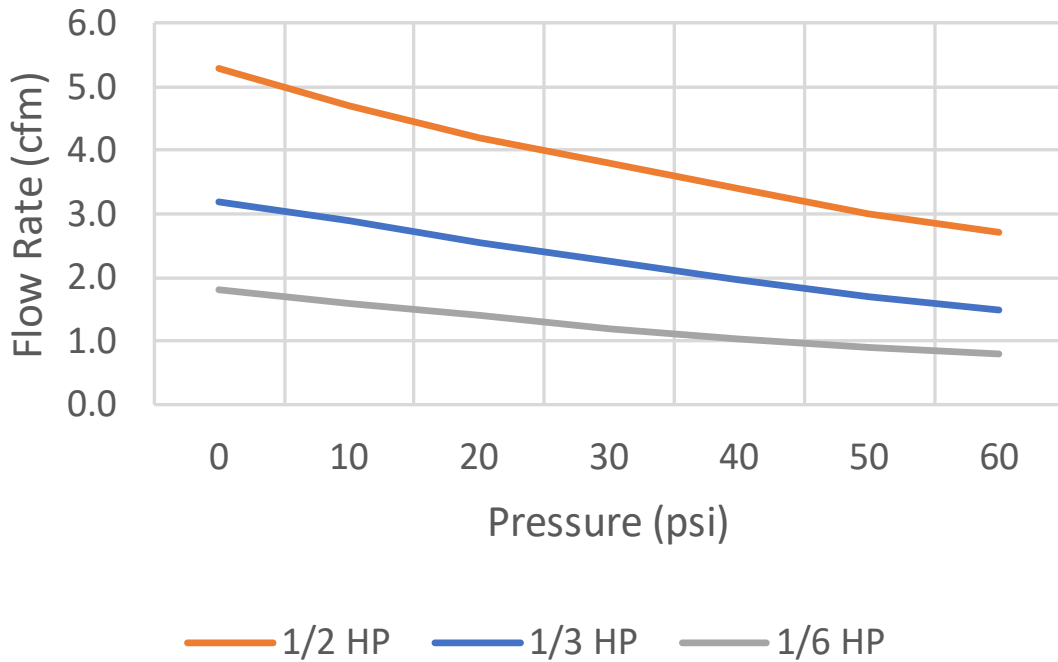

Tank-less Compressor Electrical Characteristics

Table C

Motor HP	Voltage/Hz/Phase	Full Load Amperage	Start Up Amperage
1/6	115/60/1	4.4	26
	208-230/60/1	2.2	13
1/3	115/60/1	6.8	39
	208-230/60/1	3.4	20
1/2	115/60/1	9.4	55
	208-230/60/1	4.9	28

Notes:

1. All tank-less mounted compressors are pre-wired for 115 VAC. Instructions for use with 208-230 VAC power are provided under the pressure switch cover
2. Wiring and wire size to be in strict accordance with the National Electrical Code. In no case shall wiring be less than 12 gauge.

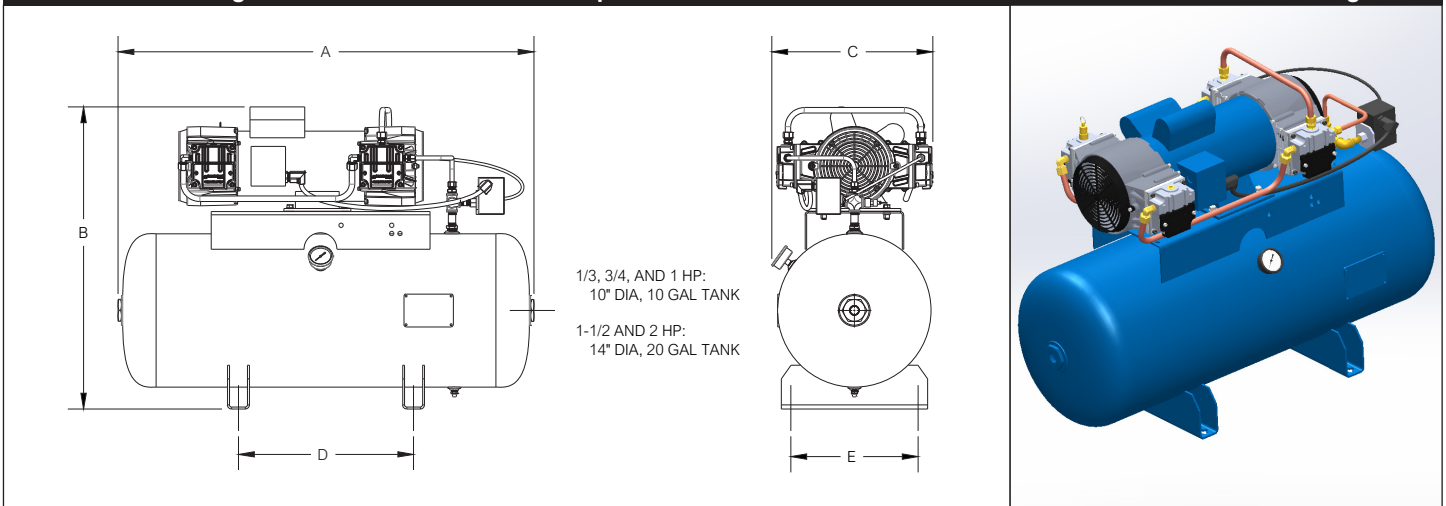

Table D

Motor HP	A	B	C	D	E	Weight
1/3	33-1/4" (845 mm)	22-3/4" (580mm)	11-3/4" (300mm)	16" (400mm)	9" (230mm)	87 lbs (39.5 kg)
3/4	33-1/4" (845 mm)	25-1/2" (650mm)	11-3/4" (300mm)	16" (400mm)	9" (230mm)	98 lbs (44.5 kg)
1	33-1/4" (845 mm)	25-1/2" (650mm)	11-3/4" (300mm)	16" (400mm)	9" (230mm)	98 lbs (44.5 kg)
1-1/2	38" (965 mm)	27-1/2" (700 mm)	14-3/4" (375mm)	16" (400mm)	9" (230mm)	128 lbs (58 kg)
2	38" (965 mm)	27-1/2" (700 mm)	14-3/4" (375mm)	16" (400mm)	9" (230mm)	138 lbs (62.6 kg)

Note: Dimensions D and E are to center of 7/16" x 1" mounting slots in tank saddle.

Approximate System Capacity Based on 30-Minute Fill Time

Table E

Model	Motor HP	System Capacity at 15 psi (1.03 bar) gallons [liters]	System Capacity at 20 psi (1.4 bar) gallons [liters]	System Capacity at 40 psi (2.8 bar) gallons [liters]
RTMA25033-80100	1/3	562 [2127]	425 [1609]	200 [757]
RTMA36575-80100	3/4	960 [3634]	720 [2725]	325 [1230]
RTMA550100-80100	1	1394 [5277]	1050 [3374]	435 [1874]
RTMA915150-80100	1-1/2	2300 [8706]	1740 [6586]	815 [3085]
RTMA1100200-80100	2	2458 [9305]	1865 [7059]	880 [3331]

Notes:

1. Last four digits of model number designate factory pressure settings (e.g., 80100 = cut in 80 psi, cut out 100 psi).
2. Model RTMA compressors are required to utilize a Model A pressure maintenance device.
3. When supplying multiple systems with a single RTMA compressor, NFPA 13 requires each system to have its own pressure maintenance device.
4. See Figure 5 for connection kit information.

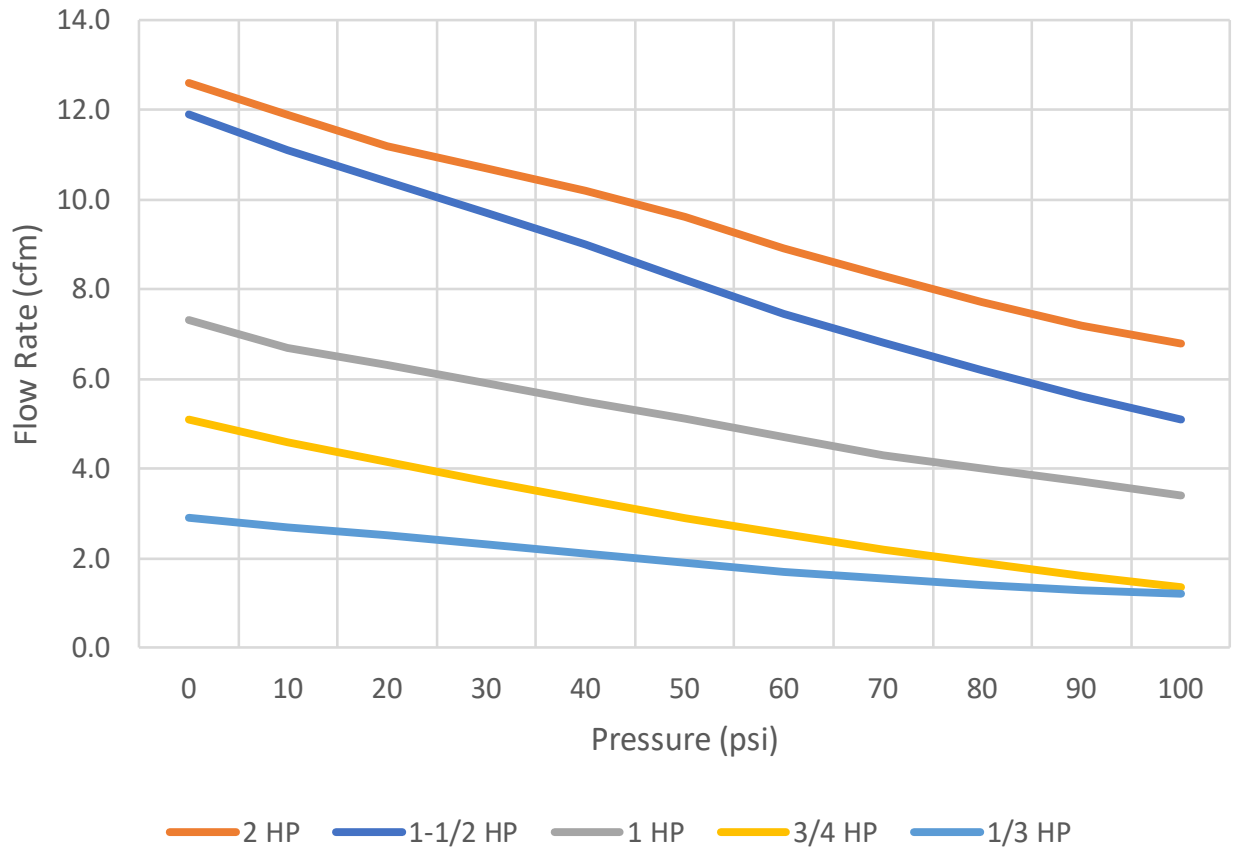

Tank-mounted Compressor Electrical Characteristics

Table F

Motor HP	Voltage/Hz/Phase	Full Load Amperage	Start Up Amperage
1/3	115/60/1	6.8	39
	208-230/60/1	3.4	20
3/4	115/60/1	9.9	57
	208-230/60/1	5.1	30
1	115/60/1	11.3	66
	208-230/60/1	5.7	33
1-1/2	115/60/1	16.6	96
	208-230/60/1	8.3	48
2	115/60/1	NA	NA
	208-230/60/1	11.6	67

Notes:

1. All tank-mounted compressors are pre-wired for 230 VAC. Instructions for use with 115 VAC power are provided under the pressure switch cover (except 2 HP).
2. Wiring and wire size to be in strict accordance with the National Electrical Code. In no case shall wiring be less than 12 gauge.

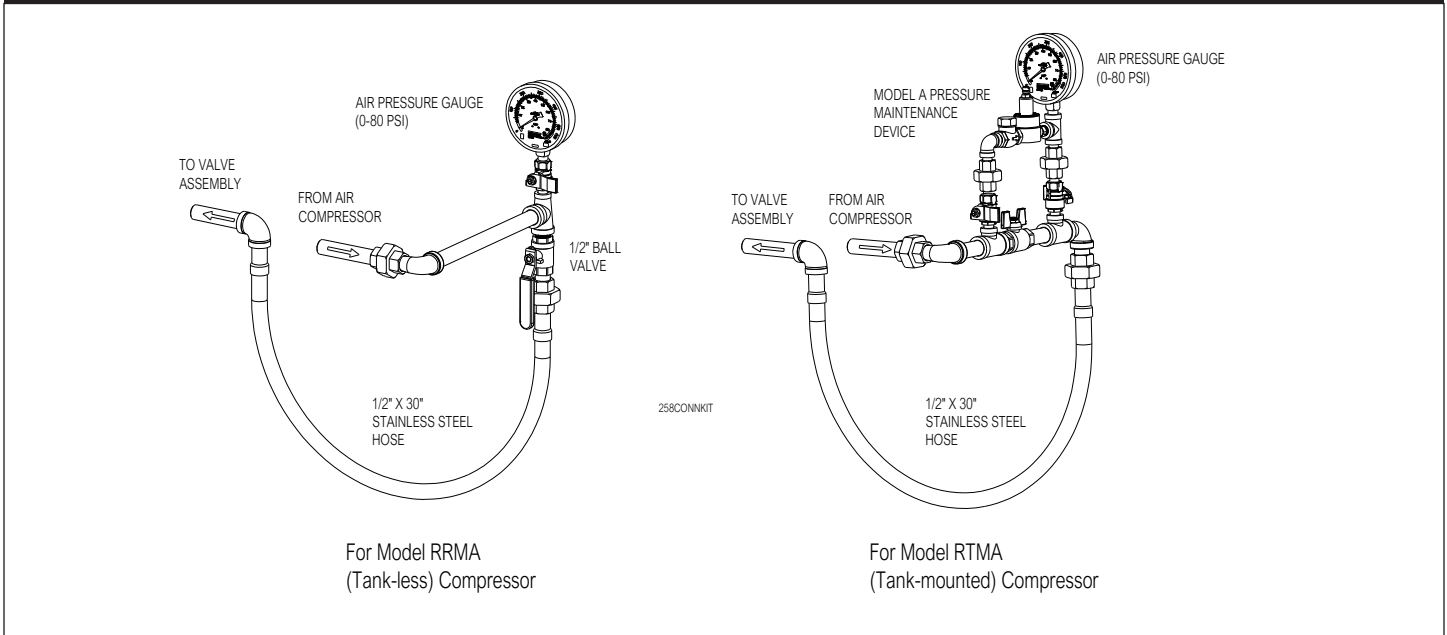

Notes:

1. See Reliable Bulletin 251 for additional information on Model A Pressure Maintenance Device.
2. 1/2" x 30" stainless steel hose may be purchased separately (P/N 6872000000).

Installation and Adjustment

Locate the compressor in a clean, well ventilated area where the minimum temperature is maintained between 40° F (4° C) and 104° F (40° C). Provide at least 12" of clearance on all sides from walls or other obstructions that may interfere with airflow over and through the compressor. The compressor must be wired in accordance with the National Electric Code to a properly grounded circuit using minimum 12-gauge wire. When necessary, pressure adjustment can be made by turning the Main Calibration Screw under the cover of the pressure switch. This will increase both the cut-in and cut-out pressures without affecting the differential. *Adjustment of the Differential Pressure Screw is not recommended.*

Please refer to Reliable "RRMA/RTMA Series Installation, Operation, and Maintenance Manual" located on Reliable's website (www.reliablesprinkler.com) for additional information.

Maintenance

The owner is responsible for maintaining all parts of the fire protection system in proper operating condition. Any system maintenance or testing that involved placing a system component out of service may eliminate the fire protection that is provided by the fire protection system.

The Reliable Model RRMA/RTMA Air Compressor shall periodically be given a thorough inspection and test. NFPA 25, "Inspection, Testing, and Maintenance of Water Based Fire Protection Systems," provides minimum maintenance requirements. System components shall be tested, operated, cleaned, and inspected at least annually and parts replaced as required.

Guarantee

For the Reliable Automatic Sprinkler Co., Inc. guarantee, terms, and conditions, visit www.reliablesprinkler.com.

Ordering Information

Specify the following when ordering.

Model RRMA (Tank-less)

- 1/6 HP [20 - 26 psi] [40 - 50 psi]
- 1/3 HP [20 - 26 psi] [40 - 50 psi]
- 1/2 HP [20 - 26 psi] [40 - 50 psi]

Model RTMA (Tank-mounted)

- 1/3 HP
- 3/4 HP
- 1 HP
- 1-1/2 HP
- 2 HP

Optional Connection Kit

- Tank-less
- Tank-mounted
- Stainless Steel Hose Only