



# TX Residential Series Tanks

## THERMAL EXPANSION ABSORBER FOR FRESH WATER

### INSTALLATION INSTRUCTIONS

#### APPLICATION

The Thermal Expansion Absorber is a pre-pressurized expansion tank with a butyl diaphragm designed to control excess pressure in potable hot water systems. Its use for household as well as small commercial hot water heaters will save energy and reduce operating problems by preventing relief valve operation due to excess system pressure.

#### INSTALLATION

Connect the Thermal Expansion Absorber tank to the cold water inlet line of the water heater. The tank connection must be between the water heater and any valve or backflow preventer.

Adjust the tank air pressure to the minimum cold water pressure by adding or releasing air from the tank. Fill tank and piping with cold water. Open a hot water faucet to allow a small trickle of water. Turn on water heater and allow it to come up to its normal operating temperature. Close the hot water faucet.

#### SPECIFICATIONS

**Maximum allowable working pressure:** 150 psig/1034 kPa

**Maximum allowable working temperature:** 200 °F/93 °C

**Standard Factory Air Charge:** 40 psig/276 kPa

NOTE: Relief valve must be set at 150 psig maximum.

**Materials:** Diaphragm: Butyl Rubber Compound  
 Liner: Polypropylene  
 Connection: Stainless Steel

**Approvals:** NSF61, City of Los Angeles and others.  
 Listed by IAPMO

**Fig. 2 Based On:**

- Heating water from 70 °F to 140 °F
- Maximum pressure maintained at least 10% below relief valve setting (150 PSIG).
- Tank air charge matched to city supply pressure.

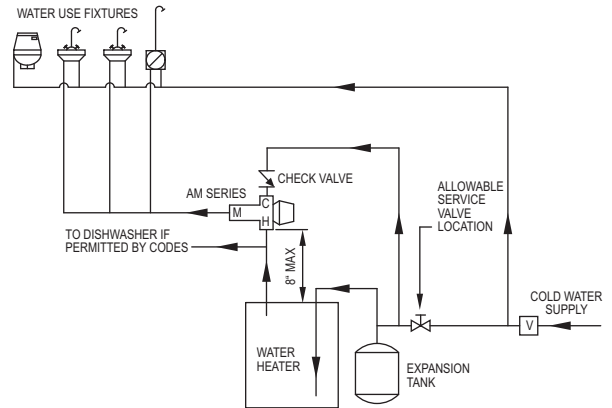

Fig. 1. Typical Installation

**SYMBOLS**

V = Any device which turns the domestic water system into a closed system such as; backflow preventers, check valves or pressure reducing valves.

NOTE: "V" is optional depending on local codes. If a "V" type valve is used, it is mandatory that a thermal expansion tank be installed as shown. Otherwise, dangerously high pressures could result or water heater safety relief valve will frequently expel water. If no "V" device is used, the thermal expansion tank is not required.

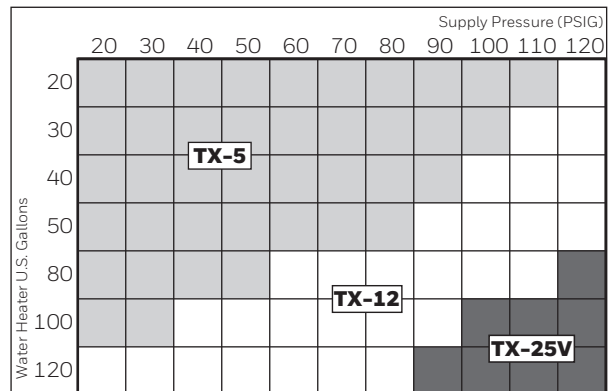

Fig. 2. Quick Sizing Chart.



PRODUCT INFORMATION

Model No.	Total Volume	Max. Acceptance Volume	Dimensions		NPT System Connection*
			Diameter	Length	
TX-5	2.0 Gal.	0.9 Gal.	8"	13"	3/4" M
TX-12	4.4 Gal.	3.2 Gal.	11"	15"	3/4" M
TX-25V	10.3 Gal.	10.3 Gal.	15"	19"	3/4" F

\*Connections: M = Male NPT F = Female NPT



Resideo Technologies, Inc.  
1985 Douglas Drive North, Golden Valley, MN 55422  
1-800-468-1502  
33-00531-03 SA Rev. 06-23 | Printed in United States

[www.resideo.com](http://www.resideo.com)