



VC7936

NO/NC MODULATING CARTRIDGE/CAGE VALVE WITH POWER FAILURE REPOSITION

PRODUCT DATA



The VC7936 Fail Safe Modulating Control Valve provides proportional control of hot or chilled water in commercial heating and cooling applications, such as unit ventilators. On a power failure, this patented actuator design drives the valve to the fail safe position, either fully open or closed, according to the installer's wiring connections.

The VC7936 uses a microprocessor-controlled, low voltage stepper motor with a supercapacitor-based power supply capable of storing enough power to drive the valve to its fail safe position when 24V power is removed from the actuator. DIP switches are used to select actuator response time, flow characterization, motor timing, and control signal.

SPECIFICATIONS

The specifications following are nominal and conform to generally accepted industry standards. Resideo is not responsible for damages resulting from misapplication or misuse of its products.

Power:
24V, 50-60 Hz, 12 W. Class 2 circuit
18 VA maximum (during start up).

Analog Control Signal:
0-10 or 2-10Vdc, proportional signal into polarity-protected, 19 kilo-ohm input impedance.
4-20 mA dc proportional signal with external 499 ohm 1% dropping resistor (not included).

Digital Control Signal:

- 24 Vac, 1.5mA Floating Signal (two mutually-exclusive momentary contacts for open and close, with minimum 0.5 seconds on and off timing.)
- 24 Vac, 1.5mA Pulse Width Modulated Signal (repeating voltage pulse up to 30 second period, with minimum 0.5 seconds on and off timing.)
- 24 Vac, 1.5mA on-off control (contact closure over 30 seconds in duration, not suitable for use with power stealing thermostats or thermostats with anticipators)

Annunciation: red LED on cable end.

Nominal Control Timing: 60 or 120 seconds full stroke depending on DIP switch setting.

Electrical Termination:

5 feet (1.5 m) plenum-rated cable per UL94-5V.
Flexible conduit (3/8") clamp included.

Operating Ambient:

32 to 150 °F (0 to +65 °C).
5-95% RH (non-condensing)

Shipping and Storage Temperature:

-40 to 150 °F (-40 to +65 °C)

Atmosphere: Non-corrosive, non-explosive.

Approvals:

UL (plenum rating), CE (pending)
FCC Part 15 Class B

Fluid temperatures: 34 to 203 °F (1 to 95 °C)

Pressure Rating:

Static - 300 psi (20 Bar) maximum.
Burst - 1500 psi (100 Bar)

Operating Differential and Close-off: 60 psi maximum (4 bar)

Stem Travel: 0.4 inches (10 mm)

Flow Characteristics: Linear or equal percentage, per Tables 3, 4 and DIP switch setting.

Models:

Actuator: VC7936ZZ11, see Table 1
Bodies (order separately): VCZ..., see Tables 3, 4



Table 1. VC7936 Actuator factory settings.

Model Series	Voltage (50/60 Hz)	Action	Control Signal	Flow Characteristic	Nominal Stroke Timing
VC7936	24 Vac	Direct Acting	0-10 or 2-10 Vdc	Linear	120 seconds. Fail Safe Return:12 seconds

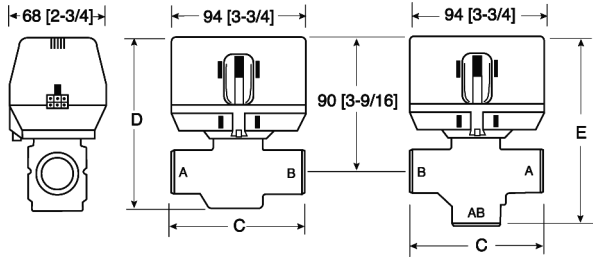

Fig. 1. Nominal dimensions in inches [millimeters].

Table 2. VC Valve Assembled Dimensions.

Dimension [4] Pipe Fitting Sizes	C		D		E	
	mm	inches	mm	inches	mm	inches
1/2" BSPP (int.) [2]	98	3-7/8	111	4-3/8	136	5-11/32
1/2" BSPT (int.)						
3/4" BSPP (int.)	94	3-11/16	113	4-7/16	130	5-1/8
3/4" BSPT (int.)						
3/4" BSPP (ext.)						
22mm Compression [3]	112	4-7/16			140	5-1/2
1" BSPP (int.)	94	3-11/16			136	5-11/32
1" BSPP (ext.)	95	3-11/17	114	4-7/17	137	5-11/33
1" BSPT (int.)	94	3-11/16	113	4-7/16	136	5-11/16
28mm Compression [3]	116	4-9/16			147	5-13/16
North America Standard Models						
3/8" Flare [1]	98	3-7/8	111	4-3/8	136	5-11/32
1/2" Sweat	89	3-1/2			130	5-1/8
1/2" Flare [1]	98	3-7/8			136	5-11/32
1/2" Inverted Flare [1]						
1/2" NPT (int.)						
3/4" NPT (int.)	94	3-11/16	113	4-7/16	130	5-1/8
3/4" Sweat					132	5-3/16
1" NPT (int.)					136	
1" Sweat						5-11/32
1-1/4" Sweat	110	4-5/16	118	4-5/8	142	5-5/8
1-1/4" NPT (int.)						

- [1] No adapters
- [2] Suitable for use as 15 mm compression fitting
- [3] Dimensions shown with nuts and olives installed
- [4] Some models not available in all countries

Table 3. VC Series Valve Bodies: 2-Way Valves.

2-Way Valve Number	Cartridge [5] Pipe Fitting Sizes	1000	1100 [4]	1400	1500	1600	
		Nominal kvs Rating [8]					
VCZAF	1/2" BSPP (int.) [2]	3.0	2.6		0.6	1.1	
VCZAB	1/2" BSPT (int.)		2.9				
VCZAJ	3/4" BSPP (int.)	5.3	4.5	3.3	0.7	1.3	
VCZAK	3/4" BSPT (int.)						
VCZAH	3/4" BSPP (ext.)						
VCZAG	22mm Compression [3]			4.6	3.7		
VCZAP	1" BSPP (int.)	6.0	5.7	3.6	0.7	1.3	
VCZAQ	1" BSPP (ext.)		5.3				
VCZAT	1" BSPT (int.)		5.7				
VCZAN	28mm Compression [3]		5.4				
North America Standard Models			Nominal Cv Rating				
VCZAC	3/8" Flare [1]			2.1			
VCZAA	1/2" Sweat		3.1	2.9	0.7	1.3	
VCZAD	1/2" Flare [1]						
VCZAE	1/2" Inverted Flare [1]		3.2				
VCZBB	1/2" NPT (int.)		3.4	2.9	0.7	1.3	
VCZAL	3/4" NPT (int.)		4.7	3.9	0.8	1.5	
VCZAM	3/4" Sweat		4.6				
VCZAR	1" NPT (int.)		6.6	4.2			
VCZAS	1" Sweat		6.2				
VCZBE	1-1/4" Sweat		7.0				
VCZBD	1-1/4" NPT (int.)						

- [1] No adapters
- [2] Suitable for use as 15 mm compression fitting
- [3] Includes compression nuts and olives
- [4] "1200" series cartridge has the same Cv/kV rating as "1100" series. Suitable for use in potable water applications.
- [5] Model availability is country specific. Some models are not available in all countries
- [6] Can be used for modulating with appropriate software
- [7] Use balancing valve for very low flow on-off applications
- [8] Multiply the kv rating by 1.167 to obtain Cv rating
Example: 2-way, 3/4" BSPT (internally threaded) valve number VCZAJ1400 has a kv rating of 3.9; 3-way 1/2" Sweat valve number VCZMA6100 has a Cv rating of 3.8.

Table 4. VC Series Valve Bodies: 3-Way Valves.

3-Way Valve Number	Cartridge [5] Pipe Fitting Sizes	6000	6100	6400	6500	6600
		Nominal kvs Rating [8]				
VCZME	1/2" BSPP (int.) [2]	3.4	3.2			
VCZMN	1/2" BSPT (int.)		3.3			
VCZMH	3/4" BSPP (int.)	7.0	5.9			
VCZMJ	3/4" BSPT (int.)		5.3			
VCZMG	3/4" BSPP (ext.)	6.9	5.7			
VCZMF	22mm Compression [3]	7.1	5.9			
VCZMP	1" BSPP (int.)	7.7	6.4			
VCZMQ	1" BSPP (ext.)		6.8			
VCZMT	1" BSPT (int.)		6.9			
VCZMM	28mm Compression [3]		6.4			
North America Standard Models		Nominal Cv Rating				
VCZMB	3/8" Flare [1]		2.7			
VCZMA	1/2" Sweat		3.8			
VCZMC	1/2" Flare [1]					
VCZMD	1/2" Inverted Flare [1]		4.2			
VCZNB	1/2" NPT (int.)		3.7			
VCZMK	3/4" NPT (int.)		6.6			
VCZML	3/4" Sweat		5.9			
VCZMR	1" NPT (int.)		8.6			
VCZMS	1" Sweat		6.6			
VCZNE	1-1/4" Sweat		8.6			
VCZND	1-1/4" NPT (int.)					
FLOW CHARACTERISTIC		Quick Open	Linear	Equal Percentage		
APPLICATION		On-Off		[7]		
		[6]	Modulating			

[1] No adapters

[2] Suitable for use as 15 mm compression fitting

[3] Includes compression nuts and olives

[4] "1200" series cartridge has the same Cv/kV rating as "1100" series. Suitable for use in potable water applications.

[5] Model availability is country specific. Some models are not available in all countries

[6] Can be used for modulating with appropriate software

[7] Use balancing valve for very low flow on-off applications

[8] Multiply the kv rating by 1.167 to obtain Cv rating

Example: 2-way, 3/4" BSPT (internally threaded) valve number VCZAJ1400 has a kv rating of 3.9; 3-way 1/2" Sweat valve number VCZMA6100 has a Cv rating of 3.8.

INSTALLATION

When Installing This Product...

1. Read these instructions carefully. Failure to follow them could damage the product.
2. Check the ratings given in the instructions and on the product to make sure the product is suitable for your application.
3. Installer must be a trained, experienced service technician.
4. Always conduct a thorough check-out when installation is completed.
5. While not necessary to remove the actuator from the body, it can be removed for ease of installation. The actuator can be installed in any of the four orientations to suit the most convenient wiring direction. Actuator latching mechanism works only when the lengths of the actuator and the valve body are parallel to each other.
6. An extra 1" (25 mm) head clearance is required to remove the actuator.

IMPORTANT

For trouble-free operation of the product, good installation practice must include initial system flushing, chemical water treatment, and the use of a 50 micron (or finer) system side stream filter(s). The manual lever is used both as a position indicator and as a manual opener to allow initial system flushing. Alternatively, reusable flush caps, part # 272866B, may be purchased separately for use in initial flushing of dirty hydronic systems.

Do not use boiler additives and wetted materials which are petroleum based or contain mineral oil, hydrocarbons, or ethylene glycol acetate. Compounds which can be used, with minimum 50% water dilution, are diethylene glycol, ethylene glycol, and propylene glycol (antifreeze solutions).

PLUMBING

The valve may be plumbed in any angle but preferably not with the actuator below horizontal level of the body. Make sure there is enough room around the actuator for servicing or replacement. Refer to Installation and Instruction sheet 95C-10919 for valve installation instructions.

TO INSTALL ACTUATOR

Installation of a new actuator does not require draining the system, provided the valve body and valve cartridge assembly remain in the pipes. Wiring may be done either before or after the actuator is installed.

1. The actuator head is automatically latched to the valve. Align the coupling hole in the bottom of the actuator with the valve stem. Press the actuator down towards the body with moderate hand force and turn the actuator counter-clockwise by 1/8 turn (45 degrees) to line up the actuator with the piping. The latch will click when engaged. See Fig. 2.

NOTE: The actuator can also be installed at right angles to the valve body but in this position the latch mechanism will not engage.

2. Connect lead wires. See Fig. 3 for flexible conduit installation with plenum-cable models.

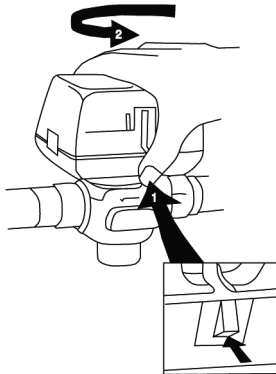

Fig. 2. Latch Mechanism to detach Actuator

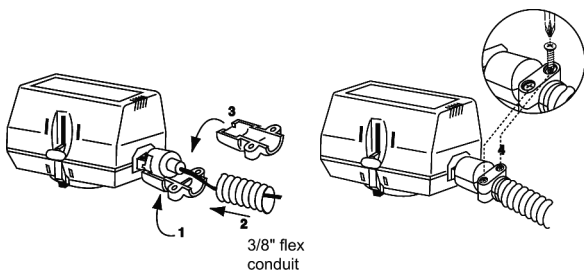

Fig. 3. Flexible Conduit Attachment

WIRING

⚠ CAUTION

1. Disconnect power supply before connecting wiring to prevent electrical shock and equipment damage.
2. Never jumper the supply wires or actuator terminals even temporarily. This may damage the controller.
3. Verify wiring connections of the brown and blue lead wires with respect to the controller. The actuator will not operate if these are wrong. The blue lead must connect to the controller's common terminal when using analog inputs. However, digital inputs are switched from the "hot" side of the controller's power supply.
4. Multiple valves may be connected in parallel to a single controller and transformer, up to the current rating of the controller and transformer.

OPTION SWITCH SETTINGS

The VC7936 has four DIP switches for setting operating characteristics. These are accessible through the slots in the upper part of the case on the end of the actuator with the wiring connections, and may be operated with the tip of a mechanical pencil, or a straightened paper clip. A DIP switch is ON when the switch lever has been moved UP, away from the valve body. They number 1 to 4 from left to right. See Table 5.

Table 5. Dip switch on/off selection for operating characteristics.

DIP Switch	1	2	3	4
ON	↑ REV	0-10V	Equal%	60s
OFF	↓ DIR	Floating	Linear	120s

Sw.1 sets the actuator response.

OFF = direct (normal) operation: A port open with 10 Vdc input (factory setting).

ON = reverse operation, A port closed with 10 Vdc input.

This is useful, for example, for correcting plumbing errors with 3-way valves. This setting affects all control modes.

Sw.2 sets control signal type.

OFF = floating, PWM, or on-off (digital) inputs.

ON = analog voltage modulating input (factory setting).

The VC7936 accepts a variety of control inputs.

Sw.3 sets valve flow characterization.

OFF = linear response, where the stem position is a linear function of the input voltage, and flow is solely a function of the valve body (factory setting).

ON = equal percentage, where the stem position is a 50% equal percent function of input voltage. Equal percentage response improves comfort control during mild weather in heating systems with constant, high temperature supply water, or in chilled water systems in arid desert climates. Please refer to the Resideo Engineering Manual of Automatic Control, publication #77-1100, for a detailed explanation.

Sw.4 sets actuator timing.

OFF = 2 minute end-to-end valve travel (factory setting).

ON = 1 minute travel. The faster response may be needed in lower mass systems.

OPERATION

POWER FAILURE REPOSITION (FAIL SAFE OPERATION)

On a loss of power, the actuator will drive to its stand-by position using energy stored in the super-capacitors, and will resume normal operation on power up. On loss of signal, a VC7936 wired for PFR-Open will open the A port fully. A VC7936 wired for PFR-Close will open the A port fully. The motor can drive the valve through its full stroke in 12 seconds.

PFR position is chosen during installation. In analog mode (DIP switch #2 ON), the white and gray wires are connected to signal common (blue) to fail safe open, or to 24 V (brown) to fail safe closed. In digital mode (DIP switch #2 OFF), the black wire is connected to common (blue) to fail safe open, or to 24 V (brown) to fail safe closed.

The PFR position can be controlled dynamically with a SPST signal by applying 24 V power to the appropriate PFR direction selection lead(s) while power is present. Applying 24 V will cause the valve to close the A port when power is lost. Not applying power will cause the valve to open the A port when power is lost. This can be useful in 2-pipe systems where both hot and chilled water may be used depending on the season, and a different fail safe mode is required for each condition.

Because of the soft close off characteristic of the VC valve, initial (and final) movements of the actuator do not cause significant changes in the valve stem position.

WITH SERIES 70 MODULATING CONTROLLER

Refer to Fig. 4, DIP switch #2 must be ON (factory default).

The controller output may be either 0 to 10 Vdc or 2 to 10 Vdc, but the VC7936 will be closed at 2 V to minimize false control signals caused by induced electrical noise on the wiring.

In direct acting mode (DIP switch #1 off), the valve will be fully closed with a 2 V or lower signal, and fully open with a 10 V signal. In reverse acting mode, 10 V is closed and 2 V is open.

For a 4-20 mA control signal, wire a 499 ohm, 1/2W resistor between the black and blue actuator input leads to develop a 2-10 Vdc signal. If the controller is nearby, the resistor may be installed on the controller's terminal block. See Fig. 5.

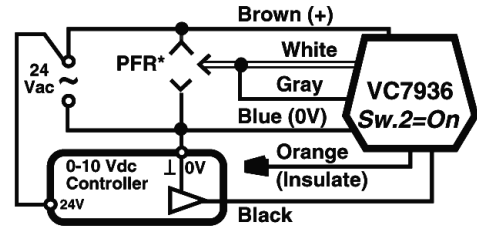

*Valve PFR Position	Connect Wires
Close "port A"	White + Gray + Brown
Open "port A"	White + Gray + Blue

Fig. 4. Wiring Color Code for Cable Models for Modulating (0-10V or 2-10V) Controller.

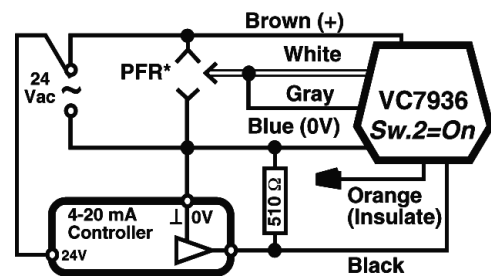

*Valve PFR Position	Connect Wires
Close "port A"	White + Gray + Brown
Open "port A"	White + Gray + Blue

Fig. 5. Wiring Color Code for Cable Models for Modulating (4-20mA) Controller.

WITH SERIES 60 FLOATING (TRISTATE) CONTROLLER

Refer to Fig. 6. DIP switch #2 must be OFF, switch #1 = OFF.

A Series 60 floating controller has SPDT contact closure outputs with a center-off position. On a change in temperature from the set point, the controller will close either the Open or Close contacts creating a momentary voltage pulse on the gray or white input leads, driving the valve to a new position. The pulse must be at least 1/2 second long in order to be detected by the VC7936. The pulse can be held as long as necessary.

For control stability, the stroke time of the actuator while powered has been simulated at either 120 or 60 seconds, depending on DIP switch #4. In fail safe and testing operation, the actuator travels through its stroke in 12 seconds.

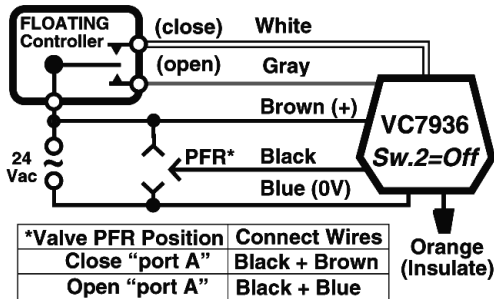

Fig. 6. Wiring Color Code for Cable Models for Floating (Series 60 or "tristate") Controller.

WITH SERIES 70 PWM CONTROLLER
Refer to Fig. 7, DIP switch #2 must be OFF

A Pulse Width Modulating controller has a SPST contact closure output that supplies a repetitive voltage pulse. The duty cycle of the pulse (percentage on time) is proportional to the position of the valve. This control signal was originally developed for use with electromechanical thermal actuators.

If the VC7936 sees the a voltage pulse simultaneously on the gray and white input leads, it automatically interprets this as a PWM signal, and changes the valve to the new position on the second pulse. PWM pulses must be at least 1/2 second long in order to be detected by the VC7936. A 1/2 second pulse is interpreted as an Off signal. The pulse period may be up to 30 seconds, and pulses must be separated by an off period no shorter than 1/2 second. The VC7936 will automatically synchronize to the period of the pulse train.

If DIP switch #1 is on, valve position is proportional to the off time percentage of the pulse train.

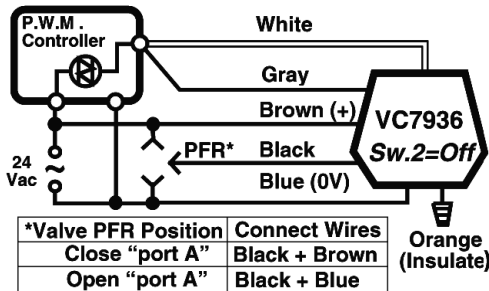

Fig. 7. Wiring Color Code for Cable Models for Pulse Width Modulating (PWM) Controller).

WITH SERIES 80 ON-OFF CONTROLLER

Refer to Fig. 8, DIP switch #2 must be OFF

A Series 80 controller has a SPST contact closure output that supplies 24V power to the controlled device. VC7936 wiring is identical to the PWM installation, above. If a "PWM" pulse extends longer than 30 seconds, the VC7936 interprets this as an on-off control signal, and opens the valve at its 12 second speed. Note that the valve response is delayed by 42 seconds from application of the controller signal. If DIP switch #1 is on, the valve closes when the signal is received.

NOTE: The current draw of the control inputs of the VC7936 is not high enough to operate either a power stealing electronic thermostat, or the anticipator of an electromechanical low voltage thermostat.

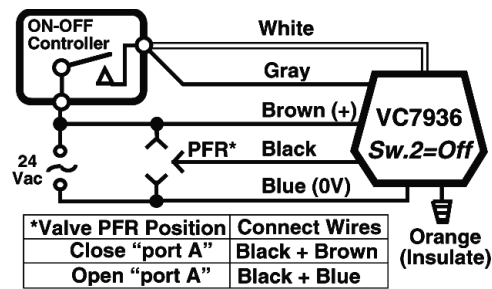

Fig. 8. Wiring Color Code for Cable Models for ON-Off (Series 80) Controller.

START UP

On initial power-up, the capacitors will take about 60 seconds to charge. When ready, the actuator will drive the valve through one full stroke cycle over 24 seconds to calibrate its position, and exercise the valve cartridge. This self-calibration action repeats daily.

CHECK-OUT

1. Raise the set point of the thermostat above room temperature to initiate a call for heat.
2. Observe all control devices - 2 way valve should open. Port A in 3-way valve should open, and port B should close in 90 seconds.
3. Lower the set point of the thermostat below room temperature.
4. Observe the control devices. 2 way valve should close. Port A in 3-way valve should close, and port B should open in 90 seconds.
5. Remove power from actuator. Actuator waits 3 seconds then drives valve to default position, i.e.: open (or closed), in 12 seconds or less.
6. Restore power to actuator. Valve should drive to the position required by the thermostat or controller in 90 seconds or less.

SERVICE

This valve should be serviced by a trained, experienced service technician.

1. If the valve is leaking, drain system OR isolate valve from the system. Do not remove valve body from plumbing.
2. Check to see if the cartridge needs to be replaced.
3. If the motor or other internal parts of the actuator is damaged, replace the entire actuator assembly.

NOTE: Resideo hydronic valves are designed and tested for silent operation in properly designed and installed systems. However, water noises may occur as a result of excessive water velocity. Piping noises may also occur in high temperature (over 212° F [100° C]) systems with insufficient water pressure.

TO REPLACE ACTUATOR

Replacement of an actuator does not require draining the system, provided the valve body and valve cartridge assembly remain in the pipeline.

1. Check replacement part number and voltage ratings for match with old device.
2. Disconnect power supply before servicing to avoid electrical shock or equipment damage.
3. Disconnect leadwires to actuator and remove. Where appropriate, label wires for rewiring.
4. The actuator head is automatically latched to the valve. To remove, press up on the latch mechanism with your thumb. It is located directly below the white manual open lever (see Fig. 2). Simultaneously press the actuator down towards the body with moderate hand force and turn the actuator counter-clockwise by 1/8 turn (45 degrees). Lift the actuator off the valve body.
5. Install the new actuator by reversing the process in (4).
6. Reconnect leadwires.
7. Restore power, and check out operation.



Manufacturer for European Region:
Pittway Sarl, Z.A. La Piece 4,
1180 Rolle, Switzerland

Country of origin: Hungary
95C-10904-06 M.S. Rev. 06-20 | Printed in United States

Manufacturer for North and South America Region:
Resideo Technologies, Inc.
1985 Douglas Drive North, Golden Valley, MN 55422
1-800-468-1502