

REL-iON™ Mission Critical Monitoring System

Kidde Fire Systems' REL-iON™ Mission Critical Monitoring System is a modular sensor platform, designed to detect potential failures in mission critical applications, such as Battery Energy Storage Systems (BESS), Switchgears, Data and Network infrastructure and more.

With an array of over 80 detectors capable of detecting thermal, environmental, power, and mechanical abuses, the REL-iON™ platform delivers real-time data, empowering you to address anomalies proactively, preventing them from escalating into potentially devastating problems.

REL-iON™ key features include:

- **Centralized Control** – One single stand-alone IP-based control unit, the SensorGateway, with built-in temperature sensor and numerous outputs, such as alerting via Simple Network Management Protocol (SNMP) traps, Wi-Fi connectivity, etc.
- **Expandable Modular Design** – SensorHub "Plug-and-Play" units can expand the base control unit capacity up to 12 ports. An Add-On Relay Output Module adds up to 8 outputs and 4 dry-contact inputs.
- **Flexible** – Over 80 detectors and add-on modules, allowing the system to be highly customizable and optimized to detect several different abuse sources and off-gassing events.
- **Easy to Install** – "Plug and Play", Power Over Ethernet (PoE) network architecture, using off-the-shelf RJ45 CAT6/7 cable.
- **Easy to Integrate** – In addition to dry-contact outputs, the system can be configured to be integrated with third-party systems through several different protocols, including Modbus TCP and RTU, and multiple IoT-based platforms.
- **Wide range of applications - Broad opportunity**
 - Battery Energy Storage Systems (BESS)
 - Switchgears
 - Data and Network infrastructure
 - Others

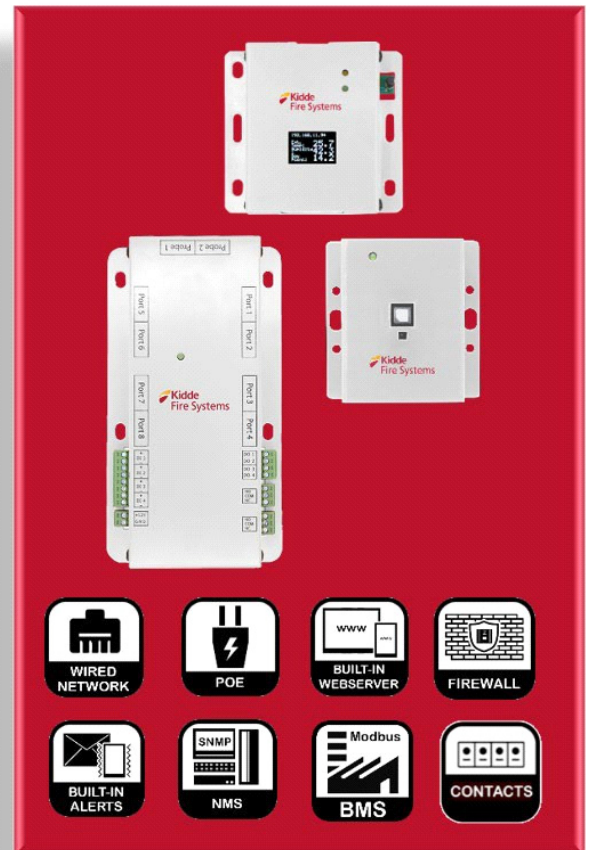

- **Specify and ship worldwide with confidence; globally certified:**

- 17 UL listed sensors *
- CE certified *
- 1 CSFM certification
- 1 ISO listed sensor *

* Where applicable

(Refer to the Regulatory Information table located at the end of this document for information regarding specific sensors.)

Li-ion Batteries - 4 Phases of Failure

In recent years, lithium-ion energy storage systems have become increasingly popular due to their impressive energy density and extended lifespan. Nevertheless, these systems are not without their share of risks, with one significant concern being the potential occurrence of thermal runaway events. Thermal runaway is a situation in which the internal temperature of a lithium-ion battery experiences a rapid increase, resulting in the emission of gases and a subsequent rise in pressure. If left unattended, this process can culminate in explosions or fires.

Stage 1

Stage 1 prevention involves the continuous monitoring of various factors, including environmental conditions, mechanical stress, power fluctuations, and thermal conditions. This monitoring is crucial to proactively prevent potential failures and to optimize the overall lifespan of the battery. Our platform excels in detecting anomalies and guiding you in taking preventative measures to circumvent thermal runaway incidents, ultimately extending the battery's operational lifespan. It's an all-in-one solution meticulously tailored for this stage.

Stage 2

Just before a complete thermal runaway occurs, malfunctioning lithium-ion batteries will vent gases as a result of internal pressure build-up, leading to the rupture of the battery's enclosure. This marks the onset of stage 2.

During this critical phase, you have only a matter of seconds to a few minutes, at most, to react. You may already have one or more battery cells experiencing catastrophic failures, and your primary objective is to contain the spread of a thermal runaway event. Our innovative platform extends off-gas detection beyond just electrolytes' off-gassing, incorporating the analysis of H₂ gas. In several instances of battery failure events, H₂ emerges as the pivotal and most consistent gas signal.

Stages 3 & 4

If a fire occurs, Kidde Fire Systems' smoke detection and clean agent fire suppression solutions are always standing guard to protect your assets for minimum business disruption.

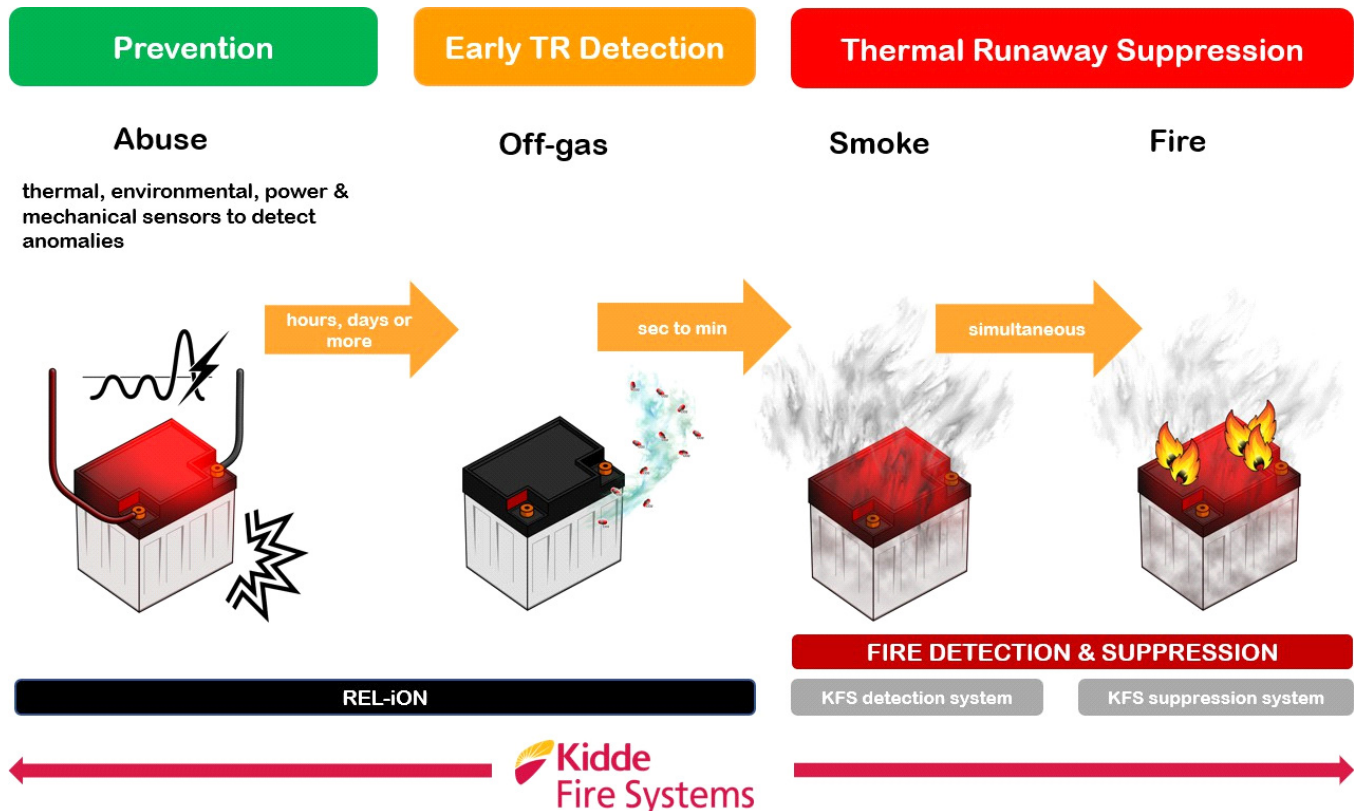

Multi-Point Monitoring Architecture

To mitigate the risk of thermal runaway events, a crucial approach involves the utilization of sensors capable of detecting off-gases or initial venting occurrences. The optimal sensor for this task is one that can discretely identify both volatile organic compounds (VOCs) and Hydrogen (H₂) gases, particularly when employing liquid cooled batteries. In such cases, battery failure can occur at typical operating temperatures, releasing H₂ gas before any other gas.

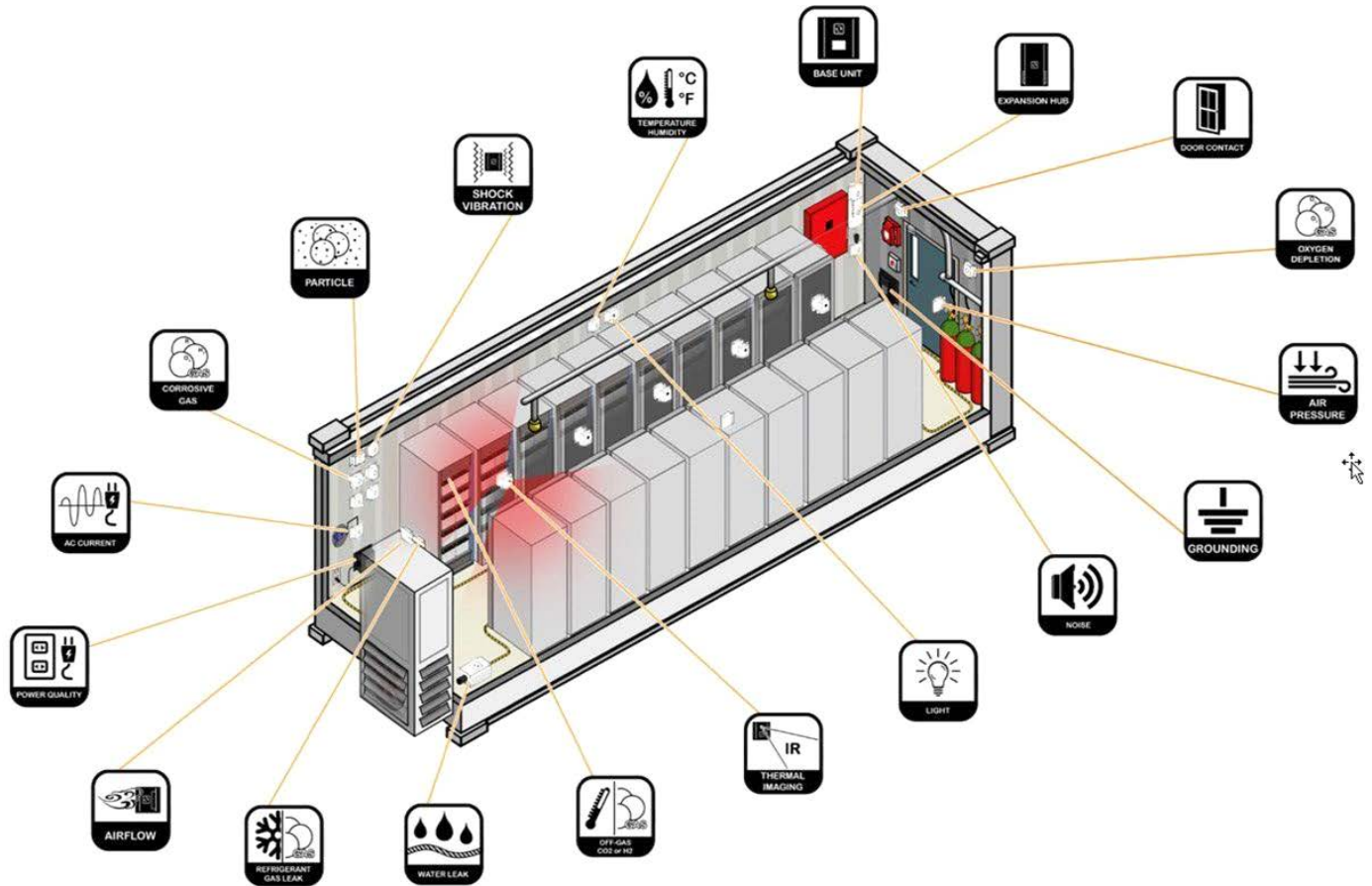

NOTE:

To ensure operation of REL-iON's latest (enhanced) components and sensors, firmware version 9.3.1 is required for the 31-BASE-WIRED and 31-BASE-PI-5-24V SensorGateways (or firmware version 1.0.1 for the 31-BASE-IND-6). **Check the firmware version currently installed on your SensorGateway base unit to determine if you need to upgrade.**

The latest firmware is available for download on the Kidde Fire Systems Distributor Extranet site (www.kiddefiresystems.com). Select *Firmware Upgrade Software* and type "REL-iON" in the search box. Select and download the firmware file to your computer.

Refer to "Updating The Firmware of the SensorGateway" in Chapter 1 of the REL-iON Monitoring System Design, Installation, Operation and Maintenance Manual (P/N 06-238003-001) for instructions on how to check the current firmware version in use and how to install a new version. This DIOM manual is also available on the Kidde Fire Systems Distributor Extranet site.

SensorGateway (31-BASE-WIRED)

The Sensor Gateway is a stand-alone IP based temperature sensor with built-in alerting features and serves as the base unit for our solution.

Key Features:

- Onboard temperature sensor
- Built-in web server
- DHCP or static IP
- 0U and DIN mountable
- No Internet connectivity required to operate
- Stand-alone device: no software needed
- Fully responsive web interface for desktop, tablet, or smart phone
- User configurable firewall for enhanced security
- Industrial grade: UL Listed, FCC and CE certified



Technical Specifications:

TCP/IP	IPv4 at 10/100 Mbps.
Power Source	PoE: IEEE 802.3af or 31-BASE-PWR (Optional AC power adapter) or 31-BASE-PWR-USB (USB power adapter)
Power Usage	1500mW (without sensors attached)
Certification	UL 62368
Network Data Transfer	SNMP GET (50 - 130 bytes), SNMP Trap (143 - 280 bytes)
Built-in:	Web server (JSON and XML), SNMP v1, v2 and v3 (MD5/AES), Modbus TCP.
Built-in alerting options:	SNMP Traps
External sensor probes:	2 sensor probes through straight RJ45 CAT6/7 cable with max distance of 100m or 330ft
Max distance to switch:	CAT6/CAT7 up to 100m / 300ft.
Temperature Resolution:	0.1°C / 0.18°F
Temperature Reading:	-55°C to +125°C (-67°F to +257°F)
Temperature Accuracy:	± 1°C (± 2°F) over 0°C to +75°C
Operating temperature range	0°C to +75° C (32°F to +167°F)
Humidity (operating and storage)	< 90% rH (non-condensing)
Dimensions	95 mm (3.7") x 88 mm (3.4") x 21 mm (0.8")
Weight	0.21 kg (0.46 lbs)

SensorGateway (31-BASE-IND-6)

The 31-BASE-IND-6 is an updated version of the Base Unit that includes new built-in features, **such as RS485** on a terminal block with 1 dry contact output. It boasts a data memory of QSPI 256Mbit and allows for the insertion of an SD Card. Additionally, it includes two status LEDs on the PCB. **IMPORTANT NOTE: Not all REL-ION sensors are supported by the 31-BASE-IND-6. Please check with the Kidde Fire Systems product manager before purchasing the 31-BASE-IND-6.**

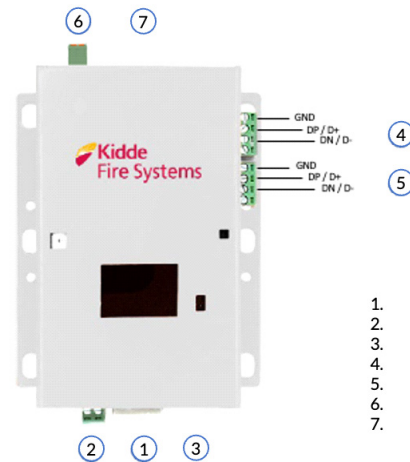

1. LAN/PoE(30W)
2. 24VDC via terminal blk
3. 12VDC power input
4. Modbus RTU (RS485)
5. Modbus RTU (RS485)
6. 1x Relay Out
7. 2x RJ45 terminals

Technical Specifications:

TCP/IP	IPv4 at 10/100 Mbps
Power Source	PoE: IEEE 802.3af or 31-BASE-PWR (Optional AC power adapter) or 31-BASE-PWR-USB (USB power adapter)
Power Usage	684 mW (without sensors attached)
Network Data Transfer	SNMP GET (SO - 130 bytes), SNMP Trap (143 - 280 bytes)
Network protocol	DHCP or status IPv4
Built-in:	Web server, SNMP v2 and v3 (MDS/AES), Mod bus TCP
Max daisy chain sensors	60
Built-in alerting options:	2G B of on-board data (sensor) logging
Relay contact outputs	1
Storage	2G B of on-board data (sensor) logging
Connectivity	RJ45 cable transmitting data and power from Base Unit to Sensor
Humidity (operating and storage)	< 90% rH (non-condensating)
Operating temperature range	-25°C to+ 70°C (13° F to +158° F)
Temperature Accuracy:	± 1°C (± 2°F) over 0°C to +75°C
Operating temperature range	0°C to +75° C (32°F to +167°F)
Sensor enclosure	Steel enclosure, industrial grade
Dimensions	84.6mm (3.33") x 104.4mm (4.11") x 29.6mm (1.17")
Weight	211g (0.47lbs)
Industrial IP protocols	SNMP, Modbus RTU, Modbus TCP, TLS, (HTTPS), MQTT
Mounting option	OU rack, DIN rail, magnetic, or wall mountable sensor

SensorGateway (31-BASE-PI-5-24V)

Compared to the regular base unit, the BASE-PI-5-24V is equipped with a terminal block for power connections, offering a more secure and industrial-grade alternative to the traditional barrel jack. This design enhances its suitability for industrial environments where reliability and robustness are essential. This Base Unit seamlessly supports all sensors, enabling real-time environmental and infrastructure monitoring for comprehensive facility management.



1. PoE (15W)
2. 24 VDC via the terminal block
3. 2 RJ45 terminals

Technical Specifications:

TCP/IP	IPv4 at 10/100 Mbps.
Network data transfer	SNMP GET (50 - 130 bytes) , SNMP Trap (143 - 280 bytes)
Built-in	Web server, SNMP v2 and v3 (MD5/AES), Modbus TCP
Network protocol	DHCP or status IP
Powered by	It is powered via PoE or/and through a 12v DC to 24v DC input via the terminal block
Connectivity	RJ45 cable transmitting data and power from Base Unit to Sensor
Power usage	684 mW (without sensors attached)
Industrial protocols	SNMP and Modbus TCP Modbus RTU with ADDON
Max daisy chain sensors	25
Operating temperature range	0°C to +75°C (32°F to +167°F)
Humidity (operating and storage)	< 90% rH (non-condensating)
Sensor enclosure	Steel enclosure, industrial grade
Mounting option	0U rack, DIN rail, magnetic, or wall mountable sensor
Dimensions	97mm (3.82") x 88mm (3.46") x 22mm (0.87")
Weight	189.8g (0.42lbs)

SensorHub - 8 Ports Hub (31-EXP-8HUB)

Expands the base unit from 2 to 8 ports and adds control capabilities.

Key Features:

- Plugs into the base unit w/ max length of 1m (31-BASE-WIRED)
- Powered by the base unit (31-BASE-WIRED)
- 4 dry contact outputs and 2 relay outputs for automatic control
- Max 1 expansion hub per base unit

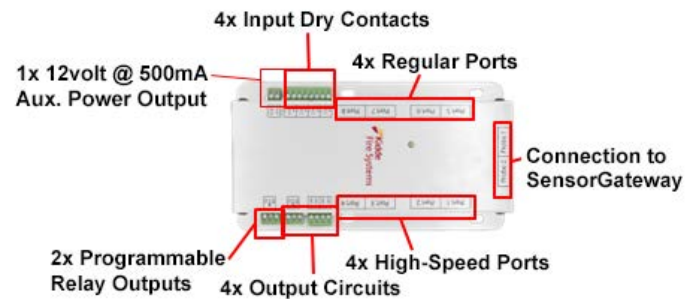
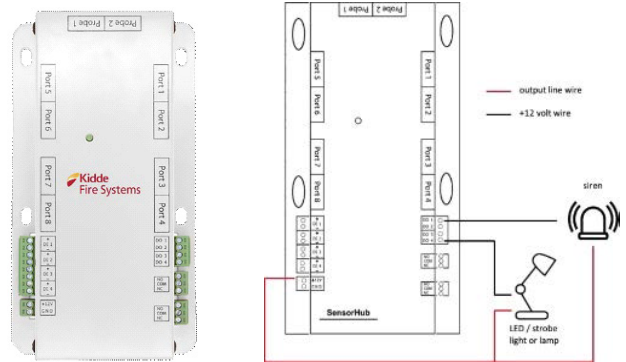

Technical Specifications:

Power Source	SensorGateway (31-BASE-WIRED)
Certification	UL 62368
Power Usage	588mW
Expansion ports for external sensor probes	8
Dry contact input ports	4
Dry contact output ports	4 (digital sink 100mA)
Relay outputs	2 (400VAC/150VDC and 200VA/192W)
Auxiliary supply	maximum current capacity of 500mA at 9 to 12 VDC
Temperature Resolution:	0.1°C / 0.18°F
Operating temperature range	0°C to +75°C (32°F to +167°F)
Humidity (operating and storage)	< 90% rH (non-condensing)
Dimensions	165mm (6.5") x 95mm (3.7") x 22mm (0.8")
Weight	0.57 kgs (1.26 lbs.)

Sensorhub - 12 Ports Hub (31-EXP-12HUB)

Expands the base unit from 2 to 12 ports, with integrated Daisy Starter functionality. **IMPORTANT NOTE: Use of 31-EXP-12HUB requires firmware version 9.3.1 or greater.**



Technical Specifications:

Expansion ports for external sensor probes	12
Power Usage	235 mW
Powered by and communicates with	Base Unit (31-BASE-XX) (required), Max 1 expansion hub per Base Unit
Auxillary power input	+12V to +24V power input
Auxillary power output	+12V
Connectivity	RJ45 cable transmitting data and power from Base Unit to Sensor
Cable specification	RJ45 CAT 6/7 recommended
Humidity (operating and storage)	< 90% rH (non- condensing)
Operating temperature range	0°C to +75°C (32°F to +167°F)
Mounting option	0U rack, DIN rail, magnetic, or wall mountable sensor
Dimensions	212mm (8.35") x 36.5mm (1.44") x 95mm (3.74")
Weight	558.8g (1.23lb)

Relay Output Module 8 Ports (31-ADDON-8RELAY)

Designed to offer an additional 8 relay outputs and 4 dry contact inputs, this module is also equipped to detect malfunctioning relays, ensuring enhanced functionality and reliability. **IMPORTANT NOTE: Use of ADDON-8RELAY requires firmware version 9.3.1 or greater.**



Technical Specifications:

Connectivity	RJ45 cable transmitting data and power from Base Unit to Sensor
Power Usage	240 to 2100 mW
Powered by and communicates with	Base Unit (31-BASE-XX) (required), Max 1 per Base Unit
Cable specification	RJ45 CAT 6/7 recommended Up to 100m (330ft) subject to cable quality and interference
Relay outputs	8
Dry contact input	4 Triggering options: Relay / NPN or N-channel mosfet / Open Drain / Open Collector
Relay contact rating	125V AC 0.5A 30V DC 1A
Humidity (operating and storage)	< 90% rH (non- condensing)
Operating temperature range	0°C to +75°C (32°F to +167°F)
Mounting option	0U rack, DIN rail, magnetic, or wall mountable sensor
Dimensions	96.2mm (3.79") x 152.2mm (5.99") x 30.5mm (1.20")
Sensor enclosure	Steel enclosure, industrial grade
Weight	365.2g (0.81lb)

Panel Sensor (31-R-EDG-PANEL)

Our Panel Sensor has been designed for early detection of anomalies inside automation and electrical panels. By monitoring factors like VOCs, NOx, CO, smoke, temperature, and humidity—which are signs of overheating, insulation breakdown, or component failure—it can potentially alert you before minor issues escalate into catastrophic failures.

IMPORTANT NOTE: The 31-R-EDG-PANEL sensor is NOT a life safety or fire safety device and should NOT be used as such. It is specifically designed to detect anomalies in electrical and automation panels only.

IMPORTANT NOTE: Use of 31-R-EDG-PANEL requires firmware version 9.3.1 or greater.

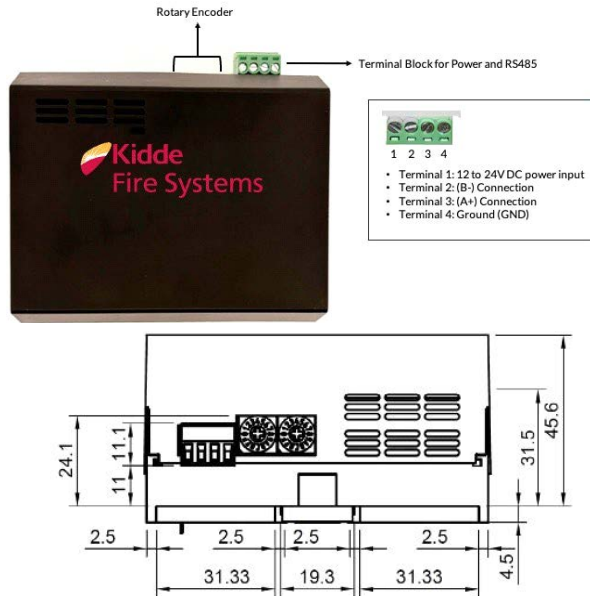

Technical Specifications:

CO measurement range	0-5000 ppm
CO max detecting concentration	5000 ppm
VOC measurement range	0-500 VOC index points
VOC repeatability	<±5 VOC index points
NOx measurement output	0-500 NOx index points
NOx repeatability	<±5 NOx index points
Smoke detection	Photometric
Input Voltage	12-24V DC (when using RS-485) or powered by 31-BASE-XX
Power rating	0.4-4.4W
Protocol	Modbus RTU over RS485 Integration with 31-BASE-XX over RJ45 (serial data)
Default Modbus communication settings	1200 bps, No Parity, 1 Stop Bit
Cable specification	RJ45 CAT 6/7 recommended Up to 100m (330ft) subject to cable quality and interference
Operating temperature range	-10°C to +50°C (-23°F to +10°F)
Humidity (operating and storage)	< 90% RH (non-condensating)
Sensor enclosure	Plastic industrial grade enclosure
Mounting option	DIN rail
Dimensions	75 mm (2.95") x 46 mm (1.81") x 90.1mm (3.55")

Flammable Gas Sensor (31-R-GAS-FLAMMABLE)

This is a calibration-free Flammable Gas Sensor that is specifically designed to detect the presence and measure the concentration of specific gases in nonhazardous critical facilities. The sensor's RS485 address may be set by the user (with 254 addresses available). **IMPORTANT NOTE: Use of all the available features of the 31-RGAS-FLAMMABLE sensor requires the firmware version 4.33 or later on the unit itself and firmware 9.3.1 or greater.**

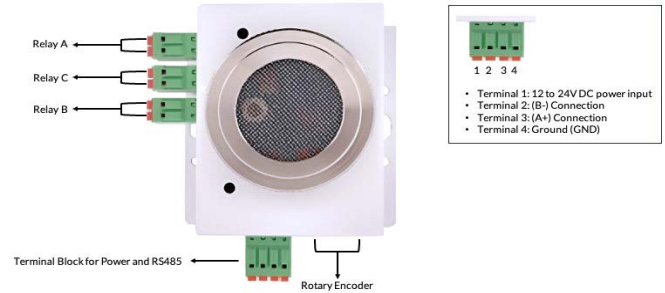

Technical Specifications:

Certification	UL 2075, CSFM cert 5275-2414:0001 CE, EMC EN61010 compliant IEC 61000-4-4:2004, IEC 61000-4-6, IEC 61000-4-5, IEC 60068-2-6:2010 and IEC 60068-2-30
Internal temp. measurement range	-40°C to 125°C
Internal temperature accuracy	±0.48°C (0.86 °F)
Internal relative humidity measurement range	0 to 100% RH
Internal relative humidity accuracy	2% RH
VOC measurement output range	0-500 VOC Index
VOC repeatability	<±5 VOC index points or % mass volume (m.v.)
Butane (C4H10) accuracy	±5 %LEL
Ethane (C2H6) accuracy	±5 %LEL
Hydrogen (H2) accuracy	±5% LEL
Isobutane (CH3) accuracy	±5 %LEL
Methane (CH4) accuracy	±5 %LEL
Octane (C8H18) accuracy	±12 %LEL
Pentane (C5H12) accuracy	±5 %LEL
Propane (C3H8) accuracy	±6 %LEL
Propylene (C3H6) accuracy	±5 %LEL
Toluene (C7H8) accuracy	±12 %LEL
Xylene (C8H10) accuracy	±12 %LEL
Response time (T90)	<30s
Detection Range	0-100 %LEL
Detection method	Spectrometer
Relay outputs	3 (Normally Open)
Relay switching current	up to 0.5A
Input Voltage	12-24V DC
Power usage	672mW
Protocol	Stand-alone: Modbus RTU over RS485 only. Need Modbus TCP, must connect to a base unit.
Life span	up to 15 years
Operating temperature range	-40°C to 75°C (-40°F to 167°F)
Humidity (operating and storage)	0 to 100% RH (non-condensating)
Operating temperature range	-40°C to +70°C (-40°F to +158°F)
Humidity (operating and storage)	0 to 100% RH (non-condensating)
Sensor enclosure	Steel enclosure, industrial grade
Mounting option	0U rack, DIN rail, magnetic, or wall mountable sensor
Dimensions	71mm (2.79") x 70.5mm (2.77") x 30 mm (1.18")
Weight	193g (0.43lbs)

VOC, Humidity and Temperature Off-Gas Sensor (31-OEM-STD-OFFGAS-LITE)

The Off-Gas Sensor monitors off-gas in battery systems including Volatile Organic Compound (VOC), Temperature and Humidity.



Key Features:

- Powered by the base unit (31-BASE-WIRED)
- Compact "Plug-and-Play" sensor
- 0U rack or wall mountable
- Steel enclosure, industrial grade
- Alerts via SNMP Traps
- Also available as a daisy chained version (31-OEM- DAISY-OFFGAS-LITE)
- Requires the 31-BASE-FW-SSLS firmware add-on for the 31-BASE-WIRED

Technical Specifications:

Power Source	SensorGateway (31-BASE-WIRED)
Power Usage	360 mW
Certification	UL Listing 61010 ISO17025 certified for temperature sensor
VOC measurement output range	0 – 500 VOC Index
VOC repeatability	<±5 VOC index points
Temperature measurement range	- 40°C to 125°C
Temperature accuracy	± 0.48 °C
Relative humidity measurement range	0 to 100 % RH
Relative humidity accuracy	2 %RH
Life Span	min 10 years
Operating temperature range	-30°C to +70°C (-22°F to +94°F)
Humidity (operating and storage)	< 90% rH (non-condensing)
Dimensions	72.96 mm (2.87") x 68.8 mm (2.7") x 29.41 mm (1.16")
Weight	0.13kg (0.29 lbs)
Maximum length of daisy chain (for daisy chain model)	10 sensors per base unit within 100m/330ft of total length Longer distances possible with optional 31-DAISY-BOOSTER

IR Spot Temperature Sensors (31-ENV-IRSPOT-XX and 31-DAISY-THIMG-IRSPOT-XX)

This industrial digital SNMP and Modbus TCP Sensor is designed for contactless temperature monitoring inside enclosures. The sensor returns the average temperature of everything within its field of view.



Key Features:

- Plugs into the base unit (31-BASE-WIRED)
- Powered by the base unit (31-BASE-WIRED)
- Compact "Plug-and-Play" sensor
- Can be 0U rack, din rail, magnetic, or wall mounted
- Steel enclosure, industrial grade
- Single zone contactless temperature sensor
- Reports average temperature from objects within its FoV
- Only 1 IP address required for every daisy chain
- Can connect up to 48 DAISY-IRSPOT sensors per daisy chain

Technical Specifications:

Power Source	SensorGateway (31-BASE-WIRED), power adapter 12V 2A is required for more than 10 Sensors
Power Usage	60 mW
Field Of View (FOV)	90°
Temperature accuracy	±0.5°C/ ±0.9°F accuracy from 0°C-50°C / 32°F to 122°F
Resolution	0.02 °C / 32.036°F
Temperature reading	-70°C to +380°C (-94°F to +716°F) in PoE mode
Reading unit	in Celsius or Fahrenheit
Operating temperature range	0°C to +75°C (32°F to +167°F)
Humidity (operating and storage)	< 90% rH (non-condensing)
Dimensions	71 mm (2.8") x 68 mm (2.7") x 23 mm (0.9")
Maximum length of ENV-IRSPOT daisy chain	48 sensors per base unit within 100m/330ft cable length Longer distances possible with optional 31-DAISY-BOOSTER
Weight	0.12kg (0.26 lbs)

**Thermal Image Sensor Large - 160*120
(31-ENV-THIMG-L)**

These Large Thermal Image Sensors provide the temperature of detected objects and equipment. The world's first SNMP and Modbus thermal camera sensor that tells you the temperature of what it sees. 19200 temperature measurement points in one image, analyzed every 2 seconds. Minimum and maximum temperature data is available to industrial and IT automation platforms via Modbus TCP or SNMP.

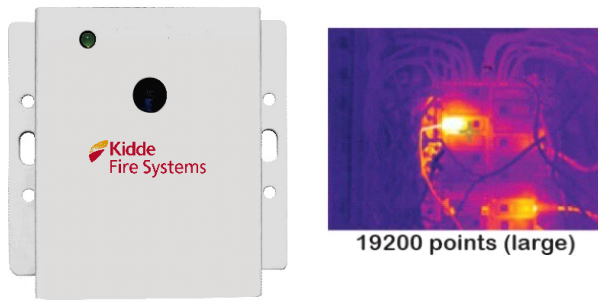

**Thermal Image Sensor Medium - 80*60
(31-ENV-THIMG-M)**

These Medium Thermal Image Sensors provide the temperature of detected objects and equipment. The world's first SNMP and Modbus thermal camera sensor that tells you the temperature of what it sees. 4800 temperature measurement points in one image, analyzed every 2 seconds. Minimum and maximum temperature data is available to industrial and IT automation platforms via Modbus TCP or SNMP.

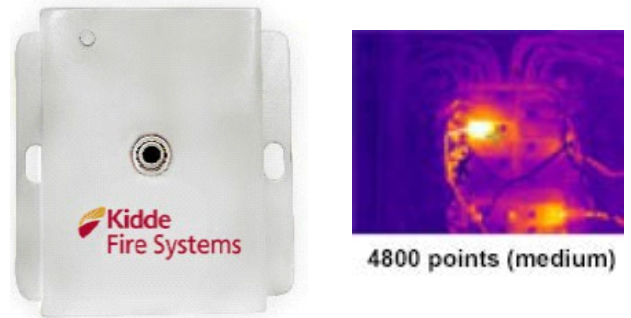

Key Features:

- Powered by the base unit (31-BASE-WIRED)
- 0U rack or wall mountable
- Readings in Celsius or Fahrenheit
- Can detect object temperature from -10°C to 450°C
- Up to 5 thermal camera sensors supported per SensorHub
- Outputs minimum and maximum temperatures per zone (Can add up to 4 zones.)
- Requires the 31-BASE-FW-SSLS firmware add-on for the 31-BASE-WIRED

Key Features:

- Powered by the base unit (31-BASE-WIRED)
- 0U rack or wall mountable
- Readings in Celsius or Fahrenheit
- Can detect object temperature from -40°C to 300°C
- Up to 5 thermal camera sensors supported per SensorHub
- Outputs minimum and maximum temperatures per zone (Can add up to 4 zones.)
- Requires the 31-BASE-FW-SSLS firmware add-on for the 31-BASE-WIRED

Technical Specifications:

Power Source	SensorGateway (31-BASE-WIRED)
Power Usage	492 mW
Certification	UL 62368
Scene dynamic range	High gain mode (lower temperature): -10°C to 140°C (14°F to 284°F) Low gain mode (higher temperature): -10°C to 450°C (14°F to 842°F)
Temperature accuracy	High gain mode (lower temperature): ± 5°C or 5% Low gain mode (higher temperature): ± 10°C or 10%
Field of View (FoV)	56° horizontal(narrow) 71° diagonal
Resolution	160x120 pixels
Operating temperature range	-10°C to +65°C (14°F to +149°F)
Humidity (operating and storage)	< 90% rH (non-condensing)
Dimensions	71.5 mm (2.8") x 68 mm (2.7") x 23 mm (0.9")
Weight	0.112kg (0.25 lbs)

Technical Specifications:

Power Source	SensorGateway (31-BASE-WIRED)
Power Usage	492 mW
Certification	UL 62368
Scene dynamic range	High gain mode (lower temperature): -10°C to 140°C (14°F to 284°F) Low gain mode (higher temperature): -10°C to 450°C (14°F to 842°F)
Temperature accuracy	High gain mode(lower temperature): ± 5° C or 5% Low gain mode(higher temperature): ± 10° C or 10%
Field of View (FoV)	51° horizontal(narrow) 63° diagonal
Resolution	80x60 pixels
Operating temperature range	-10°C to +65°C (14°F to 149°F)
Humidity (operating and storage)	< 90% rH (non-condensing)
Dimensions	71.5 mm (2.8") x 68 mm (2.7") x 23 mm (0.9")
Weight	0.112kg (0.25 lbs)

**Thermal Image Sensor Extra-Small - 16*12
(31-ENV-THIMG-XS)**

These Extra-Small Thermal Image Sensors provide the temperature of detected objects and equipment. The world's first SNMP and Modbus thermal camera sensor that tells you the temperature of what it sees with 192 temperature measurement points in one image, analyzed every 2 seconds. Minimum and maximum temperature data is available to industrial and IT automation platforms via Modbus TCP or SNMP.

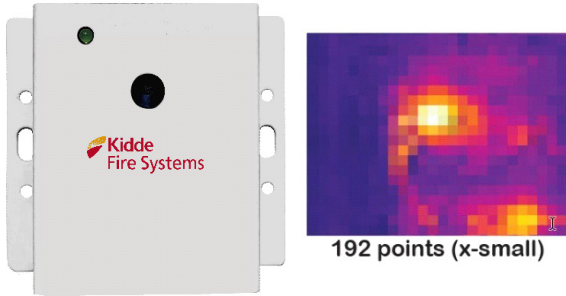

Key Features:

- Powered by the base unit (31-BASE-WIRED)
- 0U rack or wall mountable
- Readings in Celsius or Fahrenheit
- Can detect object temperature from -40°C to 300°C
- Up to 5 thermal camera sensors supported (by connecting to SensorHub)
- Outputs minimum and maximum temperatures per zone (Can add up to 4 zones.)
- Requires the 31-BASE-FW-SSLS firmware add-on for the 31-BASE-WIRED

Technical Specifications:

Power Source	SensorGateway (31-BASE-WIRED)
Power Usage	492 mW
Scene dynamic range	-40°C to 300°C (-40°F to 572°F)
Certification	UL 62368
Temperature accuracy	± 1.5°C (± 1.8°F)
Field of View (FoV)	110° horizontal(wide) 75° vertical
Resolution	16 x 12 pixels
Operating temperature range	-10°C to +85°C (14°F to +185°F)
Humidity (operating and storage)	< 90% rH (non-condensing)
Dimensions	71.5 mm (2.8") x 68 mm (2.7") x 23 mm (0.9")
Weight	0.112kg (0.25 lbs)

**Thermal Image Sensor Small - 32*24
(31-ENV-THIMG-S)**

A regular temperature sensor provides the temperature of the air surrounding the sensor. These Small Thermal Image Sensors provide the temperature of detected objects and equipment. The world's first SNMP and Modbus thermal camera sensor that tells you the temperature of what it sees with 768 temperature measurement points in one image, analyzed every 2 seconds. Minimum and maximum temperature data is available to industrial and IT automation platforms via Modbus TCP or SNMP.

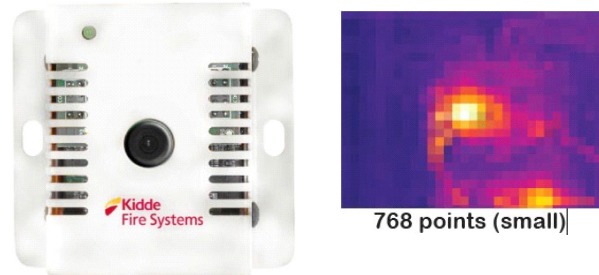

Key Features:

- Plugs into the base unit (31-BASE-WIRED)
- Powered by the base unit (31-BASE-WIRED)
- Can be 0U rack, din rail, magnetic, or wall mounted
- Reading in Celcius or Fahrenheit
- Can detect object temperature from -40°C to 300°C
- Up to 5 thermal camera sensors supported (by connecting to SensorHub)
- Outputs maximum temperature per zone (Can add up to 4 zones.)

Technical Specifications:

Power Source	SensorGateway (31-BASE-WIRED)
Power Usage	492 mW
Certification	UL 62368
Target temperature range	-40 °C to 300 °C (-40 °F to 572 °F)
Temperature accuracy	± 1.5°C / 34.7°F
Field of View (FoV)	110° horizontal(wide) 75° vertical
Resolution	32x24 pixels
Operating temperature range	-10°C to +85°C (14°F to +185°F)
Humidity (operating and storage)	< 90% rH (non-condensing)
Dimensions	71.5 mm (2.8") x 68 mm (2.7") x 23 mm (0.9")
Weight	0.112kg (0.25 lbs)

Thermal Image Sensor Small Cylindrical- 32*24 (31-ENV-THIMG-CS)

The THIMG-SC is a compact Thermal Image Sensor designed for switchgear, offering a comprehensive solution to monitor all bus bars with its 768 discrete temperature measurement points and 4 reporting zones. It's mountable inside switchgear or onto existing IR windows, UL 61010 recognized, and integrates seamlessly via Modbus TCP or SNMP. Optionally available as an RS-485 sensor for direct integration with PLC and other systems, it provides flexible deployment options for efficient monitoring.

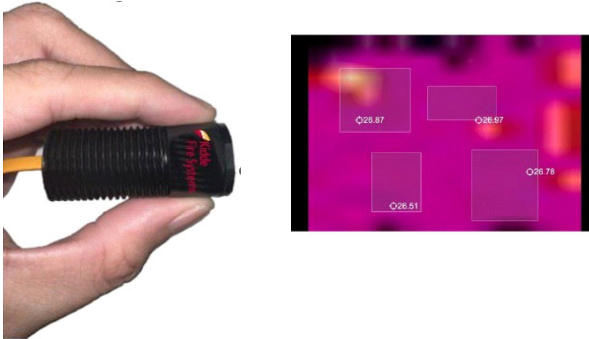

Technical Specifications:

Powered by and communicates with	Base Unit (31-BASE-XX) (required) Requires the optional 31-BASE-FW-SLS firmware add on for the Base Unit
Connectivity	RJ45 cable transmitting data and power from Base Unit to Sensor
Cable specification	RJ45 CAT 6/7 recommended Up to 100m (330ft) subject to cable quality and interference
Sensor power usage	492 mW
Target temperature range	-40°C to 300°C (-40°F to 572°F)
Temperature accuracy	±1°C (±1.8°F)
Field of View (FoV)	110° horizontal (wide) 75° vertical
Max object distance	Up to 5m
Resolution	32x24 pixels
Operating temperature range	-10°C to +85°C (14°F to 185°F)
Humidity (operating and storage)	< 90% rH (non-condensating)
Sensor enclosure	Plastic material enclosure
Mounting option	Secure mounting with bolt and nut mechanism Can be mounted using two M24 nut
Dimensions	L: 51.8mm (2.04") W: 24mm (0.94") Ø: 24
Weight	32.9g (0.071lbs)

Water Leak Sensor WITHOUT cables (31-ENV-LEAK)

Designed to monitor water leaks or the presence of water inside your critical facility.



Key Features:

- Powered by the base unit (31-BASE-WIRED)
- Alerts via SNMP Traps or voice calls
- Expandable up to 200m/656ft per sensor
- The sensing cables are resistant to corrosion and abrasion
- Reusable sensing cable
- Triggers an alert within 1-2 seconds when water touches the sensing cable
- Sensing cables are approved for installation in ordinary and hazardous areas

Technical Specifications:

Power Source	SensorGateway (31-BASE-WIRED)
Power Usage	364 mW
Water Detection Response	1 – 2 seconds
Resetting time	Cable dries and resets within 5 seconds of removal from standing water
Cable cleaning method	Wipe with clean damp cloth
Cable breaking strength (Including connectors)	70lbs/32kg
Data Output	Provides a WET/DRY indication in SensorGateway
Operating temperature range	0°C to + 75°C (32°F to +167°F)
Sensor Housing Material and cable gland protection rating	IP68
Dimensions	65mm (2.56") x 95mm (3.74") x 55mm (2.17")
Weight	0.17kg (0.37 lbs)

Sensing Cables purchased separately:

- 65ft/ 20m water detection cable (31-ENV-WLEAK-20M)
- 16ft / 5m water detection cable (31-ENV-WLEAK-5M)
- 16ft / 5m battery acid detection cable (31-ENV-BLEAK-5M)
- 16ft / 5m fuel detection cable (31-ENV-FLEAK-5M)

Particle Sensor (31-ENV-PARTICLE)

Designed to provide added value to applications in several industries, including air quality monitoring, air purifiers and HVAC.



Key Features:

- Powered by the base unit (31-BASE-WIRED)
- 0U Rack or wall mountable sensor
- Alerts via SNMP Traps or voice calls
- Measures total mass concentration values for PM1, PM2.5, PM4 and PM10 in $\mu\text{g}/\text{m}^3$
- MCERTS-Certified

Technical Specifications:

Power Source	SensorGateway (31-BASE-WIRED)
Power Usage	156 mW
Mass concentration range:	0 – 1000 $\mu\text{g}/\text{m}^3$
Particle detection size range:	Mass concentration: PM1.0, PM2.5, PM4 and PM10 Number concentration: PM0.5, PM1.0, PM2.5, PM4 and PM10
Mass concentration precision:	PM1 and PM2.5: $\pm 10 \mu\text{g}/\text{m}^3 @ 0$ to 100 $\mu\text{g}/\text{m}^3$ $\pm 10\% @ 100$ to 1000 $\mu\text{g}/\text{m}^3$ PM4 and PM10: $\pm 25 \mu\text{g}/\text{m}^3 @ 0$ to 100 $\mu\text{g}/\text{m}^3$ $\pm 25\% @ 100$ to 1000 $\mu\text{g}/\text{m}^3$
Maximum long-term mass concentration precision limit drift:	$\pm 1.25 \mu\text{g}/\text{m}^3 @ 0$ to 100 $\mu\text{g}/\text{m}^3$ $\pm 1.25\% @ 100$ to 1000 $\mu\text{g}/\text{m}^3$
Lower limit detection:	0.3 μm
Lifetime:	10 years operating 24hrs/day
Acoustic emission level:	25dB(A) @ 0.2m
Long term acoustic emission level drift:	+0.5dB(A)/year @ 0.2m
Sampling interval:	1 \pm 0.04s
Operating temperature range	-10°C to 60°C (14°F to 140°F) in PoE mode
Storage temperature range:	-40°C to 70°C (-40°F to 158°F)
Humidity (operating and storage)	< 90% rH (non-condensing)
Recommended temperature and humidity range:	10°C to 40°C and 20% to 80% rH
Dimensions	88.8mm (3.5") x 51mm (2") x 32.5mm (1.28")
Weight	0.14kg (0.31 lbs)

Ground Sensor (31-PWR-GROUND)

The Grounding Monitoring system connects to your facilities or site electrical ground system for continuous monitoring of the grounding's resistance.

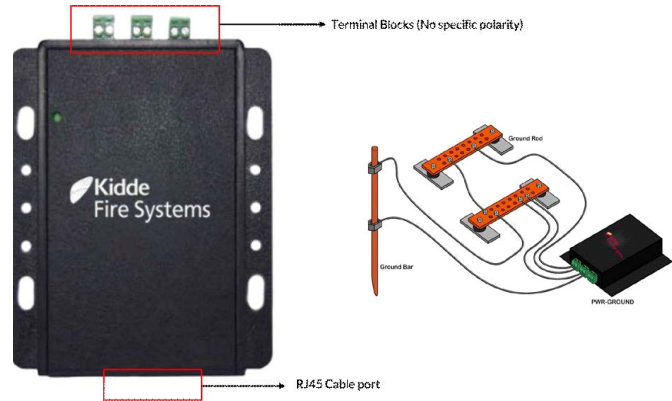

Key Features:

- Powered by the base unit (31-BASE-WIRED)
- 0U Rack or wall mountable sensor
- Monitors up to 3 different ground systems
- Measures resistance in Ohms
- Terminal connectors for wires from 26 up to 16 AWG (solid/stranded)

Technical Specifications:

Power Source	SensorGateway (31-BASE-WIRED)
Power Usage	36 mW
Range:	0 to 5000 Ohms
Injected current	0.7 mA
Ground metering points	3 different ground terminals
IO isolation	1000 V AC
Operating temperature range	0°C to +75°C (32°F to +167°F)
Humidity (operating and storage)	< 90% rH (non-condensing)
Dimensions	107 mm (4.2") x 90 mm (3.5") x 26 mm (1.02")
Weight	0.117 kg (0.26 lbs)

Atmospheric Corrosion Sensor (31-ENV-CORROSION)

This non-intrusive “Plug and Play” corrosion sensor empowers OEMs in mission-critical industries to effectively monitor and manage corrosion levels, allowing them to maintain the performance, reliability, and safety of their equipment and infrastructure.



Key Features:

- Powered by the base unit (31-BASE-WIRED)
- 0U Rack or wall mountable sensor
- Alerts via SNMP Traps or voice calls
- Design based on ANSI / ISA 71.04-2013 standard

Technical Specifications:

Power Source	SensorGateway (31-BASE-WIRED)															
Power Usage	260 mW															
Corrosion measurement range (Copper):	<table border="1"> <tr> <td>Category</td> <td>Severity</td> <td>Copper</td> </tr> <tr> <td>G1</td> <td>Mild</td> <td><300 Å</td> </tr> <tr> <td>G2</td> <td>Moderate</td> <td><1,000 Å</td> </tr> <tr> <td>G3</td> <td>Harsh</td> <td><2,000 Å</td> </tr> <tr> <td>GX</td> <td>Severe</td> <td>>2,000 Å</td> </tr> </table>	Category	Severity	Copper	G1	Mild	<300 Å	G2	Moderate	<1,000 Å	G3	Harsh	<2,000 Å	GX	Severe	>2,000 Å
Category	Severity	Copper														
G1	Mild	<300 Å														
G2	Moderate	<1,000 Å														
G3	Harsh	<2,000 Å														
GX	Severe	>2,000 Å														
Corrosion measurement range (Silver):	<table border="1"> <tr> <td>Category</td> <td>Severity</td> <td>Silver</td> </tr> <tr> <td>G1</td> <td>Mild</td> <td><200 Å</td> </tr> <tr> <td>G2</td> <td>Moderate</td> <td><1,000 Å</td> </tr> <tr> <td>G3</td> <td>Harsh</td> <td><2,000 Å</td> </tr> <tr> <td>GX</td> <td>Severe</td> <td>>2,000 Å</td> </tr> </table>	Category	Severity	Silver	G1	Mild	<200 Å	G2	Moderate	<1,000 Å	G3	Harsh	<2,000 Å	GX	Severe	>2,000 Å
Category	Severity	Silver														
G1	Mild	<200 Å														
G2	Moderate	<1,000 Å														
G3	Harsh	<2,000 Å														
GX	Severe	>2,000 Å														
Operating temperature range	0°C to +75°C (32°F to +167°F)															
Humidity (operating and storage)	< 90% rH (non-condensing)															
Dimensions	72.96 mm (2.87") x 68.8 mm (2.7") x 29.41 mm (1.16")															
Weight	0.13 kg (0.29 lbs)															

Daisy Chain Starter (31-DAISY-STARTER)

The 31-DAISY-STARTER connects the daisy chain sensors to the base unit.



Key Features:

- Powered by the base unit (31-BASE-WIRED)
- 0U Rack or wall mountable sensor
- Steel enclosure, industrial grade
- Alerts via SNMP Traps or voice calls
- Up to 1x DAISY-STARTER per base unit
- Allows the connection of up to 48 daisy-chained sensors, depending on the sensor type
- Displays number of daisy chain sensors connected

Technical Specifications:

Power Source	SensorGateway (31-BASE-WIRED), power adapter 12V 2A is required for more than 10 Sensors
Power Usage	288 mW
Certification	UR 61010
Operating temperature range	0°C to +75°C (32°F to +167°F)
Humidity (operating and storage)	< 90% rH (non-condensing)
Dimensions	73 mm (2.9") x 68 mm (2.7") x 23 mm (0.9")
Weight	0.11 kg (0.25 lbs)

Daisy Chained – Temp & Humidity (31-DAISY-THUM)

Designed for monitoring temperature and humidity levels inside data centers, server rooms, cabinets and other critical facilities.



Key Features:

- Plugs into the base unit (31-BASE-WIRED)
- Powered by the base unit (31-BASE-WIRED)
- Compact "Plug-and-Play" sensor
- Can be 0U rack, din rail, magnetic, or wall mounted
- Steel enclosure, industrial grade
- Alerts via SNMP Traps or voice calls
- Optional calibration certificates available
- Can connect up to 20 DAISY-THUM Sensors

Requirements:

- Plugs into the base unit (31-BASE-WIRED)
- The 31-DAISY-STARTER is required (as it serves as the controller for the daisy-chained sensors.)

Technical Specifications:

Power Source	SensorGateway (31-BASE-WIRED) power adapter 12V 2A is required for more than 10 Sensors
Power Usage	120 mW
Temperature resolution	0.1°C (0.18)°F precision
Temperature accuracy	+/- 0.5°C (+/- 32.9 °F) from -10°C to +85°C / 14°F to 185°F
Temperature reading	-55°C to +125°C (-67°F to +257°F)
Relative humidity measurement range	0 to 100 % RH
Relative humidity accuracy	+/- 2 % RH between 10 % RH to 90 % RH and +/- 4 % RH below 10 % RH and above 90 % RH
Humidity (operating and storage)	< 90% rH (non- condensing)
Operating temperature range	0°C to +75°C (32°F to +167°F)
Dimensions	68 mm (2.68") x 72 mm (2.83") x 28 mm (1.10")
Weight	0.12kg (0.26 lbs)
Maximum length of ENV-TEMP daisy chain	Up to 20 sensors per base unit within 100m/330ft of total length Longer distances possible with optional 31-DAISY-BOOSTER

Daisy Chain Voltage Booster (31-DAISY-BOOSTER)

The DAISY-BOOSTER extends the operating length of the daisy chain sensors from 100 meters up to 200 meters.



Key Features:

- 0U rack or wall mountable
- Steel enclosure, industrial grade
- Connects to any daisy chain sensor
- Extends the daisy chain distance from 100m up to 200m
- Includes LED to indicate optimal placement of DAISY- BOOSTER

Technical Specifications:

Power Source	Daisy chain sensor
Power Usage	300 mW
Voltage output	12 V
Humidity (operating and storage)	< 90% RH (non- condensing)
Operating temperature range	0°C to +85°C (32°F to +185°F)
Dimensions	74 mm (2.9") x 68 mm (2.7") x 23 mm (0.9")
Temperature Accuracy	+/- 0.5°C (+/- 0.9 °F) from -10°C to +85°C / 14°F to 185°F
Weight	0.12kg (0.26 lbs.)

Daisy Chained - VOC, Humidity and Temperature Off- Gas Sensor (31-DAISY-GAS-VOC)

The Off-Gas Sensor is designed for monitoring off-gas in battery systems. Measures CO2, Volatile Organic Compound (VOC), and Temperature.



Key Features:

- Plugs into the base unit (31-BASE-WIRED)
- Certificate: UL61010 (Recognized)
- Compact "Plug-and-Play" sensor
- 0U rack or wall mountable
- Steel enclosure, industrial grade
- CO2 measurement of 0-40,000ppm
- VOC measurement of 0-500 VOC Index
- Temperature measurement of -10°C – 60°C

Technical Specifications:

Power Source	SensorGateway (31-BASE-WIRED) power adapter 12V 2A is required for more than 10 Sensors
Certification	UR61010 - UL Recognized
Power Usage	100 mW
CO2 output range	0-40,000 ppm
CO2 measurement accuracy	± 40 ppm
CO2 repeatability	± 10 ppm
VOC measurement output range	0-500 VOC Index
VOC repeatability	<±5 VOC index points or % mass volume(m.v.)
Temperature measurement range	- 10°C – 60°C
Temperature accuracy	± 0.8 °C(15 °C–35 °C) ± 1.5 °C(-10 °C–60 °C)
Temperature repeatability	± 0.1°C
Operating temperature range	0°C to +75°C (32°F to +167°F)
Humidity (operating and storage)	< 90% rH (non- condensing).
Dimensions	71.1 mm (2.8") x 68.8 mm (2.7") x 28.8mm (1.1")
Weight	0.12kg (0.26 lbs.)
Maximum length of daisy chain	16 sensors per base unit within 100m/330ft of total length, longer distances possible with optional 31-DAISY- BOOSTER

Temperature Sensor (31-ENV-TEMP)

This temperature sensor is designed for indoor use inside data centers, server rooms and cabinets.



Key Features:

- Plugs into the base unit (31-BASE-WIRED)
- Powered by the base unit (31-BASE-WIRED)
- Compact "Plug-and-Play" sensor
- 0U rack or wall mountable
- Steel enclosure, industrial grade
- Alerts via SNMP Traps or voice calls
- Optional calibration certificates available

Technical Specifications:

Power Source	SensorGateway (31-BASE-WIRED)
Power Usage	60 mW
Operating temperature range	0°C to +75°C (32°F to +167°F)
Humidity (operating and storage)	< 90% rH (non- condensing)
Dimensions	71.5 mm (2.8") x 68 mm (2.68") x 23 mm (0.9")
Temperature Resolution	0.1°C (0.18)°F precision
Temperature Accuracy	+/- 0.5°C (+/- 0.9 °F) from -10°C to +85°C / 14 °F to 185°F
Weight	0.12kg (0.26 lbs.)
Reading Unit	in Celsius or Fahrenheit
Temperature Reading	-55°C to +125°C (-67°F to +257°F)

Digital Airflow Sensor Probe (31-ENV-AIRFLOW)

ServersCheck introduces one of the first standalone digital Airflow Sensors for data centers. The sensors measure air-speed in meters per second and report it as such to the base unit, the SensorGateway. (Requires SensorGateway v5.1+ with firmware greater than 8.0.0.)



Key Features:

- Plugs into the base unit (31-BASE-WIRED)
- Powered by the base unit (31-BASE-WIRED)
- 0U Rack or wall mountable sensor
- Measures air speeds of up to 3m/s
- Air speed equivalent of up to 6.7 mph or 10.8 kmh
- Alerts via SNMP Traps or voice calls

Technical Specifications:

Power Source	SensorGateway (31-BASE-WIRED)
Power Usage	84 mW
Operating temperature range	-10°C to +65°C (14°F to +149°F) in PoE mode
Humidity (operating and storage)	< 90% rH (non- condensing).
Dimensions	71.5 mm (2.8") x 68 mm (2.68") x 23 mm (0.9")
Accuracy	± 5%
Flow Polling Rate	minimum of 1 second
Air Mass Flow Range	0m/s to 3m/s (up to 6.7 mph or 10.8 kmh)
Weight	0.13kg (0.29 lbs.)

Differential Air Pressure Sensor with Built-In Temperature Sensor (31-ENV-AIRPRESSURE)

The Differential Air Pressure Sensor, designed in the USA, monitors differential air pressure and air temperature in data centers, server rooms, healthcare facilities and other critical facilities.



Key Features:

- Plugs into the base unit (31-BASE-WIRED)
- Powered by the base unit (31-BASE-WIRED)
- 0U Rack or wall mountable sensor
- Alerts via SNMP Traps or voice calls
- Pressure and temperature sensors made in Switzerland
- Measures air pressure in Pa (Pascal)
- Pressure range of -500 to +500 Pa
- Pressure accuracy of 0.5 Pa
- Temperature range of -45C to +85C with a 0.1C resolution and a ±0.5°C (0.9 °F) accuracy

Technical Specifications:

Power Source	SensorGateway (31-BASE-WIRED)
Power Usage	96 mW
Operating temperature range	-10°C to +65°C (14°F to +149°F) in PoE mode
Humidity (operating and storage)	< 90% rH (non- condensing).
Dimensions	71.5 mm (2.8") x 68 mm (2.68") x 23 mm (0.9")
Weight	0.13kg (0.29 lbs.)
Accuracy	0.5 Pa
Air Pressure Range	-500 to + 500 Pa
Flow polling rate	min 1 second

Indoor Dust Particle Sensor Probe (31-ENV-DUST)

The Indoor Dust Particle Sensor monitor dusts particles in data centers, server rooms and cabinets.



Key Features:

- Plugs into the base unit (31-BASE-WIRED)
- Powered by the base unit (31-BASE-WIRED)
- 0U Rack or wall mountable sensor
- Alerts via SNMP Traps or voice calls
- Compact and affordable optical dust sensor made in Japan
- Reports dust density in mg/m^3
- Range: 0 to $600 \mu\text{g}/\text{m}^3$
- Measures total dust density (PM2.5 and PM10 combined)
- Sensitivity: $100 \mu\text{g}/\text{m}^3$

Technical Specifications:

Power Source	SensorGateway (31-BASE-WIRED)
Power Usage	156 mW
Certification	UR 61010
Operating temperature range	0°C to +75°C (32°F to +167°F) in PoE mode
Humidity (operating and storage)	< 90% rH (non- condensing).
Dimensions	71.5 mm (2.8") x 68 mm (2.68") x 23 mm (0.9")
Weight	0.14kg (0.31 lbs.)
Range:	0 – $600 \mu\text{g}/\text{m}^3$
Sensitivity:	$100 \mu\text{g}/\text{m}^3$
Measurement mechanism:	Optical

Air Quality Sensor VOC and NOx (31-ENV-AIRQUALITY)

This Air Quality Sensor is designed to monitor off-gas in battery systems. Measures CO₂, Volatile Organic Compound (VOC), Temperature and Humidity.



Technical Specifications:

CO ₂ output range	0 – 40,000 ppm
CO ₂ measurement accuracy	± 40 ppm
Certification	UL Listing UR 61010
CO ₂ repeatability	± 10 ppm
VOC measurement output range	0 – 500 VOC Index
VOC repeatability	<±5 VOC index points or % mass volume(m.v.)
Temperature measurement range	- 10°C – 60°C
Temperature accuracy	± 0.8 °C(1.44°F) accuracy from 15 °C – 35 °C (27 °F – 63 °F)
Relative humidity measurement range	0 to 100 % RH
Relative humidity accuracy	15 °C – 35 °C, 20 %RH – 65 %RH = ±6 %RH
Powered and communicates with	Base Unit (31-BASE-XX) (required) Requires the optional 31-BASE-FW-SLS firmware add on for the Base Unit
Connectivity	RJ45 cable transmitting data & power from Base Unit to Sensor
Cable specification	RJ45 CAT 6/7 recommended Up to 100m (330ft) subject to cable quality & interference
Sensor power usage	405 mW
Operating temperature range	0°C to 50°C (32°F to 122°F)
Humidity (operating and storage)	< 90% rH (non- condensing)
Sensor enclosure	Steel enclosure, industrial grade
Mounting option	0U rack, DIN rail, magnetic, or wall mountable sensor
Dimensions	71.1 mm (2.8") x 68.8 mm (2.7") x 28.8mm (1.1")
Weight	130g (0.29 lb)

Optical Oil Leak Sensor (31-ENV-LEAK-OPTICAL-H)

The Optical Leak Sensor is a contactless, reusable sensor which detects the presence of hydrocarbon in liquid form on surfaces.

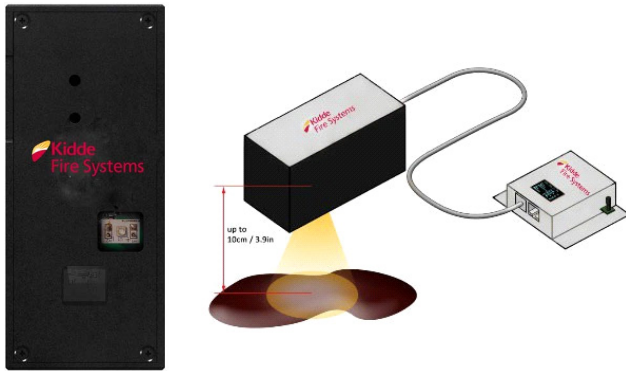

Key Features:

- Plugs into the base unit (31-BASE-WIRED)
- Powered by the base unit (31-BASE-WIRED)
- Alerts via SNMP Traps or voice calls
- Monitors hydrocarbon leaks via optical sensing
- With calibration option for detection of surface area
- Reusable sensor
- Wall, floor or ceiling mount

Technical Specifications:

Power source	SensorGateway (31-BASE-WIRED)
Power usage	2.1W
Data output	Provides a WET/DRY indication in SensorGateway
Maximum height from surface	10 cm
Detection time	3 seconds
Operating temperature range	0°C to +75°C (32°F to +167°F)
Humidity (operating and storage)	< 90% rH (non- condensing)
Sensor housing	Black plastic IP65 rated enclosure
Dimensions	146 mm (5.7") x 63 mm (2.5") x 60.89 mm (2.4")
Weight	0.57kg (1.26 lbs)

Temperature and Humidity Sensor (31-ENV-THUM)

The Temperature and Humidity Sensor is designed to monitor temperature and humidity levels inside data centers, server rooms, cabinets and other critical facilities.



Key Features:

- Plugs into the base unit (31-BASE-WIRED)
- Powered by the base unit (31-BASE-WIRED)
- Compact "Plug-and-Play" sensor
- 0U rack or wall mountable
- Steel enclosure, industrial grade
- Alerts via SNMP Traps or voice calls
- Optional calibration certificates available
- Humidity probe made in Switzerland

Technical Specifications:

Power Source	SensorGateway (31-BASE-WIRED)
Certification	UR 61010
Power Usage	60 mW
Temperature Resolution	0.1°C (0.18)°F precision
Temperature Accuracy	+/- 0.5°C (+/- 0.9 °F) from -10°C to +85°C / 14°F to 185°F
Temperature Reading	-55°C to +125°C (-67°F to +257°F)
Reading Unit	in Celsius or Fahrenheit
Relative Humidity Range	0 to 100 % RH.
Relative Humidity Resolution or Precision	0.1 % RH and 1% RH
Relative Humidity Accuracy	+/- 2 % RH between 10 % RH to 90 % RH and +/- 4 % RH below 10 % RH and above 90 % RH.
Relative Humidity Long Term Stability	< 1 % RH/year.
Operating temperature range	0°C to +75°C (32°F to +167°F)
Humidity (operating and storage)	< 90% rH (non-condensating)
Dimensions	71.5 mm (2.8") x 68 mm (2.68") x 23 mm (0.9")
Weight	0.12kg (0.26 lbs.)

Stainless Steel Temperature Sensor (-55C +125C) (31-ENV-TSTAIN)

The stainless steel temperature monitoring probe was designed to monitor temperature in areas where the other ServersCheck's sensors cannot be used.



Key Features:

- Plugs into the base unit (31-BASE-WIRED)
- Powered by the base unit (31-BASE-WIRED)
- Compact "Plug-and-Play" sensor
- IP68 rated for outdoor use
- Alerts via SNMP Traps or voice calls
- Optional calibration certificates available

Technical Specifications:

Power Source	SensorGateway (31-BASE-WIRED)
Power Usage	60 mW
Temperature Resolution	0.1°C (0.18)°F precision
Readings	Celsius or Fahrenheit
Temperature Resolution	0.1°C (0.18)°F precision
Temperature Accuracy	+/- 0.5°C (+/- 0.9 °F) from 0°C to +85°C (32 °F to 185 °F) / +/- 1°C(33.8 °F) for other ranges
Temperature Reading	-55°C to +125°C (-67°F to +257°F)
Operating temperature range	4°C to 65°C (39F to 148F)
Humidity (operating and storage)	< 90% rH (non-condensating).
Sensor Housing Material	IP 65 plastic housing
RJ45 cable Gland protection rating	IP 68
Dimensions	65 mm (2.5") x 95 mm (3.74") x 55 mm (2.16")
Weight	0.12 kg (0.26 lbs.)

Surface Temperature Sensor (31-ENV-TSURFACE)

This industrial digital SNMP and Modbus TCP sensor is designed to monitor temperature while attached to a cable or pipe.



Key Features:

- Plugs into the base unit (31-BASE-WIRED)
- Powered by the base unit (31-BASE-WIRED).
- Measures surface temperatures from -55°C to +125°C
- Resolution: 0.1°C
- With a ±0.5°C accuracy in the range -10°C to +85°C
- Plastic enclosure for safety
- Attached to cable via zip tie or hose clamp
- 0U Rack or wall mountable sensor
- Alerts via SNMP Traps or voice calls
- 2m/6ft sensor cable to sensor enclosure

Technical Specifications:

Power Source	SensorGateway (31-BASE-WIRED)
Power Usage	60 mW
Temperature Resolution	0.1°C (0.18)°F precision
Temperature Accuracy	+/- 0.5°C (+/- 0.9 °F) from 0°C to +85°C / +/- 1°C for other ranges
Temperature Reading	-55°C to +125°C (-67°F to +257°F)
Operating temperature range	0°C to +75°C (32°F to +167°F)
Sensor Housing Material & RJ45 cable gland protection rating	IP 68
Dimensions	65 mm (2.5") x 95 mm (3.74") x 55mm (2.16").
Weight	0.57 kgs (1.26 lbs.)
Probe dimensions	50 mm long with Stainless steel probe with 1.82 m (6 ft.) long, high-temp silicone rubber cable

**Ultra Low Temperature Sensor (-200C to +550C)
(31-ENV-TULTRA)**

This Ultra Low Temperature Sensor monitors temperature in applications where our traditional temperature sensors cannot be used. With its IP65 rated enclosure and stainless steel protected platinum wired sensor, this sensor can be used in extreme low temperature environments of up to almost -200° Celsius or 73° Kelvin.



Key Features:

- Plugs into the base unit (31-BASE-WIRED)
- Powered by the base unit (31-BASE-WIRED)
- Compact "Plug-and-Play" sensor
- Alerts via SNMP Traps
- Integrates over IP using Modbus TCP, SNMP, XML, JSON with other systems
- Integrates over RS-485 using Modbus RTU with ICS. Requires optional add-on
- IP65 electronics enclosure
- 30-50mm stainless steel protection for platinum sensor
- 2m Teflon cable between sensor and electronics enclosure

Technical Specifications:

Power Source	SensorGateway (31-BASE-WIRED)
Power Usage	60 mW
Temperature Precision	0.1°C (0.18)°F precision
Temperature Accuracy	-196°C to +75°C -320°F to +167°F 77°K to 348°K
Operating temperature range for stainless steel sensor head and cable	-196°C to +75°C -320°F to +167°F 77°K to 348°K
Operating temperature range for IP65 Sensor Box	4°C to 65°C (39°F to 148°F)
Humidity (operating and storage)	< 90% rH (non-condensating).
Sensor Housing Material	IP 65 plastic housing
RJ45 cable Gland protection rating	IP 68
Dimensions	65 mm (2.5") x 95 mm (3.74") x 55mm (2.16")

**AC Current Sensor Probe max 100A (110-240v)
(31-PWR-AC-CUR)**

Is a piece of equipment running or not? How is it running? The AC Current Sensor Probe enables you to determine the state of legacy equipment based on the equipment's current (power) usage. Integrates with SNMP and Modbus TCP into your monitoring systems.



Key Features:

- Plugs into the base unit (31-BASE-WIRED)
- Powered by the base unit (31-BASE-WIRED)
- Non-intrusive "Plug-and-Play" current sensor
- Put clamp around power cable and start monitoring
- Designed for equipment up to 100A

Technical Specifications:

Power Source	SensorGateway (31-BASE-WIRED)
Power Usage	384 mW
Input Current	0-100A AC
Non-linearity:	+/- 3%
Resistance Grade	B
Readings	A (Ampere)
Split Core Certification:	CE, RoHS.
Operating temperature range	0°C to +75°C (32°F to +167°F) in PoE mode.
Humidity (operating and storage)	< 90% rH (non-condensating)
Dimensions	74 mm (2.9") x 66 mm (2.59") x 22mm (0.8")
Weight	0.4kg (0.88 lbs.)

AC Power Failure Sensor Probe (110v-240v) (31-PWR-AC-FAIL)

The Power Failure Sensor Probe from ServersCheck enables alerts if the mains power goes out. The sensor comes with an external power adapter that is plugged into the main power line. The sensor itself has to be powered by a UPS system so that it still can send alerts in the event of a mains power outage. By default, alerts are sent by the sensor through the base unit via SNMP Traps. The sensor can also be configured to safely shutdown servers in the event of a detected power failure.

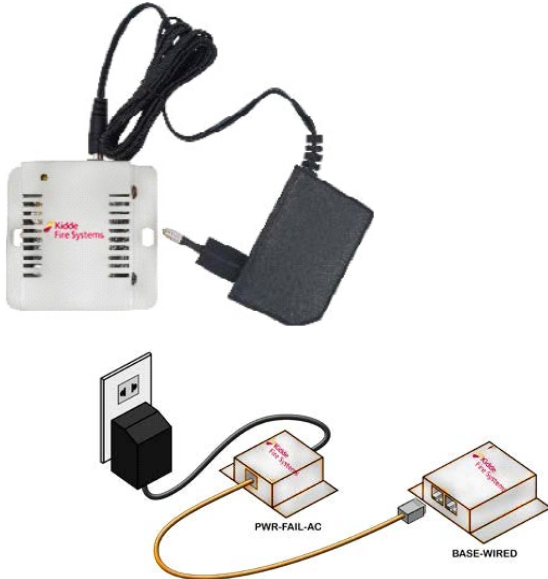

Key Features:

- Plugs into the base unit (31-BASE-WIRED)
- Powered by the base unit (31-BASE-WIRED)
- Provides an ON/OFF indication to the gateway
- AC Power Adapter for sensing main power status

Technical Specifications:

Power Source	SensorGateway (31-BASE-WIRED)
Power Usage	216 mW
Power Adapter Style	EU, UK or US
Power adapter Specs	Input : Autoswitching 90-240 VAC/47-63 Hz Output: 9 VDC, 1.5 A, 2m cord terminated with 2.1mm (center positive) plug
Operating temperature range	-40°C to +75°C (40°F to +167°F)
Humidity (operating and storage)	< 90% rH (non-condensating).
Dimensions	74 mm (2.9") x 66 mm (2.59") x 22mm (0.8")
Weight	0.24kg (0.53 lbs.)

Water Spot Sensor (31-ENV-WSPOT)

The Water Spot Sensor is used in applications where the water leak sensor cannot be deployed. The Spot Sensor detects water from the location where it is placed (when water contacts the two rods).

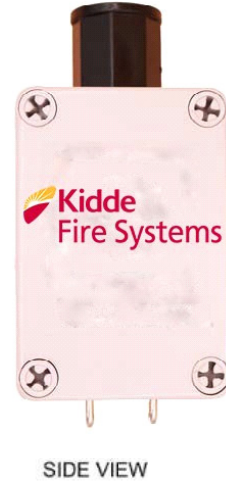

Key Features:

- Plugs into the base unit (31-BASE-WIRED)
- Powered by the base unit (31-BASE-WIRED)
- Alerts via SNMP Traps
- Triggers an alert when water makes contact to the two rods
- Typically used in applications to monitor if water does not reach a certain level

Technical Specifications:

Power Source	SensorGateway (31-BASE-WIRED)
Power Usage	288 mW
Trigger	2 metal rods must make contact with water to trigger sensor
Standard cleaning method	Wipe with clean damp cloth
Data Output	Provides a WET/DRY indication in SensorGateway
Operating temperature range	0°C to +75°C (32°F to +167°F)
Sensor Housing Material & RJ45 cable gland protection rating	Housing is rated IP65 Plastic / RJ45 Gland is rated IP68
Dimensions	65 mm (2.5") x 95 mm (3.74") x 55mm (2.16")
Weight	0.57 kgs (1.26 lbs.)

Input/Output Sensor Probe, Dry Contact, 6 IN & 4 OUT (31-IND-IO)

The Input/Output Sensor includes 16 dry contact inputs and 4 dry contact outputs. The ServersCheck Dry Contact (voltage free contact) Sensor monitors the state of any electrical dry contact output enabled device and can control equipment using one of its four outputs. Examples of such devices are alarms, generators, control relays, valves, fans, HVAC etc.

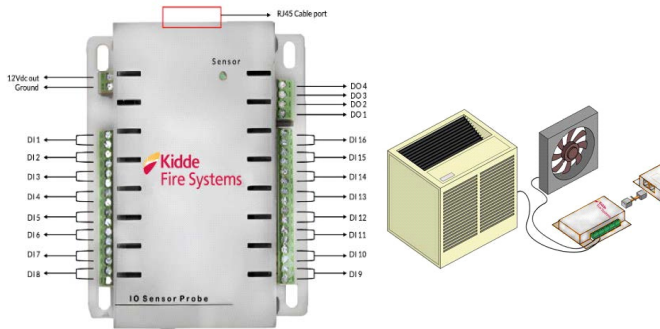

Key Features:

- Plugs into the base unit (31-BASE-WIRED)
- Powered by the base unit (31-BASE-WIRED)
- 16 distinct dry contact inputs
- Not only can you define the normal state, but you can also set a minimum time that a state should be in before triggering an alarm
- Can be configured (on a per port basis) to monitor either a Normal Open (N.O.) or Normal Closed (N.C.) state
- On top of the 16 inputs, the device also features four outputs. With the outputs, you can control equipment. (For example you could remotely or automatically start a backup air conditioning unit, start a pump when a water leak is detected.)
- 1 I/O sensor probe per gateway / Does not work with an expansion hub

Technical Specifications:

Power Source	SensorGateway (31-BASE-WIRED)
Power Usage	371 mW
Dry contact inputs	16
Dry contact outputs	4
Power output	12 VDC power out to power attached devices (for example smoke, motion, door sensors) - max 700mA
Contact polling rate	min 1 second
Operating temperature range	0°C to +75°C (32°F to +167°F)
Operating humidity range	< 90% rH (non-condensating)
Weight	0.24 kgs (0.53lbs.)
Dimensions	107 mm (4.2") x 95 mm (3.7") x 29mm (1.4")

AC Power Quality Sensor (110v-240v) (31-PWR-AC-QUAL)

The AC Power Quality Sensor monitors single phase power quality in your critical facilities and edge infrastructure sites. Designed to provide you an insight of your power quality at your power's edge.

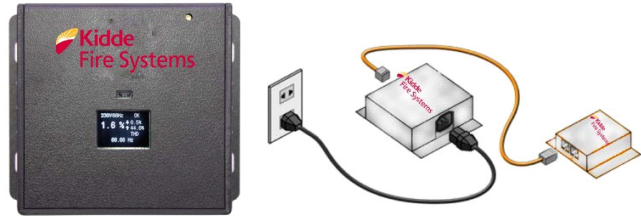

Key Features:

- Plugs into the base unit (31-BASE-WIRED)
- Can be used as a stand-alone device (without the 31-BASE-WIRED)
- Integration via SNMP, ModBus, JSON and XML (Requires 31-BASE-WIRED)
- Alerting via SNMP Traps
- Plug and play, no electrician needed. Simply plug it into an electrical socket and start monitoring your power quality.
- Log file can be downloaded via micro USB 2.0 connection
- With proximity sensor for OLED activation
- THD measurement limits based on IEEE 519-2014

Technical Specifications:

Power Source	SensorGateway (31-BASE-WIRED) 100- 240 VAC
Power Usage	460 mW
Voltage	100-240V AC Single Phase
Voltage sampling rate	0.2s (as per IEC 62053-22)
Frequency	50 - 60hz
Accuracy	+/- 1V
Detects	- short and long power failures or interruptions - voltage swells, spikes or over-voltage - voltage sags, dips or under-voltage - harmonic - voltage distortions (THD) - frequency fluctuations
Operating temperature range	0°C to +75°C (32°F to +167°F)
Operating humidity range	< 90% rH (non-condensating)
Dimensions	124 mm (4.88") x 101 mm (3.97") x 54mm (2.1")
Weight	0.5 kgs (1.1lbs.)

Ultrasonic Fuel Level Probe IP68 Housing (31-PWR-FUEL)

This industrial grade Ultrasonic Fuel Level Probe is a stand-alone solution to monitor the fuel levels in your tanks.

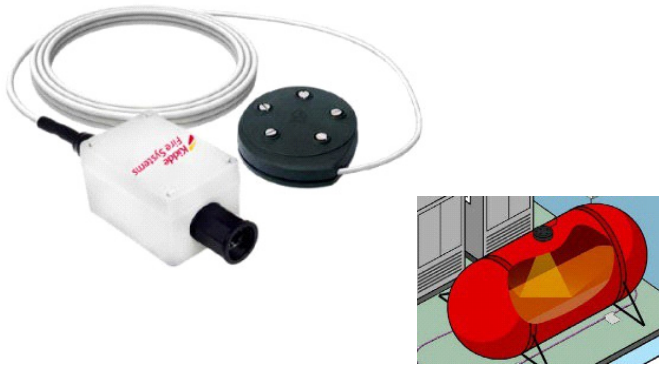

Key Features:

- Plugs into the base unit (31-BASE-WIRED)
- Powered by the base unit (31-BASE-WIRED)
- Compact "Plug-and-Play" sensor
- Contactless (ultrasonic) fuel level measurement
- ISO 8846 ignition protected
- Measures fuel level inside tanks with depths of up to 2m (6.5ft)
- With wall thickness of up to 6mm
- IP68 rates for outdoor use
- Calibrated in factory based on specs of your tank
- Fire Resistance tested to ABYC, US Coast guard and ISO 10088

Technical Specifications:

Power Source	SensorGateway (31-BASE-WIRED) 100- 240 VAC
Power Usage	1008 mW
Mounting	SAE 5 stud mounting pattern with gasket, seal and screws (top mount only)
Measurement method	Acoustic sonic measurement
Tank depth	0-2000 mm (6.5 ft)
Accuracy Distance	0-2000 mm (6.5 ft) at 2 mm accuracy
Chemical resistance	Petrol, diesel
Tank type style	Metal and plastic with non linear capacity
Sensor Housing Material	IP 65 plastic housing
RJ45 cable Gland protection rating	IP 68
Operating temperature range	4°C to 65°C (39F to 148F)
Humidity (operating and storage)	< 90% rH (non-condensating).
Dimensions	65 mm (2.5") x 95 mm (3.74") x 55 mm (2.16")
Weight	2kg (4.4 lbs.)

Door Contact Security Sensor (31-SEC-DOOR)

The Door Contact Security Sensor is designed to be mounted inside racks, cabinets or server room doors. It triggers an alert when the rack door is opened. The sensor directly plugs into the SensorGateway or the SensorHub. The door contact sensor is a magnetic sensor with a self-adhesive or screw mount.

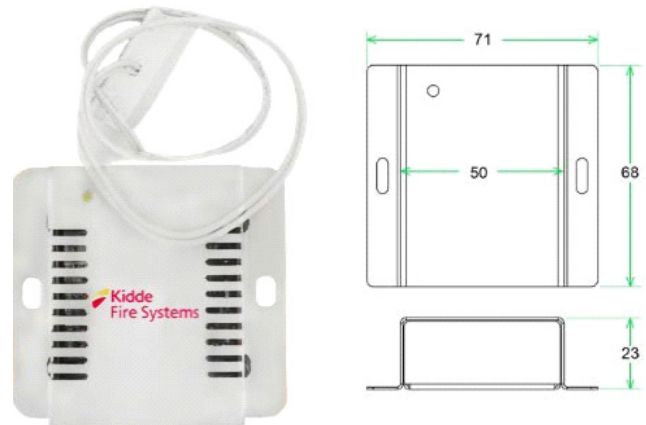

Key Features:

- Plugs into the base unit (31-BASE-WIRED)
- Powered by the base unit (31-BASE-WIRED)
- Compact "Plug-and-Play" sensor
- 0U rack or wall mountable
- Steel enclosure, industrial grade
- Alerts via SNMP Traps
- Returns OPEN or CLOSE state
- Magnetic door contact sensor with self-adhesive or screw mount

Technical Specifications:

Power source	SensorGateway (31-BASE-WIRED)
Power usage	204 mW
Cable Length	0.15" (0.4m) cable from door contact to probe
Operating temperature range	0°C to +75°C (32°F to +167°F)
Humidity (operating and storage)	< 90% rH (non-condensating).
Dimensions	71 mm (2.8") x 68 mm (2.7") x 23 mm (0.9")
Weight	0.13kg (0.28 lbs.)

Light (Lux) Sensor (31-SEC-LUX)

This industrial grade Light (Lux) Sensor is a digital luminosity sensor which measures ambient light in lux (lx).

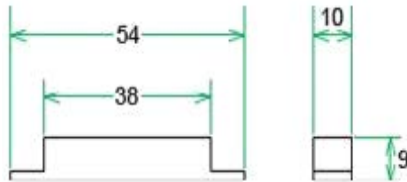

Key Features:

- Plugs into the base unit (31-BASE-WIRED)
- Powered by the base unit (31-BASE-WIRED)
- 0U and rack mountable
- "Plug-and-Play" sensor
- Digital light level sensor
- Reports luminosity in lux
- Monitors from 0 to 65000 lux
- With a 1 lux resolution

Technical Specifications:

Power source	SensorGateway (31-BASE-WIRED)
Power usage	60 mW
Unit	LUX (lx)
Range	0 to 65000 lx
Resolution	1 lux
Operating temperature range	0°C to +75°C (32°F to +167°F)
Humidity (operating and storage)	< 90% rH (non-condensating).
Probe Dimensions	71 mm (2.8") x 68 mm (2.7") x 23 mm (0.9")
Weight	0.13kg (0.28 lbs.)

Motion Sensor (31-SEC-MOTION)

This industrial grade Motion Sensor incorporates digital signal analysis for consistent detection throughout the coverage pattern.



Key Features:

- Plugs into the base unit (31-BASE-WIRED)
- Powered by the base unit (31-BASE-WIRED)
- 0U and rack mountable
- "Plug-and-Play" sensor
- Digital signal analysis
- Digital temperature compensation for improved catch performance at critical temperature levels
- Accurate detection of human IR energy over a broad range of temperatures

Technical Specifications:

Power source	SensorGateway (31-BASE-WIRED)
Power usage	456 mW
Certification	ULC , C-tick, INCERT, CCC, CE, UL
Operating temperature range	0°C to +75°C (32°F to +167°F)
Humidity (operating and storage)	< 90% rH (non-condensating).
Probe Dimensions	71 mm (2.8") x 68 mm (2.7") x 23 mm (0.9")
Weight	0.43kg (0.9 lbs.)

Vibration & Shock Sensor Probe (31-SEC-SHOCK)

Different manufacturers offer vibration sensors that are analog-based: an alert will be triggered if motion has been detected. Unlike those sensors, ServersCheck's Vibration and Shock Sensor will report the actual force being recorded. This multi-axis G force ensures accurate detection of the level of vibration and also allows you to define the exact threshold you want to be alerted on.



Key Features:

- Plugs into the base unit (31-BASE-WIRED)
- Powered by the base unit (31-BASE-WIRED)
- Detect and record tampering, moving, removal or installation of equipment inside racks
- Detect and record vibration or shock inside rooms especially for sensitive equipment such as traditional hard disks

Technical Specifications:

Power source	SensorGateway (31-BASE-WIRED)
Power usage	72 mW
Vibration unit:	G force +/- 2G
Sensor sensitivity:	0.18G
Operating temperature range	0°C to +75°C (32°F to +167°F)
Humidity (operating and storage)	< 90% rH (non-condensating).
Dimensions	74 mm (2.9") x 66 mm (2.59") x 22 mm (0.8")
Weight	0.13kg (0.29 lbs.)

Smoke Sensor UL (31-SEC-SMOKE)

The Smoke Sensor is a photoelectric smoke sensor for monitoring smoke inside facilities.

IMPORTANT NOTE: This smoke sensor does not replace building fire detection systems where such systems are required. It does complement such systems.



Key Features:

- Plugs into the base unit (31-BASE-WIRED)
- Powered by the base unit (31-BASE-WIRED)
- Photoelectric smoke detection
- UL Rated
- 0U and rack mountable
- Self-diagnostics meet NFPA 72 sensitivity testing requirements without the need for external meters
- Comes with built-in dust compensation.
- Built-in sounder
- Patented CleanMe® feature
- Superior protection against false/nuisance alarms caused by dust, RF and ambient light (built-in drift compensation)
- Replaceable optical chamber makes any required cleaning easy

Technical Specifications

Power source	SensorGateway (31-BASE-WIRED)
Power usage	204 mW
Smoke Detection	Photoelectric
Operating temperature range	0°C to +30°C
Humidity (operating and storage)	< 90% rH (non-condensating).
Dimensions	71 mm (2.8") x 68 mm (2.7") x 23 mm (0.9")
Weight	0.43kg (0.9 lbs.)

Security Sound dB Sensor Probe (31-SEC-SOUND)

This Sound Sensor is designed for monitoring noise level in applications for security, safety and health.



Key Features:

- Plugs into the base unit (31-BASE-WIRED)
- Powered by the base unit (31-BASE-WIRED)
- Compact "Plug-and-Play" sensor
- 0U rack or wall mountable
- Steel enclosure, industrial grade
- Alerts via SNMP Traps or voice calls
- Monitor noise levels as per OSHA requirements or for HCAHPS
- Designed for indoor use

Technical Specifications:

Power source	SensorGateway (31-BASE-WIRED)
Power usage	312 mW
Sensor Accuracy	±1db
Sound (db) Resolution:	1 db precision
Sensor range	from 10db to 90db
Humidity (operating and storage)	< 90% rH (non-condensating).
Dimensions	74 mm (2.9") x 66 mm (2.59") x 22 mm (0.8")
Weight	0.12kg (0.26 lbs.)
Operating temperature range	0°C to +75°C (32°F to +167°F)

3-Axis Tilting Sensor (31-SEC-TILT)

This Tilting Sound Sensor is designed for monitoring noise level in applications for security, safety and health.

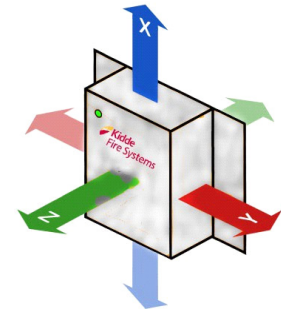

Key Features:

- Plugs into the base unit (31-BASE-WIRED)
- Powered by the base unit (31-BASE-WIRED)
- Compact "Plug-and-Play" sensor
- 0U rack or wall mountable
- Steel enclosure, industrial grade
- Alerts via SNMP Traps
- Monitor noise levels as per OSHA requirements or for HCAHPS
- Designed for indoor use

Technical Specifications:

Power source	SensorGateway (31-BASE-WIRED)
Power usage	312 mW
Sensor Accuracy	±1db
Sound (db) Resolution:	1 db precision
Sensor range	from 10db to 90db
Humidity (operating and storage)	< 90% rH (non-condensating).
Dimensions	74 mm (2.9") x 66 mm (2.59") x 22 mm (0.8")
Weight	0.12kg (0.26 lbs.)
Operating temperature range	0°C to +75°C (32°F to +167°F)

R290 Gas Sensor - Stand-Alone RS-485 output (31-RS485-GAS-R290)

This self-calibrating standalone sensor is designed for monitoring 24x7 refrigerant (R290) levels and detecting leaks from lead acid and lithium-ion battery banks.



Key Features:

- User settable address (RS485) out of 256 possibilities
- Factory calibrated
- Self-calibrating, no field calibration required.

Technical Specifications:

R290	Factory calibrated
Detection range	5-100% LEL
Accuracy	(5-25 %LEL) ± 2.5 %LEL (>25 %LEL) ± 10 %
Response time (T90)	<30 seconds
Warm up time	2 minutes
Calibration frequency	No calibration required
Life span	Up to 15 years
Detection technology	Spectrometer
Relay outputs	2 (Normally Open)
Relay switching current	up to 0.5A
Input Voltage	12-24V DC
Power usage	312mW - 672mW
Protocol	Modbus RTU over RS485 Integration with Base Unit over RJ45 (serial data)
Operating temperature range	-40°C to 75°C (-40°F to 167°F)
Operating humidity range	0-100% rH (non-condensating)
Sensor enclosure	Steel enclosure, industrial grade
Mounting option	0U rack, DIN rail or wall mountable
Dimensions	68.8mm (2.71") x 54mm (2.13") x 34mm (1.34")
Weight	193g (0.43lb)

Battery Cell Module (31-PWR-BAT-CELL) and Battery String Module with CT Transducer (300A) (31-PWR-BAT-STRING)

Industrial grade battery monitoring systems designed for monitoring lead acid, lithium-ion or nickel battery blocks and strings.



Key Features:

- Plugs into the base unit (31-BASE-WIRED)
- Powered by the base unit for up to 15 batteries
- Fused power and measurement circuit for protection
- Battery, rack, wall or DIN rail mountable (31-PWR-BAT-CELL)
- 0U rack, DIN rail or wall mountable (31-PWR-BAT-STRING)
- Wired or optionally wireless
- CE and RoHs compliant
- Can block ripple interference from UPS
- Isolation: 1500 VDC
- Female terminal lug connector
- Monitors the Total Voltage and Total Current
- Monitors Minimum and Maximum Voltage, Temperature, Impedance, and State of Charge for each battery block
- RS485 output (optional)

Technical Specifications:

Power source	SensorGateway (31-BASE-WIRED) for up to 15 batteries
Power usage	500 mW per device
Optional version	31-PWR-BAT-STRING-485 (with RS485 support)
31-PWR-BAT-STRING: Total string current	Accuracy $\pm 0.5\%$ Measurement Range 0-300A Resolution 0.07A
31-PWR-BAT-CELL: Terminal voltage	Measurement Range 1-65V Accuracy $\pm 0.5\%$ Resolution 2%
Battery temperature	Measurement Range -55~+125°C / -67~+257 °F Accuracy $\pm 0.5^\circ\text{C}$ / 0.9°F Resolution 0.1°C / $.18^\circ\text{F}$
Operating temp. range	0°C to +75°C (32°F to +167°F)
Operating humidity range	< 90% rH (non-condensating)
Dimensions	31-PWR-BAT-STRING (150mm x 88mm) 31-PWR-BAT-CELL (80mm x 60mm)

Linear Heat Sensor WITHOUT cable (31-ENV-LHD)

Requires up to 2 circuits of Kidde Fire Systems LHS™ LINEAR HEAT SENSOR CABLE

This Linear Heat Digital Sensor uses Kidde Fire Systems LHS™ Linear Heat Cable to sense heat anywhere along the cable and will initiate an alarm once its fixed activation temperature is reached. Refer to the latest price list found on the Distributor Extranet at kiddefiresystems.com for all available LHS cables (sold separately, not included with purchase of 31-ENV-LHD).

IMPORTANT NOTE: Unlike linear heat cable, the Linear Heat Sensor is not a fire safety device. It is a temperature limit detection device.



Technical Specifications:

Data output	Provides a NORMAL/ALARM detected in Base Unit
Detects the location	in meter
Powered by and communicates with	Base Unit (31-BASE-XX) (required)
Connectivity	RJ45 cable transmitting data and power from Base Unit to Sensor
Cable specification	RJ45 CAT 6/7 recommended Up to 100m (330ft) subject to cable quality & interference
Supported cable	LHS™ Linear Heat Cable cable up to 1200m
Number of supported cables	2
Sensor power usage	468Mw
Operating temperature range	-40°C to +85°C (-40°F+185°F)
Humidity (operating and storage)	< 90% rH (non-condensating)
Sensor enclosure	Steel enclosure, industrial grade
Mounting option	0U rack, DIN rail or wall mountable sensor
Dimensions	74mm (2.9") x 67.5 mm (2.7") x 24 mm (0.9")
Weight	120g (0.26lbs)

Noise & Sound dBA Sensor Probe (31-ENV-NOISE)

The Noise and Sound Sensor Probe monitors indoor sound and noise levels.

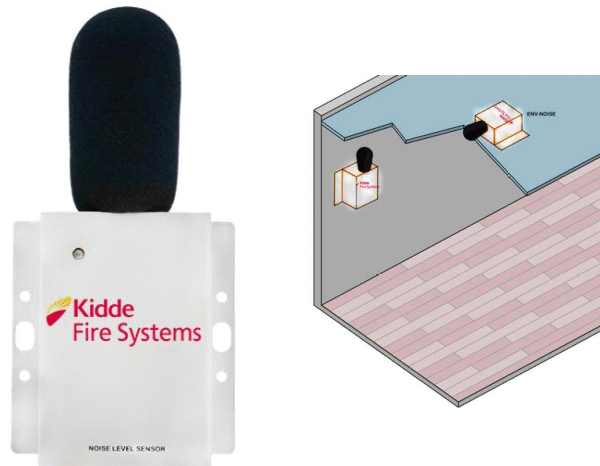

Key Features:

- Plugs into the base unit (31-BASE-WIRED)
- Compact "Plug-and-Play" sensor
- 0U rack or wall mountable
- Steel enclosure, industrial grade
- Alerts via SNMP Traps
- Monitor noise levels as per OSHA requirements or for HCAHPS
- Designed for indoor use

Technical Specifications:

Power Source	SensorGateway (31-BASE-WIRED)
Power Usage	312 mW
Sensor Accuracy	±0.5 dB
Sound (db) Resolution	0.1 db precision
Sensor range	30 - 120dB
Frequency weighting	A weighting
Frequency Response Range	20Hz - 12.5kHz
Operating temperature range	0°C to +50°C (32°F to +167°F)
Relative Humidity (operating and storage)	< 80% rH
Dimensions	72 mm (2.8") x 136 mm (5.4") x 38.5 mm (1.5") / Mic 35mm (1.4") x 65mm(2.56")
Weight	0.12kg (0.26 lbs.)

Ordering Information: (UL Listed components shown highlighted) in yellow)

Description	Part Number
Base Units and Add-Ons	
Base Unit SensorGateway	31-BASE-WIRED (UL Listed UL 62368)
Base Unit IND – 6 SensorGateway	31-BASE-IND-6
Base Unit SensorGateway	31-BASE-PI-5-24V
SensorHub - 8 Ports Hub	31-EXP-8HUB (UL Listed UL 62368)
Sensorhub - 12 Ports Hub	31-EXP-12HUB
24v / -48v DC to PoE Converter (Industrial & Telecom)	31-ADDON-POE
Modbus RTU Slave Add-On	31-ADDON-RTU
Wi-Fi Add-On for Base Unit	31-ADDON-WIFI
Power Adapter for Base Unit	31-BASE-PWR
USB Power Cable for SensorGateway	31-BASE-PWR-USB
Firmware add-on required for GAS, THIMG and OFFGAS sensors	31-BASE-FW-SSLS
Relay Output Module 8 Ports	31-ADDON-8RELAY
Firmware add-on required for all SensorGateway (31-BASE-WIRED)	31-BASE-FW-KFS
Relay Output Module 8 Ports	31-ADDON-8RELAY
Sensors	
VOC, Humidity and Temperature Off-Gas	31-OEM-STD-OFFGAS-LITE (UL Listed UL 61010)
Flammable Gas Sensor	31-R-GAS-FLAMMABLE (UL Listed UL 2075)
Panel Sensor	31-R-EDG-PANEL
Temperature Sensor Calibration	31-CAL-TEMP
Temperature & Humidity Sensor Calibration	31-CAL-THUM
Daisy Chain Voltage Booster	31-DAISY-BOOSTER
Starter for Daisy Chain Sensors	31-DAISY-STARTER (UL Listed UR 61010)
Daisy Chained - Temperature	31-DAISY-TEMP
Daisy Chained - Temp & Humidity	31-DAISY-THUM
Daisy Chained - Infrared Spot Temperature - FOV 5degr	31-DAISY-THIMG-IRSPOT-05
Daisy Chained - Infrared Spot Temperature - FOV 12degr	31-DAISY-THIMG-IRSPOT-12
Daisy Chained - Infrared Spot Temperature - FOV 35degr	31-DAISY-THIMG-IRSPOT-35
Daisy Chained - VOC, Humidity and Temperature Off-Gas	31-DAISY-GAS-VOC (UL Listed UR 61010)
Digital Airflow Sensor Probe	31-ENV-AIRFLOW
Differential Air Pressure Sensor with Built-in temperature sensor	31-ENV-AIRPRESSURE
5m extension cable for battery leak sensor	31-ENV-BLEAK-5M
ACM corrosion Sensor	31-ENV-CORROSION
Indoor Dust Particle Sensor Probe	31-ENV-DUST
Air Quality Sensor VOC and NOx	31-ENV-AIRQUALITY (UL Listed UR 61010)
5m extension cable for fuel leak sensor	31-ENV-FLEAK-5M
A1 Refrigerant Gas Sensor (R134A)	31-GAS-A1 (UL Listed UR 61010)
A2L Refrigerant Gas Sensor (R-32 - R-1234yf)	31-GAS-A2L (UL Listed UR 61010)
A3 Refrigerant Gas Sensor (R-290 - R-404a R-410a)	31-GAS-A3 (UL Listed UR 61010)
Carbon Dioxide (CO2) Gas (NDIR)	31-GAS-CO2-NDIR
Ozone (O3) Gas	31-GAS-O3
SF6 Gas Leak	31-GAS-SF6
Infrared Spot Temperature - FOV 5degr	31-ENV-IRSPOT-05
Infrared Spot Temperature - FOV 12degr	31-ENV-IRSPOT-12
Infrared Spot Temperature - FOV 35degr	31-ENV-IRSPOT-35
Leak Sensor WITHOUT cables	31-ENV-LEAK
Indoor Dust Particle Sensor Probe	31-ENV-DUST (UL Listed UR 61010)
Water Leak Location Sensor WITHOUT cables	31-ENV-LEAK-LOC
Optical Oil Leak Sensor	31-ENV-LEAK-OPTICAL-H
Noise & Sound dBA Sensor Probe	31-ENV-NOISE
Air Particle Sensor (PM1 - 2.5 - 4 and PM10)	31-ENV-PARTICLE
Temperature Sensor	31-ENV-TEMP

Description	Part Number
Sensors (continued)	
Linear Heat Sensor WITHOUT cables. Up to 2 circuits of LHS™ LINEAR HEAT SENSOR CABLE (sold separately)	31-ENV-LHD
Thermal Image Sensor Small - 32*24 - Cilindrical	31-THIMG-CS
Thermal Image Sensor Large - 160*120	31-ENV-THIMG-L (UL Listed UL 62368)
Thermal Image Sensor Medium - 80*60	31-ENV-THIMG-M (UL Listed UL 62368)
Thermal Image Sensor Small - 32*24	31-ENV-THIMG-S (UL Listed UL 62368)
Thermal Image Sensor Extra-Small - 16*12	31-ENV-THIMG-XS (UL Listed UL 62368)
Thermal Image Sensor Small Cylindrical- 32*24	31-ENV-THIMG-CS
Temperature and Humidity Sensor	31-ENV-THUM (UL Listed UR 61010)
Stainless Steel Temperature Sensor (-55C +125C)	31-ENV-TSTAIN
Surface Temperature Sensor	31-ENV-TSURFACE
Ultra Low Temperature Sensor (-200C to +550C)	31-ENV-TULTRA
Leak Sensor WITHOUT cables	31-ENV-LEAK
65ft/ 20m water detection cable	31-ENV-WLEAK-20M
16ft / 5m water detection cable	31-ENV-WLEAK-5M
Leak Sensor with 16ft/5m water detection cable	31-ENV-WLEAK-COMBO5M
Leak Location Sensor with 16ft/5m water detection cable	31-ENV-WLEAK-LOC-COMBO5
Water Spot	31-ENV-WSPOT
IO Sensor Probe - Dry Contact - 16 IN & 4 OUT	31-IND-IO
0-10V adapter for 3rd party industrial sensors & systems	31-IND-0-10V
4-20mA adapter for 3rd party industrial sensors & systems	31-IND-4-20MA
AC Current Sensor Probe max 100A (110-240v)	31-PWR-AC-CUR
AC Power Failure Sensor Probe (110v-240v)	31-PWR-AC-FAIL
AC Power Quality Sensor (110v-240v)	31-PWR-AC-QUAL
Battery Cell Module	31-PWR-BAT-CELL
Battery String Module with CT Transducer (300A)	31-PWR-BAT-STRING
DC Power Voltage Sensor 0-56v DC	31-PWR-DC-VOLT
Ultrasonic Fuel Level Probe IP68 Housing	31-PWR-FUEL
Grounding Sensor	31-PWR-GROUND
Door Contact Security Sensor	31-SEC-DOOR
Light (Lux) Sensor	31-SEC-LUX
Motion Sensor	31-SEC-MOTION
Vibration & Shock Sensor Probe	31-SEC-SHOCK
Smoke Sensor UL	31-SEC-SMOKE
Security Sound dB Sensor Probe	31-SEC-SOUND
3-Axis Tilting Sensor	31-SEC-TILT
R290 Gas Sensor - Stand-Alone RS-485 output	31-RS485-GAS-R290

Supported Sensors For Each SensorGateway:

The table below shows which sensors are supported by the available REL-iON SensorGateways. Please check this table before ordering your sensor(s). A blank box indicates “Not Supported”. **NOTE: This table assumes installation of the latest firmware version on your SensorGateway.**

Kidde Fire Systems Sensor Part Number	31- BASE-PI-5-24V SensorGateway	31-BASE-WIRED SensorGateway	31-BASE-IND-6 SensorGateway
31-ENV-TEMP	Supported	Supported	Supported
31-ENV-THUM	Supported	Supported	Supported
31-ENV-AIRPRESSURE	Supported	Supported	Supported
31-ENV-LEAK	Supported	Supported	Supported
31-ENV-WSPOT	Supported	Supported	Supported
31-ENV-WLEAK-LOC	Supported	Supported	
31-ENV-NOISE	Supported	Supported	Supported
31-ENV-NOISE v2	Supported	Supported	Supported
31-ENV-AIRFLOW	Supported	Supported	Supported
31-ENV-DUST	Supported	Supported	Supported
31-ENV-AIRQUALITY	Supported	Supported	Supported
31-ENV-VOC-NOX	Supported	Supported	Supported
31-ENV-LEAK-OPTICAL	Supported	Supported	
31-ENV-PARTICLE	Supported	Supported	Supported
31-ENV-CORROSION	Supported	Supported	
31-ENV-LHD	Supported	Supported	
31-ENV-CO2	Supported	Supported	
31-ENV-AIRPRESSURE	Supported	Supported	Supported
31-ENV-FLEAK-COMBO	Supported	Supported	Supported
31-ENV-TMAGNET	Supported	Supported	Supported
31-ENV-TSTAIN	Supported	Supported	Supported
31-ENV-TSURFACE	Supported	Supported	Supported
31-ENV-TULTRA	Supported	Supported	Supported
31-PWR-BAT-CELL	Supported	Supported	
31-PWR-BAT-STRING	Supported	Supported	
31-PWR-AC-FAIL	Supported	Supported	Supported
31-PWR-FUEL	Supported	Supported	
31-PWR-DC-VOLT	Supported	Supported	Supported
31-PWR-GROUND v2	Supported	Supported	Supported
31-PWR-AC-CUR	Supported	Supported	Supported
31-PWR-AC-QUAL	Supported	Supported	Supported
31-SEC-LUX	Supported	Supported	Supported

Kidde Fire Systems Sensor Part Number	31- BASE-PI-5-24V SensorGateway	31-BASE-WIRED SensorGateway	31-BASE-IND-6 SensorGateway
31-SEC-SMOKE, 31-SEC-DOOR, 31-SEC-MOTION	Supported	Supported	Supported
31-SEC-SOUND	Supported	Supported	Supported
31-SEC-SHOCK	Supported	Supported	Supported
31-SEC-TILT	Supported	Supported	
31-THIMG-M	Supported	Supported	
31-THIMG-L	Supported	Supported	
31-THIMG-S	Supported	Supported	
31-THIMG-XS	Supported	Supported	
31-THIMG-IRSPOT	Supported	Supported	
31-R-EGD-PANEL	Supported	Supported	
31-R-GAS-FLAMMABLE	Supported	Supported	
31-IND-4TO20	Supported	Supported	
31-IND-0TO10	Supported	Supported	
31-IND-IO	Supported	Supported	Supported
31-ADDON-WIFI	Supported	Supported	Supported
31-ADDON-8RELAY	Supported	Supported	
31-ADDON-RTU	Supported	Supported	Supported
31-ADDON-POE	Supported	Supported	Supported
31-EXP-12HUB	Supported	Supported	
31-EXP-8HUB	Supported	Supported	Supported
31-EXP-4HUB	Supported	Supported	
31-GAS-VOC	Supported	Supported	
31-GAS-VOC-H2	Supported	Supported	
31-GAS-O3	Supported	Supported	
31-GAS-SF6	Supported	Supported	
31-GAS-A1	Supported	Supported	
31-GAS-A2L	Supported	Supported	
31-GAS-A3	Supported	Supported	
31-GAS-CO2-NDIR	Supported	Supported	
31-DAISY-STARTER	Supported	Supported	
31-DAISY-TEMP	Supported	Supported	
31-DAISY-TEMP-MAGNET	Supported	Supported	
31-DAISY-THIMG-IRSPOT-XX	Supported	Supported	
31-DAISY-GAS-VOC	Supported	Supported	
31-DAISY-THUM	Supported	Supported	

Supported Sensors For Each Hub:

The table below shows which sensors are supported by the REL-iON 8-Port and 12-Port Expansion Hubs. Please check this table before ordering your sensor(s). A blank box indicates “Not Supported”. **NOTE: This table assumes installation of the latest firmware version on your SensorGateway**

Kidde Fire Systems Sensor Part Number	31-EXP-8HUB 8-Port Expansion Hub	31-EXP-12HUB 12-Port Expansion Hub
31-ENV-TEMP	Supported	Supported
31-ENV-THUM	Supported	Supported
31-ENV-AIRPRESSURE	Supported	Supported
31-ENV-LEAK	Supported	Supported
31-ENV-WSPOT	Supported	Supported
31-ENV-WLEAK-LOC	Supported	Supported
31-ENV-NOISE	Supported	Supported
31-ENV-NOISE v2	Supported	Supported
31-ENV-AIRFLOW	Supported	Supported
31-ENV-DUST	Supported	Supported
31-ENV-AIRQUALITY	Supported	Supported
31-ENV-VOC-NOX	Supported	Supported
31-ENV-LEAK-OPTICAL	Supported	Supported
31-ENV-PARTICLE	Supported	Supported
31-ENV-CORROSION	Supported	Supported
31-ENV-LHD	Supported	Supported
31-ENV-CO2	Supported	Supported
31-ENV-AIRPRESSURE	Supported	Supported
31-ENV-FLEAK-COMBO	Supported	Supported
31-ENV-TMAGNET	Supported	Supported
31-ENV-TSTAIN	Supported	Supported
31-ENV-TSURFACE	Supported	Supported
31-ENV-TULTRA	Supported	Supported
31-PWR-BAT-CELL		
31-PWR-BAT-STRING		
31-PWR-AC-FAIL	Supported	Supported
31-PWR-FUEL	Supported	Supported
31-PWR-DC-VOLT	Supported	Supported
31-PWR-GROUND v2	Supported	Supported
31-PWR-AC-CUR	Supported	Supported
31-PWR-AC-QUAL	Supported	Supported
31-SEC-LUX	Supported	Supported
31-SEC-SMOKE, 31-SEC-DOOR, 31-SEC-MOTION	Supported	Supported
31-SEC-SOUND	Supported	Supported
31-SEC-SHOCK	Supported	Supported

Kidde Fire Systems Sensor Part Number	31-EXP-8HUB 8-Port Expansion Hub	31-EXP-12HUB 12-Port Expansion Hub
31-SEC-TILT	Supported	Supported
31-THIMG-M	Supported	Supported
31-THIMG-L	Supported	Supported
31-THIMG-S	Supported	Supported
31-THIMG-XS	Supported	Supported
31-THIMG-IRSPOT	Supported	Supported
31-R-EGD-PANEL	Supported	Supported
31-R-GAS-FLAMMABLE	Supported	Supported
31-IND-4TO20	Supported	Supported
31-IND-0TO10	Supported	Supported
31-IND-IO		
31-ADDON-WIFI		
31-ADDON-8RELAY		
31-ADDON-RTU	Supported	Supported
31-ADDON-POE		
31-GAS-VOC	Supported	Supported
31-GAS-VOC-H2	Supported	Supported
31-GAS-O3	Supported	Supported
31-GAS-SF6	Supported	Supported
31-GAS-A1	Supported	Supported
31-GAS-A2L	Supported	Supported
31-GAS-A3	Supported	Supported
31-GAS-CO2-NDIR	Supported	Supported
31-DAISY-STARTER		
31-DAISY-TEMP		Supported
31-DAISY-TEMP-MAGNET		Supported
31-DAISY-THIMG-IRSPOT-XX		Supported
31-DAISY-GAS-VOC		Supported
31-DAISY-THUM		Supported

EXPORT INFORMATION (USA)

Jurisdiction: EAR

Classification: EAR99

This document contains technical data subject to the EAR.

This literature is provided for informational purposes only. Kidde-Fenwal, LLC believes this data to be accurate, but it is published and presented without any guarantee or warranty whatsoever. Kidde-Fenwal, LLC assumes no responsibility for the product's suitability for a particular application. The fire suppression system design, installation, maintenance, service and troubleshooting must be performed by trained, authorized Kidde Fire Systems distributors for the product to work correctly. If you need more information on this product, or if you have a particular problem or question, contact: Kidde-Fenwal, LLC, Ashland, MA 01721 USA.

kiddefiresystems.com
508.881.2000

Kidde Fire Systems, Kidde Fire Protection and Fenwal Controls branded products are created exclusively by Kidde-Fenwal, LLC. All trademarks are the property of their respective owners. All products are the property of their respective owners.



400 Main Street, Ashland, MA 01721
P/N: **K-31-001** Rev. AD | kiddefenwal.com | 508-881-2000
2025 © Kidde-Fenwal, LLC | All Rights Reserved