

## Series LFII Residential Sprinkler Design Guide

### IMPORTANT

Refer to *Technical Data Sheet TFP2300* for warnings pertaining to regulatory and health information.

Scan the QR code or enter the URL in a web browser to access the most up-to-date electronic version of this document. Data rates may apply.



[docs.jci.com/tycofire/TFP490](http://docs.jci.com/tycofire/TFP490)



## Table of Contents

### Sections

General Description . . . . .	1
Design: Background . . . . .	1
Design: Hydraulics . . . . .	2
Design: Sprinkler Location . . . . .	3-4
Installation . . . . .	4
Care and Maintenance . . . . .	4
Limited Warranty . . . . .	4

### Tables

Series LFII Residential Sprinklers . . .	2
Rise Over Run Conversion to Degrees of Slope . . . . .	3

### Figures

Spacing Under Sloped Ceilings . . .	5-8
Positioning of Sprinklers with Respect to Obstructions . . . . .	9

## General Description

Johnson Controls Residential Sprinklers are a type of fast-response automatic sprinklers. They are to be used only in wet or dry pipe residential sprinkler systems for one- and two-family dwellings and mobile homes per NFPA 13D; wet or dry pipe residential sprinkler systems for residential occupancies up to and including four stories in height per NFPA 13R; or, wet or dry pipe sprinkler systems for the residential portions of any occupancy per NFPA 13.

This document provides design guidance for the Series LFII Residential Sprinklers outlined in Table A.

Residential fire sprinkler systems should only be designed and installed by those competent and completely familiar with automatic sprinkler system design, installation procedures, and techniques. Several criteria may apply

to a given installation and usage of each sprinkler. Consequently, the sprinkler system designer is recommended to review and develop a working understanding of the complete list of criteria prior to initiating the design of a residential fire sprinkler system.

### NOTICE

*The Series LFII Residential Sprinklers described herein must be installed and maintained in compliance with this document, as well as with the applicable standards of the NATIONAL FIRE PROTECTION ASSOCIATION, in addition to the standards of any other authorities having jurisdiction. Failure to do so may impair the performance of these devices.*

*The owner is responsible for maintaining their fire protection system and devices in proper operating condition. The installing contractor or sprinkler manufacturer should be contacted with any questions.*

Sprinkler Identification Number (SIN)	Type	K-factor	Technical Data Sheet Number	System Type	NFPA Standard		
TY1234	Pendent and Recessed Pendent	3.0	TFP402	Wet	13D, 13R, 13		
TY2236		4.9	TFP403	Wet, Dry			
TY3934		5.8	TFP401				
TY4234	Pendent, Recessed Pendent and Domed Plate Concealed Pendent	6.9	TFP408				
TY1334	Horizontal Sidewall and Recessed Horizontal Sidewall	4.2	TFP410			Wet	
TY2334		4.4	TFP412				
TY3334		5.6	TFP415				
TY4334		5.8	TFP417				
TY2324	Flat Plate Concealed Horizontal Sidewall	4.2	TFP445	Wet			13D, 13R
TY1534	Flat Plate Concealed Pendent	3.0	TFP439				13D, 13R, 13
TY2534		4.9	TFP446		13D, 13R		
TY3534		4.9	TFP447		13D, 13R		
TY3584		5.8	TFP448	13D, 13R, 13			
TY2235	Dry Recessed Pendent	4.9	TFP460				
TY2335	Dry Horizontal Sidewall and Recessed Horizontal Sidewall	4.4	TFP461	Wet, Dry			

**TABLE A**  
**SERIES LFII RESIDENTIAL SPRINKLERS**

## Design: Background

All Series LFII Residential Sprinklers are tested and listed under UL 1626 “Standard for Residential Sprinklers for Fire Protection Service” with specific published spacings, flows, and pressures for each residential sprinkler identified by its Sprinkler Identification Number (SIN) and as detailed in the Technical Data Sheets referenced in Table A.

The design criteria for Series LFII residential sprinklers contained in the current NFPA Standards must be followed except as modified by the individual UL 1626 listing information provided in the Technical Data Sheets referenced in Table A and this design guide.

**NOTICE**

*The approval of all residential sprinkler designs and installations must be made by the authority having jurisdiction for compliance with all governmental codes and standards.*

## Design: Hydraulics

**NFPA 13D.** The number of design sprinklers shall include all sprinklers within a compartment up to a maximum of two sprinklers where specific UL Listed flows are provided. The minimum required sprinkler flow rate for systems designed to NFPA 13D are given in the Technical Data Sheets referenced in Table A, as a function of temperature rating and the maximum allowable coverage areas.

**Note:** For actual coverage areas less than or between those indicated in the Technical Data Sheets referenced in Table A, it is necessary to use the minimum required flow for the next largest coverage area.

Example No. 1: Assuming the use of a pendent sprinkler, the actual coverage area being protected is 14 ft x 16 ft. In this case the minimum flow requirement for a 16 ft x 16 ft coverage area must be used.

Example No. 2: Assuming the use of a pendent sprinkler, the actual coverage area being protected is 17 ft x 17 ft. In this case the minimum flow requirement for a 18 ft x 18 ft coverage area must be used.

**NFPA 13R.** The number of design sprinklers shall include all sprinklers within a compartment up to a maximum of four sprinklers where specific UL Listed flows are provided. The minimum required sprinkler flow rate for systems designed to NFPA 13R are given in the Technical Data Sheets referenced in Table A, as a function of temperature rating and the maximum allowable coverage areas.

**Note:** For actual coverage areas less than or between those indicated in the Technical Data Sheets referenced in Table A, it is necessary to use the minimum required flow for the next largest coverage area.

Example 1: Assuming the use of a pendent sprinkler, the actual coverage area being protected is 14 ft x 16 ft. In this case the minimum flow requirement for a 16 ft x 16 ft coverage area must be used.

Example 2: Assuming the use of a pendent sprinkler, the actual coverage area being protected is 17 ft x 17 ft. In this case the minimum flow requirement for a 18 ft x 18 ft coverage area must be used.

**NFPA 13.** The number of design sprinklers is to be the four most hydraulically demanding sprinklers. The minimum required discharge from each of the four sprinklers is to be the greater of the following:

- The flow rates given in the Technical Data Sheets referenced in Table A for NFPA 13D and 13R as a function of temperature rating and the maximum allowable coverage area.

**Note:** For actual coverage areas less than or between those indicated in the Technical Data Sheets referenced in Table A, it is necessary to use the minimum required flow for the next largest coverage area.

- A minimum discharge of 0.1 gpm/ft<sup>2</sup> over the “design area” comprised of the four most hydraulically demanding sprinklers for the actual coverage areas being protected by the four sprinklers.

**Note:** The greatest dimension of the actual coverage area cannot be any greater than the maximum coverage areas indicated in the Technical Data Sheets referenced in Table A.

Example 1: A corridor being protected is 8 ft wide; consequently, an actual coverage area of 8 ft x 20 ft is being contemplated. Based on using the LFII (TY2236) Residential Pendent Sprinkler, the flow rate provided in TFP403 for a 20 ft x 20 ft coverage area is 20 gpm. However based on minimum discharge of 0.1 gpm/ft<sup>2</sup> the flow rate would be 16 gpm. In this case a minimum flow rate of 20 gpm for this design sprinkler must be utilized.

Example 2: A long narrow room being protected is 12 ft wide; consequently, an actual coverage area of 12 ft x 20 ft is being contemplated. Based on using the LFII (TY2236) Residential Pendent Sprinkler, the flow rate provided in TFP403 for a 20 ft x 20 ft coverage area is 20 gpm. However based on minimum discharge of 0.1 gpm/ft<sup>2</sup> the flow rate would be 24 gpm. In this case a minimum flow rate of 24 gpm for this design sprinkler must be utilized.

**Compartment.** A compartment is a space that is completely enclosed by walls and a ceiling. The compartment enclosure may have openings to an adjoining space, provided the openings have a minimum lintel depth of 8 inches from the ceiling.

Rise, Inches	12						60°	56°	53°	50°	46°	45°
	11						58°	54°	51°	48°	45°	42°
	10						59°	55°	51°	48°	45°	42°
	9						56°	52°	48°	45°	42°	39°
	8					58°	53°	49°	45°	42°	39°	36°
	7				60°	54°	49°	45°	41°	38°	35°	32°
	6				56°	50°	45°	41°	37°	34°	31°	29°
	5			59°	51°	45°	40°	36°	32°	29°	27°	24°
	4			63°	45°	39°	34°	30°	27°	24°	22°	20°
	3		56°	45°	37°	31°	27°	23°	21°	18°	17°	15°
	2		45°	34°	27°	22°	18°	16°	14°	13°	11°	10°
	1	45°	27°	18°	14°	11°	9°	8°	7°	6°	6°	5°
		1	2	3	4	5	6	7	8	9	10	11

**Run, Inches**

**TABLE B**  
**RISE OVER RUN CONVERSION TO DEGREES OF SLOPE**

**Sloped Ceilings.** For systems designed to NFPA 13, 13D, or 13R and where specific UL Listed flows have not been provided for sloped ceilings, consult with the local authority having jurisdiction with regard to the number of “design sprinklers” for sloped ceilings having a slope greater than a 2 in. rise for a 12 in. run.

## Design: Sprinkler Location

When locating the Series LFII Residential Sprinklers, Sprinkler Spacing, Obstruction To Water Distribution, Heat Sensitivity, Preventing Cold Soldering, and Proximity To A Heat Source must all be considered.

Table B provides a conversion of “Rise Over Run” that is a conventional method of defining slope in architectural drawings to “Degrees Of Slope” as used in this guideline.

### Sprinkler Spacing Under Horizontal Ceilings (Up to 9 degrees of slope).

Residential sprinklers are utilized for various maximum spacings in accordance with minimum flows and pressures. Typical coverage areas for pendent sprinklers are 12 ft x 12 ft up to 20 ft x 20 ft, and typical coverage areas for horizontal sidewall sprinklers are 12 ft x 12 ft up to 16 ft x 20 ft. Refer to the Technical Data Sheets referenced in Table A for coverage areas, and refer to the applicable NFPA standard for Spacing Rules Under Horizontal Ceilings. Understanding the intended area of coverage while using this guide is critical.

Always remember that the spacing of sprinklers under horizontal ceilings with slopes greater than 0 degrees (i.e., non-level) is measured along the slope when determining distance off of walls and between sprinklers.

### Sprinkler Spacing Under Sloped Ceilings (10 to a 60 degrees of slope).

Residential sprinklers are utilized for various maximum spacings in accordance with minimum flows and pressures. Typical coverage areas for pendent sprinklers are 12 ft x 12 ft up to 20 ft x 20 ft, and typical coverage areas for horizontal sidewall sprinklers are 12 ft x 12 ft up to 16 ft x 20 ft. Refer to the Technical Data Sheets referenced in Table A for coverage areas, and see Figure 1 for Spacing Rules Under Sloped Ceilings. Understanding the intended area of coverage while using this guide is critical.

Always remember that the spacing of sprinklers under sloped ceilings is measured along the slope when determining distance off of walls and between sprinklers.

### Obstruction to Water Distribution.

Location with respect to obstructions to water distribution are addressed by the applicable NFPA standard. For other obstruction scenarios which are not addressed by NFPA, see the appropriate figures within this data sheet. If a sprinkler water distribution pattern is obstructed, the obstruction is to be considered the maximum distance of coverage for a given sprinkler and additional sprinklers beyond the obstruction will be necessary. Because of the varied nature of residential type construction, there will be some compartment designs that cannot be fully sprinklered

in accordance with the recommendations of NFPA 13, 13D, or 13R. In the event of this condition, consult with the authority having jurisdiction.

Appendix material in NFPA 13D and 13R references the evaluation of certain small areas.

Small areas created by architectural features such as planter box windows, bay windows, and similar features can be evaluated as follows:

(a) Where no additional floor space area is created by the architectural feature, no additional sprinkler protection is required.

(b) Where additional floor space is created by an architectural feature, no additional sprinkler protection is required, provided all of the following conditions are met:

- The floor area does not exceed 18 square feet.
- The floor area is not greater than 2 feet in depth at the deepest point of the architectural feature to the plane of the primary wall where measured along the finished floor.
- The floor is not greater than 9 feet in length where measured along the plane of the primary wall.

Measurement from the deepest point of the architectural feature to the sprinkler should not exceed the maximum listed spacing of the sprinkler. The hydraulic design is not required to consider the area created by the architectural feature.

Figure 2 provides guidance for positioning of pendent and horizontal sidewall sprinklers with respect to obstructions along a wall, and in the case of pendent sprinklers the positioning of sprinklers on both sides of a continuous obstruction located at the ceiling. Consideration must be given to the size of the obstruction, as well as the allowable deflector-to ceiling distance.

**Heat Sensitivity.** Sensitivity to heat is critical for prompt operation of a residential sprinkler for a fire condition. The Technical Data Sheets referenced in Table A provide the allowable sprinkler deflector-to-ceiling distances.

Residential sprinklers are to be installed beneath smooth flat ceilings as defined by NFPA 13.

#### **NOTICE**

*Special consideration, such as increasing the number of design sprinklers being hydraulically calculated, must be given to installations where continuous obstructions to heat flow are present (e.g.: beams, lintels, etc.).*

*Under a sloped ceiling, the residential sprinkler(s) located at the highest elevation must not be located more than 3 feet measured vertically down from the peak.*

**Preventing Cold Solder.** A minimum distance between residential sprinklers to prevent cold soldering, such as the wetting from an operated sprinkler onto an unoperated sprinkler that could prevent its potential to operate if needed, must be maintained.

Under horizontal ceilings, the minimum distance between residential sprinklers to prevent cold soldering is 8 feet.

Sloped ceilings, however, present more of a cause for concern for cold soldering, since the elevation of one sprinkler may be higher than another, resulting in a different distribution pattern than that of a horizontal ceiling condition.

Figure 1 - Spacing Rules Under Sloped Ceilings addresses the minimum acceptable distance under various sloped ceiling conditions that will take into account the prevention of cold soldering.

One solution to prevent cold soldering is to stagger the sprinklers so that the distance between two sprinklers is increased. In some cases, baffles can be located midway between two closely located sprinklers to prevent cold soldering.

**Proximity To A Heat Source.** Sprinklers must be located so as to prevent an inadvertent operation due to exposure of normal heat sources. Location with respect to exposure of heat sources other than fire that may cause an inadvertent operation of a residential sprinkler. Refer to the applicable NFPA standard.

## **Installation**

The Series LFII Residential Sprinklers must be installed in accordance with the applicable Technical Data Sheet referenced in Table A.

## **Care and Maintenance**

The Series LFII Residential Sprinklers must be maintained and serviced in accordance with the applicable Technical Data Sheet referenced in Table A.

Sprinklers which are found to be leaking or exhibiting visible signs of corrosion must be replaced.

The owner is responsible for the inspection, testing, and maintenance of their fire protection system and devices in compliance with this document, as well as with the applicable standards of the NATIONAL FIRE PROTECTION ASSOCIATION, such as NFPA 25, in addition to the standards of any other authorities having jurisdiction. Contact the installing contractor or sprinkler manufacturer regarding any questions.

Automatic sprinkler systems should be inspected, tested, and maintained by a qualified Inspection Service in accordance with local requirements and/or national codes.

## **Limited Warranty**

For warranty terms and conditions, visit [www.tyco-fire.com](http://www.tyco-fire.com).

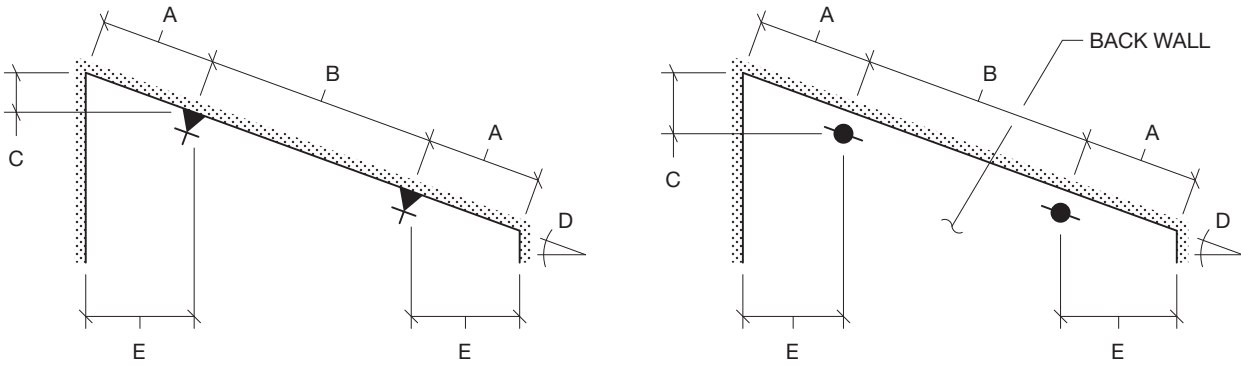

**PENDENT SPRINKLERS**  
ELEVATION

**SIDEWALL SPRINKLERS**  
ELEVATION

- A - MAXIMUM: ONE HALF THE MAXIMUM SPRINKLER SPACING (SEE TECHNICAL DATA SHEETS REFERENCED IN TABLE A) FOR THE COVERAGE AREA BEING HYDRAULICALLY CALCULATED
- B - MAXIMUM: THE MAXIMUM SPRINKLER SPACING (SEE TECHNICAL DATA SHEETS REFERENCED IN TABLE A) FOR THE COVERAGE AREA BEING HYDRAULICALLY CALCULATED  
MINIMUM: 8'-0"
- C - MAXIMUM: 3'-0"
- D - RANGE: 10° - 60° CEILING ANGLE.
- E - MINIMUM: 4"

**FIGURE 1 (PART 1 OF 6)**  
**SPRINKLER SPACING UNDER HORIZONTAL CEILINGS**  
**MULTIPLE SPRINKLERS ON SAME SLOPE AND DISTANCE OFF WALLS**

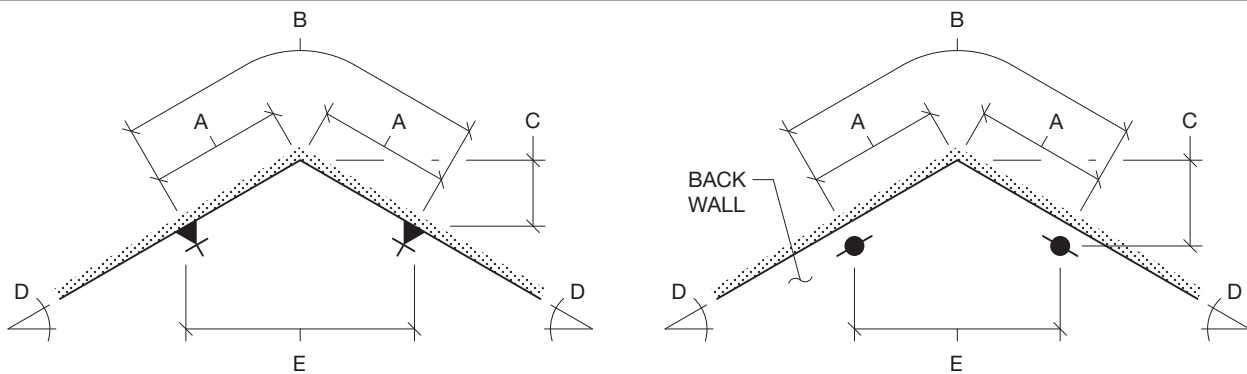

**PENDENT SPRINKLERS**  
ELEVATION

**SIDEWALL SPRINKLERS**  
ELEVATION

- A - MAXIMUM: ONE HALF THE MAXIMUM SPRINKLER SPACING (SEE TECHNICAL DATA SHEETS REFERENCED IN TABLE A) FOR THE COVERAGE AREA BEING HYDRAULICALLY CALCULATED
- B - MAXIMUM: THE MAXIMUM SPRINKLER SPACING (SEE TECHNICAL DATA SHEETS REFERENCED IN TABLE A) FOR THE COVERAGE AREA BEING HYDRAULICALLY CALCULATED  
MINIMUM: 8'-0"
- C - MAXIMUM: 3'-0"
- D - RANGE: 10° - 60° CEILING ANGLE.
- E - MINIMUM: 8'-0"

**FIGURE 1 (PART 2 OF 6)**  
**SPRINKLER SPACING UNDER SLOPED CEILINGS**  
**SYMMETRIC SPRINKLER LOCATIONS ON OPPOSING SLOPES**

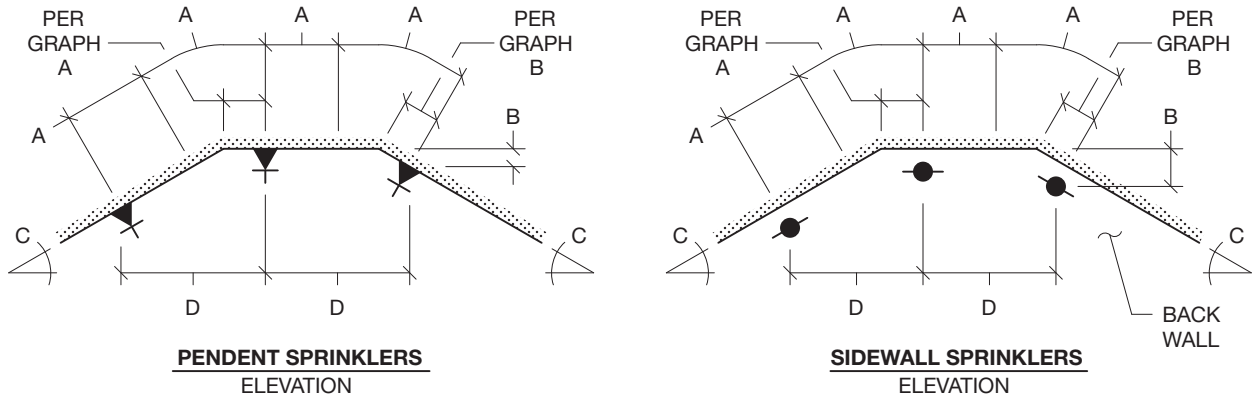

- A - MAXIMUM: ONE HALF THE MAXIMUM SPRINKLER SPACING (SEE TECHNICAL DATA SHEETS REFERENCED IN TABLE A) FOR THE COVERAGE AREA BEING HYDRAULICALLY CALCULATED.
- B - MAXIMUM: 3'-0" WHEN THERE ARE NO SPRINKLERS ON THE LEVEL CEILING
- C - RANGE: 10° - 60° CEILING ANGLE.
- D - MINIMUM: 8'-0"

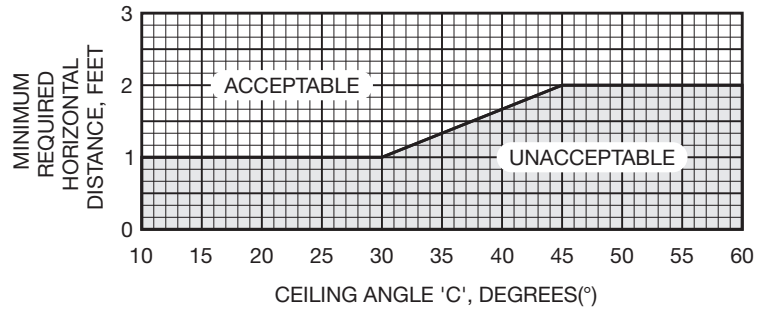

**GRAPH A**

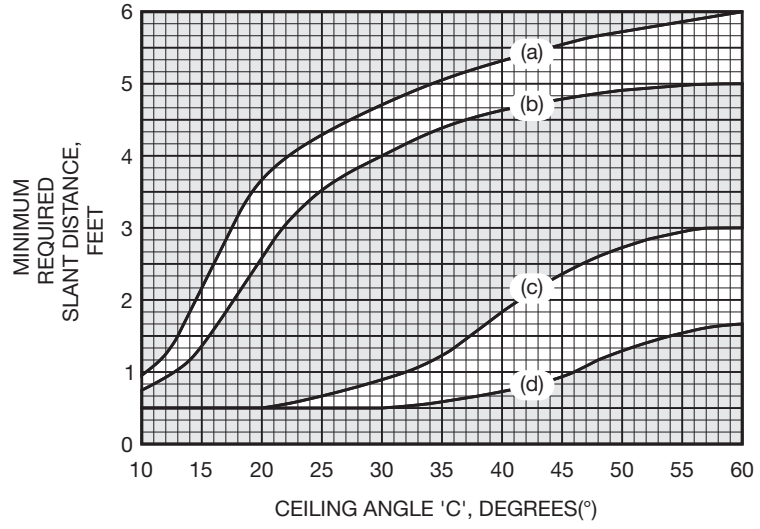

SPRINKLER SPACING (SEE TECHNICAL DATA SHEETS REFERENCED IN TABLE A) BEING HYDRAULICALLY CALCULATED:

- (a) 20'
- (b) 18'
- (c) 16'
- (d) 14'
- (d) 12'

**GRAPH B**

**FIGURE 1 (PART 3 OF 6)**  
**SPRINKLER SPACING UNDER SLOPED CEILINGS**  
**SPRINKLERS LOCATED ON INTERSECTING HORIZONTAL AND SLOPE CEILINGS**

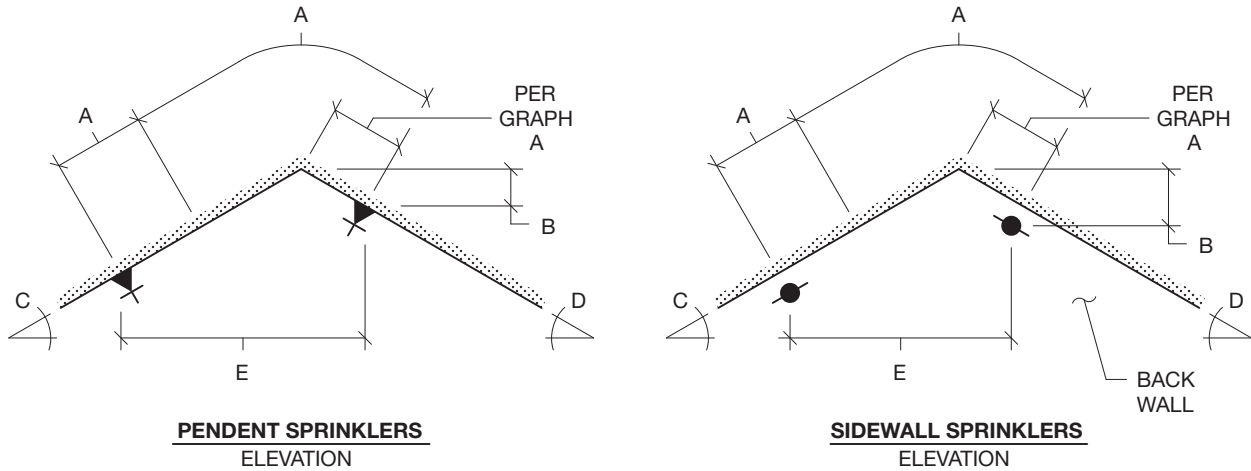

- A - MAXIMUM: ONE HALF THE MAXIMUM SPRINKLER SPACING (SEE TECHNICAL DATA SHEETS REFERENCED IN TABLE A) FOR THE COVERAGE AREA BEING HYDRAULICALLY CALCULATED.
- B - MAXIMUM: 3'-0"
- C - RANGE: 10° - 45° CEILING ANGLE.
- D - RANGE: 10° - 45° CEILING ANGLE.
- E - MINIMUM: 8'-0"

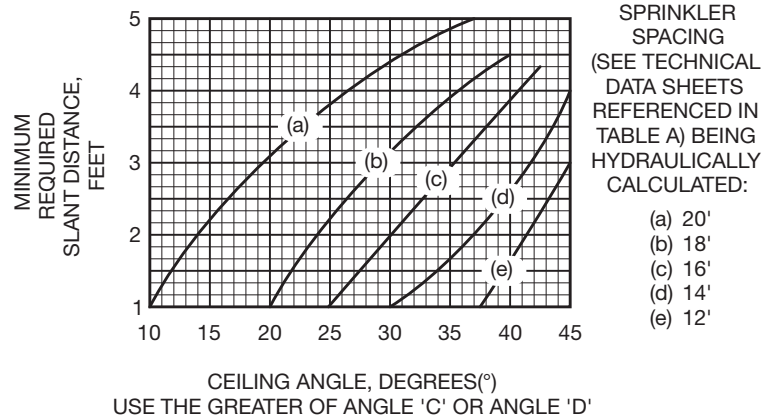

SPRINKLER SPACING (SEE TECHNICAL DATA SHEETS REFERENCED IN TABLE A) BEING HYDRAULICALLY CALCULATED:

- (a) 20'
- (b) 18'
- (c) 16'
- (d) 14'
- (e) 12'

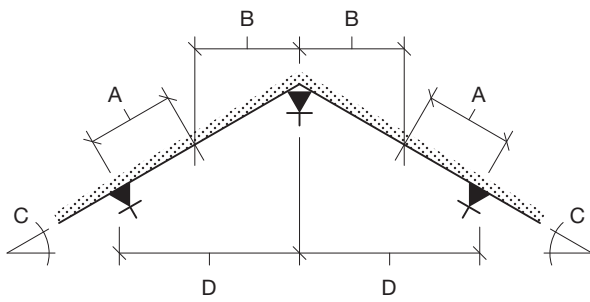

**PENDENT SPRINKLERS**  
**ELEVATION**

- A - MAXIMUM: ONE HALF THE MAXIMUM SPRINKLER SPACING (SEE TECHNICAL DATA SHEETS REFERENCED IN TABLE A) FOR THE COVERAGE AREA BEING HYDRAULICALLY CALCULATED
- B - MAXIMUM: THE MAXIMUM SPRINKLER SPACING (SEE TECHNICAL DATA SHEETS REFERENCED IN TABLE A) FOR THE COVERAGE AREA BEING HYDRAULICALLY CALCULATED OR AS RESTRICTED BY GRAPH A
- C - RANGE: 10° - 60° CEILING ANGLE.
- D - MINIMUM: 8'-0"

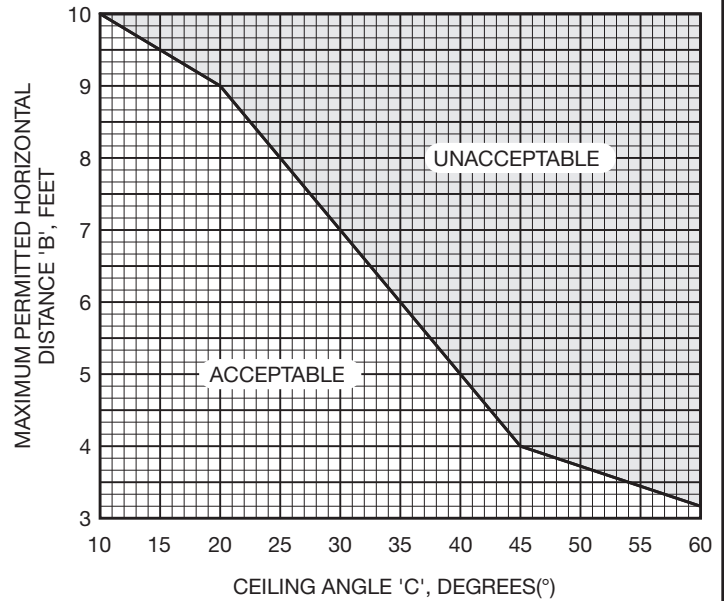

**GRAPH A**

**FIGURE 1 (PART 5 OF 6)**  
**SPRINKLER SPACING UNDER SLOPED CEILINGS**  
**PENDENT SPRINKLERS LOCATED AT PEAK**

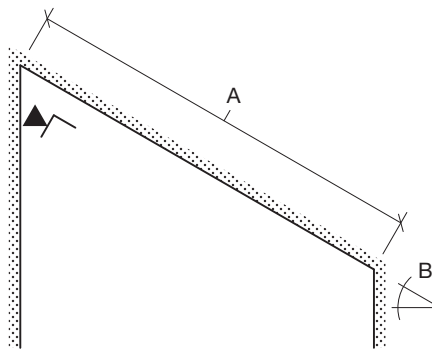

**SIDEWALL SPRINKLERS**  
**ELEVATION**

- A - MAXIMUM: UP TO THE MAXIMUM SPRINKLER COVERAGE AREA LENGTH (SEE TECHNICAL DATA SHEETS REFERENCED IN TABLE A) FOR THE COVERAGE AREA BEING HYDRAULICALLY CALCULATED.
- B - RANGE: 10° - 45° CEILING ANGLE.

**FIGURE 1 (PART 6 OF 6)**  
**SPRINKLER SPACING UNDER SLOPED CEILINGS**  
**SIDEWALL SPRINKLERS LOCATED AT PEAK**

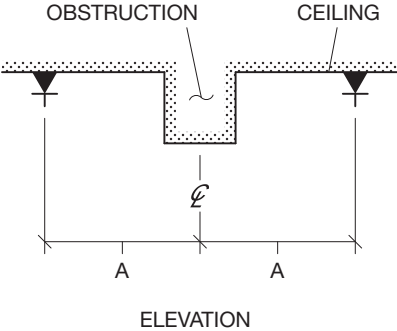

PENDENT SPRINKLERS MAY BE LOCATED ON OPPOSITE SIDES OF AN OBSTRUCTION NOT EXCEEDING 4 FEET IN WIDTH PROVIDING THE DISTANCE FROM THE CENTERLINE OF THE OBSTRUCTION TO THE SPRINKLERS DO NOT EXCEED ONE HALF THE MAXIMUM SPRINKLER SPACING "A" (SEE TECHNICAL DATA SHEETS REFERENCED IN TABLE A)

**FIGURE 2 (PART 1 OF 2)**  
**POSITION OF PENDENT SPRINKLERS ON OPPOSITE SIDES OF CONTINUOUS OBSTRUCTIONS AT THE CEILING**

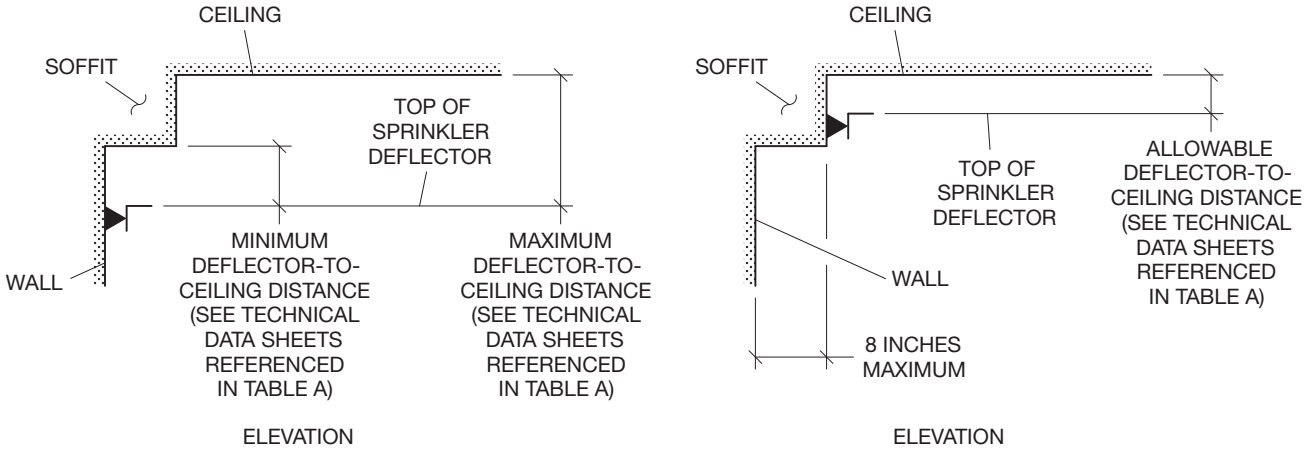

**FIGURE 2 (PART 2 OF 2)**  
**POSITION OF HORIZONTAL SIDEWALL SPRINKLERS WITH RESPECT TO OBSTRUCTIONS ALONG A WALL TO AVOID OBSTRUCTION TO WATER DISTRIBUTION**

