

## Sprinkler Guards, Shields, and Intermediate Level Accessories

### IMPORTANT

Refer to Technical Data Sheet TFP2300 for warnings pertaining to regulatory and health information.

Always refer to Technical Data Sheet TFP700 for the "INSTALLER WARNING" that provides cautions with respect to handling and installation of sprinkler systems and components. Improper handling and installation can permanently damage a sprinkler system or its components and cause the sprinkler to fail to operate in a fire situation or cause it to operate prematurely.

Scan the QR code or enter the URL in a web browser to access the most up-to-date electronic version of this document. Data rates may apply.



[docs.jci.com/tycofire/TFP780](http://docs.jci.com/tycofire/TFP780)

## General Description

TYCO Sprinkler Guards and Shields are designed for use as accessories for sprinklers located in areas that make them susceptible to mechanical or physical damage.

Installation of Guards and Shields on Sprinklers form Intermediate Level Sprinkler assemblies intended for use in fire sprinkler systems designed in accordance with the standard installation rules recognized by the applicable Listing agency, for example the UL Listing is based on NFPA requirements.



Model G1 and G4 Sprinkler Guards, G1/S1 and G4/S3 Sprinkler Guard with Shield assemblies, and S2, S4 and S5 Sprinkler Shields are compatible with specific types of Series TY-B, TY-FRB, TY-L, and TY-FRL sprinklers. See Table A. The Model G1 Sprinkler Guard in a stainless steel finish may also be used with the TYCO Type ULF Stainless Steel AM6 nozzle.

Model G2 Sprinkler Guard, WSG-2 Sprinkler Guard with Shield assembly, and WS-2 Sprinkler Shield are compatible with Series ELO-231, ELO-231B, and ELO-231FRB. See Table A.

The Model G5 Sprinkler Guard is compatible with Series DS-1 dry-type sprinklers. See Table A.

The Model G6 Sprinkler Guard is compatible with Model K11-231B and K11-231FRB sprinklers. See Table A for more details.

In addition to providing protection from mechanical or physical damage, Model G1/S1, G4/S3, G6/S3, and WSG-2 Guard with Shield assemblies protect upright sprinklers from water spray of higher elevation sprinklers, for example, rack storage sprinkler installations.

Pendent sprinklers located in areas not susceptible to the threat of mechanical or physical damage can be equipped with Model S2, S4, S5, and WS-2 Shields for protection from water spray of higher elevation sprinklers.

### NOTICE

*Sprinkler Guards, Shields, and Guard with Shield assemblies described herein must be installed and maintained in compliance with this document and with the applicable standards of the NATIONAL FIRE PROTECTION ASSOCIATION (NFPA), in addition to the standards of any authorities having jurisdiction. Failure to do so may impair the performance of these devices.*

*The Model G5 Sprinkler Guard cannot be installed in recessed applications. The Model G5 Guard can be installed only on Series DS-1 sprinklers with standard and deep escutcheons, as well as sprinklers without escutcheons.*

*The owner is responsible for maintaining their fire protection system and devices in proper operating condition. Contact the installing contractor or product manufacturer with any questions.*

Sprinkler							Compatibility and Approvals		
Model	Data Sheet	SIN	Orientation	K-Factor	Thread Size NPT	Mounting Location	Guard	Guard with Shield	Shield
TY-B	TFP151	TY1151	Upright	2.8	1/2"	Thread Relief	G1 (1, 3)	N/A	N/A
	TFP151	TY1251	Pendent	2.8	1/2"	Thread Relief	G1 (1, 3)	N/A	N/A
	TFP152	TY315	Upright	5.6	1/2"	Thread Relief	G1 (1, 2, 3)	G1/S1 (1,2, 3)	N/A
	TFP152	TY325	Pendent	5.6	1/2"	Thread Relief	G1 (1, 2, 3)	N/A	S2 (1, 2, 3)
	TFP151	TY3151	Upright	5.6	1/2"	Thread Relief	G1 (1, 2, 3), G4 (2)	G1/S1 (1, 2, 3)	N/A
	TFP151	TY3251	Pendent	5.6	1/2"	Thread Relief	G1 (1, 2, 3), G4 (2)	N/A	S2 (1, 2, 3)
	TFP351	TY3153	Upright	5.6	1/2"	Factory Assm	N/A	N/A	(1, 2, 3)
	TFP151	TY4851	Upright	8.0	1/2"	Thread Relief	G1 (1, 2, 3)	N/A	N/A
	TFP151	TY4951	Pendent	8.0	1/2"	Thread Relief	G1 (1, 2, 3)	N/A	N/A
	TFP151	TY4151	Upright	8.0	3/4"	Thread Relief	G1 (1, 2, 3)	G1/S1 (1, 2, 3)	N/A
	TFP151	TY4251	Pendent	8.0	3/4"	Thread Relief	G1 (1, 2, 3)	N/A	S2 (1, 2, 3)
	TFP351	TY4153	Upright	8.0	3/4"	Factory Assm	N/A	N/A	(1, 2, 3)
	TFP161	TY3351	HSW	5.6	1/2"	Thread Relief	G4 (1, 2, 3)	N/A	N/A
	TFP161	TY3451	VSW	5.6	1/2"	Thread Relief	G4 (1, 3)	N/A	N/A
TY-FRB	TFP171	TY1131	Upright	2.8	1/2"	Thread Relief	G1 (1, 3)	N/A	N/A
	TFP171	TY1231	Pendent	2.8	1/2"	Thread Relief	G1 (1, 3)	N/A	N/A
	TFP172	TY313	Upright	5.6	1/2"	Thread Relief	G1 (1, 2, 3)	G1/S1 (1,2, 3)	N/A
	TFP172	TY323	Pendent	5.6	1/2"	Thread Relief	G1 (1, 2, 3)	N/A	S2 (1, 2, 3)
	TFP171	TY3131	Upright	5.6	1/2"	Thread Relief	G1 (1, 2, 3), G4 (2)	G1/S1 (1, 3)	N/A
	TFP171	TY3231	Pendent	5.6	1/2"	Thread Relief	G1 (1, 2, 3), G4 (2)	N/A	S2 (1, 2, 3)
	TFP356	TY3133	Upright	5.6	1/2"	Factory Assm	N/A	N/A	(1, 2, 3)
	TFP171	TY4131	Upright	8.0	3/4"	Thread Relief	G1 (1, 2, 3)	G1/S1 (1, 3)	N/A
	TFP171	TY4231	Pendent	8.0	3/4"	Thread Relief	G1 (1, 2, 3)	N/A	S2 (1, 2, 3)
	TFP356	TY4133	Upright	8.0	3/4"	Factory Assm	N/A	N/A	(1, 2, 3)
	TFP176	TY3331	HSW	5.6	1/2"	Thread Relief	G4 (1, 3)	N/A	N/A
TFP176	TY3431	VSW	5.6	1/2"	Thread Relief	G4 (1, 3)	N/A	N/A	
ELO-231	TFP340	TY5111	Upright	11.2	3/4"	Thread Relief	G2 (1, 2, 3)	WSG-2 (1, 3)	N/A
	TFP340	TY5211	Pendent	11.2	3/4"	Thread Relief	G2 (1, 2, 3)	N/A	WS-2 (1, 3)
	TFP340	TY5811	Upright	11.2	1/2"	Thread Relief	G2 (1, 2, 3)	WSG-2 (1, 3)	N/A
ELO-231B	TFP342	TY5151	Upright	11.2	3/4"	Thread Relief	G2 (1, 2, 3)	WSG-2 (1, 3)	N/A
	TFP342	TY5251	Pendent	11.2	3/4"	Thread Relief	G2 (1, 2, 3)	N/A	WS-2 (1, 3)
	TFP342	TY5851	Upright	11.2	1/2"	Thread Relief	G2 (1, 2, 3)	WSG-2 (1, 3)	N/A

**Notes:**  
1. UL Listed  
2. FM Approved  
3. C-UL Listed  
N/A Not Applicable

**TABLE A (1 OF 2)  
SPRINKLER GUARD AND SHIELD  
LABORATORY LISTINGS AND APPROVALS**

## Technical Data

Model G1 and G4 Sprinkler Guards are redesignations for Gem F938 and F937 respectively.

Model G1/S1 and G4/S3 Sprinkler Guard with Shield assemblies are redesignations for Gem F938/Q-76 and F937/Q-75 respectively.

Model G2 Sprinkler Guard, WSG-2 Sprinkler Guard with Shield, and WS-2 Sprinkler Shield are re-designations for Central G2, WSG-2, and WS-2 respectively.

**Approvals**  
UL and C-UL Listed  
FM Approved  
See Table A

### Finishes\*

Plain Brass, Red Painted, Chrome Plated, Zinc Coated, Zinc Chromate, and Stainless Steel

\* See Ordering Procedure for applicability

### Physical Characteristics

Sprinkler guards, shields, and guard with shield assemblies are carbon steel; o-rings are EPDM

Sprinkler							Compatibility and Approvals		
Model	Data Sheet	SIN	Orientation	K-Factor	Thread Size NPT	Mounting Location	Guard	Guard with Shield	Shield
ELO- 231FRB	TFP344	TY5131	Upright	11.2	3/4"	Thread Relief	G2 (1, 2, 3)	WSG-2 (1, 2, 3)	N/A
	TFP344	TY5231	Pendent	11.2	3/4"	Thread Relief	G2 (1, 2, 3)	N/A	WS-2 (1, 2, 3)
	TFP344	TY5831	Upright	11.2	1/2"	Thread Relief	G2 (1, 3)	WSG-2 (1, 3)	N/A
K11-231B	TFP343	TY5150	Upright	11.2	3/4"	Thread Relief	G6 (1, 2, 3)	G6/S3 (1, 2, 3)	N/A
K11-231FRB	TFP345	TY5130	Upright	11.2	3/4"	Thread Relief	G6 (1, 2, 3)	G6/S3 (1, 2, 3)	N/A
TY-L	TFP110	TY3111	Upright	5.6	1/2"	Wrench Area	G1 (2), G4 (1, 3)	G4/S3 (1, 3)	N/A
	TFP350	TY3113	Upright	5.6	1/2"	Factory Assm	N/A	N/A	(1, 2, 3)
	TFP110	TY3211	Pendent	5.6	1/2"	Wrench Area	G1 (2), G4 (1, 3)	N/A	S5 (1, 2, 3)
	TFP110	TY4811	Upright	8.0	1/2"	Wrench Area	G4 (1, 2, 3)	G4/S3 (1, 3)	N/A
	TFP110	TY4911	Pendent	8.0	1/2"	Wrench Area	G4 (1, 3)	N/A	N/A
	TFP110	TY4111	Upright	8.0	3/4"	Wrench Area	G4 (1, 2)	N/A	N/A
	TFP350	TY4113	Upright	8.0	3/4"	Factory Assm	N/A	N/A	(1, 2, 3)
	TFP110	TY4211	Pendent	8.0	3/4"	Wrench Area	G4 (1, 3)	N/A	(1, 2, 3)
TY-FRL	TFP130	TY1121	Upright	2.8	1/2"	Wrench Area	G4 (1, 3)	N/A	N/A
	TFP130	TY1221	Pendent	2.8	1/2"	Wrench Area	G4 (1, 3)	N/A	N/A
	TFP130	TY3121	Upright	5.6	1/2"	Wrench Area	G4 (1, 2, 3)	G4/S3 (1, 3)	N/A
	TFP355	TY3123	Upright	5.6	1/2"	Factory Assm	N/A	N/A	(1, 2, 3)
	TFP130	TY3221	Pendent	5.6	1/2"	Wrench Area	G4 (1, 3)	N/A	S4 (1, 2, 3)
	TFP140	TY3321	HSW	5.6	1/2"	Wrench Area	G4 (1, 3)	N/A	N/A
	TFP130	TY4121	Upright	8.0	3/4"	Wrench Area	G4 (1, 2, 3)	G4/S3 (1, 3)	N/A
	TFP355	TY4123	Upright	8.0	3/4"	Factory Assm	N/A	N/A	(1, 2, 3)
	TFP130	TY4221	Pendent	8.0	3/4"	Wrench Area	G4 (1, 3)	N/A	S4 (1, 2, 3)
DS-1	TFP500	TY3255	Pendent	5.6	N/A	Wrench Area	G5* (1, 3)	N/A	N/A
	TFP510	TY3235	Pendent	5.6	N/A	Wrench Area	G5* (1, 3)	N/A	N/A
	TFP500	TY3355	HSW	5.6	N/A	Wrench Area	G5* (1, 3)	N/A	N/A
	TFP510	TY3335	HSW	5.6	N/A	Wrench Area	G5* (1, 3)	N/A	N/A
DS-1 Stainless Steel	TFP560	TY3230	Pendent	5.6	N/A	Wrench Area	G5* (1, 3)	N/A	N/A
	TFP560	TY3250	Pendent	5.6	N/A	Wrench Area	G5* (1, 3)	N/A	N/A
	TFP560	TY3337	HSW	5.6	N/A	Wrench Area	G5* (1, 3)	N/A	N/A
	TFP560	TY3357	HSW	5.6	N/A	Wrench Area	G5* (1, 3)	N/A	N/A
AM6 Stainless Steel	TFP2206	AM6	Pendent	0.33	1/2"	Thread Relief	Stainless Steel G1 (4)	N/A	N/A

**Notes:**  
1. UL Listed  
2. FM Approved  
3. C-UL Listed  
N/A Not Applicable

\* Model G5 Guard can be installed only on sprinklers with standard and deep escutcheons, as well as sprinklers without escutcheons. G5 Guard cannot be installed in recessed applications.

**TABLE A (2 OF 2)  
SPRINKLER GUARD AND SHIELD  
LABORATORY LISTINGS AND APPROVALS**

## Design Criteria

In accordance with the requirements of the NFPA, Sprinkler Guards and Shields shall be Listed. Guards and Shields are Listed or Approved for use only with specific sprinklers:

Models G1, G4, G1/S1, G4/S3, S2, S4, and S5 must be used only with Series TY-B, TY-FRB, TY-L, and TY-FRL sprinklers as applicable.

Model G2, WSG-2, and WS-2 must be used only with Series ELO-231, ELO-231B, and ELO-231FRB sprinklers as applicable.

Model G5 must be used only with the Series DS-1 sprinklers.

Both Model G6 Guard and G6/S3 Guard with Shield must be used only with Model K11-231B and K11-231FRB upright sprinklers.

See Table A for specific compatibility and Listings or Approvals.

Type	Model <sup>1</sup>	Orientation <sup>2</sup>	Dimension in. (mm)		Parts					Notes:
			A (Diameter)	B (Height)	1	2	3	4	5	
Guard	G1	a, b	2-7/8 (73,0)	2-5/16 (58,7)	Base Plate	Guard Bar	Guard Clip	N/A	N/A	<ol style="list-style-type: none"> <li>See Table A for sprinkler or nozzle compatibility</li> <li>Orientation restrictions:  a. Upright  b. Pendent  c. Horizontal Sidewall  d. Vertical Sidewall</li> <li>Factory assembled</li> <li>Sprinklers or nozzles not included, shown for application example only</li> <li>Engage guard base plates on sprinkler mounting locations, see Table A for details</li> <li>Engage shields with o-rings in pendent applications between sprinklers and fittings</li> </ol>
	G4	a, b, c, d		3-7/16 (87,3)						
	G6	a		3-3/16 (80,8)						
Guard with Shield	G1/S1	a	4 (101,6)	2-3/8 (60,3)	N/A	N/A	N/A	Shield <sup>3</sup>	N/A	
	G4/S3		4-3/4 (120,7)	3-1/2 (88,9)						
	G6/S3		3-1/4 (82,6)	3-1/4 (82,6)						
Shield	S2	b	3-1/2 (88,9)	N/A	N/A	N/A	N/A	Shield	O-Ring	
	S4		4-1/8 (104,8)						O-Ring	
	S5		3 (76,2)						O-Ring (Qty. 2)	

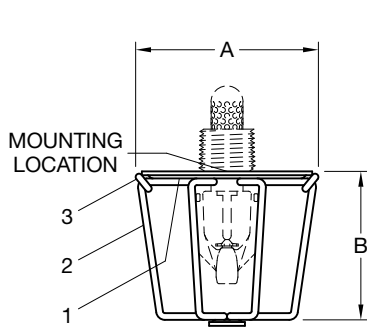

**MODEL G1 GUARD**  
WITH EXAMPLE 1/2" NPT PENDENT  
STAINLESS STEEL TYPE AM6 NOZZLE

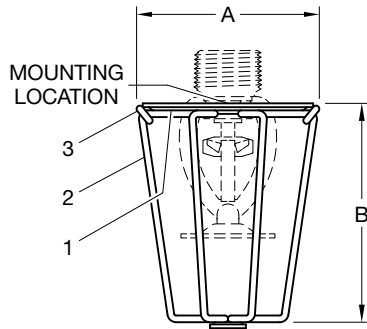

**MODEL G4 GUARD**  
WITH EXAMPLE 3/4" NPT PENDENT  
SERIES TY-FRL SPRINKLER

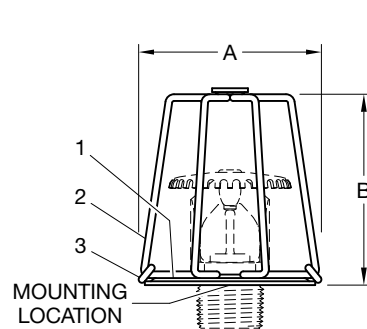

**MODEL G6 GUARD**  
WITH EXAMPLE 3/4" NPT UPRIGHT  
MODEL K11-231FRB SPRINKLER

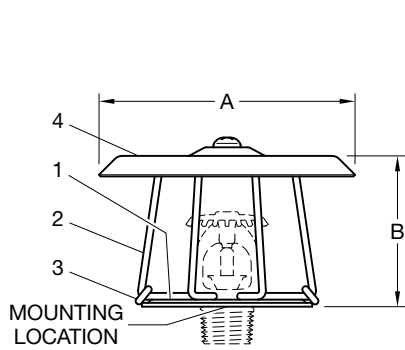

**MODEL G1/S1 GUARD WITH SHIELD**  
WITH EXAMPLE 1/2" NPT UPRIGHT  
SERIES TY-B SPRINKLER

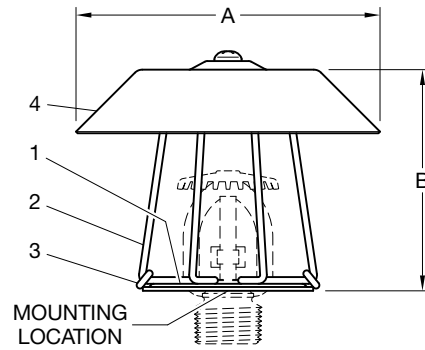

**MODEL G4/S3 GUARD WITH SHIELD**  
WITH EXAMPLE 3/4" NPT UPRIGHT  
SERIES TY-L SPRINKLER

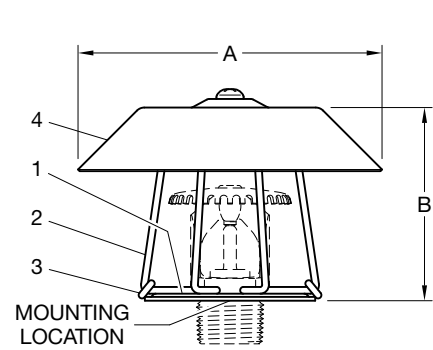

**MODEL G6/S3 GUARD WITH SHIELD**  
WITH EXAMPLE 3/4" NPT UPRIGHT  
MODEL K11-231B SPRINKLER

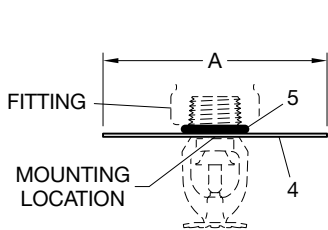

**MODEL S2 SHIELD**  
WITH EXAMPLE 1/2" NPT PENDENT  
SERIES TY-B SPRINKLER

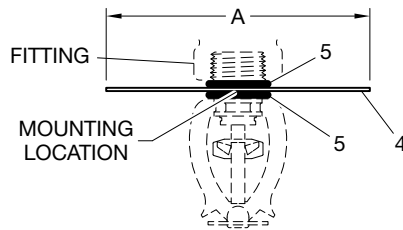

**MODEL S4 SHIELD**  
WITH EXAMPLE 1/2" NPT PENDENT  
SERIES TY-FRL SPRINKLER

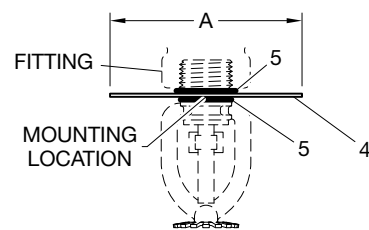

**MODEL S5 SHIELD**  
WITH EXAMPLE 1/2" NPT PENDENT  
SERIES TY-L SPRINKLER

**FIGURE 1**  
**SPRINKLER GUARDS AND SHIELDS COMPATIBLE WITH**  
**SERIES TY-B, TY-FRB, TY-L, TY-FRL, MODEL K11-231B AND K11-231FRB SPRINKLERS**  
**AND AQUAMIST TYPE ULF AM6 NOZZLE**

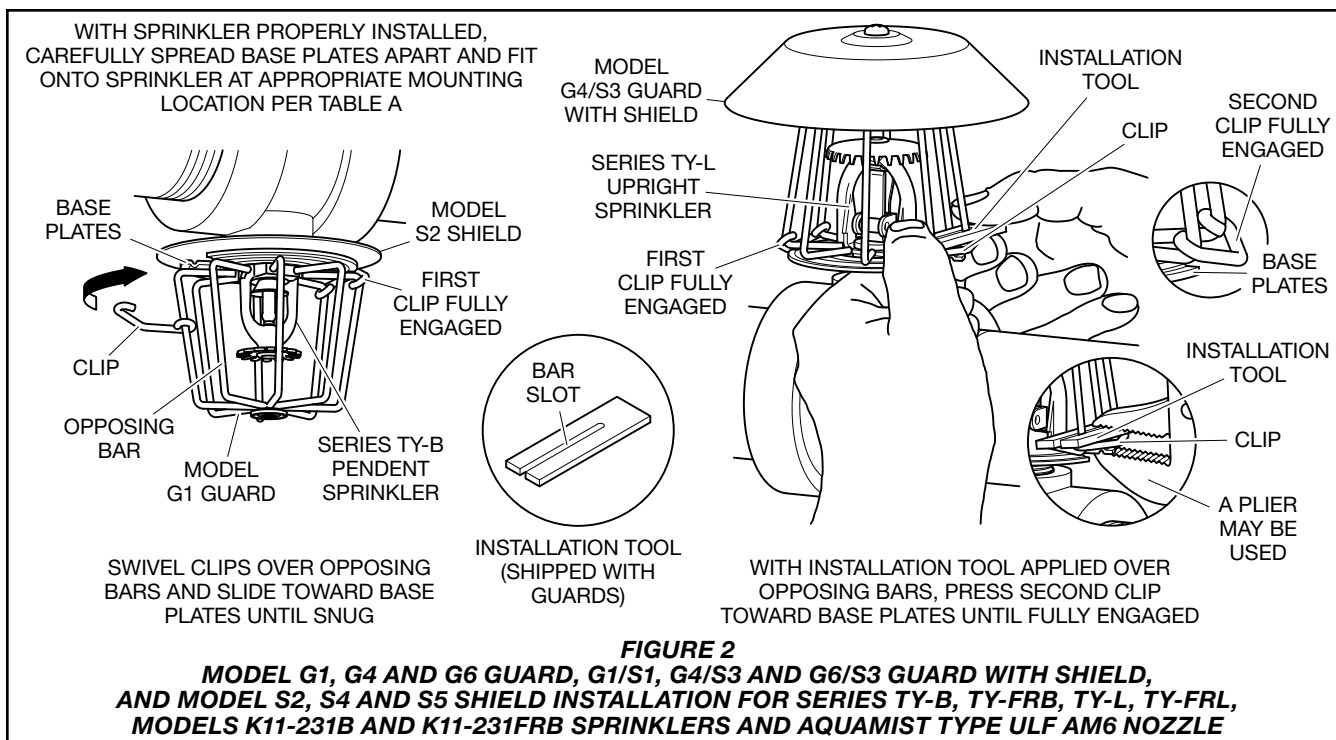

## Installation

### Series TY-B, TY-FRB, TY-L, TY-FRL, Models K11-231B and K11-231FRB Sprinklers and AquaMist Type ULF AM6 Nozzle

TYCO Model G1, G4, and G6 Sprinkler Guards, G1/S1, G4/S3, and G6/S3 Sprinkler Guard with Shield assemblies, and Model S2, S4, and S5 Sprinkler Shields must be installed in accordance with this section. See Figures 1 and 2.

**Note:** AquaMist Type ULF AM6 Nozzle compatible with only Model G1 Guard. See Table A for details.

#### G1, G4, and G6 Guard and G1/S1, G4/S3, and G6/S3 Guard with Shield Installation

**Step 1.** Install the sprinkler or nozzle in accordance with the applicable technical data sheet. See Table A.

**Step 2.** With the Clips unhooked, carefully spread the two halves of the Guard sufficiently to clear the sprinkler or nozzle frame and the deflector or diffuser from the side and mount the Guard on the sprinkler.

**Step 3.** Engage the sprinkler or nozzle mounting location, see Table A, by the Guard Base Plates.

**Step 4.** With the Base Plates positioned on the sprinkler or nozzle mounting feature, slide the Clips away from the Base Plates and swivel them to engage the Bars of the opposing halves of Guard.

**Step 5.** Slide the Clips until seated against the Base Plates.

**Step 6.** Fully engage the Clips against the Base Plates.

**Note:** A Guard Installation Tool may be used to reduce the effort required to fully engage the Clips. Additionally, a common pliers can be used to facilitate engagement of the Clips.

#### NOTICE

Both Clips must be seated and fully engaged against the Base Plates to complete the installation.

Guard Base Plates and Bars may be oriented in any position axially relative to the sprinkler or nozzle frame arms.

Take care when entering upright sprinklers into guards as to avoid overextending the guard halves and potential damage to the sprinkler's deflector.

#### S2, S4 and S5 Shield Installation

##### Notes:

Install a Shield on the pendent sprinklers alone or in conjunction with a G1 or G4 Sprinkler Guard.

Assemble the Shield onto the sprinkler prior to installing the sprinkler into the sprinkler fitting.

**Step A.** Install an O-Ring on the TY-FRL sprinkler or on the TY-L sprinkler, see Figure 1.

**Step B.** With the stamped markings facing toward the deflector, thread the Shield onto the sprinkler threads to the end nearest the frame arms or until flush with the O-Ring as applicable.

**Note:** Final installation step is easier to complete if the Shield is not assembled onto the sprinkler beyond the end of the threads.

**Step C.** Install an O-Ring over the sprinkler threads until flush against the Shield.

**Step D.** Install the sprinkler into the sprinkler fitting in accordance with the applicable sprinkler technical data sheet. See Table A.

**Step E.** Install the Guard (pendent applications as applicable).

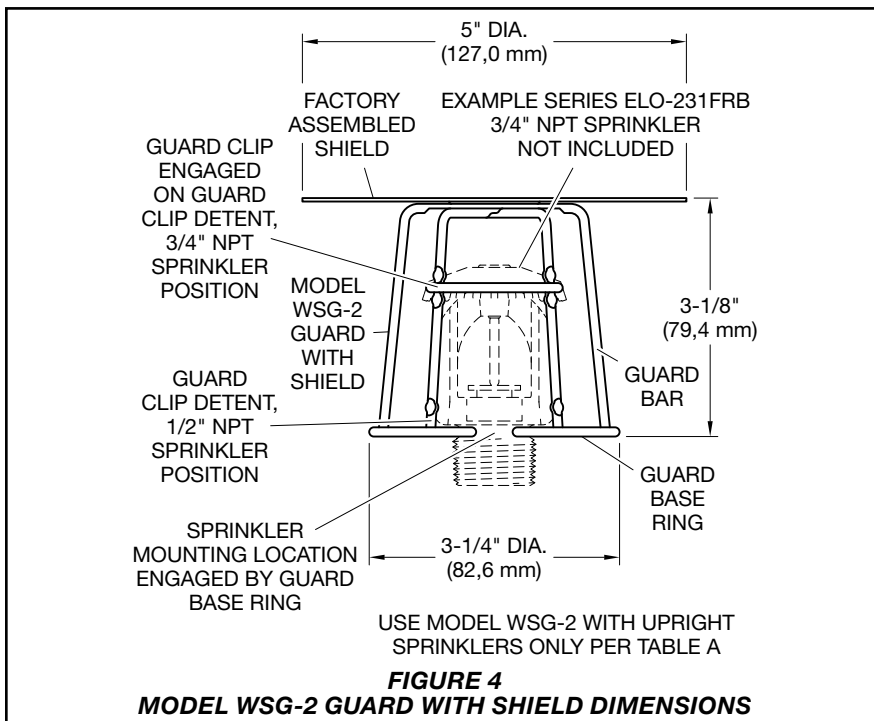
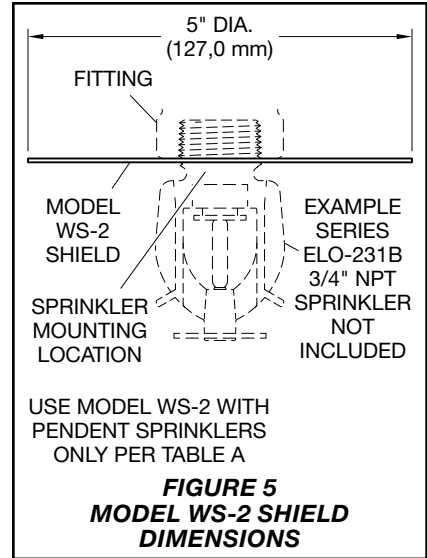
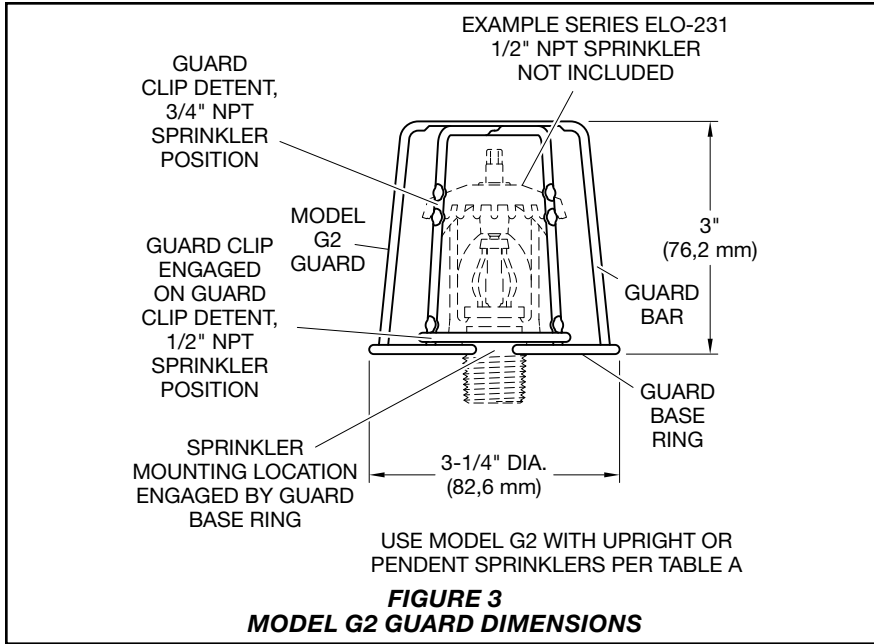

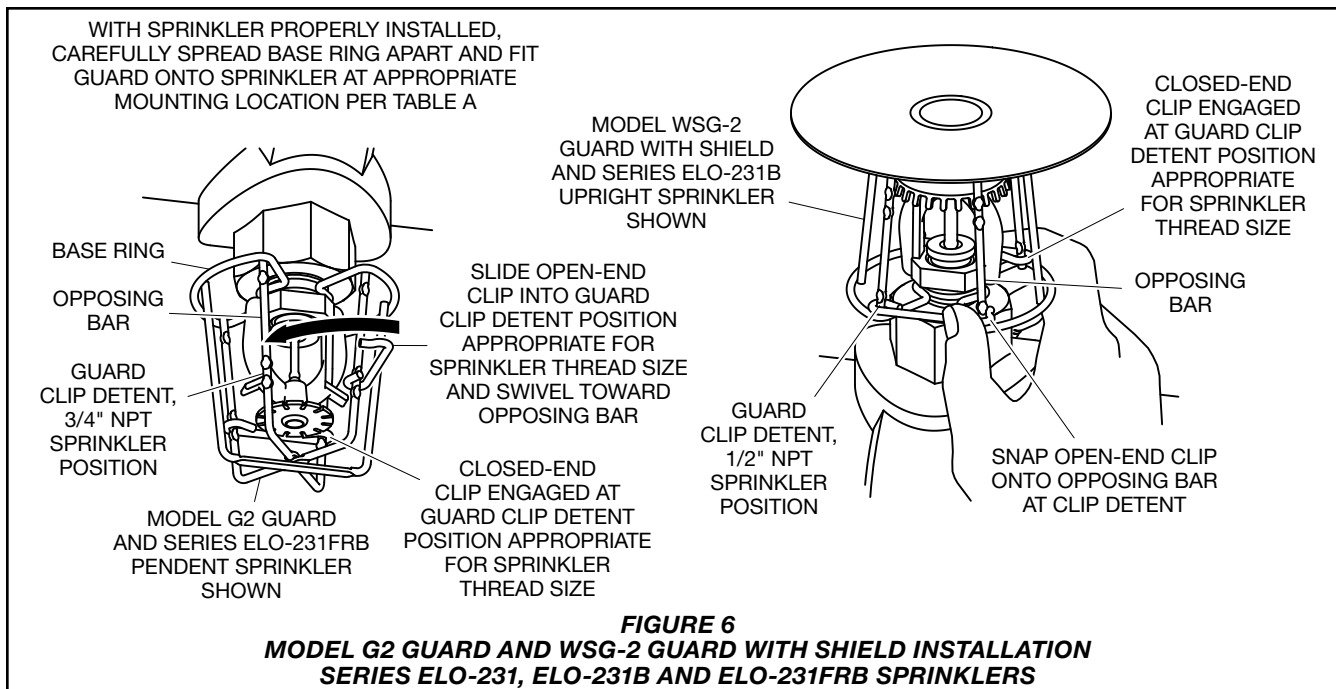

## Installation

### Series ELO-231, ELO-231B, and ELO-231FRB Sprinklers

TYCO Model G2 Sprinkler Guards, WSG-2 Sprinkler Guard with Shield assemblies, and Model WS-2 Sprinkler Shields must be installed in accordance with this section. See Figures 3 to 6.

#### G2 Guard and WSG-2 Guard with Shield Installation

**Step 1.** Install the sprinkler in accordance with the applicable technical data sheet. See Table A.

**Step 2.** With the Clips loose, carefully spread the two halves of the Guard sufficiently to clear the sprinkler frame and deflector from the side, and mount the Guard on the sprinkler.

**Step 3.** Engage the sprinkler mounting location, see Table A, by the inner diameter of the Guard Base Ring.

**Step 4.** With the Base Ring positioned on the sprinkler mounting feature, slide the Clips away from the Guard Base Ring and swivel them to engage the Bars of opposing halves of the Guard.

**Step 5.** Slide the Clips until the Guard Clip Detents applicable to the sprinkler thread size are engaged. Two sets of detents are featured:

- Set farthest from Guard Base Ring accommodates 3/4 in. NPT sprinklers.
- Set closest to Guard Base Ring accommodates 1/2 in. NPT sprinklers.

**Notes:**

Ensure a tight fit between the Clip and the Detents. If loose, carefully bend the Clip slightly and repeat the process until a tight fit is obtained.

Clips must seat securely in appropriate Detents to be considered fully engaged and in order to complete the installation.

Guard Base Ring and Bars may be oriented in any position axially relative to the sprinkler frame arms.

#### WS-2 Shield Installation

**Notes:**

Install a Model WS-2 Shield on the pendent sprinklers alone or in conjunction with a G2 Sprinkler Guard.

Assemble the Shield onto the sprinkler prior to installing the sprinkler into the sprinkler fitting.

**Step A.** With the stamped markings facing toward the deflector, thread the Shield onto the sprinkler threads to the end nearest the frame arms.

**Note:** Final installation step is easier to complete if the Shield is not assembled onto the sprinkler beyond the end of threads.

**Step B.** Install the sprinkler into the sprinkler fitting in accordance with the applicable sprinkler technical data sheet. See Table A.

**Step C.** Rotate the Shield clockwise until flush against the face of the sprinkler fitting.

**Step D.** Install the Guard (pendent applications as applicable).

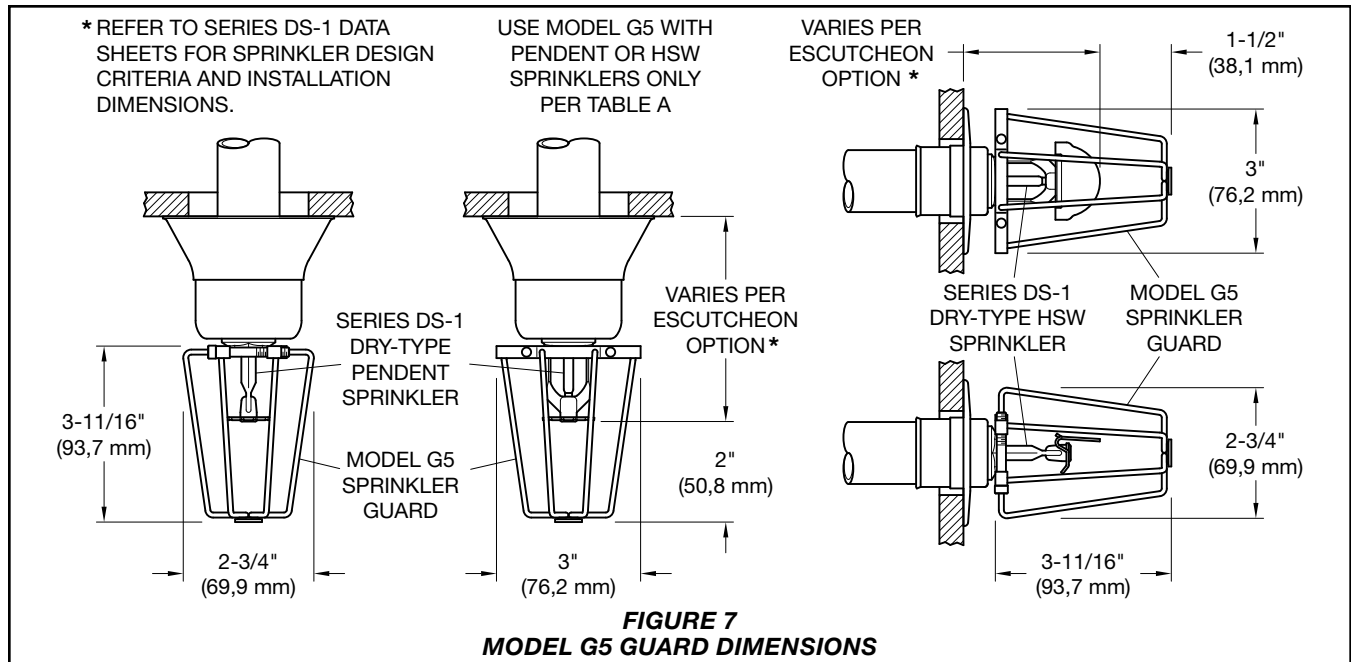

## Installation

### Series DS-1 Sprinklers

TYCO Model G5 Sprinkler Guards must be installed in accordance with this section. See Figures 7 and 8.

### G5 Guard Installation

#### NOTICE

*This procedure requires a 9/64 in. (3,5 mm) Allen Wrench.*

**Step 1.** Install the sprinkler in accordance with the applicable technical data sheet. See Table A.

**Step 2.** Loosen the Guard Screws and carefully separate the halves of the Guard. See Figure 8A.

**Note:** G5 Sprinkler Guard is designed to fit over the sprinkler deflector without removing the Screws. However, if necessary to provide adequate clearance over the deflector, loosen or remove the Screws and separate the Base Plates.

**Step 3.** Remove the sprinkler bulb protector and carefully pass the Guard over the deflector without damaging the sprinkler. Alter alignment as necessary. See Figure 8B.

**Step 4.** Align the centerline of the Guard with the centerline of the sprinkler while guiding the Base Plates toward the sprinkler.

**Step 5.** Position the Grips on the sprinkler wrench flats. Proper position is achieved when the Base Plates are seated against the sprinkler frame base. See Figure 8C.

**Step 6.** While firmly holding the Guard in position against the sprinkler frame base, alternately tighten the Screws with a 9/64 in. (3,5 mm) Allen Wrench until evenly snug and the Grips uniformly engage the sprinkler wrench flats. See Figure 8C.

**Step 7.** Evenly apply a final torque of 5 to 6 ft-lb to both Screws. See Figure 8C.

**Step 8.** Inspect the Guard installation to verify:

- Guard centerline is aligned with the sprinkler centerline
- Base Plates are fully seated against the sprinkler frame base
- Grips are evenly engaged with the sprinkler wrench flats
- Screws are equally engaged across the Base Plates

#### NOTICE

*Base Plates must seat against the sprinkler frame base to be fully engaged and in order to complete the installation.*

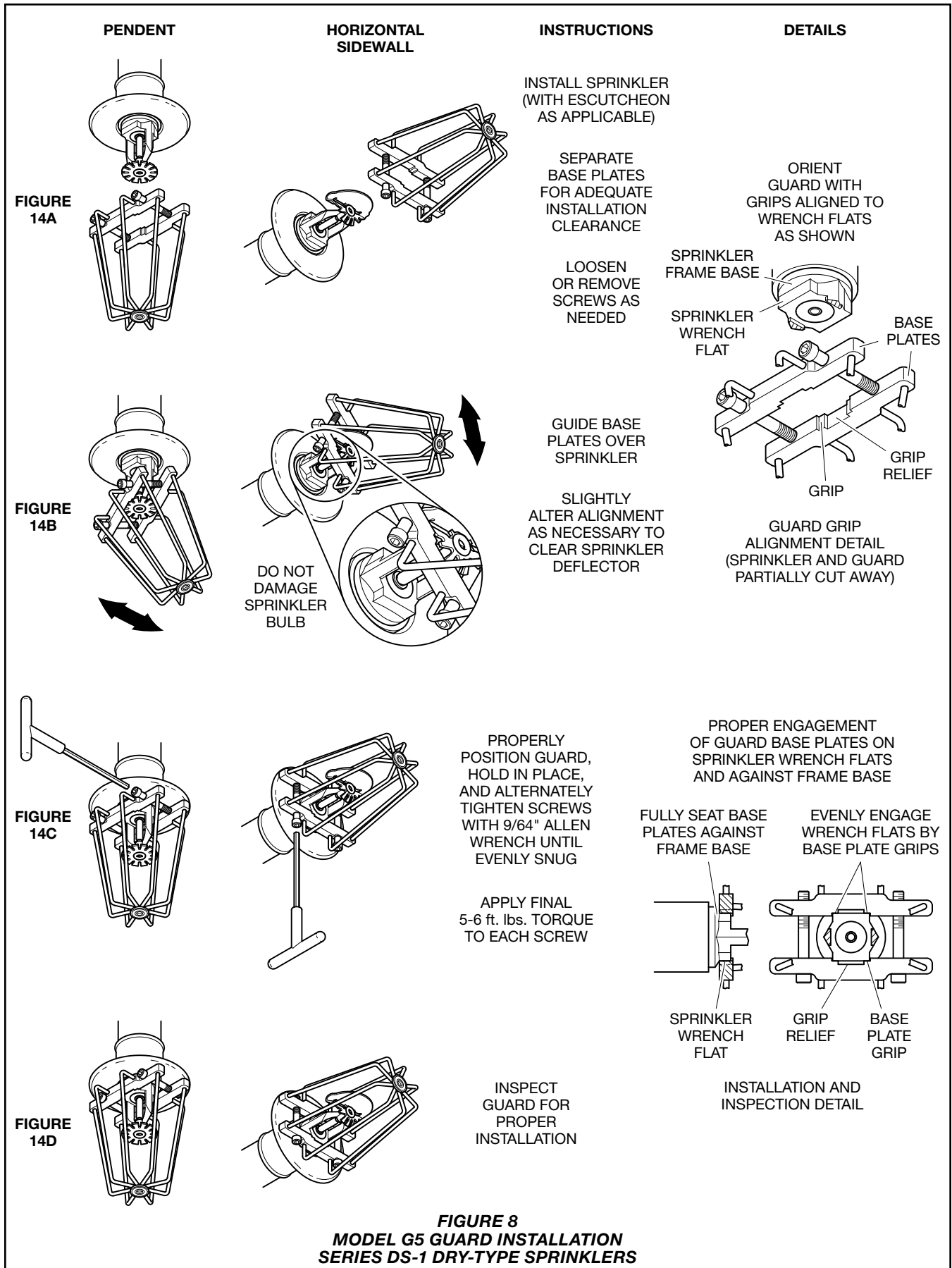

**FIGURE 8**  
**MODEL G5 GUARD INSTALLATION**  
**SERIES DS-1 DRY-TYPE SPRINKLERS**

## Care and Maintenance

TYCO Model G1, G2, G4, G5, and G6 Sprinkler Guards, G1/S1, G4/S3, G6/S3, and WSG-2 Sprinkler Guards with Shields, and S2, S4, S5, and WS-2 Sprinkler Shields do not require any regularly scheduled maintenance; however, proper installation of the Sprinkler Guards and Shields should be verified during the annual visual inspection of the sprinklers.

Before closing a fire protection system main control valve for maintenance work on the fire protection system that it controls, obtain permission to shut down the affected fire protection system from the proper authorities and notify all personnel who may be affected by this action.

The owner is responsible for the inspection, testing, and maintenance of their fire protection system and devices in compliance with this document, as well as with the applicable standards of the NFPA such as NFPA 25, in addition to the standards of any other authorities having jurisdiction. Contact the installing contractor or product manufacturer with any questions.

Automatic sprinkler systems are recommended to be inspected, tested, and maintained by a qualified Inspection Service in accordance with local requirements and/or national codes.

The owner must assure that the sprinklers are not used for hanging of any objects and that the sprinklers are only cleaned by means of gently dusting with a feather-duster. Otherwise, non-operation in the event of a fire or inadvertent operation may result.

## Limited Warranty

For warranty terms and conditions, visit [www.tyco-fire.com](http://www.tyco-fire.com).

## Ordering Procedure

Contact your local distributor for availability. When placing an order, indicate the full product name and Part Number (P/N).

### Model G1 Sprinkler Guard

Specify: Model G1 Sprinkler Guard, (specify) finish, P/N (specify):

Red Painted	569381001
Zinc Chromate	569389001
Stainless Steel	569380001

### Model G2 Sprinkler Guard

Specify: Model G2 Sprinkler Guard, (specify) finish, P/N (specify):

Red Painted	560001087
Zinc Coated	560001086

### Model G4 Sprinkler Guard

Specify: Model G4 Sprinkler Guard, (specify) finish, P/N (specify):

Red Painted	569371001
Zinc Chromate	569379001

### Model G5 Sprinkler Guard

Model G5 Sprinkler Guard is available only in Zinc Chromate finish.

Specify: Model G5 Sprinkler Guard, P/N 569389000

### Model G6 Sprinkler Guard

Specify: Model G6 Sprinkler Guard, (specify) finish, P/N (specify):

Red Painted	560001085
Zinc Chromate	560001084

### Model G1/S1 Sprinkler Guard with Shield

Specify: Model G1/S1 Sprinkler Guard with Shield, (specify) finish, P/N (specify):

Red Painted	569381066
Zinc Chromate	569389066

### Model G4/S3 Sprinkler Guard with Shield

Specify: Model G4/S3 Sprinkler Guard with Shield, (specify) finish, P/N (specify):

Red Painted	569371066
Zinc Chromate	569379066

### Model G6/S3 Sprinkler Guard with Shield

Specify: Model G6/S3 Sprinkler Guard with Shield, (specify) finish, P/N (specify):

Red Painted	560001095
Zinc Chromate	560001094

### Model WSG-2 Sprinkler Guard with Shield

Specify: Model WSG-2 Sprinkler Guard with Shield, (specify) finish, P/N (specify):

Red Painted	560001098
Zinc Coated	560001097

### Model S2 Sprinkler Shield

Model S2 Sprinkler Shield is available only in Plated Steel finish.

Includes S2 Shield and one O-Ring.

Specify: Model S2 Sprinkler Shield, (specify) Thread Size, P/N (specify):

1/2 in. NPT	560709332
3/4 in. NPT	560709342

### Model S4 Sprinkler Shield

Includes S4 Shield and two O-Rings.

Specify: Model S4 Sprinkler Shield, (specify) finish, (specify) Thread Size, P/N (specify):

#### Plain Brass

1/2 in. NPT	569521001
3/4 in. NPT	561521001

#### Chrome Plated

1/2 in. NPT	569529001
3/4 in. NPT	561529001

### Model S5 Sprinkler Shield

Model S5 Sprinkler Shield is available only in Brass finish.

Includes S5 Shield and two O-Rings.

Specify: Model S5 Sprinkler Shield, (specify) Thread Size, P/N (specify):

1/2 in. NPT	560156802
-------------	-----------

### Model WS-2 Sprinkler Shield

Specify: Model WS-2 Sprinkler Shield, (specify) finish, (specify) Thread Size, P/N (specify)

#### Red Painted

1/2 in. NPT	560001081
3/4 in. NPT	560001083

#### Zinc Coated

1/2 in. NPT	560001080
3/4 in. NPT	560001082

### Sprinkler Guard Installation Tool\*

Specify: Sprinkler Guard Installation Tool, P/N 560008597

\* For use with Model G1, G4, and G6 guards and Model G1/S1, G4/S3, and G6/S3 guards with shields only. A Sprinkler Guard Installation Tool is included with orders in original carton quantities.