



FX-64 and FX-1000 Technical Reference Manual

Copyright © 2022 Carrier. All rights reserved.

This document may not be copied in whole or in part or otherwise reproduced without prior written consent from Carrier, except where specifically permitted under US and international copyright law.

Trademarks and patents The FX-64 and FX-1000 name and Kidde logo are trademarks of Carrier. KESMobile is a trademark of Carrier.

Other trade names used in this document may be trademarks or registered trademarks of the manufacturers or vendors of the respective products.

FCC compliance Class A: This equipment has been tested and found to comply with the limits for a Class A digital device, pursuant to part 15 of the FCC Rules. These limits are designed to provide reasonable protection against harmful interference when the equipment is operated in a commercial environment. This equipment generates, uses, and can radiate radio frequency energy and, if not installed and used in accordance with the instruction manual, may cause harmful interference to radio communications. Operation of this equipment in a residential area is likely to cause harmful interference in which case the user will be required to correct the interference at their own expense.

Contact information For contact information, see www.kidde-esfire.com.

Content

Important information	iv
Minimum system requirements	vii
To get started	vii

Chapter 1	Installation and wiring	1
	Panel backbox installation	2
	Panel electronics installation	4
	Panel backbox wire routing	5
	AC power wiring	6
	Panel transformer wiring	7
	Battery wiring (TB8)	8
	Notification appliance circuit wiring (TB2)	10
	Addressable device loop wiring	12
	Alarm, trouble, and supervisory relay wiring (TB3)	17
	Remote annunciator wiring (TB4)	18
	Auxiliary/smoke power output wiring	20
	SA-DACT wiring	21
	SA-232 wiring	24
	SA-USB wiring	27
	SA-CLA wiring	29
	SA-ETH wiring	30
	CTM module wiring	31
	RPM module wiring	33
Chapter 2	Front panel programming	35
	UL/ULC programming requirements	37
	Getting started	38
	Device type descriptions	52
	Displaying the Program menu	61
	Setting the time and date	61
	Setting daylight saving time	62
	Changing the passwords	63
	Restoring the factory default settings	63
	Setting up the programmable keys	64
	Clearing the event history log	67
	Updating the firmware	68
	Restarting the panel	68
	Enabling RS-232 communication	69
	Auto programming the panel	69
	Performing incremental programming	76
	Adding and removing devices from programmed systems	79

Advanced programming 83

Chapter 3

System operation 133

Operation overview 135

LCD display screen 136

System LEDs 140

LED display expander LEDs 141

Control buttons 142

Component descriptions 147

Events with event messages 148

Event ID numbers and descriptions 151

Viewing event details 156

Resetting the panel 157

Silencing panel and annunciator buzzers 158

Silencing notification appliances 158

Conducting a lamp test 159

Activating and restoring output devices 160

Unlatching latched output devices 160

Activating and restoring panel NACs 161

Activating and restoring sensor bypass 162

Activating and restoring gas accelerated response 163

Disabling and enabling devices 165

Disabling and enabling zones 166

Disabling and enabling panel events 167

Disabling and enabling loop events 168

Disabling and enabling panel NACs 170

Disabling and enabling the dialer and network 170

Initiating a fire drill 171

Conducting a walk test 171

Chapter 4

Reports 175

Basic steps for viewing and printing reports 176

History report 176

Walk Test report 177

Device Maintenance report 178

System Status report 178

Correlation Groups report 179

Correlation Group Configuration report 179

Zone report 180

System Configuration report 180

Internal Status report 181

Device Details report 181

Diagnostics reports 181

Internal Fault report 183

Canceling a report 183

Chapter 5	Diagnostics, maintenance, and testing 185
	Preventive maintenance schedule 186
	Fast Ground Check 186
	Recalibrate device 186
	Flash Device LED 187
	Loop comm check 187
	Control panel testing 188
	Electronic testing of a device (test fire) 189
	SA-DACT testing 190
	Conducting a lamp test 191
	Starting and stopping a walk test 191
	Using HyperTerminal 193
	Replacing a device in alarm 194
Appendix A	Panel specifications 195
	Control panel specifications 196
Appendix B	Worksheets 199
	Battery calculation worksheet 200
	Notification appliance circuit calculations worksheet 205
	Notification appliance voltage drop calculation worksheet 211
	RZ116-2RS 24V IN riser maximum wire run calculation 213
	Device loop maximum wire length worksheet 214
	Correlation groups worksheet 218
	Device settings worksheet 219
	Loop worksheet 222
	Panel configuration worksheet 223
	Panel operation worksheet 226
	Zone settings worksheet 227
Appendix C	Applications 229
	CAN/ULC-S559 applications 230
	Local alarm signaling applications 233
	Correlated zone and system alarm signaling applications 237
	SA-FSB Building Management System Communication 242
	KESMobile and Web Portal System 242
	In-suite signal silence applications 243
	Index 247

Important information

Limitation of liability

This product has been designed to meet the requirements of NFPA 72 *National Fire Alarm and Signaling Code*, NFPA 720 *Standard for the Installation of Carbon Monoxide (CO) Detection and Warning Equipment*, UL 864 *Standard for Control Units and Accessories for Fire Alarm Systems*, and ULC-S527 *Standard for Control Units for Fire Alarm Systems*. Installation in accordance with this manual, applicable codes, and the instructions of the authority having jurisdiction (AHJ) is mandatory. Carrier shall not under any circumstances be liable for any incidental or consequential damages arising from loss of property or other damages or losses owing to the failure of Carrier products beyond the cost of repair or replacement of any defective products. Carrier reserves the right to make product improvements and change product specifications at any time.

While every precaution has been taken during the preparation of this manual to ensure the accuracy of its contents, Carrier assumes no responsibility for errors or omissions.

FCC compliance statement

This equipment can generate and radiate radio frequency energy. If the equipment is not installed in accordance with this manual, it may cause interference to radio communications. This equipment has been tested and found to comply with the limits for Class A computing devices pursuant to Subpart B of Part 15 of the FCC Rules. These rules are designed to provide reasonable protection against such interference when this equipment is operated in a commercial environment. Operation of this equipment is likely to cause interference, in which case the user, at their own expense, will be required to take whatever measures may be required to correct the interference.

SA-DACT FCC information

Cautions

- To ensure proper operation, this dialer must be installed according to the enclosed installation instructions. To verify that the dialer is operating properly and can successfully report an alarm, it must be tested immediately after installation, and periodically thereafter, according to the enclosed test instructions.
- In order for the dialer to be able to seize the phone line to report an alarm or other event when other customer equipment (telephone, answering system, computer modem, etc.) connected to the same line is in use, the dialer *must* be connected to a properly installed RJ-31X jack. The RJ-31X jack must be connected in series with, and ahead of, all other equipment attached to the same phone line. Series installation of an RJ-31X jack is

depicted in the wiring diagram. If you have any questions concerning these instructions, you should consult your telephone company or a qualified installer.

Testing

When programming emergency numbers or making test calls to emergency numbers, remain on the line and briefly explain to the dispatcher the reason for the call. When system maintenance, testing or modifications could result in the transmission of signals from the fire alarm system to a supervising station, consult the supervising station to determine the best time to send these signals (i.e., “off-peak” hours).

Compliance

- This dialer complies with Part 68 of the FCC rules and the requirements adopted by the Administrative Council for Terminal Attachments (ACTA). A label attached to the dialer contains, among other information, a product identifier in the format US:AAAEQ##TXXXX. If requested, this information must be provided to the telephone company.
- The plug and jack used to connect the dialer to the premises wiring and telephone network must comply with the applicable FCC Part 68 rules and requirements adopted by ACTA. The dialer must be connected to a compliant RJ-31X or RJ-38X jack using a compliant cord. If a modular telephone cord is supplied with the dialer, it is designed to meet these requirements. See installation instructions for details.
- A ringer equivalence number (REN) is used to determine how many devices you can connect to a telephone line. If the total REN value for all devices connected on a telephone line exceeds that allowed by the telephone company, the devices may not ring on an incoming call. In most (but not all) areas the total REN value should not exceed 5.0. To be certain of the total REN value allowed on a telephone line, contact the local telephone company.
- For products approved after July 23, 2001, the REN is part of the product identifier in the format US:AAAEQ##TXXXX. The digits ## represent the REN without a decimal point. Example: 03 is a REN of 0.3. For earlier products the REN is listed separately.
- If the dialer is harming the telephone network, the telephone company will notify you in advance that temporary discontinuance of service may be required. If advance notice isn't practical, the telephone company will notify you as soon as possible. You will also be advised of your right to file a complaint with the FCC, if you believe it is necessary.
- The telephone company may make changes to its facilities, equipment, operations, or procedures that could affect the operation of the dialer. If this happens, the telephone company will provide advance notice in order for you to make necessary modifications to maintain uninterrupted service.
- If you are experiencing problems with the dialer, contact the manufacturer for repair or warranty information. If the dialer is harming the telephone network, the telephone company may request that you disconnect the dialer until the problem is resolved.
- The dialer contains no user serviceable parts. In case of defects, return the dialer for repair.

- You may *not* connect the dialer to a public coin phone or a party line service provided by the telephone company.

Industry Canada information

The Industry Canada label identifies certified equipment. This certification means that the equipment meets certain telecommunications network protective, operational, and safety requirements. Industry Canada does not guarantee the equipment will operate to the user's satisfaction.

Before installing this equipment, users should ensure that it is permissible to be connected to the facilities of the local telecommunications company. The equipment must also be installed using an acceptable method of connection. The customer should be aware that compliance with the above conditions may not prevent degradation of service in some situations.

Repairs to certified equipment should be made by an authorized Canadian maintenance facility designated by the supplier. Any repairs or alterations made by the user to this equipment, or equipment malfunctions, may give the telecommunications company cause to request the user disconnect the equipment.

Caution: Users should not attempt to make connections themselves, but should contact the appropriate electrical inspection authority, or electrician, as appropriate.

Users should ensure for their own protection that the electrical ground connections of the power utility, telephone lines, and internal metallic water pipe system, if present, are connected together. This precaution may be particularly important in rural areas.

Note: The Load Number (LN) assigned to each terminal device denotes the percentage of the total load to be connected to a telephone loop that is used by the device, to prevent overloading. The termination on a loop may consist of any combination of devices subject only to the requirements that the sum of the Load Numbers of all the devices does not exceed 100.

Minimum system requirements

The table below lists the minimum hardware requirements for each type of system for which the control panel is listed.

Table 1: Minimum hardware requirements for applications

System	Equipment needed
Protected Premises (Local) Fire Alarm System	Control panel Appropriately sized batteries
Auxiliary Fire Alarm System, Local Energy Type	Control panel Appropriately sized batteries CTM module
Remote Supervising Station Fire Alarm System	Control panel Appropriately sized batteries SA-DACT or RPM module
Central Station Fire Alarm System	Control panel Appropriately sized batteries SA-DACT or RPM module

To get started

If you are just starting out, follow the items in this checklist to prepare, install, wire, and program your fire alarm control panel.

WARNING: Electrocution hazard. Make sure that the AC power circuit breaker is off before connecting wires to the terminal block.

1. Prepare the site. Make sure the installation location is free from construction dust and debris and extreme temperature ranges and humidity.
2. Unpack the equipment.
3. Install the panel backbox. See “Panel backbox installation” on page 2 for backbox dimensions.
4. Install the panel electronics in the panel backbox. See “Panel electronics installation” on page 4.
5. Remove the clear protective plastic from the front panel display.
6. Install the optional panel accessories. Refer to each component’s installation sheet instructions.

7. Review Chapter 1 “Installation and wiring” starting on page 1.
8. Check the field wiring for opens, grounds, and shorts before connecting.
9. Connect AC power and ground wiring. See “AC power wiring” on page 6. The panel cannot be started on batteries only.
10. Connect panel low voltage wiring. See “Panel transformer wiring” on page 7.
11. Turn on AC power.
12. Connect the batteries. See “Battery wiring (TB8)” on page 8.
13. Program the panel. See Chapter 2 “Front panel programming” on page 35. If you are using the configuration utility, refer to the online help.
14. Test the system for proper operation.

Chapter 1

Installation and wiring

Summary

This chapter covers all control panel wiring, such as AC power, NACs, device loops, and battery wiring.

Content

Panel backbox installation	2
Panel electronics installation	4
Panel backbox wire routing	5
AC power wiring	6
Panel transformer wiring	7
Battery wiring (TB8)	8
Notification appliance circuit wiring (TB2)	10
Addressable device loop wiring	12
Alarm, trouble, and supervisory relay wiring (TB3)	17
Remote annunciator wiring (TB4)	18
Auxiliary/smoke power output wiring	20
SA-DACT wiring	21
SA-232 wiring	24
SA-USB wiring	27
SA-CLA wiring	29
SA-ETH wiring	30
Circuit specifications	30
CTM module wiring	31
RPM module wiring	33

Panel backbox installation

Note: Observe all applicable codes and standards, as well as AHJ and owner guidance when selecting a location for the panel installation.

The panel backbox can be surface mounted or semiflush mounted.

To surface mount the panel backbox:

1. Position the panel backbox on the finished wall surface.
2. Fasten the panel backbox to the wall surface where indicated in Figure 2 using fasteners that are suitable for the type of wall surface and weight of the backbox and panel, including standby batteries.
3. Route the field wiring through the designated knock-out locations to ensure separation of power-limited and non-power limited wiring.

Refer to “Panel backbox wire routing” on page 5.

To semiflush mount the panel backbox:

1. Frame the interior wall (as required) to support the entire weight of the fully installed control unit, including standby batteries.
2. Install a semiflush trim ring (optional) to the backbox.
For an FX64 backbox, use the SA-TRIM1 trim ring.
3. Route the field wiring through the designated knock-out locations to ensure separation of power-limited and non-power limited wiring.

Refer to “Panel backbox wire routing” on page 5.

4. Fasten the panel backbox to the framing studs where indicated.

Figure 1: Surface and semiflush mounting details

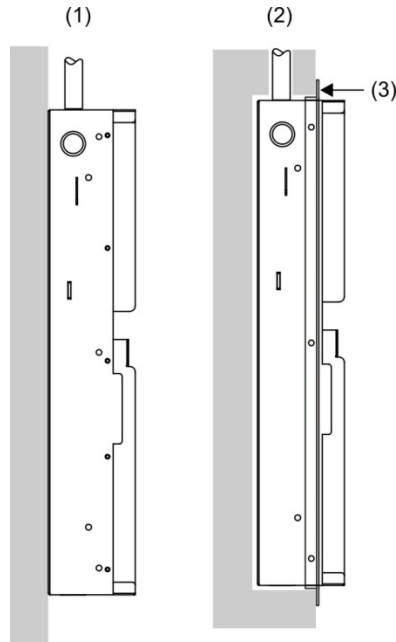

- (1) Surface mount
- (2) Semiflush mount

- (3) Trim skirt

Figure 2: Panel backbox, backbox with door, and backbox with door and trim ring attached

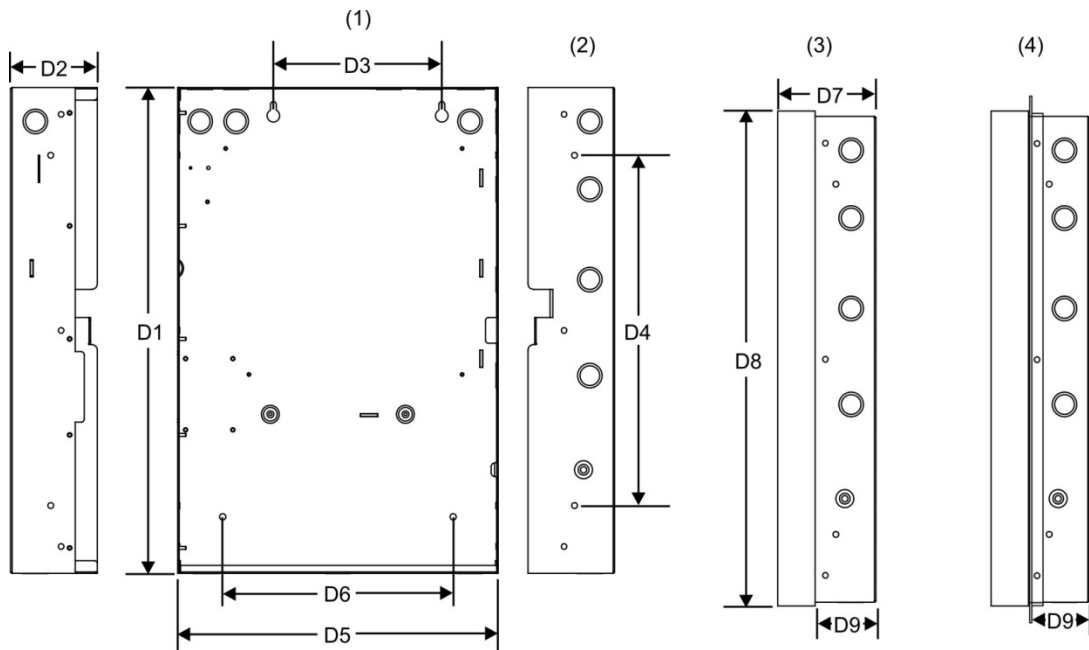

- (1) Surface mounting holes
- (2) Semiflush mounting holes

- (3) Backbox with door attached
- (4) Backbox with door and trim ring attached

Table 2: Backbox and backbox with door dimensions (in. and cm)

Model	D1 [1]	D2	D3	D4	D5 [1]	D6	D7	D8	D9
FX-64	21.50	3.85	7.5	15.50	14.25	10.25	3.9	21.7	2.7
	(54.6)	(9.8)	(19)	(39.4)	(36.2)	(26.0)	(9.9)	(55.1)	(6.8)
FX-1000	28.0	3.85	9.0	22.0	15.75	10.25	3.9	28.2	2.7
	(71.1)	(9.8)	(22.8)	(55.8)	(40.0)	(26.0)	(9.9)	(71.6)	(6.8)

[1] Add 1-1/2 in. (3.81 cm) to D1 and D5 dimensions for trim kit The trim kit provides .75 inches (1.9 cm) of trim to the top, bottom, and sides of the panel backbox.

Panel electronics installation

WARNING: Electrocution hazard. To avoid personal injury or death from electrocution, remove all sources of power and allow stored energy to discharge before installing or removing equipment.

The panel electronics are packaged separately from the backbox to prevent damage during backbox installation. The control unit electronics are factory assembled to a plastic mounting chassis and must be installed in the panel backbox to maintain the system's NRTL listing.

Notes

- Be sure that any possibility for construction damage and vandalism has passed before installing the panel electronics.
- Install the panel electronics only after backbox fastening and infrastructure connections are complete and all required system wiring for connection to the panel has been pulled into the backbox.

To install the panel electronics in the backbox:

1. Place the panel electronics in the panel backbox, so the four threaded studs in the backbox protrude through the holes in the corners of the backplane. Use the 10-24 nuts provided with the panel electronics to secure the backplane.
2. Mount and connect the panel option modules (SA-DACT, SA-ETH, SA-232, SA-USB, FX-SLC1, and FX-SLC2, SA-CLA and D16L-FA, etc.) to the main panel electronics or backplane.

Figure 3: Panel electronics installation

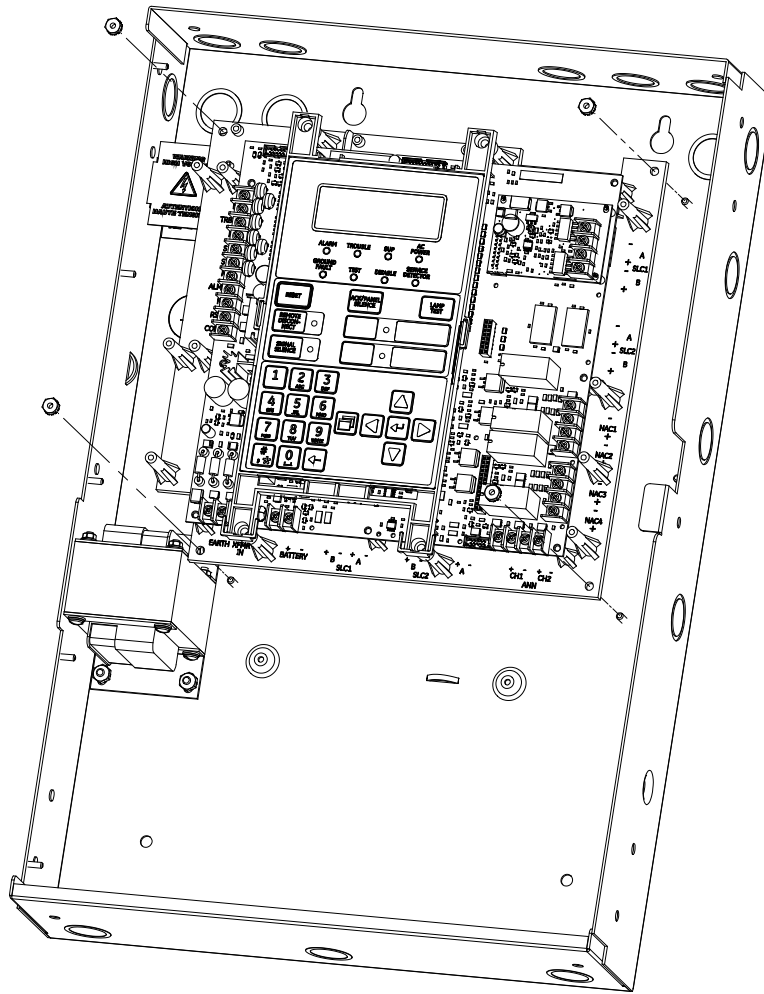

Panel backbox wire routing

Using the diagram below, keep power-limited wiring in the shaded area and nonpower-limited wiring in the unshaded area at all times.

Figure 4: Panel backbox wire routing

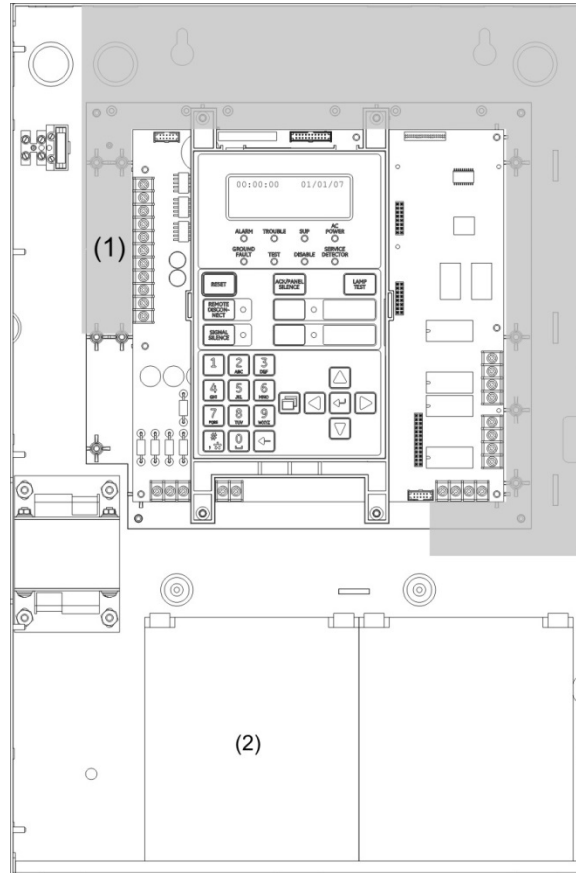

- (1) Power-limited only when connected to a power-limited source. If connected to a nonpowerlimited source, all wiring on terminal block TB3 must be NPFPL, NPFPLR, or NPFPLP rated wire or equivalent, in accordance with the NFPA 70 National Electrical Code and routed separately from all power-limited wiring.
- (2) Other than battery wiring, no other wiring shall be routed through the battery storage area when batteries are installed in this enclosure.

AC power wiring

Circuit specifications

- FX-64 panel: 120 V, 60 Hz, 1.3 A or 230 V, 50/60 Hz, 0.62 A from dedicated branch supply
- FX-1000 panel: 120 V, 60 Hz, 2.0 A or 230 V, 50/60 Hz, 0.97 A from dedicated branch supply

WARNING: Electrocution hazard. To avoid personal injury or death from electrocution, remove all sources of power and allow stored energy to discharge before installing or removing equipment. Never replace the fuse while the circuit is energized. The replacement fuse must be of equivalent size and type.

Caution: The middle connection (EARTH GND) on the terminal block makes a mechanical connection to the chassis even with the ground wire removed.

Terminate the incoming AC power wiring as shown in Figure 5.

Figure 5: AC power wiring

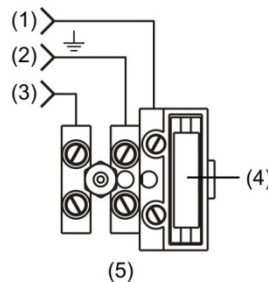

- | | |
|---------------------------------------|---|
| (1) Line | (4) 5 A, 250 V, SLO-BLO (Littelfuse
P/N 2450005) |
| (2) Earth ground | (5) 120 or 230 VAC primary power connection |
| (3) Neutral (120 VAC), Line (230 VAC) | |

Note: See “Component descriptions” on page 147 for the location of the wiring block in the backbox.

Panel transformer wiring

WARNING: Electrocution hazard. To avoid personal injury or death from electrocution, remove all sources of power and allow stored energy to discharge before installing or removing equipment.

Incoming power circuit specifications

- FX-64 panel: 120 V, 60 Hz, 1.3 A or 230 V, 50/60 Hz, 0.62 A from dedicated branch supply
- FX-1000 panel: 120 V, 60 Hz, 2.0 A or 230 V, 50/60 Hz, 0.97 A from dedicated branch supply

Low voltage circuit specifications

- Circuit voltage: 24 VAC
- All circuits are power-limited unless otherwise noted

Terminate the primary and secondary transformer wiring as shown in Figure 6 and Figure 7.

Figure 6: Transformer secondary wiring location

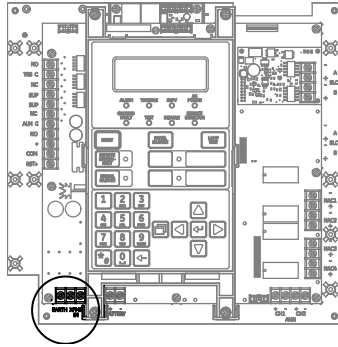
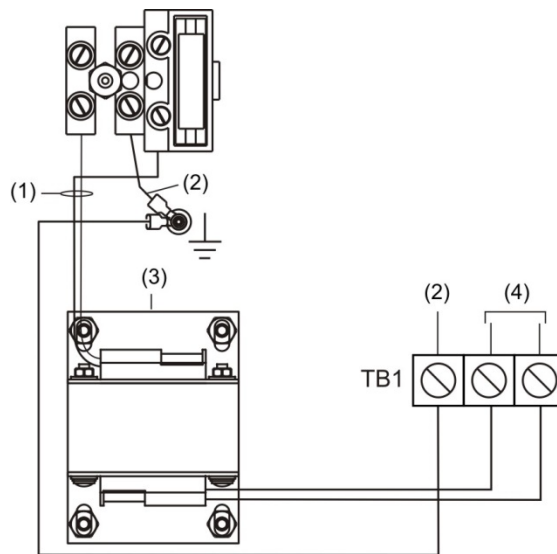

Figure 7: Transformer primary and secondary wiring



- (1) 120 or 230 VAC IN
- (2) Earth ground

- (3) Transformer
- (4) 24 VAC IN

Battery wiring (TB8)

Caution: Connect and disconnect standby batteries only with the AC power applied.

The control panel has a 24 VDC rechargeable battery circuit that is capable of charging up to two 12 VDC, 26 Ah sealed lead acid batteries.

The table below lists the batteries that can be installed in the control panel cabinets. Up to two 11 Ah batteries will fit in the FX-64 control panel cabinet and two 18 Ah batteries will fit in the FX-1000 point control panel cabinet. If larger batteries are required, you must use an approved battery cabinet. To determine which battery the system requires, use the “Battery calculation worksheet” on page 200, or use the System Builder (FX_Quote) program.

Table 3: Batteries for FX-64 and FX-1000 panels

Model	Rating
12V4A	12 volts, 4.5 Ah
12V6A5	12 volts, 7.2 Ah
12V10A	12 volts, 11 Ah
12V17A	12 volts, 18 Ah
12V24A	12 volts, 26 Ah

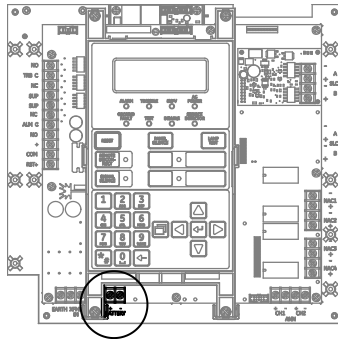
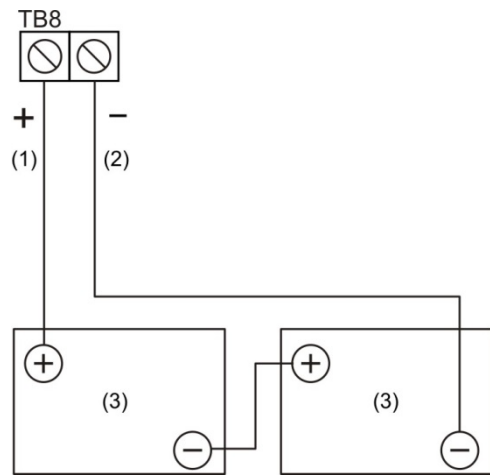
Figure 8: Battery wiring location**Figure 9: Battery wiring**

- (1) Red
- (2) Black

(3) 12 VDC battery

Notification appliance circuit wiring (TB2)

The control panel provides either two or four notification appliance circuits depending on which model you have. Each circuit can be individually configured for continuous, temporal, synchronized, coded, or city tie output.

Circuit specifications

- Class B or Class A.
- Circuit voltage: 24 VFWR, regulated
- Circuit current
- FX-64 panel:
 - 3.75 A total, 2.5 A max. per circuit at 120/230 VAC 60 Hz input voltage
 - 3.0 A total, 2.5 A max. per circuit at 230 VAC 50 Hz input voltage
- FX-1000 panel:
 - 6.0 A total, 2.5 A max. per circuit at 120/230 VAC 60 Hz input voltage
 - 5.0 A total, 2.5 A max. per circuit at 230 VAC 50 Hz input voltage
- Max. resistance: 26 Ω total
- Max. capacitance: 0.35 μ F
- EOLR: 15 k Ω , 1/2 W (P/N EOL-15), ordered separately
- Synchronization: For NACs wired Class A or Class B, signal synchronization is supported system-wide (all NAC circuits).
- Ground fault impedance: 0 to 5 k Ω
- Power-limited and supervised

Notes

- On the FX-64 panel, Class A wiring is available only when the optional SA-CLA expansion card is installed. Refer to the *SA-CLA Class A Interface Card Installation Sheet* (P/N 3101094) and to the topic "SA-CLA wiring" on page 29.
- Listed EOLRs must be installed as shown for proper supervision.
- Marking indicates the output signal polarity when the circuit is active. Polarity reverses when the circuit is not active. Wire notification appliances accordingly. Notification appliance polarity is shown in the active state.
- Installation limits are subject to acceptance by the AHJ.
- If the riser is used for more than one notification zone, install in accordance with the survivability from attack by fire requirements in NFPA 72 National Fire Alarm and Signaling Code.

Figure 10: NAC wiring location

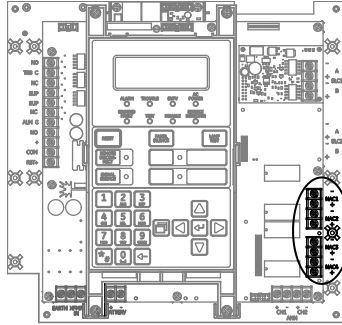

Figure 11: FX-64 panel Class B NAC wiring

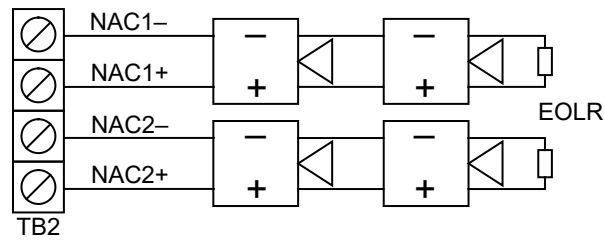

Figure 12: FX-1000 panel Class B NAC wiring

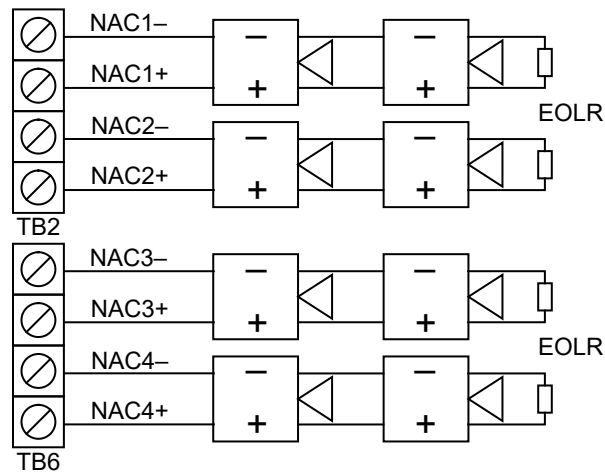
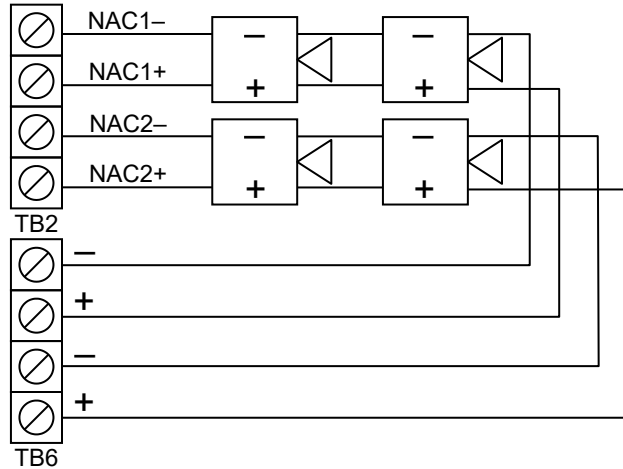

Figure 13: FX-1000 panel Class A NAC wiring



Note: For FX-64 Class A NAC wiring, see “SA-CLA wiring” on page 30.

Addressable device loop wiring

The FX-64 and FX-1000 control panels have addressable device circuits that you can use with addressable detectors and modules (Table 4). The FX-64 supports up to 64 detectors or modules. The FX-1000 accommodates two loop cards, and the loop cards can be a single loop or a dual loop. The FX-1000 supports up to 1,000 devices, depending on your configuration. The loop circuit is supervised for open circuits, short circuits, and ground faults.

Table 4: Total supported device addresses

Panel type	Number of loop cards installed	Loop card type	Total number of addresses supported
FX-64	1	FX-SLC1	64 (any combination of detectors or modules)
FX-1000	1	FX-SLC1	250 (125 detectors and 125 modules)
FX-1000	2	FX-SLC1 FX-SLC1	250 (125 detectors and 125 modules) 250 (125 detectors and 125 modules)
FX-1000	1	FX-SLC2	250 (125 detectors and 125 modules) 250 (125 detectors and 125 modules)
FX-1000	1 1	FX-SLC1 FX-SLC2	250 (125 detectors and 125 modules) 250 (125 detectors and 125 modules) 250 (125 detectors and 125 modules)
FX-1000	2	FX-SLC2 FX-SLC2	250 (125 detectors and 125 modules) 250 (125 detectors and 125 modules) 250 (125 detectors and 125 modules) 250 (125 detectors and 125 modules)

Note: For a complete list of devices that can be connected to this circuit, refer to *FX-64 and FX-1000 Series Compatibility List* (P/N 3102355).

Caution: The FX-2WIRE module cannot be used on a device loop with isolator modules or isolator bases.

Device address assignment

The device address assignment on each loop for the FX-1000 panel is as follows.

Table 5: Loop device address assignment

Device type	Available addresses
Detectors	Address 001 through address 125
Modules	Address 201 through address 325

Circuit specifications

- Class B/DCLB, Class A/DCLA, or Class X/DCLC
- Communication line voltage: Maximum 20.6 V peak-to-peak
- Circuit current: 0.5 A max.
- Allowable circuit resistance: 66 Ω max.
- Allowable circuit capacitance: 0.5 μ F max.
- Resistance between isolators: Limited only by overall wire run lengths
- Isolators: 64 maximum per loop (total both isolator bases and modules)
- Ground fault impedance: 0 to 5 k Ω
- Isolation voltage threshold: 3.0 VDC or less
- Power-limited and supervised
- Synchronization: Signal synchronization is supported on a system-wide basis (all device loops) when using an FX-NAC or FX-T3T4 addressable notification appliance circuit (NAC) modules and Genesis or Enhanced Integrity notification appliances.

Installation limits are subject to acceptance by the AHJ.

Figure 14: Device loop wiring location

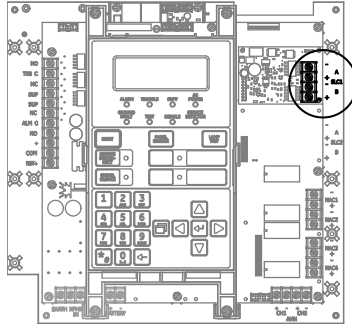
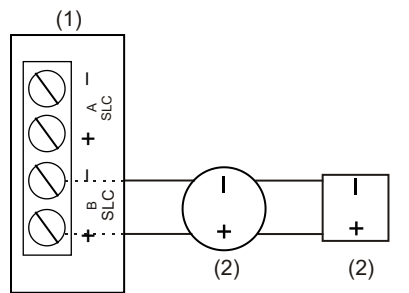

Figure 15: Class B/DCLB wiring



(1) Loop card

(2) Loop device

Figure 16: Class A/DCLA wiring [1]

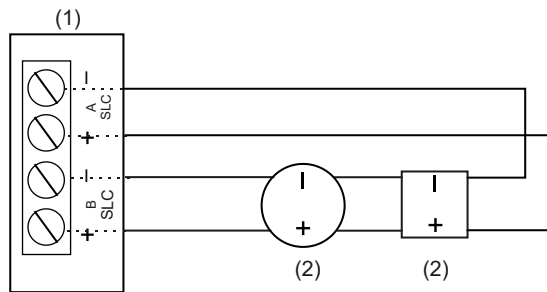

(1) Loop card

(2) Loop device

Figure 17: Class X/DCLC wiring [2]

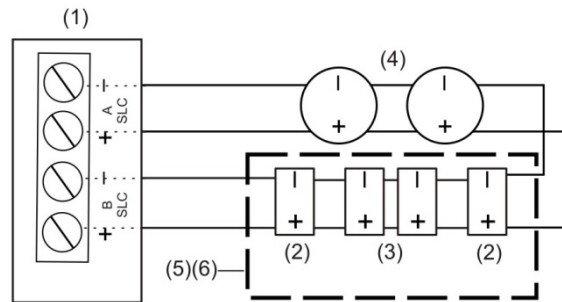

- (1) Loop card
 (2) Isolator module
 (3) SLC devices
 (4) SLC devices with an isolator base
 (5) UL/ULC listed enclosure
 (6) For Class X/DCLC wiring, un-isolated devices must be mounted in a cabinet with isolators on the incoming and outgoing wiring.

Notes for Figure 16 and Figure 17

[1] For Class A/DCLA wiring, isolator modules and isolator detector bases are required to prevent wire-to-wire shorts on the signaling line circuit wiring from adversely affecting other segments of the loop. Do not install more than 50 addressable devices between isolators, per NFPA 72.

[2] For Class X/DCLC wiring, isolator modules and isolator detector bases are required to prevent wire-to-wire shorts on the signaling line circuit wiring from adversely affecting any devices of the loop.

Loop card LEDs

There are two LEDs on the card for each SLC that indicate SLC communication status. See Figure 18 and Figure 19 for LED functions and location.

The installation location of the card on the panel determines what panel SLC the LEDs are associated with for FX-1000 that support dual SLC cards and provide two installation locations. See Figure 20.

Figure 18: Single SLC interface card LEDs (FX-64 and FX-1000 panels)

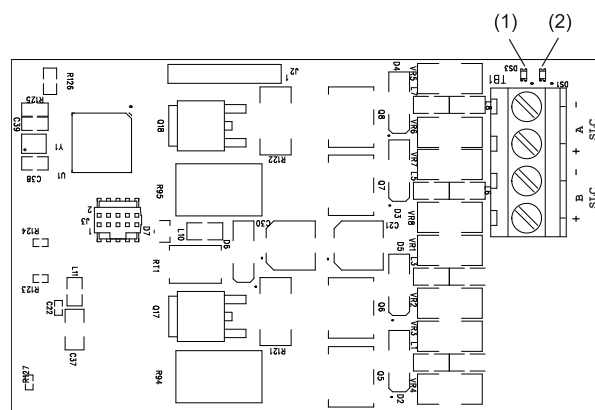

- (1) LED DS3: SLC fault: Solid ON to indicate an open fault. Flashes to indicate a short fault.
 (2) LED DS1: Device communication: Flashes to indicate normal device communications.

Figure 19: Dual SLC interface card LEDs (FX-1000 panels only)

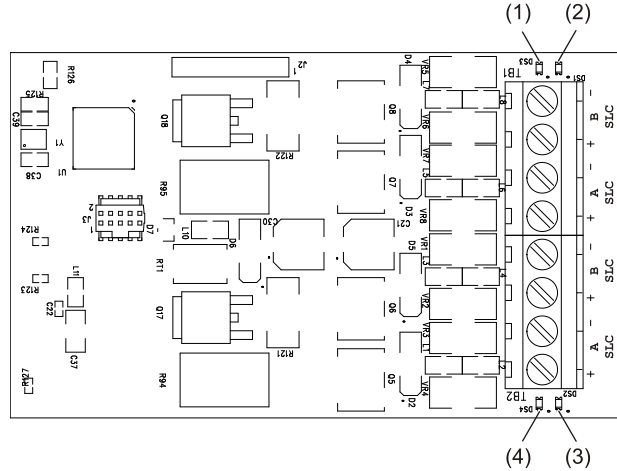

- (1) LED DS3: SLC fault: Solid ON to indicate an open fault. Flashes to indicate a short fault.
- (2) LED DS1: Device communication: Flashes to indicate normal device communications.
- (3) LED DS2: Device communication: Flashes to indicate normal device communications.
- (4) LED DS4: SLC fault: Solid ON to indicate an open fault. Flashes to indicate a short fault.

Figure 20: Panel SLC number configurations

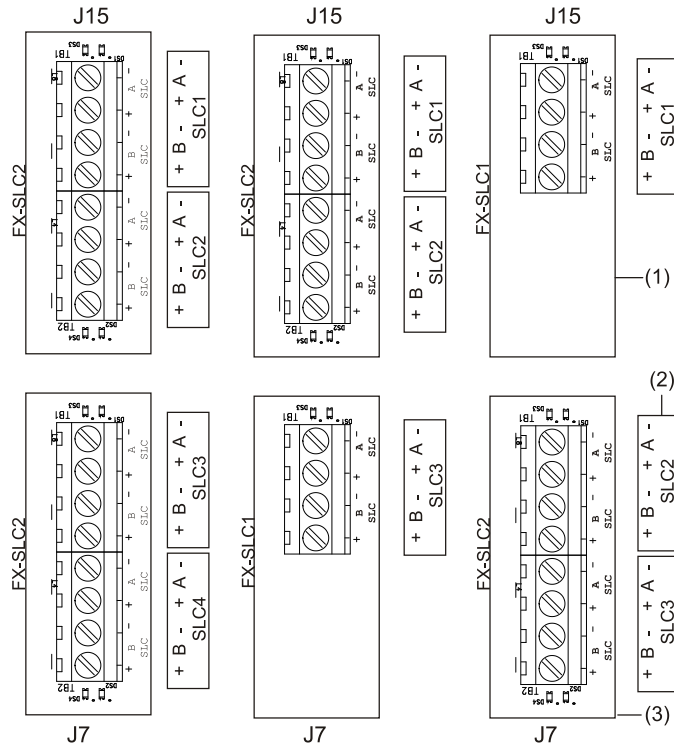

- (1) Connector J15 (primary position)
- (2) Panel label
- (3) Connector J7 (secondary position)

Alarm, trouble, and supervisory relay wiring (TB3)

The control unit provides three pre-programmed common event relays for alarm, supervisory, and trouble events. These relays are not field configurable.

- The trouble relay changes over on any trouble event (common trouble)
- The supervisory relay changes over on any supervisory event (common supervisory)
- The alarm relay changes over on any alarm event (common alarm)

Note: Relay circuits can only be connected to power-limited sources. Relays are not supervised.

Relay specifications

- Alarm and trouble: Form C, 24 VDC at 1 A resistive, Class E
- Supervisory: Form A, 24 VDC at 1 A resistive, Class E

Figure 21: Terminal wiring location

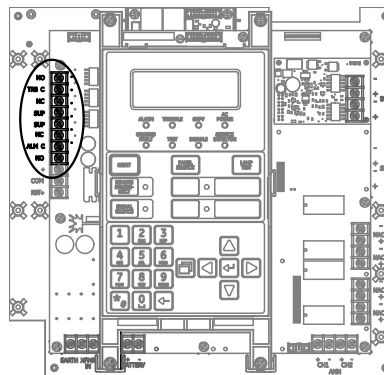
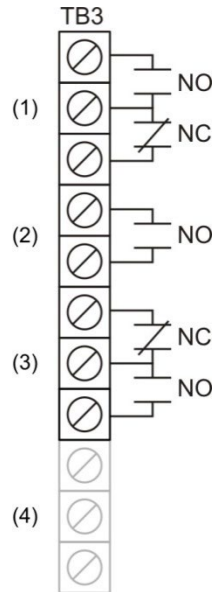

Figure 22: Relay wiring terminals



- (1) Common trouble relay
- (2) Common supervisory relay
- (3) Common alarm relay
- (4) Auxiliary/Smoke power output

Note: The figure above shows the panel in a normal state.

Remote annunciator wiring (TB4)

The control panel provides a connection for up to eight remote annunciators.

Circuit specifications

- Class B or Class A
- **Note:** The FX-64 panel requires the SA-CLA card to support Class A and redundant Class B circuits. Refer to “SA-CLA wiring” on page 30, or to installation sheet P/N 3101094.
- Circuit voltage: 2.55 V peak-to-peak average
- Circuit current: 30 mA max.
- Circuit resistance: 90 Ω
- Circuit capacitance: 0.3 μF
- Ground fault impedance: 0 to 5 kΩ
- RS-485 communications speed: 9600 baud
- Wiring: 18 to 14 AWG (1.0 to 2.5 mm²) twisted pair
- Wire run: 4,000 feet (1,219 m) max.
- Power-limited and supervised

Notes

- Refer to the *K-R Series Remote Annunciator Installation and Operation Guide* (P/N 3102382) for detailed wiring information.
- Installation limits are determined by the AHJ.

Figure 23: Remote annunciator wiring location

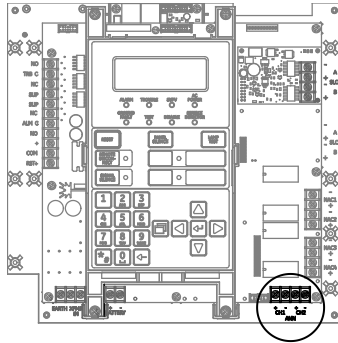
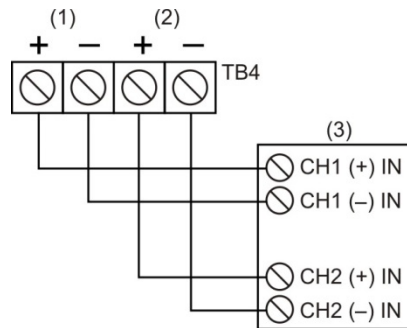

Figure 24: Annunciator channel wiring (Class A)



- (1) Channel 1
- (2) Channel 2

(3) Annunciator

Note: To use the Class A option, you must install the SA-CLA module in the FX-64.

Figure 25: Annunciator channel wiring (Class B)

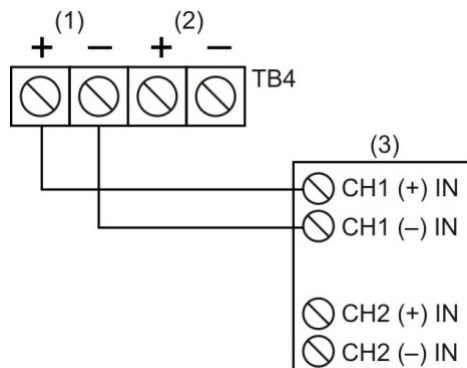

- (1) Channel 1
- (2) Channel 2

(3) Annunciator

Auxiliary/smoke power output wiring

The control panel provides resettable and continuous AUX power output circuits. Use the resettable AUX power output for devices such as four-wire detectors or beam detectors. Use the continuous AUX power output for devices such as remote annunciators or door holders.

Notes

- If you do not need resettable AUX power, you can configure the resettable AUX power output to supply continuous power.
- For a complete list of devices that can be connected to this circuit, refer to the *FX-64 and FX-1000 Series Compatibility List* (P/N 3102355).

Circuit specifications

- Circuit voltage range: 21.9 to 28.3 V
- AUX 1 + AUX 2 can supply 0.5 A of standby current. If more than 0.5 A of standby current is required, you must use a power-limited and regulated 24 VDC auxiliary/booster power supply that is UL/ULC and FM Listed (if the installation requires FM regulation) for fire protective signaling systems.
- Continuous circuit (AUX power 1): 24 VDC nominal at 500 mA (up to 1 Amp of alarm current is available on AUX 1 if you reduce the total available control panel NACs alarm current by the total amount of AUX 1 + AUX 2 alarm current over 500 mA).
- Resettable circuit (AUX power 2): 24 VDC nominal at 500 mA (standby and alarm). Use this circuit to provide 24 VDC resettable power. You can configure AUX power 2 as a continuous circuit if you do not need a resettable circuit.
- Special application circuits
- Ground fault impedance: 0 to 5 k Ω
- Supervised and power-limited

Figure 26: Auxiliary/smoke power wiring location

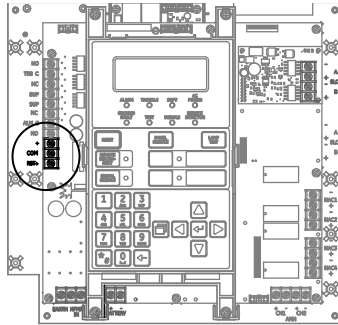
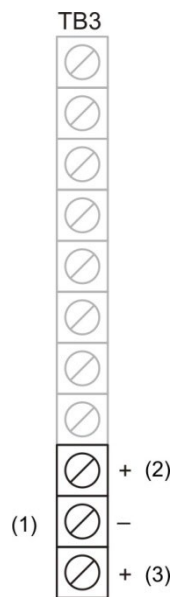

Figure 27: Auxiliary/smoke power output terminals



(1) Auxiliary/Smoke power output
 (2) Resettable (AUX 2)

(3) Continuous (AUX 1)

SA-DACT wiring

The optional SA-DACT provides communications between the control panel and the central station over a telephone line system. The SA-DACT is listed for use with the following DACRs.

Table 6: DACRs used with the SA-DACT

Receiver	Models	Formats
Ademco	685	Contact ID
FBII	CP220	Contact ID
Osborne-Hoffman	OH2000 and OH2000E with an OH2000E-LC line card installed (see note below)	Contact ID
Bosch	D6600	Contact ID
Silent Knight	9500, 9800	Contact ID
Sur-Gard	MLR1, MLR2, MCDI TLR, TLR+, SG-SLR, MLR2000	Contact ID

Phone lines connect to the dialer using connectors on the dialer's main circuit board. Phone line 1 connects to connector J1 and phone line 2 connects to connector J4.

The SA-DACT comes with two, eight position, four conductor modular cords. Connect one end of each cord to connector J1 and J2. Connect the other end of each modular cord to either an RJ-31X or RJ-38X. Wire the RJ-31X block as shown in Figure 29.

Note: Install a listed secondary telephone protector between the telco network and the SA-DACT card. The SA-DACT card must be the next piece of equipment that connects to the telephone company (TELCO) telephone lines.

Circuit specifications

- Operating current (standby or alarm): 41 mA nominal, 100 mA max.
- Phone line type: One or two loop-start lines on a public, switched network
- Phone line connector: RJ-31/38X (C31/38X)
- Communication format: Contact ID (SIA DC-05)

Figure 28: SA-DACT wiring location

Figure 29: SA-DACT wiring



- | | |
|---|---|
| (1) TELCO Line 2 | (7) Telephone protector |
| (2) Tip | (8) RJ-31X block (supplied by installer) |
| (3) Ring | (9) 8-position, 4-conductor modular cords
(supplied by the customer) |
| (4) Protected premises punch down block | (10) LINE 1 |
| (5) PBX | (11) LINE 2 |
| (6) TELCO Line 1 | |

SA-232 wiring

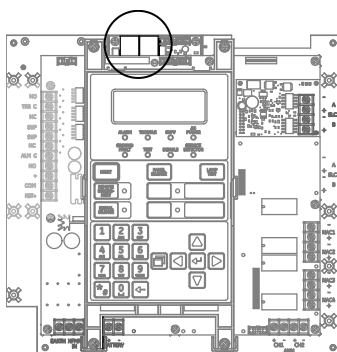
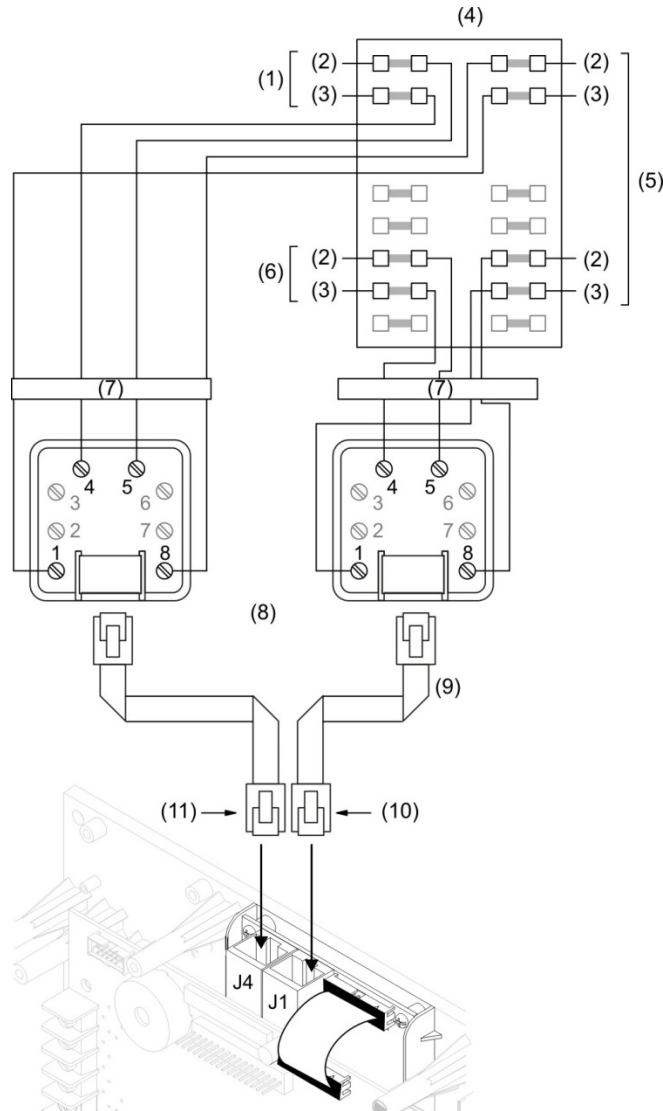
The optional SA-232 card can be wired to a printer to print system events or wired to a computer to read from and write to the panel using the configuration utility.

Circuit specifications

- Serial communications
 - Asynchronous communications maximum resistance: 13 Ω
 - Maximum capacitance: 0.7 μF
- Wire length: 50 feet max.
- Signal voltage: $\pm 10\text{ V}$
- Operating current (standby or alarm): 13 mA nominal, 20 mA max.
- Printer communication speed: 9600 baud
- Power-limited and unsupervised. Supervised when the Supervised Printer panel programming option is enabled.

Figure 30: SA-232 wiring terminals

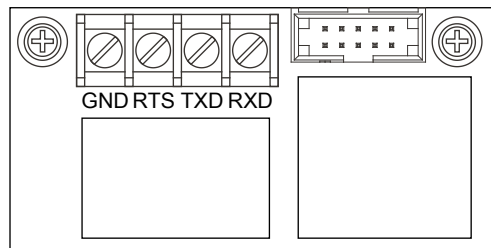

Printer wiring

Notes

- The printer must be configured through programming for proper operation.
- A USB to serial converter may be required for the following procedure.

To install wiring to a printer:

1. Locate the serial port on the back of the printer.
2. Connect the DB-25 end of the RS-232 cable to the serial port on the back of the printer.
3. Connect the other end of the RS-232 cable to the RS-232 card.

Figure 31: Printer wiring

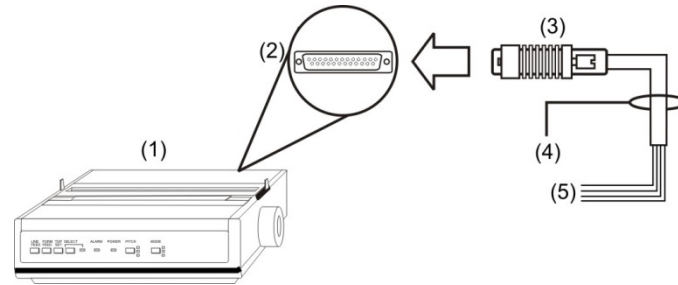

- (1) Printer
 (2) DB-25 serial port on back of printer
 (3) DB-25 male
 (4) RS-232 cable
 (5) To RS-232 card

Figure 32: DB-25 pin connections

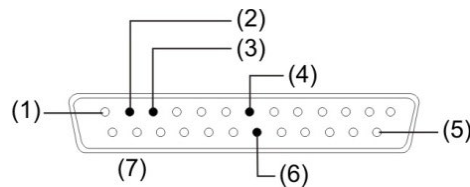

- (1) Pin 1
 (2) Pin 2: TXD (red wire)
 (3) Pin 3: RXD (white wire)
 (4) Pin 7: COM (black wire)
 (5) Pin 25
 (6) Pin 20: DTR (green wire)
 (7) DB-25 male (front view)

Table 7: SA-232 card to printer DB-25 connections

SA-232 card	DB-25	Description
GND	COM (pin 7)	Black wire (ground connection)
RTS	DTR (pin 20)	Green wire (printer supervision)
TXD	RXD (pin 3)	White wire (communication)
RXD	TXD (pin 2)	Red wire (communication)

Computer download wiring

To install wiring to a computer:

1. If you have a connected printer, disconnect it.
2. Locate a serial port (COM port) on the back of the computer.
Note: A USB to DB-9 converter may be required, as most computers no longer include serial ports.
3. Connect the DB-9 end of the RS-232 cable to the COM port on the back of the computer.
4. Connect the other end of the RS-232 cable to the SA-232 card.

Figure 33: Computer download wiring

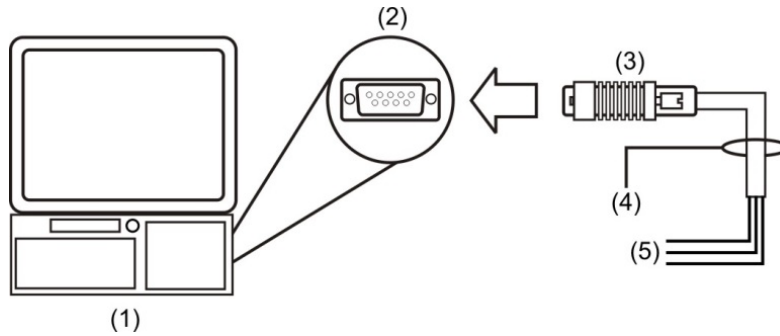

- (1) Computer
- (2) DB-9 COM port on back of computer
- (3) DB-9 female
- (4) RS-232 cable
- (5) To RS-232 card

Note: A preassembled 9-pin-to-spade-lug cord (P/N 260097) can be ordered from a Kidde distributor.

Figure 34: Pin designations on female DB-9 plug (back view)

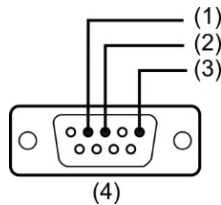

- (1) Pin 2 RXD
- (2) Pin 3 TXD
- (3) Pin 5 COM
- (4) DB-9 plug

Table 8: SA-232 card to computer DB-9 connections

SA-232 card	DB-9	Description [1]
GND	COM (pin 5)	Black wire (ground connection)
RTS	-	Not used
TXD	RXD (pin 2)	White wire (communication)
RXD	TXD (pin 3)	Red wire (communication)

[1] Wire colors refer to Model 260097 RS-232 cable

SA-USB wiring

The optional SA-USB card can be connected to a printer to print system events or connected to a computer to read from and write to the panel using the configuration utility.

Specifications

- The printer must be enabled and configured through programming for proper operation.
- Do not install JP1 (item 2, Figure 35). If jumper JP1 is installed (placed on both pins), the printer will not function. The panel will only display a printer trouble if the mode is set to supervised.
- Operating current (standby or alarm): 14 mA nominal, 20 mA max.
- Printer communication speed: 9600 baud
- Power-limited and unsupervised. Supervised for a single open and positive ground when the Supervised Printer panel programming option is enabled.
- Locate unsupervised USB printers in the same room and within 20 ft. (6.1 m) of the equipment to which they connect. Enclose wiring in conduit or equivalent protection against mechanical injury.
- Locate supervised USB printers in the same room as the equipment to which they connect.

Printer wiring

To wire to a printer:

1. If you have a computer connected to the SA-USB card, disconnect it.
2. Locate the USB port on the back of the printer. Refer to *PT-1S Fire Alarm Printer Installation Sheet*, (P/N 3100989) for details.
3. Connect a USB 2.0 A-to-B cable, purchased separately, to the printer USB port.
4. Connect the other end of the USB 2.0 cable to the SA-USB card, connector J3 (Item3, Figure 35).
5. If installed on both pins, remove jumper JP1 (item 2, Figure 35 on page 28) from one pin on the SA-USB card as shown in Figure 35 on page 28.

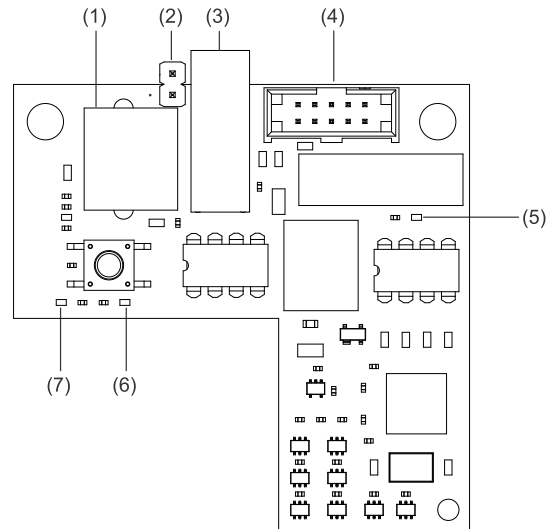
Figure 35: SA-USB jumper, LEDs, and connectors**Table 9: SA-USB jumper, LEDs, and connectors**

Item	Label	Description
(1)	J4	USB 2.0, Type B device port: Used as a temporary connection to a PC.
(2)	JP1	Programming jumper: Shown in the not installed position. When installed over both pins, the jumper is used during programming the SA-USB to update firmware. This can <i>only</i> be accomplished with assistance from Edwards Technical Support.
(3)	J3	USB 2.0, Type A host port: Used to connect supported printers.
(4)	J1	Used to connect the SA-USB to the panel electronics board.
(5)	DS2	TXD LED: Used to indicate all communications to the panel for both the printer and all PC applications.
(6)	DS1	RXD LED: Used to indicate all communications from the panel for both the printer and all PC applications.
(7)	DS4	TRBL LED: Used to indicate when it detects any printer trouble, such as off-line, out of paper, or the printer disconnected.

Note: The panel will only display a printer trouble if the mode is set to supervised.

Computer wiring

To wire to a computer:

1. If you have a printer connected to the SA-USB card, disconnect it.
2. Locate a USB port on the computer.
3. Connect a USB 2.0 A-to-B cable, purchased separately, to the computer USB port.
4. Connect the other end of the USB 2.0 cable to the to the SA-USB card, connector J4 (item, 1, Figure 35).

SA-CLA wiring

The SA-CLA card is used to supply wiring for Class A NACs and redundant Class B remote annunciator circuits on FX-64 control panels.

Circuit specifications

- Operating current
Standby: 3 mA
Alarm: 60 mA max.
- Max. resistance: 26 Ω
- Max. capacitance: 0.35 μF
- Max. current: 2.5 A per circuit
- Ground fault impedance: 0 to 5 k Ω
- Power-limited and supervised

Figure 36: SA-CLA Class A NAC wiring

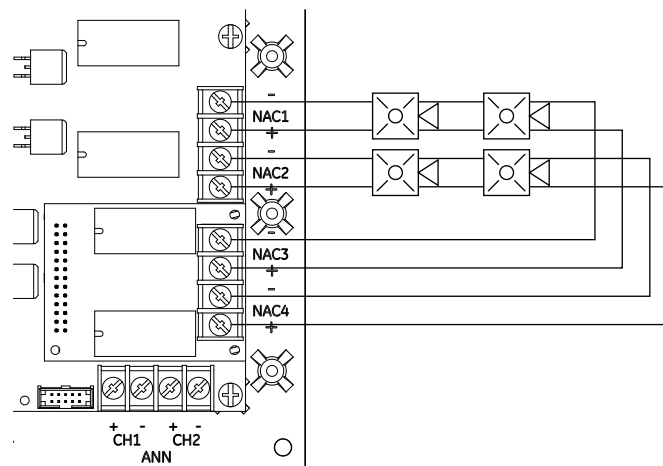
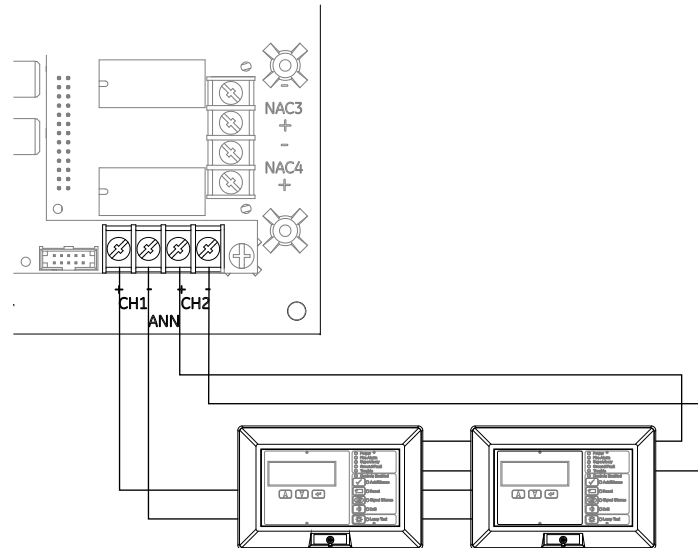

Figure 37: SA-CLA Redundant Class B remote annunciator circuit

SA-ETH wiring

The optional SA-ETH card provides a standard Ethernet network connection for connecting to a local network or connecting to a computer to read from or write to the panel using the configuration utility. The optional SA-ETH is required for TCP/IP communications between the panel and a computer operating the FireWorks software.

Circuit specifications

- Ethernet: 10/100BaseT
- Network cable: Cat 5/6 crossover cable or straight through cable
- Operating current (standby or alarm): 34 mA nominal, 41 mA max.
- Wire runs: 200 feet (60 m) max., Cat 5 cable (panel to communication equipment)

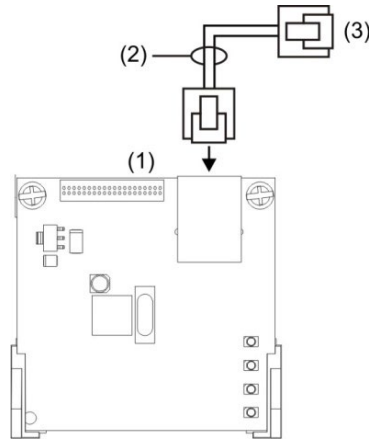
Figure 38: SA-ETH wiring

- (1) Ethernet card
(2) Network cable

(3) To network connection (PC, router, switch, etc.)

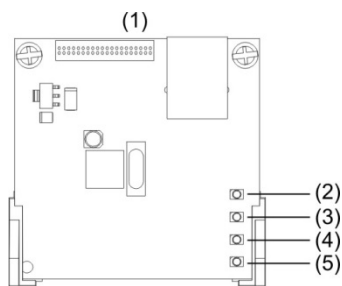
Figure 39: SA-ETH LEDs

- (1) Ethernet card
(2) LED 4 (DS4): Collision
(3) LED 3 (DS3): Duplex

(4) LED 2 (DS2): Speed
(5) LED 1 (DS1): Link

CTM module wiring

The City Tie Module (CTM) is an interface between the control panel notification appliance circuit and a master box. It provides off-premises signal transmission for systems that must comply with NFPA requirements for Auxiliary Protective Systems. The CTM activates a local energy fire alarm box. For detailed information and wiring, refer to *CTM City Tie Module Installation Sheet* (P/N 3101025).

Requirements

When connecting a CTM to the panel, the following hardware and programming requirements must be met:

- The CTM must be connected to either a panel NAC, or a NAC module

- The NAC used must be dedicated to CTM use only
- All alarm points or zones (if programmed as a zoned system) must be programmed to activate the dedicated NAC
- The NAC used must be programmed as City Tie

Wiring

The following wiring diagrams show how the polarity switches during an alarm condition.

Figure 40: CTM module wiring (panel in normal condition)

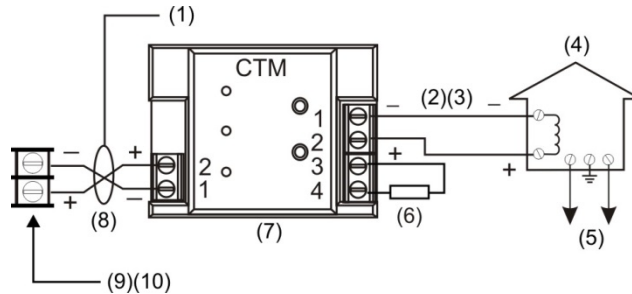

- | | |
|--|---|
| (1) Normal condition | (5) Public fire alarm reporting system |
| (2) 200 mA into a 14.5 Ω trip coil max. loop resistance = 25 Ω | (6) 15 kΩ end-of-line resistor |
| (3) This circuit is nonpower-limited and is supervised for grounds and opens, but not shorts | (7) CTM must be mounted in the same room as the panel |
| (4) Master box | (8) Supervised and power-limited |
| | (9) Notification appliance circuit (NAC) |
| | (10) NAC must be programmed for city tie |

Figure 41: CTM module wiring (panel in alarm condition)

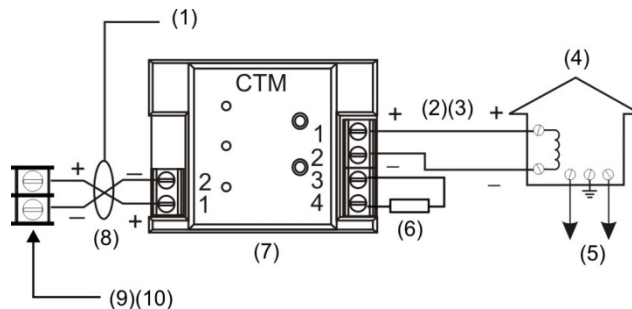

- | | |
|--|---|
| (1) Alarm condition | (5) Public fire alarm reporting system |
| (2) 200 mA into a 14.5 Ω trip coil max. loop resistance = 25 Ω | (6) 15 kΩ end-of-line resistor |
| (3) This circuit is nonpower-limited and is supervised for grounds and opens, but not shorts | (7) CTM must be mounted in the same room as the panel |
| (4) Master box | (8) Supervised and power-limited |
| | (9) Notification appliance circuit (NAC) |
| | (10) NAC must be programmed for city tie |

RPM module wiring

The Reverse Polarity Module (RPM) is an interface between the control panel and a reverse polarity receiver. It provides off-premises signal transmission for systems that must comply with NFPA requirements. When used as a reverse polarity remote station transmitter, it can be connected to either a single circuit (alarm or alarm and trouble) or up to three circuits (alarm, supervisory, and trouble). Below are application diagrams for using the RPM module. For detailed information and wiring, refer to *RPM Reverse Polarity Module Installation Sheet* (P/N 3100430).

Notes

- The RPM must be mounted in conduit, in an MFC-A enclosure, immediately adjacent to the panel.
- All relays are unsupervised and must be connected to a power-limited source.

Figure 42: Alarm transmitted only

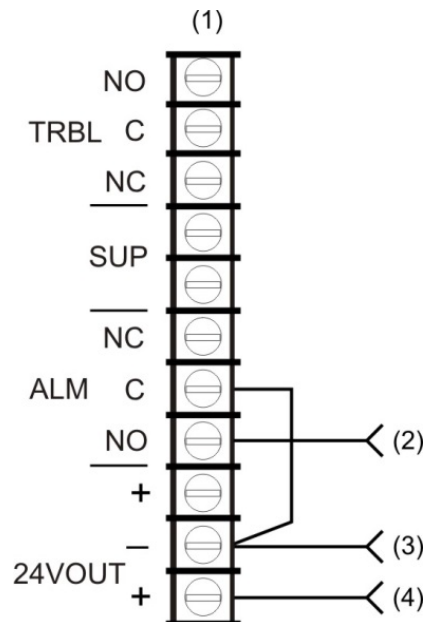

(1) Control panel TB3

(2) From ALRM on RPM (brown wire)

(3) From COM on RPM (black wire)

(4) From +24 on RPM (red wire)

Figure 43: Alarm and trouble transmitted on a single circuit

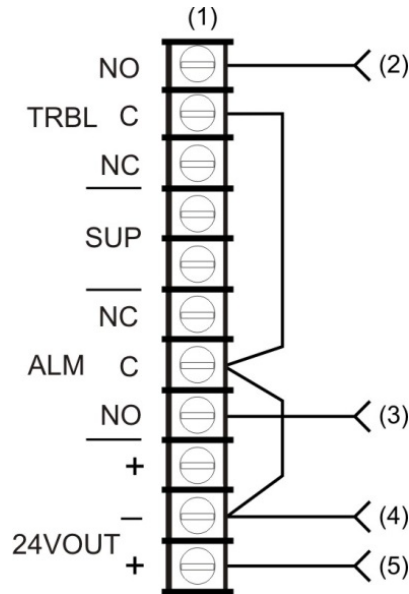

- (1) Control panel TB3
- (2) From TRBL on RPM (yellow wire)
- (3) From ALRM on RPM (brown wire)

- (4) From COM on RPM (black wire)
- (5) From +24 on RPM (red wire)

Note: JP1 on the RPM must be OUT.

Figure 44: Alarm, supervisory, and trouble transmitted on separate circuits

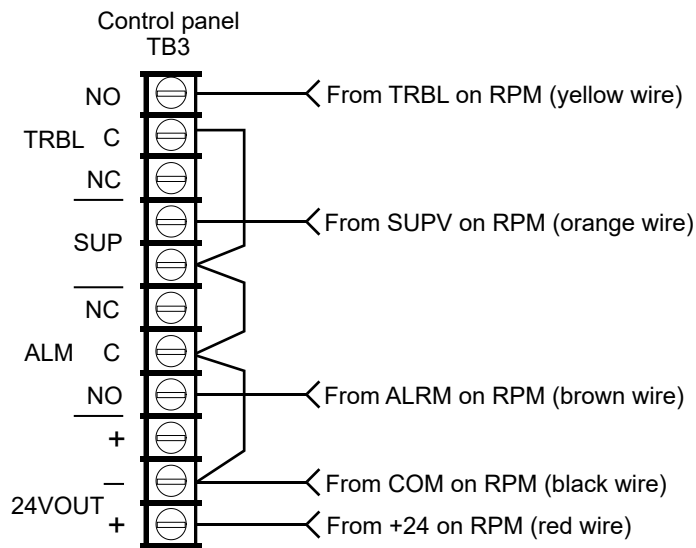

- (1) Control panel TB3
- (2) From TRBL on RPM (yellow wire)
- (3) From SUPV on RPM (orange wire)

- (4) From ALRM on RPM (brown wire)
- (5) From COM on RPM (black wire)
- (6) From +24 on RPM (red wire)

Note: JP1 on the RPM must be IN.

Chapter 2

Front panel programming

Summary

This chapter shows how to configure the system using the control buttons on the front panel. For information on programming the system using the optional Configuration Utility (CU), refer to the Help available in the CU.

The panel user interface is the primary interface of the fire alarm system.

Content

UL/ULC programming requirements	37
Getting started	38
What is a zone?	38
What is a correlation group?	39
What is in-suite signal silence?	41
Programming modes	41
Using the programming control buttons	42
Passwords	43
Factory default settings	43
Device type descriptions	52
Displaying the Program menu	61
Setting the time and date	61
Setting daylight saving time	62
Sample values for daylight saving time	62
Changing the passwords	63
Restoring the factory default settings	63
Setting up the programmable keys	64
Clearing the event history log	67
Updating the firmware	68
Restarting the panel	68
Enabling RS-232 communication	69
Auto programming the panel	69
Auto programming options	70

- Dialer options 73
- Auto programming procedure 74
- Labeling devices 75
- Labeling zones 75
- Performing incremental programming 76
 - Incremental programming options 76
 - Incremental programming procedure 77
 - Labeling devices 78
 - Labeling zones 78
- Adding and removing devices from programmed systems 79
 - Device programming options 79
 - Adding devices 81
 - Removing devices 82
- Advanced programming 83
 - Overview 83
 - Changing loop configuration options 84
 - Correlation group programming 85
 - Adding and removing panel events 88
 - Programming in-suite signal silence 90
 - Programming fast groups for sounder bases 90
 - Device programming 92
 - Programming relay and sounder detector bases 95
 - Programming relay modules and bases as latched output devices 96
 - Loops 1, 2, 3, and 4 enable loops 97
 - Loops 1, 2, 3, and 4 selecting loop classes 98
 - Zone programming 98
 - Panel programming 100
 - Central monitoring station device programming 104
 - Panel operation programming 120
 - Event programming 123

UL/ULC programming requirements

NOTICE TO USERS, INSTALLERS, AUTHORITIES HAVING JURISDICTION, AND OTHER INVOLVED PARTIES

This product incorporates field-programmable software. In order for the product to comply with the requirements of the listing agency, certain programming features or options must be limited to specific values or not used at all as indicated below.

Programmable feature or option	Possible settings	Listing Agency	Permitted (Y/N)	Permitted settings	Panel default
AC fail delay [1]	0 to 15 hours	UL, ULC	Y	1 to 3 hours	3 hours
Telephone line cut supervision duration	1 to 120 seconds	UL, ULC	Y	10 to 120 seconds	120 seconds
Transmission test frequency	0 to 240 hours	UL ULC	Y Y	6 hours 24 hours	6 hours 6 hours
Auto signal silence	Off or 5 to 30 minutes	UL ULC	Y N	5 to 30 minutes Off	Off
Dialer mode	Dual line Single line Modem only None	UL, ULC	Y	Dual line Single line [3] Modem only [4] None [4]	Dual line
Dialer retries	5 to 10	UL, ULC	Y	5 minimum	5 retries
Dialer retry time	1 to 45 seconds	UL, ULC	Y	Yes	5 seconds
Send event restore codes [2]	No or Yes	UL, ULC	Y	Yes	Yes
Swinger shutdown	Off or 1 to 255	UL, ULC	N	Off	Off
Zone resound	On or Off	UL, ULC	Y	On	On
Carbon monoxide (CO) signaling					
CO signaling correlation	Input: (CO element of the detector): CO Alarm CO Supervisory CO Monitor Output: Channel 2 of T3T4 module	UL, ULC	Y	Input: (CO element of the detector) [5]: CO alarm Output: Channel 2 of T3T4 module	No default correlation

Programmable feature or option	Possible settings	Listing Agency	Permitted (Y/N)	Permitted settings	Panel default
CO detector with a CO alarm device type					
Zone event notification Type	Alarm, Monitor, Supervisory, Waterflow	UL	Y	Alarm, Monitor, Supervisory, Waterflow	Alarm
	Alarm, Monitor, Supervisory, Waterflow	ULC	Y	Supervisory [6]	Alarm

[1] The programmed delay in reporting an AC fail condition is applicable only when system is normal (no events on the panel). If the system is in off-normal state (one or more events on panel), then the AC fail condition shall be reported immediately.

[2] Allowed only if the IDC is connected to the latching alarm device

[3] Allowed only when the supervising station supervises the telephone line and annunciates fault conditions within 200 seconds

[4] Prohibited when the control panel is connected to a supervising station

[5] CO alarm signals are required to activate TC4 CO evacuation signals but CO Supervisory or CO Monitor signals are not allowed to activate CO evacuation signals. CO alarm/CO supervisory/CO monitor signals shall not activate TC3 fire evacuation signals.

[6] CO detectors with a “CO alarm” device type must be programmed using zones with bicolor LEDs (zones 13 through 16 and 29 through 32) and the zone type must be set to Supervisory. The panel Event Notification must be set to Zone. Using this configuration ensures that when the “CO alarm” device type goes active, the panel displays a yellow LED indication instead of red. This configuration complies with CAN/ULC-S527.

Getting started

You can program the system using the command buttons on the front panel, or a PC with the optional configuration utility (CU), or both. If you plan to use the configuration utility, refer to the Help system for complete programming instructions.

What is a zone?

A zone is a defined area within a protected premises which contains individually addressed detector and/or module inputs physically located within that respective area. Zones provide a single initiation response to represent the group of contained devices in the same manner as a conventional initiating device circuit. Zones can be utilized to limit the number of event messages processed by the system. Zones are required to be defined when the system utilizes LED annunciation. Firewall designations, planned evacuation criteria, architectural design, and other factors determine how points are grouped into zones.

What is a correlation group?

A correlation group is a collection of inputs that activate a collection of outputs. During loop configuration, input devices, zones, and events are correlated with NACs and other output devices.

Output activations depend on the activation count and delay options. The activation count controls the number of input activations that are required to activate the group's outputs. The delay controls the number of seconds the system waits before activating the group's outputs. For example:

- When the correlation group's activation count is 1 (default), the activation of any input device in the group turns on every output device in the group.
- When the activation count is 3, every output device in the group is activated when at least three input devices activate.
- When the correlation group's activation count is 3 and three or more input devices turn on, the system waits the delay time before activating the group's outputs.

Figure 45: Correlation group operation

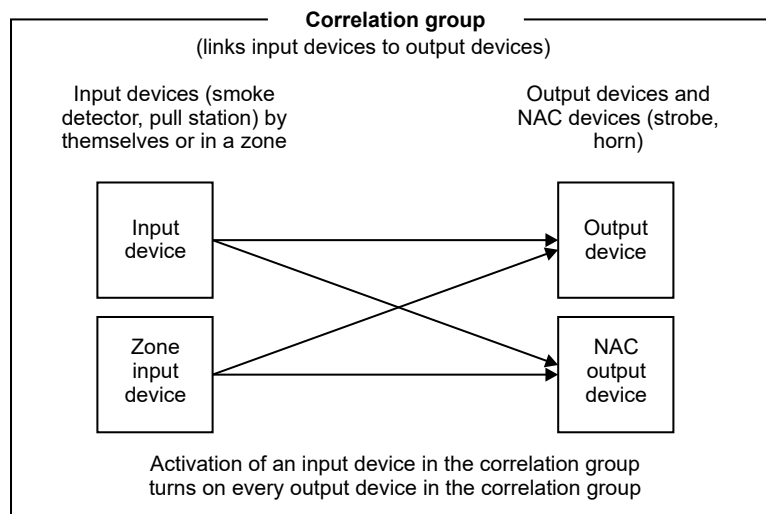

A correlation group can contain any combination of input devices, output devices, NACs, events, and zones. Input devices, output devices, NACs, events, and zones can be assigned to more than one correlation group. There are 199 available correlation groups.

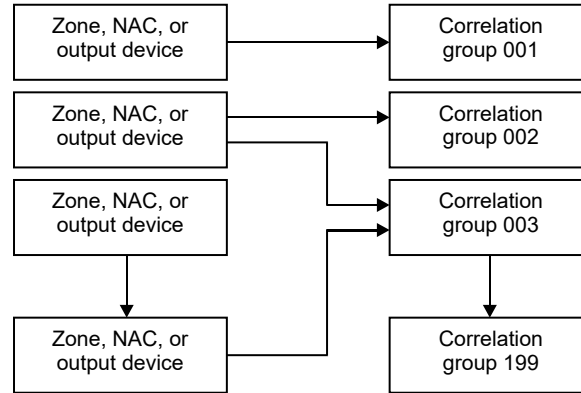
Figure 46: Inputs and outputs to correlation groups

During auto programming the following devices are assigned to correlation group 001:

- All addressable smoke detectors configured with the P1 or P2 switch in position 1 (alarm)
- All addressable pull stations
- All FX-2WIRE modules
- All FX-IDC1B modules
- Any circuit on an FX-IDC2B, or FX-IDC1A configured with the P1 or P2 switch in position 1 (alarm)
- All addressable primary elements of dual devices only. Example: PHCD is a multi-element device in which the smoke/heat element is included and the CO element is not.
- Circuit one on all FX-IDCWS modules
- All FX-NAC modules
- All panel NACs
- All zones configured as alarm

The following inputs are not included in correlation group 001 during auto programming:

- Relay and sounder bases with the Follow option set to Head. All sounder bases are programmed as Relay during auto programming.
- Addressable relays

Note the following:

- Any items included in correlation group 001 can be removed manually using front panel programming or the configuration utility.
- Any detectors, modules, or zones, where the type is changed to a type other than alarm, should be removed manually from correlation group 001 to avoid activating that correlation group.
- If zoning is used, the zones must be in the appropriate correlation group so devices assigned to that zone activate the correlation group.

- The CO elements for COD, PCD, HCD, and PHCD detectors are not included in Correlation Group 1 during auto programming or auto zoning

What is in-suite signal silence?

In-suite signal silence is a form of automatic alarm silencing that can be enabled for correlation groups. The function is used in residential complexes to minimize the annoyance of false alarms within living quarters. When an alarm input device activates, evacuation signals activate normally. After one minute, alarms in living quarters outside the alarm zone deactivate briefly. This interval is called the shutdown period and gives building personnel time to investigate the problem. Room evacuation signals in the alarm zone and hallway signals throughout the building remain active.

If the alarm has not been cleared within programmed allotted time (1 to 10 minutes), or if a subsequent alarm occurs, all signals resound. The shutdown period can be adjusted at the panel. In-suite signal silence can be turned off completely at the panel by setting the Suite Signal Silence option to Off (default). This setting is found at Program > Advanced Program > Panel Operation.

In-suite signal silence is a feature commonly utilized in the Canadian marketplace. This feature is not permitted when the system must meet UL 864 requirements for the US marketplace.

Notes

- Only alarm events can initiate in-suite signal silence.
- Only the first alarm is silenced by in-suite signal silence. Any additional alarms sound as programmed and are not automatically silenced.
- In-suite signal silence applies only to output devices and NACs that are configured as silenceable. It cannot be used in local alarm signaling applications.
- You cannot use a delay timer with in-suite correlation groups.
- No special hardware is required.
- In-suite signal silence is required by Ontario Building Code 3.2.4. For instructions on programming in-suite signal silence in a typical system, see “Adding and removing panel events” on page 88.

Programming modes

You can choose from three levels of program automation: Auto programming, incremental programming, or advanced programming. These are discussed in the following sections.

Auto programming

The Auto Program command is used to automatically configure the control panel and remote annunciators from their respective front panels.

Auto programming replaces the existing project database with a default project database based on the hardware configuration that it detects. The default project database configures the system as a general fire alarm system that activates all notification appliance circuits when any fire alarm input is activated.

Auto programming can also be used as a first step, to be followed by some advanced programming to customize individual settings. The Auto Program command lets you choose:

- Automatic zone assignments
- The event notification level to use
- Manual or automatic device and zone labeling during auto programming
- The “base follow” option for relay and sounder bases
- CMS network and dialer options

Note: Auto programming does not overwrite the previous CMS programming. However, the restore panel defaults option in the program menu does change the CMS configuration.

To auto program a panel, see “Auto programming the panel” on page 69.

Incremental programming

The Incremental Program command is used to make changes to a panel that has already been programmed. Incremental programming lets you add and label devices and zones in the existing database without affecting any other settings. See “Performing incremental programming” on page 76.

The Unconfigured Alarm command is used to add an additional device or several devices to a system without using the Incremental Program command. When a new device is added or a device is removed, the panel signals a “trouble active” event and indicates on the LCD that there is an unconfigured device. The device can then be programmed and added to the database. This method is typically used to add just a few devices. See “Adding and removing devices from programmed systems” on page 79.

Advanced programming

Advanced programming is used to apply custom programming to a new or previously programmed fire alarm system. Advanced programming lets you configure each option individually. See “Advanced programming” on page 83.

Using the programming control buttons

The following buttons are used with the LCD to program the panel.

Table 10: Programming control buttons

Button	Description
Arrow buttons	<p>Right arrow: Displays a submenu, or toggles between multiple settings such as “Yes” and “No.”</p> <p>Left arrow: Scrolls through a programming option’s selections</p> <p>Up arrow: Moves the cursor up</p> <p>Down arrow: Moves the cursor down</p>
Menu button	Opens and closes the main menu.
Enter button	Executes a command, displays a submenu, displays the Save function, or scrolls through a programming option’s selections.
Alphanumeric keypad	Used to enter numbers and letters needed for the various settings. Pressing and holding a key scrolls through alternate values. For example, pressing and holding the “2” key scrolls between 2, A, B, and C.
Cancel button	Returns to the previous menu level. Exits menu mode if you are at the highest menu level. Deletes text when editing labels, etc.

Passwords

There are two types of passwords available, Level 1 and Level 2.

Level 1: The level 1 password lets you access the front panel programmable buttons, change the system clock, activate and restore devices and NACs, disable and enable devices, NACs, events, and zones.

Level 2: The level 2 password lets you access the control panel’s programming functions. To prevent unauthorized access to the panel’s programming, always change the password from the default value and save it in a separate, secure location.

Note: If you are using the Configuration Utility (CU), the Level 2 password must match the panel Level 2 password.

Factory default settings

The panel is shipped from the factory with default settings. You can accept or change these settings as needed.

Note: Depending on panel equipment and programming, some of these settings may not be available.

Default passwords

The panel comes standard with a set of default passwords. These are:

- Level 1: 1111
- Level 2: 2222
- Remote annunciator: 3333

Note: We recommend that you change the default passwords after programming the system.

Default panel operation settings

- Language: English
 - Marketplace: US
 - AC fail delay: 3 hours
 - Zone resound: Yes
 - Reset inhibit: Off
 - Auto signal silence: Off
 - Suite signal silence: 10 minutes
 - Day start: 06:00
 - Night start: 18:00
 - Date format U.S.: MM/DD/YYYY
 - Aux reset: Yes
 - LCD banner: Blank
 - Event notification: Device
 - Key #1: NONE
 - Key #2: NONE
 - Standalone: No
-

Other default panel settings

- Daylight saving
 - Enabled: No
 - Month start: March
 - Month end: November
 - Week start: Second
 - Week end: First
 - Weekday start: Sunday
 - Weekday end: Sunday
 - Hour start: 2
 - Hour end: 2
 - Adjustment minutes: 60
- RS232 CU Enable: Off
- Lock remote read: No

Default panel configuration settings

IP Settings

- DHCP Mode: Yes
- DHCP Supervisory: No
- IP: 192.168.001.003
- Subnet mask: 255.255.255.0
- Gateway: 000.000.000.000
- DNS IP Settings
 - Pre: 192.168.001.001
 - Alt: 000.000.000.000
- DNS Dynamic: Yes
- DNS Supervisory: No
- PORT CU: 02505
- Cloud Conn: No
- Panel NACs
 - Class: Class B
 - Type: Continuous silenceable Correlation group: 1

- Event notification
 - Trouble > Printer: Yes
 - Trouble > Dialer: Acct 1
 - Trouble > NET (1-8): No
 - Trouble > CID: 321 (NAC1), 322 (NAC2), 326 (NAC3), 327 (NAC4)
 - Disable > Printer: Yes
 - Disable > Dialer: Acct 1
 - Disable > NET: Yes
 - Disable > CID: 521 (NAC1), 522 (NAC2), 526 (NAC3), 527 (NAC4)
 - Test > Printer: Yes
 - Test > Dialer: Acct 1
 - Test > CID: 600
 - Test > NET (1-8): No
- Annunciator class: Class B
- Annunciators (1-8)
 - Type: Off
 - Number expanders: None
 - Event notification
 - Trouble > Printer: Yes
 - Trouble > Dialer: Acct 1
 - Trouble > CID: 334
 - Trouble > NET (1-8): No
- Swinger shutdown: Off

- CMS device

CMS Path

Type: Telco only

Dialer

Type: Dual line

Acct 1 and 2

Account ID: FFFF

Primary receiver #: Blank

Secondary receiver #: Blank

Format: CID

Send Restorals: Yes

Retry Time: 05

Retry Count: 05

Evt Notif: Device

Send restorals: Yes

Retry time: 5 seconds

Retry count: 5

Event notification: Device

Test time: 03:11

Rings to answer: 5

Ring type: Any

Callback: Disabled

Callback #: Blank

Line 1 and 2

Dialing: Tone

Cut Duration/supervision: 120 sec.

Dial Tone wait: 10 seconds

Call disconnect seconds: Off

Test frequency hours: 6

Network

Network 1 to 8

Type: Sur-Gard

Enabled: No

Account ID: 0000

Hello Time: 0060

Timeout Secs: 00120

Max Attempts: 05

Send Restorals: Yes

Evt Notif: Device

DNIS Enable: No

DNIS Number: 0000000000

Primary Receiver

IP: 192.168.001.254

IP Port: 03061

Response Time: 005

Account Code: 0000000000

Secure Comm: Yes

Encryption Key: 0000000000000000

0000000000000000

Secondary Receiver:

Enabled: No

IP: 192.168.001.255

IP Port: 03061

Response Time: 005

Account Code: 0000000000

Secure Comm: Yes

Encryption Key: 0000000000000000

0000000000000000

Test Message:

Enabled: No

Normal: 160200000

Abnormal: 160800000

Test Freq: 01

Test Time: 12:00

Mask Mon Evnts:No

- Printer

Type: Unsupervised

Event notification

Trouble > Printer: Yes

Trouble > Coder: 00-00-00-00

Trouble > Dialer: Acct 1

Trouble > CID: 336

Trouble > NET (1-8): No

- Lock remote read: No

- AC voltage: 120

- Network (receiver)
 Enabled: No
 Account ID: FFFF
 IP: 192.168.1.254
 TCP/IP port: 9999
 Send restorals: Yes

Event notification: Device
 Hello time: 25
 Timeout: 40
 Receiver #: 2
 Line #: 2

Default loop configuration settings

- Loop class: Class B
- Zone
 Type: Alarm
 Correlation group: 001
 Notes
 - By default, NACs, zones, and most devices are assigned to correlation group 001.
 - Relay and sounder bases with the Follow option set to Head are not automatically assigned to correlation groups.
 Event notification
 Active > Printer: Yes
 Active > Dialer: Acct 1
 Active > NET (1-8): No
 Active > CID: 110
 Trouble > Printer: Yes
 Trouble > Dialer: Acct 1
 Trouble > NET (1-8): No
 Trouble > CID: 373
 Disable > Printer: Yes
 Disable > Dialer: Acct 1
 Disable > CID: 570
 Disable > NET (1-8): No
 Pre alarm > Printer: Yes
 Pre alarm > Dialer: None
 Pre alarm > NET (1-8): No
 Pre alarm > CID: 118
 Alarm verify > Printer: Yes
 Alarm verify > Dialer: None
 Alarm verify > NET (1-8): No
 Alarm verify > CID: 118
 Maintenance alert > Printer: Yes
 Maintenance alert > Dialer: Acct 1
 Maintenance alert > NET (1-8): No
 Maintenance alert > CID: 393
 Test > Printer: Yes
 Test > Dialer: Acct 1
 Test > CID: 614
 Test > NET (1-8): No
- Correlation Groups
 Add/remove zone > Zone: 01
 Add/remove zone > Status: Included
 Add/remove NAC > Panel NAC: 1
 Add/remove NAC > Status: Included
 Add/remove device > Device: 001
 Suite signal silence: No
 Activation count > Number: 01
 Copy > From group: 001
 Delay > Time: 000

- Device

Alt Operation: Yes

Day sensitivity: Least

Night sensitivity: Least

Day prealarm %: Off

Night prealarm %: Off

Base follow: Alarm

Follow CO: No

Zone: Off

Event notification

Active > Printer: Yes

Active > Dialer: Acct 1

Active > NET (1-8): No

Active > CID: 110

Alarm verify > Printer: Yes

Alarm verify > Dialer: None

Alarm verify > NET (1-8): None

Alarm verify > CID: 118

Disable > Printer: Yes

Disable > Dialer: Acct 1

Disable > NET (1-8): No

Disable > CID: 570

Maintenance Alert > Printer: Yes

Maintenance Alert > Dialer: Acct 1

Maintenance Alert > NET (1-8): No

Maintenance Alert > CID: 393

Pre alarm > Printer: Yes

Pre alarm > Dialer: None

Pre alarm > (1-8): No

Test > Printer: Yes

Test > Dialer: Acct 1

Test > NET (1-8): No

Test > CID: 614

Trouble > Printer: Yes

Trouble > Dialer: Acct 1

Trouble > NET (1-8): No

Trouble > CID: 373

Active3 > Printer: Yes [1]

Active3 > Dialer: Acct 1

Active3 > NET (1-8): No

Active3 > CID: 200

Correlation Groups

Base > Group: 001

Base > Status: Excluded

Base type: Standard

Follow: Head

Latched: No

Type: Heat alarm

Type (input device): Depends on type of device and marketplace

Type (output device): Genesis with audible/visible silence

Correlation group: 1

- Zone Secondary: Off
- Loop 2 enable: No
- Loop 2 Fst Grp: 1 to 25
- Loop 3 enable: No
- Loop 3 Fst Grp: 1 to 25
- Loop 4 enable: No
- Loop 4 Fst Grp: 1 to 25

[1] Active3 is an activation from a COD device, or an activation from the secondary element of a dual element detector (single address), such as PCD, HCD, or PHCD. See “Device type descriptions” on page 52.

Default contact ID event codes

Contact ID codes are used to report events that take place in the fire alarm system to a central monitoring station (CMS) via a dialer or over a network. The following table lists the default Contact ID (CID) codes for panel and loop events. Some events do not have CID codes. You can change the default code for an event or assign a code to an event that does not have one. See “Event programming” on page 123.

Table 11: Contact ID event codes

Event	CID	Event	CID
AC power (disable)	500	CO detected (alarm)	162
AC power (trouble)	301	Common alarm	110
Alarm active	110	Common disable	500
Alarm ON	115	Common monitor	140
Annunciator trouble	334	Common supervisory	200
Aux. power 1 (disable)	500	Common trouble	373
Aux. power 1 (trouble)	312	Common trouble for network dialer	373
Aux. power 2 (disable)	500	Common trouble for telco dialer	373
Aux. power 2 (trouble)	312	Date	625
Battery charger (disable)	500	Device trouble	373
Battery charger (trouble)	309	DHCP Communication Fault	354
Battery low (disable)	500	Device disable	570
Battery low (trouble)	302	Device pre alarm	118
Battery missing (disable)	500	Device alarm verify	118
Battery missing (trouble)	311	Device maintenance alert	393
Clear history	621	Device test	614
Cloud Provision Fault	354	Dialer disable/remote disconnect	551
Cloud Communication Fault	354	Dialer line 1 fault (disable)	500
Panel Certificate Fault	354	Dialer line 1 fault (trouble)	351

Event	CID
Dialer line 2 fault (disable)	500
Dialer line 2 fault (trouble)	352
Dialer deliver fail	354
Dialer normal test	602
Dialer abnormal test	608
Dialer configuration	354
DNS Communication Fault	354
Drill	601
Duct active	116
Ground fault (disable)	500
Ground fault (trouble)	310
Heat active	114
Internal fault	307
IP Dialer Account 1 Abnormal Test	608
IP Dialer Account 1 Normal Test	602
IP Dialer Account 2 Abnormal Test	608
IP Dialer Account 2 Normal Test	602
IP Dialer Account 3 Abnormal Test	608
IP Dialer Account 3 Normal Test	602
IP Dialer Account 4 Abnormal Test	608
IP Dialer Account 4 Normal Test	602
IP Dialer Account 5 Abnormal Test	608
IP Dialer Account 5 Normal Test	602
IP Dialer Account 6 Abnormal Test	608
IP Dialer Account 6 Normal Test	602
IP Dialer Account 7 Abnormal Test	608
IP Dialer Account 7 Normal Test	602
IP Dialer Account 8 Abnormal Test	608
IP Dialer Account 8 Normal Test	602
IP Gateway Trouble	354
Loop 1 device 000	008
Loop 1 initialization	000
Loop 1 fault (disable)	500

Event	CID
Loop 1 fault (trouble)	331
Loop 1 card fault (disable)	500
Loop 1 card fault (trouble)	333
Loop 1 Uncfgrd alarm (disable)	500
Loop 1 Uncfgrd alarm (active)	110
Loop 1 Uncfgrd trbl (disable)	500
Loop 1 Uncfgrd trbl (trouble)	331
Loop 1 over limits	331
Loop 2 device 000	018
Loop 2 initialization	000
Loop 2 fault (disable)	500
Loop 2 fault (trouble)	331
Loop 2 card fault (disable)	500
Loop 2 card fault (trouble)	333
Loop 2 Uncfgrd alarm (disable)	500
Loop 2 Uncfgrd alarm (active)	110
Loop 2 Uncfgrd trbl (disable)	500
Loop 2 Uncfgrd trbl (trouble)	331
Loop 2 over limits	331
Loop 3 device 000	028
Loop 3 initialization	000
Loop 3 fault (disable)	500
Loop 3 fault (trouble)	331
Loop 3 card fault (disable)	500
Loop 3 card fault (trouble)	333
Loop 3 Uncfgrd alarm (disable)	500
Loop 3 Uncfgrd alarm (active)	110
Loop 3 Uncfgrd trbl (disable)	500
Loop 3 Uncfgrd trbl (trouble)	331
Loop 3 over limits	331
Loop 4 device 000	038
Loop 4 initialization	000
Loop 4 fault (disable)	500
Loop 4 fault (trouble)	331

Event	CID
Loop 4 card fault (disable)	500
Loop 4 card fault (trouble)	333
Loop 4 Uncfgrd alarm (disable)	500
Loop 4 Uncfgrd alarm (active)	110
Loop 4 Uncfgrd trbl (disable)	500
Loop 4 Uncfgrd trbl (trouble)	331
Loop 4 over limits	331
Monitor active	140
NAC test	600
NAC1 trouble	321
NAC2 trouble	322
NAC3 trouble	326
NAC4 trouble	327
NAC1 disable	521
NAC2 disable	522
NAC3 disable	526
NAC4 disable	527
Net rcvr1 comm fault	354
Net rcvr2 comm fault	354
Net rcvr3 comm fault	354
Net rcvr4 comm fault	354
Net rcvr5 comm fault	354
Net rcvr6 comm fault	354
Net rcvr7 comm fault	354
Net rcvr8 comm fault	354
Net rcvr1 conf fault (disable)	500
Net rcvr1 conf fault (trouble)	354
Net rcvr2 conf fault (disable)	500
Net rcvr2 conf fault (trouble)	354
Net rcvr3 conf fault (disable)	500
Net rcvr3 conf fault (trouble)	354
Net rcvr4 conf fault (disable)	500
Net rcvr4 conf fault (trouble)	354
Net rcvr5 conf fault (disable)	500
Net rcvr5 conf fault (trouble)	354

Event	CID
Net rcvr6 conf fault (disable)	500
Net rcvr6 conf fault (trouble)	354
Net rcvr7 conf fault (disable)	500
Net rcvr7 conf fault (trouble)	354
Net rcvr8 conf fault (disable)	500
Net rcvr8 conf fault (trouble)	354
Net Receiver 1 Primary Communication Trouble	354
Net Receiver 1 Secondary Communication Trouble	354
Net Receiver 2 Primary Communication Trouble	354
Net Receiver 2 Secondary Communication Trouble	354
Net Receiver 3 Primary Communication Trouble	354
Net Receiver 3 Secondary Communication Trouble	354
Net Receiver 4 Primary Communication Trouble	354
Net Receiver 4 Secondary Communication Trouble	354
Net Receiver 5 Primary Communication Trouble	354
Net Receiver 5 Secondary Communication Trouble	354
Net Receiver 6 Primary Communication Trouble	354
Net Receiver 6 Secondary Communication Trouble	354
Net Receiver 7 Primary Communication Trouble	354
Net Receiver 7 Secondary Communication Trouble	354
Net Receiver 8 Primary Communication Trouble	354
Net Receiver 8 Secondary Communication Trouble	354
Test fire	604
Time	625

Event	CID
Walk test	607
Waterflow active	113
Zone active	110
Zone trouble	373
Zone disable	570

Event	CID
Zone pre alarm	118
Zone alarm verify	118
Zone maintenance alert	393
Zone test	614

Device type descriptions

Device types determine the operation of the points to which they are assigned. The following tables contain all possible device types. Available device types depend on the device and on the marketplace selected for the panel. Some device types are unavailable in some marketplaces. For this reason, the LCD listing for the selected device may differ from this table.

Some single address detectors have primary and secondary elements.

Table 12: Detectors with primary and secondary elements

Detector	Primary element	Secondary element
PCD	Smoke	CO
HCD	Heat	CO
PHCD	Smoke/Heat	CO

Table 13: Detector device types

Device type	Description
CO detectors (COD)	
Alarm	For CO (carbon monoxide) detectors that trigger an active CO alarm event. Detectors with this device type remain active until the condition that activated them is restored and the control panel is reset.
Monitor latching	For CO detectors that trigger a CO latching monitor event. Detectors with this device type remain active until the condition that activated them is restored and the control panel is reset.
Monitor nonlatching	For CO detectors that trigger a CO nonlatching monitor event. Detectors with this device type remain active until the condition that activated them is restored. Resetting the control panel is not required.
Supervisory latching	For CO detectors that trigger a CO latching supervisory event. Detectors with this device type remain active until the condition that activated them is restored and the control panel is reset.

Device type	Description
Supervisory nonlatching	<p>For CO detectors that trigger a CO nonlatching supervisory event.</p> <p>Detectors with this device type remain active until the condition that activated them is restored. Resetting the control panel is not required.</p>
Duct detectors (PDD)	
Duct alarm	<p>For duct smoke detectors. All activations are immediately considered as alarms. The panel and detector cannot be reset to normal until the smoke condition has cleared. [1]</p>
Duct supervisory (latching and nonlatching)	<p>Duct supervisory latching.</p> <p>Detectors with this device type when activated immediately places the panel in the supervisory state, turns on supervisory LEDs, and activates the supervisory relays. The detectors remain active until the smoke condition clears and the panel is reset.</p> <p>Duct supervisory nonlatching.</p> <p>Detectors with this device type when activated immediately places the panel in the supervisory state, turns on supervisory LEDs, and activates the supervisory relays. The detectors remain active until the smoke condition clears. Resetting the panel is not required.</p>
Heat and CO detectors (HCD)	
Heat + CO alarm	<p>For heat + CO detectors that trigger an active alarm event (fixed-temperature heat or CO).</p> <p>The panel and detector cannot be restored until devices are restored to normal and the panel is reset. [1]</p>
Heat + CO monitor latching	<p>For heat + CO detectors that trigger an active alarm event (fixed-temperature heat) or a CO latching monitor event.</p> <p>Detectors with this device type remain active until the condition that activated them is restored and the control panel is reset. [1]</p>
Heat + CO monitor nonlatching	<p>For heat + CO detectors that trigger an active alarm event (fixed-temperature heat) or a CO nonlatching monitor event.</p> <p>Detectors with this device type remain active until the condition that activated them is restored. Resetting the control panel is required to restore the heat type event. Resetting the control panel is not required for CO monitor nonlatching. [1]</p>
Heat + CO supervisory latching	<p>For heat + CO detectors that trigger an active alarm event (fixed-temperature heat) or a CO latching supervisory event.</p> <p>Detectors with this device type remain active until the condition that activated them is restored and the control panel is reset. [1]</p>
Heat + CO supervisory nonlatching	<p>For heat + CO detectors that trigger an active alarm event (fixed-temperature heat) or a CO nonlatching supervisory event.</p> <p>Detectors with this device type remain active until the condition that activated them is restored. Resetting the control panel is required to restore the heat type event. Resetting the panel is not required for CO supervisory nonlatching. [1]</p>

Device type	Description
Heat ROR + CO alarm	<p>For heat with rate of rise + CO detectors that trigger an active alarm event (rate-of-rise heat or CO).</p> <p>The panel and detector cannot be restored until devices are restored to normal and the panel is reset. [1]</p>
Heat ROR + CO monitor latching	<p>For heat with rate of rise + CO detectors that trigger an active alarm event (rate-of-rise heat) or a CO latching monitor event.</p> <p>Detectors with this device type remain active until the condition that activated them is restored and the control panel is reset. [1]</p>
Heat ROR + CO monitor nonlatching	<p>For heat with rate of rise + CO detectors that trigger an active alarm event (rate-of-rise heat) or a CO monitor nonlatching.</p> <p>Detectors with this device type remain active until the condition that activated them is restored. Resetting the control panel is required to restore the heat type event. Resetting the control panel is not required for CO monitor nonlatching. [1]</p>
Heat ROR + CO supervisory latching	<p>For heat with rate of rise + CO detectors that trigger an active alarm event (rate-of-rise heat) or a CO supervisory latching event.</p> <p>Detectors with this device type remain active until the condition that activated them is restored and the control panel is reset. [1]</p>
Heat ROR + CO supervisory nonlatching	<p>For heat with rate of rise + CO detectors that trigger an active alarm event (rate-of-rise heat) or a CO nonlatching supervisory event.</p> <p>Detectors with this device type remain active until the condition that activated them is restored. Resetting the control panel is required to restore the heat type event. Resetting the control panel is not required for CO supervisory nonlatching. [1]</p>
Heat detectors (HD)	
Heat alarm	<p>For heat detectors. All activations are immediately considered as alarms. Detectors cannot be restored until the condition causing the activation clears and the panel is reset. [1]</p>
Heat alarm RoR	<p>For heat detectors with rate-of-rise. All activations are immediately considered as alarms. Detectors cannot be restored until the condition causing the activation clears and the panel is reset. [1]</p>
Photoelectric smoke and CO detectors (PCD)	
Smoke Alarm + CO alarm	<p>For smoke + CO detectors that trigger an active alarm event (smoke or CO).</p> <p>Detectors with this device type remain active until the condition that activated them is restored and the control panel is reset.</p>
Smoke alarm + CO monitor latching	<p>For smoke + CO detectors that trigger an active alarm event (smoke) or a CO latching monitor event.</p> <p>Detectors with this device type remain active until the condition that activated them is restored and the control panel is reset.</p>
Smoke alarm + CO monitor nonlatching	<p>For smoke + CO detectors that trigger an active alarm event (smoke) or a CO nonlatching monitor event.</p> <p>Detectors with this device type remain active until the condition that activated them is restored. Resetting the control panel is required to restore the smoke type event. Resetting the control panel is not required for monitor nonlatching.</p>

Device type	Description
Smoke alarm + CO supervisory latching	<p>For smoke + CO detectors that trigger an active alarm event (smoke) or a CO latching supervisory event.</p> <p>Detectors with this device type remain active until the condition that activated them is restored and the control panel is reset.</p>
Smoke alarm + CO supervisory nonlatching	<p>For smoke + CO detectors that trigger an active alarm event (smoke) or a CO nonlatching supervisory event.</p> <p>Detectors with this device type remain active until the condition that activated them is restored. Resetting the control panel is required to restore the smoke type event. Resetting the control panel is not required for supervisory nonlatching.</p>
Smoke supervisory latching + CO alarm	<p>For smoke + CO detectors that trigger a supervisory latching event (smoke) or an active alarm event (CO).</p> <p>Detectors with this device type remain active until the condition that activated them is restored and the panel is reset.</p>
Smoke supervisory latching + CO supervisory latching	<p>For smoke + CO detectors that trigger a supervisory latching event (smoke or CO).</p> <p>Detectors with this device type remain active until the condition that activated them is restored and the panel is reset.</p>
Smoke supervisory latching + CO supervisory nonlatching	<p>For smoke + CO detectors that trigger a supervisory latching event (smoke) or a supervisory nonlatching event (CO).</p> <p>Detectors with this device type remain active until the condition that activated them is restored. Resetting the control panel is required to restore the smoke type event. Resetting the control panel is not required for supervisory nonlatching.</p>
Smoke supervisory latching + CO monitor latching	<p>For smoke + CO detectors that trigger a supervisory latching event (smoke) or monitor latching event (CO).</p> <p>Detectors with this device type remain active until the condition that activated them is restored and the panel is reset.</p>
Smoke supervisory latching + CO monitor nonlatching	<p>For smoke + CO detectors that trigger a supervisory latching event (smoke) or a monitor nonlatching event (CO).</p> <p>Detectors with this device type remain active until the condition that activated them is restored. Resetting the control panel is required to restore the smoke type event. Resetting the control panel is not required for monitor nonlatching.</p>
Smoke supervisory nonlatching + CO alarm	<p>For smoke + CO detectors that trigger a supervisory nonlatching event (smoke) or an active alarm event (CO).</p> <p>Detectors with this device type remain active until the condition that activated them is restored. Resetting the control panel is required to restore the CO type event. Resetting the control panel is not required for supervisory nonlatching.</p>
Smoke supervisory nonlatching + CO supervisory latching	<p>For smoke + CO detectors that trigger a supervisory nonlatching event (smoke) or a supervisory latching event (CO).</p> <p>Detectors with this device type remain active until the condition that activated them is restored. Resetting the control panel is required to restore the CO type event. Resetting the control panel is not required for supervisory nonlatching.</p>

Device type	Description
Smoke supervisory nonlatching + CO supervisory nonlatching	<p>For smoke + CO detectors that trigger a supervisory nonlatching event (smoke or CO).</p> <p>Detectors with this device type remain active until the condition that activated them is restored. Resetting the control panel is not required for supervisory nonlatching.</p>
Smoke supervisory nonlatching + CO monitor latching	<p>For smoke + CO detectors that trigger a supervisory nonlatching event (smoke) or a monitor latching event (CO).</p> <p>Detectors with this device type remain active until the condition that activated them is restored. Resetting the control panel is required to restore the CO type event. Resetting the control panel is not required for supervisory nonlatching.</p>
Smoke supervisory nonlatching + CO monitor nonlatching	<p>For smoke + CO detectors that trigger a supervisory nonlatching event (smoke) or a monitor nonlatching event (CO).</p> <p>Detectors with this device type remain active until the condition that activated them is restored. Resetting the control panel is not required for monitor nonlatching.</p>
Smoke verified + CO alarm	<p>For smoke + CO detectors that trigger an alarm verify event first, and then trigger an active alarm event only after confirming the alarm condition (smoke) or trigger an active alarm event (CO).</p>
Smoke verified + CO supervisory latching	<p>For smoke + CO detectors that trigger an alarm verify event first, and then trigger an active alarm event only after confirming the alarm condition (smoke) or trigger a supervisory latching event (CO).</p>
Smoke verified + CO supervisory nonlatching	<p>For smoke + CO detectors that trigger an alarm verify event first, and then trigger an active alarm event only after confirming the alarm condition (smoke) or trigger a supervisory nonlatching event (CO).</p>
Smoke verified + CO monitor latching	<p>For smoke + CO detectors that trigger an alarm verify event first, and then trigger an active alarm event only after confirming the alarm condition (smoke) or trigger a monitor latching event (CO).</p>
Smoke verified + CO monitor nonlatching	<p>For smoke + CO detectors that trigger an alarm verify event first, and then trigger an active alarm event only after confirming the alarm condition (smoke) or trigger a monitor nonlatching event (CO).</p>
Photoelectric smoke detectors (PD)	
Smoke	<p>For smoke detectors and contact devices. All activations are immediately considered as alarms. The panel and detector cannot be restored to normal until the smoke condition has cleared and the control panel is reset.</p>
Smoke verified	<p>For smoke detectors and contact devices. Two-wire smoke detector activations are verified (delayed and confirmed) before activating an alarm. Four-wire smoke detectors and contact devices are not verified and immediately considered as alarms. The panel and detector cannot be restored to normal until the smoke condition has cleared and the panel is reset.</p>
Supervisory latching	<p>For detectors that trigger an active (supervisory) event. Detectors with this device type remain active until the condition that activated them is restored and the control panel is reset.</p>
Supervisory nonlatching	<p>For detectors that trigger an active (supervisory) event. Detectors with this device type remain active until the smoke condition has cleared. Resetting the control panel is not required.</p>

Device type	Description
Photoelectric smoke/heat and CO detectors (PHCD)	
Smoke/Heat + CO alarm	For heat and smoke + CO detectors that trigger an active alarm event. Detectors with this device type remain active until the condition that activated them is restored and the control panel is reset. [1]
Smoke/Heat + CO monitor latching	For heat and smoke + CO detectors that trigger an active alarm event (smoke or heat) or a CO latching monitor event. Detectors with this device type remain active until the condition that activated them is restored and the control panel is reset. [1]
Smoke/Heat + CO monitor nonlatching	For heat and smoke + CO detectors that trigger an active alarm event (smoke or heat) or a CO nonlatching monitor event. Detectors with this device type remain active until the condition that activated them is restored. Resetting the control panel is required to restore the smoke/heat type event. Resetting the control panel is not required for monitor nonlatching. [1]
Smoke/Heat + CO supervisory latching	For heat and smoke + CO detectors that trigger an active alarm event (smoke or heat) or a CO latching supervisory event. Detectors with this device type remain active until the condition that activated them is restored and the control panel is reset. [1]
Smoke/Heat + CO supervisory nonlatching	For heat and smoke + CO detectors that trigger an active alarm event (smoke or heat) or a CO nonlatching supervisory event. Detectors with this device type remain active until the condition that activated them is restored. Resetting the control panel is required to restore the smoke/heat type event. Resetting the control panel is not required for supervisory nonlatching. [1]
Smoke verified + CO alarm	For smoke + CO detectors that trigger an alarm verify event first, and then trigger an active alarm event only after confirming the alarm condition (smoke) or trigger an active alarm event (CO). [1]
Smoke verified + CO supervisory latching	For smoke + CO detectors that trigger an alarm verify event first, and then trigger an active alarm event only after confirming the alarm condition (smoke) or trigger a supervisory latching event (CO). [1]
Smoke verified + CO supervisory nonlatching	For smoke + CO detectors that trigger an alarm verify event first, and then trigger an active alarm event only after confirming the alarm condition (smoke) or trigger a supervisory nonlatching event (CO). [1]
Smoke verified + CO monitor latching	For smoke + CO detectors that trigger an alarm verify event first, and then trigger an active alarm event only after confirming the alarm condition (smoke) or trigger a monitor latching event (CO). [1]
Smoke verified + CO monitor nonlatching	For smoke + CO detectors that trigger an alarm verify event first, and then trigger an active alarm event only after confirming the alarm condition (smoke) or trigger a monitor nonlatching event (CO). [1]

[1] Supports Standalone mode of operation.

Note: Available device types depend on the position of the slide switch on the front of the module. For example, if the slide switch is in the alarm position, only alarm device types are available.

Table 14: Input module device types

Device type	Description
2Wire Class A	Allows for the monitoring of two-wire conventional smoke detectors in a Class A circuit (that do not require alarm verification) and normally open contact initiating devices on the same circuit. [1]
2Wire Class B	Allows for the monitoring of two-wire conventional smoke detectors in a Class B circuit (that do not require alarm verification) and normally open contact initiating devices on the same circuit. [1]
2Wire verify Class A	Allows for the monitoring of two-wire conventional smoke detectors in a Class A circuit (that require alarm verification). [1]
2Wire verify Class B	Allows for the monitoring of two-wire conventional smoke detectors in a Class B circuit (that require alarm verification). [1]
Alarm	For smoke detectors and contact devices. All activations are immediately considered as alarms. Circuit cannot be restored until devices are restored to normal and the panel is reset. [1]
Duct alarm	For duct smoke detectors. All activations are immediately considered as alarms. Circuit cannot be restored until devices are restored to normal and the panel is reset. [1]
Heat	For heat detectors and contact devices. All activations are immediately considered as alarms. Circuit cannot be restored until devices are restored to normal and the panel is reset. [1]
Pull station	For pull station devices. All activations are immediately considered as alarms. [1]
Remote drill	For a remote switch that when activated, starts the panel's drill operation.
Remote reset	For a remote switch that when activated, resets the panel.
Remote signal silence	For a remote switch that when activated, silences the signaling devices. Two-wire smoke detector activations are verified (delayed and confirmed) before activating an alarm. Four-wire smoke detectors and contact devices are not verified and are considered alarm immediately.
Waterflow	For connecting vane type and pressure flow switches. Activations are considered as alarms. A 16-second alarm delay applies to waterflow activations. Circuit cannot be restored until devices are restored to normal and the panel is reset. Waterflow activations do not invoke in-suite signal silence. [1]
Waterflow No Delay	For connecting vane type and pressure flow switches. Activations are considered as alarms. No alarm delay applies to waterflow activations for this device type. Circuit cannot be restored until devices are restored to normal and the panel is reset. Waterflow activations do not invoke in suite signal silence. [1]
Waterflow No Delay Class A	For connecting vane type and pressure flow switches in a Class A circuit. Activations are considered as alarms. No alarm delay applies to waterflow activations for this device type. Circuit cannot be restored until devices are restored to normal and the panel is reset. Waterflow activations do not invoke in suite signal silence. [1]

[1] Supports Standalone mode of operation.

Table 15: Supervisory device types

Device types	Description
Duct supervisory (latching and nonlatching)	For duct supervisory devices. Momentary activation of normally open devices immediately places the panel in a supervisory state and turns on supervisory LEDs and relays. Circuit cannot be restored until devices are restored to normal and the panel is reset. Resetting the panel is not required for nonlatching.
Supervisory latching	For supervisory devices. Momentary activation of normally open devices immediately places the panel in a supervisory state and turns on supervisory LEDs and relays. Circuit cannot be restored until devices are restored to normal and the panel is reset.
Supervisory nonlatching	For supervisory devices. Momentary activation of normally open devices immediately places the panel in a supervisory state and turns on the supervisory LED and relay. Annunciation remains active until the input restores. The panel does not have to be reset.

Table 16: Trouble device types

Device type	Description
Remote AC fail	For use with auxiliary power supplies to provide AC Fail indication to the fire panel. The fire panel treats this activation as if the panel itself detected an AC fail condition. Delays off-premises signaling for the selected time duration.

Table 17: Monitor device types

Device type	Description
Monitor	Monitoring of normally open switches for other functions (fire door position, etc.). Not approved for use under CAN/ULC-S527 in Canada.

Table 18: Output device types

Device type	Description
Continuous nonsilenceable	For nonsilenceable strobes and notification appliances that generate a temporal pattern. [2]
Continuous nonsilenceable (latched)	For latching strobes and notification appliances that generate a temporal pattern.
Continuous silenceable	For strobes and notification appliances that generate a noncoded tone.
Genesis audible visible silence	For Genesis and Enhanced Integrity horns and strobes. Genesis and Enhanced Integrity appliances maintain synchronization per UL 1971. For Genesis devices only, connected horns can be silenced and strobes turn off.
Genesis nonsilenceable	For Genesis and Enhanced Integrity horns and strobes. Genesis and Enhanced Integrity appliances maintain synchronization per UL 1971. For Genesis devices only, connected horns cannot be silenced and strobes on the same two-wire circuit flash until the panel is reset. [2]
Relay nonsilenceable	For relay devices that do not follow signal silence [2]
Relay nonsilenceable (latched)	For relay devices that do not follow signal silence and do not restore until manually unlatched

Device type	Description
Relay silence	For relays that turn off when you press Signal Silence. [2]
Supervised output	For modules that output an unsynchronized signal and that do not turn off when you press Signal Silence.
Supervised output (latched)	For latched output modules that output an unsynchronized signal and that do not turn off when you press Signal Silence.
Auto sync output Silenceable	For generating sound patterns on sounder bases for carbon monoxide (CO) and fire signals. Signals turn off when you press Signal Silence. Only patterns from T3T4 are silenced.
Auto sync output nonsilenceable	For generating sound patterns on sounder bases for carbon monoxide (CO) and fire signals.
Unlatch outputs	For output modules that are configured to manually unlatch latched outputs [1]

[1] The following input modules can be configured to unlatch latched outputs: FX-IDC1A, FX-IDC1B, FX-IDC2B, or RZI16-2RS.

[2] Supports Standalone mode of operation.

Table 19: NAC modules

Device type	Description
Genesis-audible/visible silence	For Genesis and Enhanced Integrity horns and strobes. Genesis and Enhanced Integrity appliances maintain synchronization per UL 1971. For Genesis devices only, connected horns can be silenced and strobes turn off. [1]
Genesis-non-silence	For Genesis and Enhanced Integrity horns and strobes. Genesis and Enhanced Integrity appliances maintain synchronization per UL 1971. For Genesis devices only, connected horns cannot be silenced and strobes on the same two-wire circuit flash until the panel is reset. [1]
Genesis-audible silence	For Genesis and Enhanced Integrity horns and strobes. Genesis and Enhanced Integrity appliances maintain synchronization per UL 1971. For Genesis devices only, it allows connected horns to be silenced while strobes on the same two-wire circuit continue to flash until panel reset. [1]
Continuous silenceable	For strobes and notification appliances that self-generate a temporal pattern [1]
Continuous non-silenceable	For strobes and notification appliances that self-generate a temporal pattern [1]
Supervised	Lets you connect supervisory devices, such as a relay device or switch
City tie	Outputs an unsynchronized, 24-volt continuous (steady) signal that cannot be silenced or disabled. Select this NAC type when the NAC is connected to a city tie module.

[1] Supports Standalone mode of operation.

Table 20: Latched output device types [1]

Device type	Description
Continuous nonsilenceable (latched)	For Class B latched output modules that output an unsynchronized signal. Does not follow signal silence.
Relay nonsilence NC (latched)	For relay devices functioning as latched output devices that open when activated. Does not follow signal silence.

Device type	Description
Relay nonsilence NO (latched) latch	For relay devices functioning as latched output devices that close when activated. Does not follow signal silence.
Relay nonsilenceable (latched)	For Class B relay devices functioning as latched output devices. Does not follow signal silence.
Supervised output (latched)	For Class B latched output modules that output an unsynchronized signal. Does not follow signal silence.
Supervised outputs Class A (latched)	For Class A latched output modules that output an unsynchronized signal. Does not follow Signal Silence.

[1] Table 30 on page 96 gives a full list of devices configurable as latched output devices.

Displaying the Program menu

Use the Program menu to access the options that let you program your panel.

To display the program menu:

1. Press the Menu button.
2. Choose Program.
3. Press Enter.

Setting the time and date

The first step in programming the panel is setting the time and date. You must do this before using either the Auto Program or Advanced Program command.

To set the time and date:

1. Press the Menu button and choose Program.
2. Choose Date and Time.
3. Enter a level one password.
4. Enter the current date.
5. Enter the current time.
6. Choose Save.
7. Press the Menu button to exit menu mode.

— or —

Continue programming

Setting daylight saving time

Daylight saving time options allow the panel to switch automatically from standard to daylight saving time and vice versa.

To program daylight saving time options:

1. Display the Program menu and choose Date and Time.
2. Enter a level one password.
3. Choose Daylight Savings.
4. Choose one of the following:
 - Yes: The panel recognizes daylight saving time
 - No: The panel does not recognize daylight saving time
5. Set the Month Start. (Values range from 01 to 12, where 01 corresponds to January.)
6. Set the Month End. (Values range from 01 to 12.)
7. Set the Week Start. (Values range from 1 to 5, where 5 corresponds to the last week of the month.)
8. Set the Week End. (Values range from 1 to 5, where 5 corresponds to the last week of the month.)
9. Set the Weekday Start. (Values range from 1 to 7, where 1 corresponds to Sunday.)
10. Set the Weekday End.
11. Set the Hour Start. (Values range from 00 to 23, where 00 corresponds to 12 midnight.)
12. Set the Hour End. (Values range from 00 to 23.)
13. Set the Minutes Offset. (Values range from 0 to 255.). This controls the number of minutes the clock will adjust when daylight saving time begins and ends. The default is 60 minutes.
14. Press Enter, and then choose Save.
15. Press the Menu button to exit menu mode, or continue programming.

Sample values for daylight saving time

The values in the following table:

- Start daylight saving time at 2:00 a.m. on Sunday, the second week of March
- Return to standard time at 2:00 a.m. on Sunday, the first week in November
- Adjust the time by 60 minutes (1 hour) each time

Table 21: Sample values for daylight saving time

Month start:	March
Week start:	Second
Week day start:	Sunday
Hour start:	2
Month end:	November
Week end:	First
Week day end:	Sunday
Hour end:	2
Adjustment minutes:	60

Changing the passwords

The second step in programming the panel is to change the level one, level two, and remote annunciator passwords.

Notes

- We recommend that you change the default passwords before programming the system.
- The system automatically logs you off after four minutes of inactivity.

To change the passwords:

1. Press the Menu button and choose Program.
2. Choose Password.
3. Enter a level two password.
4. Select the password to be changed: Level 1, Level 2, or Remote (Ann.).
5. Enter the old password and press Enter.
6. Enter the new password and press Enter.
7. Repeat steps 4 through 6 for each password to be changed.
8. Press the Menu button to exit menu mode, or continue programming.

Restoring the factory default settings

Use the Restore Defaults command to overwrite most custom settings in the panel, the dialer (CMS network), or both. This lets you commission the panel as a common alarm system, or remove custom settings in preparation for advanced programming.

Note: The current language, marketplace, and loop device configuration settings are *not* affected by the Restore Defaults command.

To restore the default settings:

1. Press the Menu button and choose Program.
2. Choose Restore Defaults.
3. Enter a level two password.
4. Select either Panel Only, CMS Only, or Panel and CMS.

Panel only: Restores only the panel's defaults (panel operation and panel configuration options)

CMS only: Restores only the dialer, network (1-8)

Panel and CMS: Restores both the panel and CMS device defaults

5. Press Enter.
6. Return to the Program menu.
7. Choose Panel Restart.
8. Choose Yes.

The panel restarts, and the factory default settings are reloaded into the database.

Setting up the programmable keys

There are two control panel buttons that can be assigned to correlation groups in order to:

- Disable a correlation group or members of a correlation group
- Activate and restore the outputs in a correlation group
- Unlatch all latched output devices globally

Notes

- You should not disable the SIGA-REL device when it is part of a correlation group.
- You should not configure user keys as correlation group input devices.

By default, the buttons are not programmed. The buttons can be labeled to indicate their function with a slip-in label. To operate the buttons, you must be logged on with a level one password or greater.

Figure 47: Programmable keys

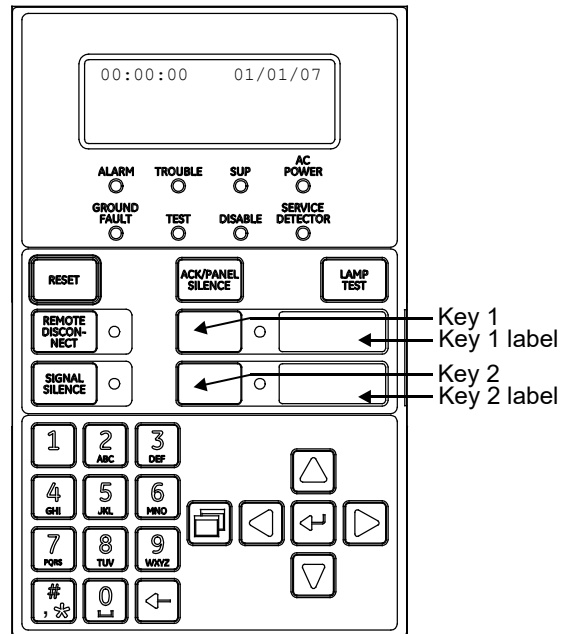

Note: You cannot program a key while it is active. When the “Key is active” message is displayed, wait until the key deactivates before continuing.

Table 22: Programmable key functions

Function	Option	Behavior when user key is pressed
None		User key does not respond.
Activate		Activates the outputs that belong to the correlation groups associated with the user key.
Disable	Members	Disables all of the inputs and outputs, including NACs, and zones that belong to the correlation groups associated with the user key with an option of “Members.”
Disable	CorrGrp	Disables the correlation groups associated with the user key with an option of “Group.” The devices, NACs, and zones that belong to the correlation group remain enabled. Disabled correlation groups do not activate even if the required number of inputs activate. This is typically used to prevent relay and sounder bases from sounding.
Disable	Both	Disables all of the devices, NACs, and zones that belong to the correlation groups associated with the user key with an option of “Members + Group.” It also disables the correlation group.
Restore		Restores the outputs that belong to the correlation groups associated with the user key only if it is active.
Unlatch		Unlatches all latched outputs in the system.

Function	Option	Behavior when user key is pressed
Alarm ON		<p>Used for manual evacuation in the Canadian marketplace. Pressing the Alarm ON button places the control panel in the alarm condition, activates all drillable outputs which include all notification appliance circuits and all sounder bases, signals the central station with CID 115. The panel still responds to initiating device circuits that are activated while sounding a manual evacuation. The Alarm ON event is restored upon panel reset. If Alarm ON is initiated while reset is in progress, the event will be restored at the end of reset.</p> <p>To meet CAN/ULC-S527 requirements, User Key 1 default is Alarm ON when the Canadian marketplace is selected.</p>

To set up a programmable key:

1. Press the Menu button and choose Program.
2. Choose Programmable Keys.
3. Enter a level two password.
4. Choose the key to be programmed.
5. Choose Edit List or New List. Both commands let you select a function and edit the list of correlation groups assigned to the key. The difference between the two is that:
 - Edit List lets you make changes to a key that has already been programmed. Choose this command to change the key's function, or edit the list of correlation groups assigned to it.

Note: If you select Edit List for a key that has not yet been programmed, the message "Nothing to Edit" is displayed. Choose New List instead.

 - New List can be used to set up a new programmable key or to overwrite the current programming of a key that has already been set up.
6. Choose a function to assign to the key.
 - None
 - Activate
 - Disable
 - Unlatch
 - Restore
 - Alarm ON

Note: To disable a programmed key, choose None.

7. If you chose Unlatch in step 6:
 - Press Enter to reopen the previous menu, and then choose Save.

— or —

Press the Menu button to exit menu mode without saving.

The button is now completely programmed to unlatch all latched outputs globally.

8. If you chose Disable, press the down arrow to edit the Control option, and indicate what the key should control. Choose:
 - Members
 - CorrGrp
 - Both

Press Enter to reopen the previous menu, and then choose Save.

Note: This option is not available for Unlatch, Activate, or Restore.

You are now ready to choose the correlation groups to be activated, disabled, or restored.

9. Enter the number of the first correlation group to be assigned or unassigned, and then press Enter.
 - If you enter the number of a correlation group that is already assigned to the key, the command REM (remove) is displayed. Pressing Enter removes the group from the list.
 - If you enter the number of a correlation group that has not yet been assigned to the key, the command ADD is displayed. Pressing Enter adds the new group to the list.
10. Enter the number of the next correlation group to be added or removed, and then press Enter. Repeat to add or remove any remaining correlation groups.
11. When you have finished editing the list of correlation groups, press Enter to reopen the previous menu, and then choose Save.

— or —

Press the Menu button to cancel your changes and exit menu mode.

12. Press the Menu button to exit menu mode. The button is now programmed to activate, disable, or restore all correlation groups that you have added to the list.

Clearing the event history log

The panel maintains a log of the most recent 999 system or user events. The event record contains the event time, the event type, the event state, and the event ID. The event time is the time and date of the event activation or restoration. All of these records are stored in the panel's history database and can be cleared (deleted) if needed. Once the history log exceeds 999 events, the oldest event is deleted as the newest event is added.

Once the history log is cleared, all new panel events are stored in history. You might want to clear the history log in the following situations:

- When installation is complete, you can clear the history log before turning the system over to the building owner.
- If the system history log is filled with event records resulting from a faulty device, problem, or situation, you can clear the history log after the problem is addressed.

Note: When the history log is full, the oldest event is deleted when a new event is added.

To clear the event history log:

1. Press the Menu button and choose Program.
2. Choose Clear History.
3. Enter a level two password.
4. Select Yes to clear history or No to leave history unchanged.
5. Press Enter.
6. Press the Menu button to exit menu mode, or continue programming.

Updating the firmware

The Firmware Update Utility (FUU) lets you install new firmware in the main panel or loop interface module. It also lets you retrieve the current firmware version in your panel. Refer to the Firmware Update Utility release notes to verify which panel versions can be updated using the FUU. Refer to the FUU help for instructions on how to use the FUU.

Updating the loop interface module firmware is a three-step process.

1. Obtain the loop interface module firmware from the appropriate website, and then load it into the FUU software.
2. Download the loop interface module firmware to the panel main board using the FUU software.
3. Write the loop interface module firmware from the panel main board to the SLC card using front panel programming.

Restarting the panel

The Panel Restart command restarts (reboots) the panel without having to cycle AC power.

To restart the panel:

1. Press the menu button and choose Program.
2. Choose Panel Restart.
3. Enter your level two password.
4. Choose Yes to restart the panel.

— or —

Choose No to cancel.

Enabling RS-232 communication

The RS232 CU Enable command lets you connect a PC to the control panel by means of the optional RS-232 card or SA-USB card. This enables you to use the Configuration Utility (CU) to program the panel and upload or download panel data.

Notes

- The RS232 CU Enable command times out (turns off) after four minutes of inactivity, meaning that if communication is enabled but the panel does not connect to the CU PC within four minutes, communication is automatically disabled.
- The SA-USB card requires installation of a driver the first time it is connected to the computer to enable communication. Refer to the *SA-USB Interface Card Installation Sheet*, (P/N 3102654) for details.

To enable RS-232 communication:

1. Set the Printer/FSB property “type” to None/FSCU in panel. Press the Menu button and choose Program > Advanced Program >Panel Configuration >Printer/FSB.
2. Disconnect the printer cable from the RS-232 card or SA-USB card.
3. Connect the configuration utility computer to the RS-232 card or SA-USB card.
4. Press the Menu button and choose Program.
5. Choose RS232 CU Enable.
The RS232 CU Enable screen is displayed.
6. Choose On.
The panel can now communicate with the CU.
7. When you have finished, disconnect the PC from the RS-232 card or SA-USB card.
8. Turn off RS232 CU Enable.
9. Reconnect the printer cable to the RS-232 card or SA-USB card if needed.

Auto programming the panel

Auto programming detects and applies default settings to installed devices, NACs, remote annunciators, and expansion cards. You can control many aspects of the process by programming the options listed in:

- “Auto programming options” on page 70
- “Dialer options” on page 73

Auto programming sets up a common alarm system. After the auto programming process has finished, you can continue with advanced programming to apply any custom settings that may be required.

Caution: Auto programming replaces the current settings for devices, NACs, remote annunciators, and expansion cards with default settings.

Notes

- Before starting the auto programming sequence, set the time and date and change the default passwords. See “Factory default settings” on page 43. for a list of all the settings that will be applied during auto programming.
- Auto programming places most input devices (alarm device type) and NACs in correlation group 001. Relay and sounder bases are not automatically assigned to correlation groups. For more information on correlation groups, see “What is a correlation group?” on page 39 and “Correlation group programming” on page 85.
- Auto programming turns off the In Suite Signal Silence option for all correlation groups.
- If you choose to label devices during auto programming, devices are labeled by entering the address of the device and then entering the label for the device. It is important for you to have the Device Settings worksheet filled out for each device so that you can easily select a device ID and label it correctly.

Auto programming options

Table 23 below describes the options to be set when auto programming the panel.

Table 23: Auto programming options [1]

Option	Description
Auto zoning	<p>This option controls whether devices are automatically assigned to zones. The number of devices assigned to a zone is based on the type of panel:</p> <ul style="list-style-type: none"> • FX-64 panel: Four devices per zone • FX-1000 panel: Sixteen devices per zone <p>Yes: The system automatically finds all of the devices connected to the system and assigns them to a zone. Only the primary element of dual element detectors are assigned to a zone. See Zone configuration for details.</p> <p>No: The system automatically finds all of the devices connected to the system and does not assign them to a zone.</p>

Option	Description
Dialer	<p>Configures the panel to communicate with the CMS via a dialer. The dialer is configured as a dual line so that all messages are sent to two separate receivers with different phone numbers and account codes.</p> <p>Note: Not all dialer programming options are acceptable for UL/ULC installations. See “UL/ULC programming requirements” on page 37 for details.</p> <p>Yes: Enables the dialer and configures it for dual-line communication with the CMS. All messages will be sent to two separate receivers that have different phone numbers and account codes.</p> <p>No: Dialer is not enabled.</p>
Event notification	<p>Configures event reporting for zones, individual devices, or both.</p> <p>Zone: When a device is a member of a zone, only the zone information is sent to the LCD, LEDs, printer, and dialer. Device level reporting configuration is not available.</p> <p>Zone/device: Zone information is sent to the LCD and LEDs. Device information is sent to the printer and dialer. Zone/device reporting locations can be configured through custom programming.</p> <p>Device: Only device information is reported, no zone information</p>
Label devices	<p>Configures the auto programming sequence to allow you to label devices using the alphanumeric keypad.</p> <p>Yes: Enables device labeling</p> <p>No: Disables device labeling</p>
Label zones	<p>Configures the auto programming sequence to allow you to label zones using the alphanumeric keypad.</p> <p>Yes: Enables zone labeling</p> <p>No: Disables zone labeling</p>

Option	Description
Follow	<p>This option controls the conditions that will activate relay or sounder detector bases. Select from the following values.</p> <p>Head: The base is controlled by the detector's settings.</p> <ul style="list-style-type: none"> • The base activates when the detector goes into alarm, unless the detector is set for alarm verification. • If the detector is set for alarm verification, the base activates when the detector goes into alarm verification. It does not restore, however, until the alarm restores. • The base does not respond when the detector goes into prealarm no matter how the detector is configured. Also, the base only follows the primary element of a dual element detector. Any activation from a secondary element does not trigger the base. <p>Example: When using a PCD (Smoke/CO) detector and assigning it the Follow "Head" option, the activation of the photoelectric element will cause the local sounder/relay base to activate automatically. However, if the CO element portion of the device activates without the activation of the photoelectric element, the sounder/relay base will not activate.</p> <ul style="list-style-type: none"> • Devices with the base set to follow Head cannot be placed in correlation groups. When a device base is set to follow Head, the base is removed as an output from any correlation groups to which it belongs. <p>Alarm: The base activates its relay when the detector goes into alarm. The base will not restore until the alarm event has been restored. Any activation from a secondary element (Active3) does not trigger the base. For CO device operation, see Follow CO below.</p> <p>Alarm and verify (ALM+VFY): The base activates its relay when the detector goes into alarm verify and continues when the detector goes into alarm. The base will not restore until both events have been restored.</p> <p>Alarm and prealarm (ALM+PALM): The base activates its relay when the detector goes into prealarm and continues when the detector goes into an alarm. The base will not restore until both events have been restored.</p> <p>Riser: The base is triggered individually by the loop controller (sounder bases only).</p> <p>None: A correlation group triggers the base. It can be applied to both relay and sounder bases and is used for relay bases configured as latched output devices.</p> <p>Note: All base follow settings except Head and Riser can be activated by correlation groups.</p>
Follow CO	<p>This option controls the conditions that will activate relay or sounder detector bases. Select Yes to allow the device's secondary element (example CO) to activate the base programmed functions.</p> <p>Note: This option is not available for Base Follow types of Head, Riser, or None.</p>

[1] Not all options listed here are displayed on all systems.

Dialer options

Table 24 describes the options used to set up the dialer.

Table 24: Auto programming — Dialer options [1]

Option	Description
Account 1	<p>Account ID: Enter the four-digit ID code for account 1. (Note, if you do not change the default of FFFF, no events will be sent.)</p> <p>Primary receiver number: Enter the primary receiver's phone number. Up to 20 digits (0-9, *, #, and ,). The comma causes a two-second delay in dialing. The number or hash symbol (#) and the asterisk symbol (*) are used with calling feature codes and services. Consult your telephone service provider.</p> <p>Secondary receiver number: Enter the secondary receiver's phone number. Up to 20 digits (0-9, *, #, and ,). The comma causes a two-second delay in dialing.</p> <p>Format: CID</p> <p>CID: Contact ID is the alarm format that the monitoring facility (DACR) will receive. See "Default contact ID event codes" on page 49.</p> <p>Event notification: Set event notification (event reporting) to:</p> <p>Device: Only device information is reported or transmitted, no zone information. This setting uses default device event notification settings for reporting events. See "Factory default settings" on page 43.</p> <p>Zone: When a device is a member of a zone, only the zone information is reported or transmitted, no device information. This setting uses default zone event notification settings for reporting events. See "Factory default settings" on page 43.</p> <p>Event: Only the event type (alarm, supervisory, trouble, etc.) is reported or transmitted, no device or zone information. This setting uses the default CMS event notification settings for reporting events. See "Factory default settings" on page 43.</p>
Account 2	<p>Account ID: Enter four-digit ID code for account 2.</p> <p>Primary receiver number: Enter the primary receiver's phone number (up to 20 digits).</p> <p>Secondary receiver number: Enter the secondary receiver's phone number (up to 20 digits).</p> <p>Format: CID</p> <p>CID: Contact ID is the alarm format that the monitoring facility (DACR) will receive. See "Default contact ID event codes" on page 49.</p> <p>Event notification: Set event notification (event reporting) to:</p> <p>Device: Only device information is reported or transmitted, no zone information. This setting uses default device event notification settings for reporting events. See "Factory default settings" on page 43.</p> <p>Zone: When a device is a member of a zone, only the zone information is reported or transmitted, no device information. This setting uses default zone event notification settings for reporting events. See "Factory default settings" on page 43.</p> <p>Event: Only the event type (alarm, supervisory, trouble, etc.) is reported or transmitted, no device or zone information. This setting uses the default CMS event notification settings for reporting events. See "Factory default settings" on page 43.</p>

[1] Dialer options are displayed only if a dialer is installed on the panel.

Auto programming procedure

Use the following procedure to auto program the panel, referring to the options listed in Table 23 on page 70. Not all options shown are displayed on all systems.

To auto program a panel:

1. Press the menu button and choose Program.
2. Choose Auto Program.
3. Enter a level two password.
4. When the “Current config. will be lost!” message displays on the LCD:

Select Continue to continue with auto programming

— or —

Select Cancel to return to the programming menu.

5. Set auto programming options.

Note: Use the right or left arrow button rather than the Enter button to select values for each option. The Enter button begins the auto programming operation no matter which option the cursor is on. Also, the options you select are preserved and will be displayed the next time you auto program.

6. When you have finished, press Enter.

The panel begins auto programming and displays the number of devices on the system. If you have more than one loop, the device counts are per loop. If you previously programmed the panel, The system displays the number of old and new devices.

7. Press Enter to continue.

Auto programming continues based on the settings you made above.

8. When prompted, program the options you selected using the procedures that follow. For example, if you are using a dialer, auto programming requires you to program specific dialer options.

9. When auto programming is complete, the system displays the banner screen.

Labeling devices

If you set the Label Devices auto programming option to Yes, follow these steps to label the devices.

To label devices:

1. Next to “Device,” enter the device number to be labeled.
2. Enter a text label for the device (two lines of 20 characters). The default label is “Loop X Device XXX.”
3. Press Enter to save the label and go to the next number of the device.
Note: Pressing the Enter button saves the current label, and then goes to the next available device, so that you can quickly go to each device and label it.
4. Enter a text label for the device (two lines of 20 characters).
5. Repeat steps 3 and 4 until all devices are labeled.
6. When you have finished labeling, place the cursor in the device number field, and then press the Cancel button to reopen the previous menu. Continue with the next auto programming option.

See “Programming relay and sounder detector bases” on page 95.

Labeling zones

If you set the Label Zones auto programming option to Yes, follow these steps to label zones.

To label zones:

1. Next to “Zone,” enter the number of the zone to be labeled.
2. Enter a text label for the zone (two lines of 20 characters). The default label is “Zone XX.”
3. Press Enter to save the label and go to the next number of the zone.
Note: Pressing the Enter button saves the current label, and then goes to the next zone number so that you can quickly go to each zone and label it.
4. Enter a text label for the zone (two lines of 20 characters).
5. Repeat steps 3 and 4 until all zones are labeled.
6. When you have finished labeling, make sure the cursor is on the zone number, and then press the Cancel button to exit and go to the next auto programming option.

Performing incremental programming

Incremental programming lets you add and label devices and zones to an existing database without affecting current settings. It is typically used to add or remove a device loop or a large number of individual devices. Incremental programming should be used only after the panel has been programmed either by auto programming or advanced programming.

Incremental programming options

Table 26 below describes the options to be set when performing incremental programming.

Table 25: Incremental programming options

Device option	Description
Loop	Select the loop (number) that you want to program, or select All to program all loops.
Label devices	Yes: Enables device labeling No: Disables device labeling
Label zones	Yes: Enables zone labeling No: Disables zone labeling
Follow	<p>This option controls the conditions that will activate relay or sounder detector bases. Select from the following values:</p> <p>Head: The base is controlled by the detector's settings.</p> <ul style="list-style-type: none"> The base activates when the detector goes into alarm, unless the detector is set for alarm verification. If the detector is set for alarm verification, the base activates when the detector goes into alarm verification. It does not restore, however, until the alarm restores. The base does not respond when the detector goes into prealarm no matter how the detector is configured. Also, the base only follows the primary element of a dual element detector. Any activation from a secondary element does not trigger the base. <p>Example: When using a PCD (Smoke/CO) detector and assigning it the Follow "Head" option, the activation of the photoelectric element will cause the local sounder/relay base to activate automatically. However, if the CO element portion of the device activates without the activation of the photoelectric element, the sounder/relay base will not activate.</p> <ul style="list-style-type: none"> Devices with the base set to follow Head cannot be placed in correlation groups. When a device base is set to follow Head, the base is removed as an output from any Correlation Groups to which it belongs. <p>Alarm: The base activates its relay when the detector goes into alarm. The base will not restore until the alarm event has been restored. Any activation from a secondary element (Active3) does not trigger the base. For CO device operation, see Follow CO below.</p> <p>Alarm and verify (ALM+VFY): The base activates its relay when the detector goes into alarm verify and continues when the detector goes into alarm. The base will not restore until both events have been restored.</p>

Device option	Description
	<p>Alarm and prealarm (ALM+PALM): The base activates its relay when the detector goes into prealarm and continues when the detector goes into an alarm. The base will not restore until both events have been restored.</p> <p>Riser: The base is triggered individually by the loop controller (sounder bases only).</p> <p>None: A correlation group triggers the base. It can be applied to both relay and sounder bases and is used for relay bases configured as latched output devices.</p>
Follow CO	<p>This option controls the conditions that will activate relay or sounder detector bases. Select Yes to allow the device's secondary element (example CO) to activate the base programmed functions.</p> <p>Note: This option is not available for base follow types of Head, Riser, or None.</p>

Incremental programming procedure

Referring to Table 26 on page 76, follow these steps to auto program the panel. Not all options shown in Table 26 are displayed on all systems.

Notes

- Use the Right or Left Arrow button rather than the Enter button to select values for each option. The Enter button starts the incremental program sequence immediately no matter which option the cursor is on.
- The values you select are preserved and will be displayed as defaults the next time you incrementally program the panel.

To perform incremental programming:

1. Press the Menu button and choose Program.
2. Choose Incremental Program.
3. Enter a level two password.
4. Set the incremental programming options using Table 26 on page 76.
5. When you have finished, press Enter.

The panel begins incremental programming and displays the number of devices in the system. If the panel has two or more loops, the device counts for each loop are given separately. The system displays the number of old and new devices.

6. Press Enter to continue.

Incremental programming continues based on the settings you made above.

7. If you chose to label devices and/or zones, use the procedures that follow to enter labels.
8. When incremental programming is complete, the system returns you to the banner screen.

Labeling devices

If you set the Label Devices incremental programming option to yes, follow this procedure to label the devices.

To label devices:

1. Next to “Device,” enter the number of the device to be labeled.
2. Enter a text label for the device (two lines of 20 characters). The default label is “Loop X Device XXX.”
3. Press Enter to save the label and go to the next number of the device.

Note: Pressing the Enter button saves the current label and displays the next device number. This lets you move quickly from one device to the next.

4. Repeat steps 2 and 3 until all devices are labeled.
5. When you have finished labeling, place the cursor on the device number, and press the Cancel button to continue with the next incremental programming option.

See “Programming relay and sounder detector bases” on page 95.

Labeling zones

If you set the Label Zones incremental programming option to Yes, follow these steps to label zones.

To label zones:

1. Enter the zone number to be labeled.
2. Enter a text label for the zone (two lines of 20 characters). The default label is “Zone XX.”
3. Press Enter to save the label and go to the next zone number.

Note: Pressing the Enter button saves the current label and then goes to the next zone number so that you can quickly go to each zone and label it.

4. Enter a text label for the zone (two lines of 20 characters).
5. Repeat steps 3 and 4 until all zones are labeled.
6. When you have finished labeling, move the cursor to the zone number, and then press the Cancel button to continue with the next incremental programming option.

Adding and removing devices from programmed systems

You can add an additional device or several devices to a system that has already been programmed without reentering programming mode. Once the device is installed, the panel signals a trouble active event and indicates on the LCD screen that there is an unconfigured device. The device can then be programmed and added to the database.

Notes

- If you are adding more than a few devices, you may want to use the Incremental programming option that lets you quickly add and label the devices. See “Performing incremental programming” on page 76.
- You must log on with a level two password to add a device.

Device programming options

Table 27 below describes the options to be set when programming devices.

Table 26: Device options

Device option	Description
Zone	Select the zone you want to add this device to or select Off if you are not adding the device to a zone.
Label	Enter a text label for the device (two lines of 20 characters). When you have finished, select Save.
Correlation groups	<p>Assigns the device to one or more correlation groups. For more information, see “What is a correlation group?” on page 39.</p> <p>Enter the number of the correlation group to which the device is assigned. Choose Included or Excluded.</p> <ul style="list-style-type: none"> • “Included” adds assigns the item to the group. • “Excluded” removes the item from the group <p>When you have finished, choose Save.</p>
Event notification	<p>Sets the options needed for messages for the active, alarm verify, disable, maintenance, prealarm, test, trouble, and events. See “Factory default settings” on page 43 for device event notification default settings.</p> <p>Printer: Yes or No. This controls whether event information is sent to the printer.</p> <p>Coder: Four-digit coded output that is played in response to alarm conditions (00-00-00-00 to 99-99-99-99).</p> <p>Dialer:</p> <ul style="list-style-type: none"> • Acct 1 & 2: Event information is sent to both dialer accounts • Acct 1: Event information is sent to dialer account one • Acct 2: Event information is sent to dialer account two

Device option	Description
	<ul style="list-style-type: none"> • None: Event information is not sent to the dialer <p>NET (1-8): Yes or No. Controls whether event information is sent to the connected Ethernet receiver.</p> <p>CID: Contact ID event code (000 to 999).</p> <p>When you have finished, choose Save.</p>
Day sensitivity	Sets the daytime smoke level sensitivity. Choose least, less, more, normal, or most.
Night sensitivity	Sets the nighttime smoke level sensitivity. Choose least, less, more, normal, or most.
Day prealarm%	<p>Sets the daytime prealarm percentage. Choose Off or 50, 55, 60, 65, 70, 75, 80, or 90 percent.</p> <p>This sets the amount of smoke that indicates a prealarm event before an actual alarm event is indicated. The percentage is based on the sensitivity level selected above. For example, if you choose normal sensitivity and select 50 percent for your prealarm, when smoke levels reach 50% of the normal smoke level required to initiate an alarm, a prealarm event is indicated.</p>
Night prealarm%	<p>Sets the nighttime prealarm percentage. Choose Off or 50, 55, 60, 65, 70, 75, 80, or 90 percent.</p> <p>This sets the amount of smoke that indicates a prealarm event before an actual alarm event is indicated. The percentage is based on the sensitivity level selected above. For example, if you choose normal sensitivity and select 50 percent for your prealarm, when smoke levels reach 50% of the normal smoke level required to initiate an alarm, a prealarm event is indicated.</p>
Base type	Sets the base type for detectors. Choose standard, relay, isolator, or sounder.
Follow	<p>This option controls the conditions that activate the relay or sounder detector base.</p> <p>Note: All base follow settings except Head and Riser can be activated by correlation groups. Select from the following values.</p> <p>Head: The base is controlled by the detector's settings:</p> <ul style="list-style-type: none"> • The base activates when the detector goes into alarm, unless the detector is set for alarm verification. • If the detector is set for alarm verification, the base activates when the detector goes into alarm verification. It does not restore, however, until the alarm restores. • The base does not respond when the detector goes into prealarm no matter how the detector is configured. Also, the base only follows the primary element of a dual element detector. Any activation from a secondary element does not trigger the base. <p>Example: When a PCD on a sounder base has a follow set to Head, the base is only triggered when a smoke event is generated. The base does not trigger when a CO event is generated.</p> <ul style="list-style-type: none"> • Devices with the base set to follow Head cannot be placed in correlation groups. When a device base is set to follow Head, the base is removed as an output from any correlation groups to which it belongs. <p>Alarm: The base activates its relay when the detector goes into alarm. The base does not restore until the alarm event has been restored. Any activation from a secondary element (Active3) does not trigger the base. For CO device operation, see Follow CO below.</p>

Device option	Description
	Alarm and verify (ALM+VFY): The base activates its relay when the detector goes into alarm verify and continues when the detector goes into alarm. The base does not restore until both events have been restored.
	Alarm and prealarm (ALM+PALM): The base activates its relay when the detector goes into prealarm and continues when the detector goes into an alarm. The base does not restore until both events have been restored.
	Riser: The base is triggered individually by the loop controller (sounder bases only).
	None: A correlation group triggers the base. This can be applied to both relay and sounder bases and is used for relay bases configured as latched output devices.
Follow CO	This option controls the conditions that will activate relay or sounder detector bases. Select Yes to allow the device's secondary element (example CO) to activate the base programmed functions. Note: This option is not available for base follow types of Head, Riser, or None.
Type	Select the device type based on the type of device you are programming. Refer to "Device type descriptions" on page 52 for a list of all possible device types.

Adding devices

To add a device to a programmed system:

1. Install the device on the system.
The system recognizes the new device and displays a trouble event message that indicates that there is an unprogrammed device.
2. Press Enter.
The device details screen is displayed.
3. Press Enter again, and enter a level two password (if you are not already logged on).
The Add Device screen is displayed.
4. Verify the device that you are about to add, and press Enter.
The Device programming menu displays. If the device is not a valid device, "invalid device" displays and you will be unable to program the device.
5. Program device options using Table 25 on page 76.
Some device options have a factory default setting that you can accept or change. See "Factory default settings" on page 43.

If you added a dual address device, both addresses for the device are displayed on the screen (e.g., 001/002). The first address listed is the device address you are programming. When you pick the second address to program, both addresses are still displayed but in reverse order (e.g., 002/001).

Depending on the type of device you are programming, some of the options in the Table 25 on page 76 may not be available.

6. When you have finished programming each option, choose Save. The device is added to the database and the unprogrammed device event is cleared.
7. Press the Menu button to exit menu mode.

You can remove a device from the system and delete it from the database without going into programming mode.

Removing devices

To remove a device from a programmed system:

1. Physically remove the device from the system.

The system indicates a trouble event.

Note: If the system is configured as a zoned system, the panel displays two events, one for the zone and one for the device.

2. Press Enter.

The Device Details screen is displayed. If the device condition shows as “Communications Fault,” you can delete the device from the system; otherwise, you cannot remove it.

3. Press Enter.

The Enter Password screen is displayed if you are not logged on. If you are already logged on, the Delete Device screen is displayed; go to step 5.

4. Enter a level two password.

The Delete Device screen is displayed.

5. Verify the device you are about to delete by reviewing the information on the screen. Before continuing, be sure that this is the device you want to remove. Once removed, the process cannot be reversed.
6. Press Enter to delete the device and save the change in the database.
7. Repeat these steps for each device you are removing from the system.

Advanced programming

Overview

Advanced programming lets you program the panel manually and apply custom settings. Most options have a factory default setting that you can accept or change. See “Factory default settings” on page 43.

In advanced programming, you can custom program the loop configuration options (loops, devices, zones, etc.), panel configuration options (annunciators, dialer, network, printer, etc.), panel operation options (language, marketplace, AC fail delay, etc.), panel events, and loop events. All of these options can be programmed directly from the front panel.

To do advanced programming, you must have a level two password and it is recommended that you complete the programming worksheets and have them available before beginning to program the system. Go to Appendix B “Worksheets” on page 199 to get a copy of each worksheet.

Note: Before starting the advanced programming sequence, set the time and date, and then change the default passwords. See “Setting the time and date” on page 61 and “Changing the passwords” on page 63.

Panel and loop programming options

Advanced programming lets you customize panel operation, panel configuration, and loop configuration. Programming options include:

- Annunciator class programming
- Annunciator programming
- CMS device programming
- Dialer programming
- IP Settings programming
- NAC programming
- Network programming
- Network card programming
- Printer programming

Loop configuration options include:

- Correlation groups programming
- Device programming
- Mapping
- Loop 2 enable
- Loop 3 enable
- Loop 4 enable
- Loop 2 FastGrp
- Loop 3 FastGrp
- Loop 4 FastGrp
- Loop class programming
- Zone programming
- Panel operation options include:
 - Language
 - Marketplace
 - AC fail delay
 - Zone resound
 - Reset inhibit
 - Auto signal silence
 - In-suite signal silence
 - Day start
 - Night start
 - Daylight savings
 - Date
 - Aux power reset

- LCD banner
- Key #1
- Key #2
- Standalone Op

Advanced programming for panel and loop options is covered in the following topics in this chapter.

Programming events

Advanced programming lets you create custom responses to these types of events:

- Panel events
- Loop events
- Panel event corrs (correlations)

Advanced programming for panel and loop events is covered in the last two topics in this chapter.

Changing loop configuration options

Loop configuration options

Loop configuration includes the following programmable options:

Table 27: Loop configuration options

Option	Description
Loop class	Indicates whether the loop is wired Class A/DCLA or Class B/DCLB.
Zone	Select this option to add a zone.
Correlation Groups	Select this option to add correlation groups.
Device	Select this option to add devices.
Loop 2 Enable [1]	Select Yes to enable Loop 2. Select No to disable Loop 2. [1]
Loop 2 Fst Grp [1] [2]	Select: 001 to 025 to combine loop 1 and 2 devices in the same fast groups — or — 101 to 125 to use separate fast groups for loop 2 devices.
Loop 3 Enable [1]	Select Yes to enable loop 3. Select No to disable loop 3. [1]
Loop 3 Fst Grp [1] [2]	Select: 001 to 025 to combine loops 1 and 3 devices in the same fast groups — or — 126 to 150 to use separate fast groups for loop 3 devices.
Loop 4 Enable [1]	Select Yes to enable loop 4. Select No to disable loop 4. [1]

Option	Description
Loop 4 Fst Grp [1] [2]	Select: 001 to 025 to combine loops 1 and 4 devices in the same fast groups — or — 151 to 175 to use separate fast groups for loop 4 devices.

[1] Displayed in multiple loop systems only.

[2] See “Programming fast groups for sounder bases” on page 90.

Most options have a factory default setting that you can accept or change.

See “Factory default settings” on page 43.

To change loop configuration options:

1. Press the menu button and choose Program.
2. Choose Advanced Program.
3. Enter a level two password.
4. Choose Loop Configuration.
5. Program the options.

Correlation group programming

This section includes instructions for:

- Using fast groups
- Adding members to correlation groups
- Setting the activation count
- Copying members of a correlation group
- Removing all members from a correlation group

Using fast groups

Note: To meet the UL\ULC requirement that evacuation signals activate within 10 seconds, assign sounder base detectors to “fast” correlation groups.

See “Programming fast groups for sounder bases” on page 90.

If you are new to correlation group programming, see “What is a zone?” on page 38.

Adding members to correlation groups

Correlation groups can include zones, NACs, devices, unconfigured alarm events, and the common trouble event. See the following procedure.

To add or remove members from a correlation group:

1. Press the Menu button and choose Programming.

2. Choose Advanced Program and enter the level 2 password.
3. Choose Correlation Groups and enter the correlation group number to be programmed. (Values range from 001 to 199.)
4. Choose:
 - Add/Remove Zone to add or remove a zone
 - Add/Rem Panel NAC to add or remove a NAC
 - Add/Rem Device to add or remove a device
Note: The Add/Rem device includes primary sensor, secondary sensor, and base, if applicable.
 - Add/Rem Panel Event
 - Suite Sig Sil
 - Activation Count
 - Delay
 - Copy
 - Remove All
 - Save
5. Enter the loop number (if the panel has multiple loops).
6. Enter the zone, NAC, or device number.
7. On the Status line, press Enter to select Included or Excluded:
 - “Included” adds the item to the group
 - “Excluded” removes the item from the group
8. Repeat steps 4 to 7 to add or remove other devices, zones, or NACs.
9. Repeat steps 3 to 9 to program additional correlation groups.
10. Press the Menu button to exit menu mode, or continue programming.

To add the Common Trouble Event to a correlation group:

1. Press the Menu button and choose Programming.
2. Choose Advanced Program and enter the level 2 password.
3. Choose Common Trouble then choose Trouble.
4. Choose Correlation Groups and enter the number of the correlation group to be configured.
5. Press Enter to toggle between possible values:
 - “Included” adds the item to the group
 - “Excluded” removes the item from the group
6. Repeat steps 7 to 9 to add or remove the event from any remaining correlation groups to be configured.
7. Choose Save.
8. Press the Menu button to exit menu mode or continue programming.

Setting a correlation group's activation count

A correlation group's activation count is the number of member activations that are required to activate the correlation group. The activation count is used to set up cross zoning. The following rules apply:

- The count cannot exceed the number of input members in the correlation group
- The default value is 1
- Input members can be zones, NACs, devices, unconfigured alarm events, or the common trouble event
- The activation count must be 1 for correlation groups with in-suite signal silence enabled
- The activation count must not exceed 2 for cross zoning applications and the zones should not have alarm verification per ANSI/NFPA 72-2002 6.8.5.4.3

To set the activation count:

1. Press the Menu button and choose Programming.
2. Choose Advanced Program and enter the level 2 password.
3. Choose Loop Configuration.
4. Choose Correlation Groups and enter the number of the correlation group to be programmed. (Values range from 001 to 199.)
5. Choose Activation Count and enter the activation count (values range from 01 to 99).
6. Choose Save.

To copy the members of a correlation group:

1. Press the Menu button and choose Programming.
2. Choose Advanced Program and enter the level 2 password.
3. Choose Loop Configuration.
4. Choose Correlation Groups.
5. Enter the number of the correlation group to be programmed. (Values range from 001 to 199.)
6. Choose Copy and enter the number of the correlation group to be copied.
7. Choose Save.

To remove all members from a correlation group:

1. Press the Menu button and choose Programming.
2. Choose Advanced Program and enter the level 2 password.
3. Choose Loop Configuration.
4. Choose Correlation Groups.
5. Enter the number of the correlation group. (Values range from 001 to 199.)
6. Choose Remove All. A warning message is displayed.
7. Choose Continue to remove all members from the group.

— or —

Press the Cancel button to return to the previous level without removing all members.

Note: Removing all members from a correlation group resets the activation count to 1 and disables in-suite signal silence.

Adding and removing panel events

The following panel events can be added to correlation groups in order to trigger outputs in that correlation. The outputs activate at the beginning of the event and restore when the events restore.

- Signal Silence
- Drill
- Common Alarm
- Common Supervisory
- Common Monitor
- Common Disable
- Common Trouble
- Local AC Power
- System AC Power
- Aux Power 1
- Aux Power 2

You can also configure Reset for a correlation group in two ways:

- **Reset Activate:** When an event is added to a correlation group without a configured time delay, the output activates when the reset starts and restores when the reset ends. When an event is added with a configured time delay, the output activates only after the delay time is reached.

If the delay is greater than twenty seconds, the outputs will not activate, since the delay time exceeds the reset duration.

- **Reset Restore:** When an event is added to a correlation group without a configured time delay, active outputs in the correlation are restored when the reset starts and the end of the reset activates the outputs, provided the device triggering the output is still active; otherwise, the outputs will not activate. When programmed with a time delay, the outputs are activated after the reset duration and an additional delay time assigned to the correlation group, provided the device triggering the output device is still active.

When you configure a correlation group to activate, restore, or disable with the common outputs assigned to reset activate or restore, the priorities are defined from highest to lowest, as shown below.

1. Device disable (command menu or user key)
2. A latched output
3. Activation or restore via command menu
4. Restore via user key
5. Activation via user key
6. Restore from correlation (reset restore)
7. Activation via correlation

To add or remove a panel event:

1. Press the Menu button and choose Programming.
2. Choose Advanced Program and enter the level 2 password.
3. Choose Loop Configuration.
4. Choose Correlation Groups and enter the number of the correlation group. (Values range from 001 to 199.)
5. Choose Add/Rem Panel Event.
6. Select:
 - Yes to add a panel event
 - No to remove a panel event
7. Choose Save.

Programming in-suite signal silence

In-suite signal silence is programmed using two separate menus:

- Configure the elapse timer for in-suite signal silence by displaying the Program > Advanced Program > Panel Operation menu.
- The function is enabled for individual correlation groups through the Program > Advanced Program > Loop Configuration > Correlation Groups menu.

This section provides instructions for setting both in-suite signal silence options.

Note: When setting up correlation groups for in-suite signal silence, the group's activation count must be set to 1. See "Setting a correlation group's activation count" on page 87.

To enable in-suite signal silence for a correlation group:

1. Press the Menu button and choose Programming.
2. Choose Advanced Program and enter the level 2 password.
3. Choose Loop Configuration.
4. Choose Correlation Groups and enter the number of the correlation group. (Values range from 001 to 199.)
5. Choose Suite Sig Sil.
6. Select:
 - Yes to enable in-suite signal silence.
 - No to disable it.
7. Choose Save.

To set the in-suite signal silence elapse timer:

1. Press the Menu button and choose Programming.
2. Choose Panel Operation and enter the level 2 password.
3. For the Suite Sig Sil option, enter a value from 1 to 10 minutes (the default is 10). To disable in-suite signal silence, set this option to Off.

This is a global option that sets the shutdown period during which "in suite" evacuation signals outside the alarm zone remain silenced.

Programming fast groups for sounder bases

For UL/ULC Listing, alarms are required to sound within 10 seconds after a fire is detected. This can be difficult to achieve in large systems with hundreds of sounders, unless the sounders are properly grouped.

To address this requirement, FX-64 and FX-1000 systems provide 25 high priority correlation groups per loop that can activate all sounders simultaneously. These are:

- For panels with one loop only, the fast correlation groups are Groups 001 to 025
- For panels with more than one loop, the fast correlation group options per loop are:

Loop 1: groups 001 to 025

Loop 2: groups 001 to 025 or 101 to 125 (user configurable).

Loop 3: groups 001 to 025 or 126 to 150 (user configurable).

Loop 4: groups 001 to 025 or 151 to 175 (user configurable).

In multiple loop systems, you can combine devices from loop 1, 2, 3, and 4 in correlation groups 001 to 025, or you can separate them and use groups 101 to 125 for loop 2, 126 to 150 for loop 3 and groups 151 to 175 for loop 4. See “Changing loop configuration options” on page 84.

For best performance use the fast correlation groups for bulk activations, such as entire floors and save the slower correlation groups for small sets of activations such as individual suites or hotel rooms.

Note: Be sure the Follow option for devices to be added is None, Alarm, Alarm and Verify, or Alarm and Prealarm. Be sure the Follow option is *not* set to Head or Riser. If you need to run a report to check the Follow option, see “Device Details report” on page 181. If you need to change the Follow option, see “Adding and removing devices from programmed systems” on page 79.

To add sounder base detectors to a fast group:

1. Press the Menu button and choose Programming.
2. Choose Advanced Program and enter the level 2 password.
3. Choose Correlation Groups and enter the correlation group number to be programmed.
Enter a value from:

- For panels with one loop only, the fast correlation groups are Groups 001 to 025

- For panels with multiple loops, the fast correlation groups are

Loop 1: groups 001 to 025

Loop 2: groups 001 to 025 or 101 to 125 (user configurable).

Loop 3: groups 001 to 025 or 126 to 150 (user configurable).

Loop 4: groups 001 to 025 or 151 to 175 (user configurable).

See “Programming fast groups for sounder bases” on page 90.

4. Choose Add/Remove Device.
5. Enter the loop number (if the panel has multiple loops).
6. Enter the device number.

7. Add the detector as an input and the sounder base as an output. Choose:
 Sensor to add the detector
 — or —
 Base to add the sounder base.
8. On the Status line, press Enter to select Included. This adds the device to the group.
9. Repeat steps 4 to 8 to add or remove other devices, zones, or NACs.
10. Repeat steps 3 to 9 to program additional correlation groups.
11. Press the Menu button to exit menu mode, or continue programming.

Device programming

Each device that operates on a notification appliance circuit (NAC) or device loop has operating parameters that must be set. This includes assigning a device type and label, programming event notification, etc.

Table 28: Programming devices — Device options

Option	Description
Zone	<p>Identifies the zone to which the device will be added.</p> <p>To add the device to a zone, enter the zone number.</p> <p>— or —</p> <p>If the device will not be added to a zone, select Off.</p> <p>Note: Do not mix device and zone types. For example, do not place a nonlatching supervisory device in an alarm zone. When the supervisory device activates and an alarm event is initiated, the alarm event automatically clears when the device restores without having to reset the panel.</p>
Zone secondary	<p>Identifies the zone to which the device's secondary element (if it exists) will be added.</p> <p>To add the device to a zone, enter the zone number.</p> <p>— or —</p> <p>If the device will not be added to a zone, select Off.</p> <p>Note: Do not mix device and zone types. For example, do not place a nonlatching supervisory device in an alarm zone. When the supervisory device activates and an alarm event is initiated, the alarm event automatically clears when the device restores without having to reset the panel. Be sure to name your zones appropriately in message line 1 for CO activations.</p>
Label	<p>Contains the two lines of text displayed beneath the device number on the LCD.</p> <ol style="list-style-type: none"> 1. Enter text for the device label (two lines of 20 characters). 2. When you have finished, choose Save.
Event notification	<p>Sets notification options (printer, coder, dialer, and contact ID) for the active, alarm verify, disable, maintenance, prealarm, test, trouble, and active3 for secondary events. See "Factory default settings" on page 43 for device event notification default settings.</p>

Option	Description
	<ol style="list-style-type: none"> 1. Select an event type and set its notification options. 2. Repeat until all event types have been set. 3. When you have finished, choose Save. <p>Printer: Yes or No. This controls whether event information is sent to the printer</p> <p>Coder: four-digit coded output that is played in response to alarm conditions (00-00-00-00 to 99-99-99-99)</p> <p>Dialer:</p> <ul style="list-style-type: none"> Acct 1 & 2: Event information is sent to both dialer accounts Acct 1: Event information is sent to dialer account one Acct 2: Event information is sent to dialer account two None: Event information is not sent to the dialer NET (1-8): Yes or No. Controls whether event information is sent to the connected networks CID: Contact ID event code (000 to 999)
Correlation groups	<p>Lets you add the device to (or remove it from) one or more correlation groups.</p> <ol style="list-style-type: none"> 1. Enter the number of the first correlation group to be configured. 2. To add the device to the correlation group, select Included. — or — 3. To remove the device from the correlation group, select Excluded. 4. Repeat steps 1 to 3 for any other correlation groups to be configured. 5. When you have finished, choose Save. <p>The device may include a primary element, secondary element, and base, depending on the device type and base type.</p> <p>For more information, see “What is a correlation group?” on page 39.</p>
Day sensitivity	Set the daytime smoke level sensitivity to least, less, more, normal, or most.
Night sensitivity	Set the nighttime smoke level sensitivity to least, less, more, normal, or most.
Day prealarm%	Set the daytime prealarm percentage to Off or 50, 55, 60, 65, 70, 75, 80, or 90 percent. This is the amount of smoke that indicates a prealarm event before an actual alarm event is indicated. The percentage is based on the sensitivity level selected above. For example, if you select normal sensitivity and select 50 percent for prealarm, when smoke levels reach 50% of the normal smoke level required to initiate an alarm, a prealarm event will be indicated.
Night prealarm%	Set the nighttime prealarm percentage to Off or 50, 55, 60, 65, 70, 75, 80, or 90 percent. This is the amount of smoke that indicates a prealarm event before an actual alarm event is indicated. The percentage is based on the sensitivity level selected above. For example, if you select normal sensitivity and select 50 percent for prealarm, when smoke levels reach 50% of the normal smoke level required to initiate an alarm, a prealarm event will be indicated.
Base type	Set to the type of base (standard, relay, isolator, or sounder) being used with the detector.

Option	Description
Follow	<p>This option controls the conditions that will activate the relay or sounder detector base. Select from the following values.</p> <p>Head: The base is controlled by the detector's settings:</p> <ul style="list-style-type: none"> • The base activates when the detector goes into alarm, unless the detector is set for alarm verification. • If the detector is set for alarm verification, the base activates when the detector goes into alarm verification. It does not restore, however, until the alarm restores. • The base does not respond when the detector goes into prealarm no matter how the detector is configured. Also, the base only follows the primary element of a dual element detector. Any activation from a secondary element does not trigger the base. <p>Example: When a PCD on a sounder base has a follow set to Head, the base is only triggered when a smoke event is generated. The base does not trigger when a CO event is generated.</p> <p>Riser: The base is triggered individually by the panel (sounder bases only)</p> <p>None: A correlation group triggers the base. The option "None" can be applied to both relay and sounder bases, and is used for relay bases configured as latched output devices.</p> <p>Note: All base follow settings except Head and Riser can be activated by correlation groups.</p> <p>Alarm: The base activates its relay when the detector goes into alarm. The base will not restore until the alarm event has been restored. Any activation from a secondary element (Active3) does not trigger the base. For CO device operation, see Follow CO below.</p> <p>Alarm and verify (ALM+VFY): The base activates its relay when the detector goes into alarm verify and continues when the detector goes into alarm. The base will not restore until both events have been restored.</p> <p>Alarm and prealarm (ALM+PALM): The base activates its relay when the detector goes into prealarm and continues when the detector goes into an alarm. The base will not restore until both events have been restored.</p>
Follow CO	<p>This option controls the conditions that will activate relay or sounder detector bases. Select Yes to allow the device's secondary element (example CO) to activate the base programmed functions.</p> <p>Note: This option is not available for base follow types of Head, Riser, or None.</p>
Type	<p>Select the device type based on the type of device you are programming.</p> <p>Refer to "Device type descriptions" on page 52 for a list of all possible device types.</p>

To program an input or output device:

1. Press the Menu button and choose Programming.
2. Choose Advanced Program and enter the level 2 password.
3. Choose Device.
4. If the panel has multiple loops, choose the loop to be configured.
5. Enter the device address to be configured.

For the FX-1000 panel, addresses 1 to 125 are detectors and addresses 201 to 325 are modules.

Note: The device label occupies two lines just below the device number.

6. Program each device in the system using Table 29 on page 92.

Note: If you chose a dual address device, both addresses for the device are displayed on the screen (e.g., 001/002). The first address listed is the device address you are programming. When you pick the second address to program, both addresses are still displayed but the order is reversed (e.g., 002/001).

Note: Depending on the type of device you are programming, some of the options in the table below may not be available.

7. When you finish programming an option, choose Save, then choose the next option.
8. Press the Menu button to exit menu mode, or continue programming.

Programming relay and sounder detector bases

Relay and sounder bases require some configuration not required by other devices. First, the panel does not automatically distinguish between relay and sounder bases — Both are set by default to base type “relay.” You must manually change this setting for sounder bases.

In addition, configuration is required to control how these devices are activated. Relay bases can be activated by:

- The detector to which they are attached
- One or more correlation groups

Sounder bases can be activated by:

- The detector to which they are attached
- One or more correlation groups
- The 24 volt riser

You can configure these options using the procedure given below. See Table 29 on page 92 for information on the Base and Follow options.

To change the relay/sounder base type and follow option:

1. Press the Menu button, and then choose Programming.
2. Choose Advanced Program and enter the level 2 password.
3. Choose Loop Configuration and select the loop number. (This option is displayed only if the panel has multiple loops.)
4. Choose Devices, and then enter the number of the device to be programmed. The serial number of the device is displayed.
5. Press the Enter button.

6. Choose Base Type and select either Relay or Sounder.
7. Choose Follow and select one of the types listed in Table 29 on page 92.
8. Choose Save.
9. Press the Menu button to exit menu mode, or continue programming.

Programming relay modules and bases as latched output devices

Latched outputs are relays that are configured to shut down air handlers and dampers during an alarm. The table below lists relay modules and relay bases that can be configured as latched outputs. The following table lists the device types used to configure a device as a latched output.

The latched outputs must be manually unlatched and then restored. The unlatch command affects all latched outputs system-wide. You can assign the Unlatch Outputs command to a programmable key on the front panel or to an input module. The following output modules can be configured to unlatch latched outputs: FX_NAC or FX_RLY.

For information on assigning the unlatch command to a programmable key, see “Setting up the programmable keys” on page 64.

Table 29: Output modules configurable as latched outputs

Output modules
FX_NAC
FX_RLY

Table 30: Device types for latched outputs

Type	Description
Supervised outputs (latched)	SupOut Latch. For Class B latched output modules that output an unsynchronized signal. Does not follow signal silence.
Continuous nonsilenceable (latched)	Cont NS Latch. For Class B latched output modules that output an unsynchronized signal. Does not follow signal silence.
Continuous nonsilenceable ClsA (latched)	Cont NS CIA Latch. For Class A latched output modules that output an unsynchronized signal. Does not follow signal silence.
Supervised outputs ClsA (latched)	SupOut CIA Latch. For Class A latched output modules that output an unsynchronized signal. Does not follow signal silence.
Relay nonsilenceable (latched)	Relay Latch. For Class B relay devices functioning as latched outputs. Does not follow signal silence.
Relay nonsilence NO (latched)	Relay NO Latch. For relay devices functioning as latched outputs that close when activated. Does not follow signal silence.

Type	Description
Relay nonsilence NC (latched)	Relay NC Latch. For relay devices functioning as latched outputs that open when activated. Does not follow signal silence.

To configure a relay module or base as a latched output:

1. Press the Menu button and choose Programming.
2. Choose Advanced Program and enter the level 2 password.
3. Choose Loop Configuration.
4. Choose Device.
5. If the panel has multiple loops, choose the loop to be configured.
6. Enter the device address to be configured. Device details are displayed.
7. Set the Base Type option to Relay.
8. Set the Follow option to None.
9. Set the Latched option to Yes.
10. Choose Type and select one of the Latched Outputs types listed in Table 30 on page 96.
11. Press the Menu button to exit menu mode, or continue programming.

Loops 1, 2, 3, and 4 enable loops

If your system is using multiple device loops, you must enable loops 1, 2, 3, or 4 so that they can be programmed.

To enable loops 1, 2, 3, or 4:

1. Press the Menu button and choose Programming.
2. Choose Advanced Program and enter the level 2 password.
3. Choose Loop Configuration.
4. Choose Loop 1, 2, 3, or 4 Enable.
5. Select:
 - Yes to enable the selected loop
 - No to disable the selected loop
6. Repeat steps 3 and 4 for each loop you want to enable.
7. Choose Save.
8. Press the Menu button to exit menu mode, or continue programming.

Loops 1, 2, 3, and 4 selecting loop classes

Selecting loop classes

The loop class must be programmed Class A/DCLA or Class B/DCLB based on how the devices are wired on the loop). The default setting is Class B/DCLB.

To select a loop class:

1. Press the Menu button and choose Programming.
2. Choose Advanced Program and enter the level 2 password.
3. Choose Loop Class.
4. Select the loop. If you only have one loop, the loop is automatically selected.
5. Select either Class A/DCLA or Class B/DCLB.
6. Choose Save.
7. Press the Menu button to exit menu mode, or continue programming.

Zone programming

Notes

- For background information about zones, see “What is a zone?” on page 38.
- If the system does not have zones, no programming is required in this section. If the panel is not configured for zone or zone/device reporting, programming here has no effect on the system except for CMS reporting.

Table 31: Zone programming options

Type	<p>Set the zone type to one of the following values.</p> <p>Alarm: For circuits with smoke detectors and contact devices. All activations are immediately considered as alarms. Circuit cannot be restored until devices are restored to normal and panel is reset.</p> <p>Monitor: Monitoring of normally open switches for other functions (fire door position, etc.). Not approved for use under CAN-U LC-S527 in Canada.</p> <p>Supervisory: For supervisory devices. Momentary activation of normally open devices immediately places the panel in a supervisory state and turns on the supervisory LED and relay.</p> <p>The device types of the devices in a supervisory zone determine whether the zone is latching or nonlatching. If all devices in the zone are latching devices, or if you mix latching and nonlatching devices, the zone will operate as latching.</p> <p>Waterflow: Activates alarm events when a waterflow switch closes. Select this zone type when the devices in the zone are only connected to waterflow switches.</p>
------	---

	<p>Note: Do not mix device and zone types. For example, do not place a nonlatching supervisory device in an alarm zone. When the supervisory device activates and an alarm event is initiated, the alarm event automatically clears when the device restores without having to reset the panel.</p>
Label	Enter a text label for the zone (two lines of 20 characters). When you have finished, choose Save.
Correlation groups	<p>Enter the number of the correlation group. Choose Yes or No.</p> <ul style="list-style-type: none"> • “Yes” adds the item to the group. • “No” removes the item from the group <p>When you have finished, choose Save. For more information on correlation groups, see “What is a correlation group?” on page 39.</p>
Event notification	<p>Set the active, trouble, disable, prealarm, alarm verify, maintenance alert, and test event information by choosing one and then setting the notification information. When you have finished, choose Save. See “Factory default settings” on page 43 for zone event notification default settings.</p> <p>Note: If your CMS is set to zone reporting, the event notification information sent to the receiver comes from the programming in this section.</p> <p>Printer: Yes or No. This controls whether event information is sent to the printer</p> <p>Dialer:</p> <ul style="list-style-type: none"> • Acct 1 & 2: Event information is sent to both dialer accounts • Acct 1: Event information is sent to dialer account one • Acct 2: Event information is sent to dialer account two • None: Event information is not sent to the dialer <p>NET: Yes or No. Controls whether event information is sent to the connected network</p> <p>CID: Contact ID event code (000 to 999)</p>

To program a zone:

1. Press the Menu button and choose Programming.
2. Choose Advanced Program and enter the level 2 password.
3. Choose Loop Configuration.
4. Choose Zone and enter the zone number.
5. Program each zone in the system using Table 32 on page 98.
6. When you finish programming an option, choose Save, and then continue.
7. Press the Menu button to exit menu mode, or continue programming.

Panel programming

The panel options to be configured include:

- NAC circuits (“NACs”)
- Annunciator class
- Annunciator
- Dialer and network (“CMS device”)
- Printer/FSB
- IP Settings

Most options have a factory default setting that you can accept or change. See “Factory default settings” on page 43.

Notes

- The option “CMS device” is only available if a dialer or network card is installed
- The option “Printer” is only available if a printer (RS-232) card or USB connection is installed
- The option “IP Settings” is only available if a network card is installed.

To program panel configuration options:

1. Press the Menu button and choose Programming.
2. Choose Advanced Program and enter the level 2 password.
3. Choose Panel Configuration.
4. Program the options.

NAC programming

The NAC circuits connected to the system must be programmed with the type of NAC, label, correlation groups, and event notification. Each NAC must be programmed separately.

Table 32: NAC programming options

Option	Description
Class	Select either Class A or Class B. Note: NAC 3 and 4 cannot be set to Class A. If NAC 1 and 2 are set to Class A, NAC 3 and 4 automatically configure to accept the Class A return.
Type	Set the NAC type to one of the following values. Continuous (silenceable or nonsilenceable): For strobes and notification appliances that generate a temporal pattern. Temporal (silenceable or nonsilenceable): Universal 3-3-3 pattern required for evacuation signals by NFPA 72. Used when notification appliances are not capable of generating a temporal pattern.

Option	Description
	<p>Genesis (nonsilenceable or with audible silence or with audible/visible silence): For Genesis horns and strobes and Enhanced Integrity strobes. Genesis and Enhanced Integrity appliances maintain synchronization per UL 1971. When using Genesis or Enhanced Integrity notification appliances, you must select one of the Genesis NAC types for proper system-wide strobe synchronization.</p> <ul style="list-style-type: none"> • Nonsilenceable: Horns cannot be silenced and strobes flash • Audible silence: Horns can be silenced while strobes continue to flash • Audible/visible silence: For Genesis devices only, connected horns can be silenced and strobes turn off <p>Coder (basic, continuous, 120 SPM, or temporal): Used to provide four-digit coded output in response to alarm conditions. When the device goes into alarm, the coded output is played a minimum of four times by the NAC circuit. The code comes from the active initiating device or zone. Note: The panel can only play one code at a time. For example, device 1 is coded as 1-2-3-4 and is associated with NAC1 and device 2 is coded as 5-6-7-8 and is associated with NAC2. If device 1 activates, NAC1 plays 1-2-3-4. If, while NAC1 is playing 1-2-3-4, device 2 activates, NAC2 will also play 1-2-3-4 until the rounds are complete and then both NACs will play 5-6-7-8 until those rounds are complete. If you are programming NACs as coded, remember that only one code can play at a time.</p> <ul style="list-style-type: none"> • Basic: Four rounds of the four-digit coded output are played • Continuous: Four rounds of the four-digit coded output are played and then continuous is played • 120 SPM: Four rounds of the four-digit coded output are played and then 120 times per minute is played • Temporal: Four rounds of the four-digit coded output are played, and then a temporal pattern is played <p>Continuous Non-Silenceable (Latched): For programming NAC as latched output</p> <p>City tie: Outputs an unsynchronized, 24-volt continuous (steady) signal that cannot be silenced. Select this NAC type when the NAC is connected to a city tie module.</p>
Label	Enter a text label for the NAC (two lines of 20 characters). When you have finished, choose Save.

Option	Description
Correlation groups	<p>Enter the number of the correlation group. Press Enter to toggle the group's status.</p> <ul style="list-style-type: none"> • “Included” adds the item to the group. • “Excluded” removes the item from the group <p>When you have finished, choose Exit.</p> <p>A correlation group is a collection of addressable input devices (detectors and input modules) and output devices (panel NACs, NAC modules, relay modules, sounder and relay bases). When one or more inputs become active and meet the required activation count, all outputs assigned to the group activate. As you configure the loop devices, you must correlate and assign the desired input device or zone to the correlation group that you want to activate.</p> <p>For an addressable device to activate an output, you must assign the output to a correlation group. Next, assign the device to a zone, and then assign the zone to the correlation group containing the output. You can assign inputs and outputs to multiple correlation groups. For more information on correlation groups, see “What is a correlation group?” on page 39.</p>
Event notification	<p>Set the NAC trouble, disable, and test event information when it is to be sent to a printer, dialer, or network card), by choosing one and then setting the notification information. When you have finished, choose Save. See “Factory default settings” on page 43 for NAC event notification default settings.</p> <p>Printer: Yes or No. This controls whether event information is sent to the printer</p> <p>Dialer:</p> <ul style="list-style-type: none"> • Acct 1 & 2: Event information is sent to both dialer accounts • Acct 1: Event information is sent to dialer account one • Acct 2: Event information is sent to dialer account two • None: Event information is not sent to the dialer <p>CID: Contact ID event code (000 to 999)</p> <p>NET (1-8): Yes or No. Controls whether event information is sent to the connected network</p>

To program an NAC:

1. Display the panel configuration options menu. See “Panel programming” on page 100.
2. Choose Panel NAC.
3. Enter the NAC (number) you want to program, and then press Enter.

Note: NAC 3 and 4 are not available if either NAC 1 or 2 or both are set to Class A.
4. Program each NAC in the system using Table 33 on page 100.
5. When you finish programming each option, choose Save.
6. Press the Menu button to exit menu mode, or continue programming.

Setting annunciator classes

Program the annunciator's wiring class (Class A or Class B). You must install the optional SA-CLA module if you have class annunciator wiring on the 64 point panel.

Default: Class B

To set the annunciator class:

1. Display the panel configuration options menu. See "Panel programming" on page 100.
2. Choose Ann. Class.
3. Select either Class A or Class B.
4. Program other panel configuration options or choose Save if you're finished.
5. Press the Menu button to exit menu mode, or continue programming.

Annunciator programming

Each annunciator on the annunciator loop must be programmed for type, number of expanders, label, and event notification. Up to eight annunciators can be connected on the loop and each must be programmed separately. You must also set the address on each annunciator by using the DIP switch on the back of the annunciator.

Table 33: Annunciator options

Option	Description
Annunciator type	<p>Set annunciator type to:</p> <p>Off: No annunciator is connected. If type is set to Off, Number expanders, Label, and Reporting configuration are not available.</p> <p>LCD-C: The annunciator has a display and common controls</p> <p>LCD: The annunciator has a display only (no common controls)</p> <p>LED: The annunciator has LEDs and common controls (no display)</p> <p>Graphic: Graphics controller interface for the third-party LED graphic annunciator</p>
Expanders	<p>Set expanders to None, 1, or 2. This is the number of LED expander modules you are using with the annunciator.</p>
Label	<p>Enter a text label for the annunciator (two lines of 20 characters). When you have finished, choose Save.</p>
Event notification	<p>Set the trouble event information by setting the notification information. When you have finished, choose Save. See "Factory default settings" on page 43 for annunciator event notification default settings.</p> <p>Printer: Yes or No. This controls whether event information is sent to the printer</p> <p>Dialer:</p> <ul style="list-style-type: none"> • Acct 1 & 2: Event information is sent to both dialer accounts

Option	Description
	<ul style="list-style-type: none"> Acct 1: Event information is sent to dialer account one Acct 2: Event information is sent to dialer account two None: Event information is not sent to the dialer <p>CID: Contact ID event code (000 to 999)</p> <p>NET (1-8): Yes or No. Controls whether event information is sent to the connected network</p>

To program an annunciator:

1. Press the Menu button and choose Programming.
2. Choose Advanced Program and enter the level 2 password.
3. Choose Panel Configuration.
4. Choose Annunciator.
5. Choose the annunciator you want to program.
6. Program each annunciator in the system using Table 34 on page 103.
7. When you finish programming each option, choose Save.
8. Press the Menu button to exit menu mode, or continue programming.

Central monitoring station device programming

CMS device programming

CMS devices are the devices that transmit system events to a central monitoring station's receiver. This includes the dialer and the network.

Table 34: CMS device options

Option	Description
CMS Path	<p>Type: Select from the following CMS paths.</p> <ul style="list-style-type: none"> Telco Only (Default) Used to select a single CMS Path using the Telco Dialer configured Dialer Type settings. A SA-DACT must be installed in the panel. If Telco Only is selected as the CMS path, all eight IP accounts become inactive and disabled. IP/Telco Used to select IP as the primary CMS Path and Telco as the backup CMS path.

Option	Description																
	<ul style="list-style-type: none"> <li data-bbox="597 212 1484 348">• Telco/IP Used to select Telco as the Primary CMS Path and IP as the Backup CMS path for event transmission to a Central Station per all applicable codes and standards. Notes System events are routed to the selected backup only when all primary configured accounts have exhausted their programmed Retry Count. This could be due to an abnormal condition not allowing the configured system to acknowledge a successful transmission. Active Dialer Line faults are not reported using the IP Receiver when the dialer fails. Subsequent events after the dialer faults are reported using the IP Receiver. <li data-bbox="597 684 1484 884">• IP Only Used to select a single CMS Path using the Telco Dialer configured IP Dialer Settings. An SA-ETH must be installed in the panel. If IP Only is selected as the CMS path, both Telco accounts are deactivated by setting the Dialer Mode property to None. If the backup IP account is disabled, default values will be populated once IP Only is selected. <li data-bbox="597 915 1484 1178">• Telco and IP Used to select both Telco and IP active accounts for the CMS Path. Select this option if the following is required for the system application: <ul style="list-style-type: none"> <li data-bbox="646 1052 1230 1083">1. A primary/backup configuration is not needed. <li data-bbox="646 1104 1455 1178">2. Event transmissions are needed to go out concurrently over both mediums. 																
Dialer	See “Dialer programming” on page 107.																
Network	See “CMS network (transmitter) programming” on page 109.																
Swinger shutdown	<p data-bbox="597 1293 1393 1356">Set swinger shutdown to Off or 1 to 255 repetitions. When you have finished, press Enter to save.</p> <p data-bbox="597 1377 1406 1440">Note: Off is the only acceptable setting for UL/ULC installations. See “UL/ULC programming requirements” on page 37 for details.</p> <p data-bbox="597 1461 1484 1545">This automatically inhibits the number of consecutive times a single trouble event is transmitted over a 24-hour period before it is no longer sent. Some trouble events are not affected when swinger shutdown is set. They are:</p> <table data-bbox="597 1566 1276 1883"> <tbody> <tr> <td data-bbox="597 1566 821 1598">- Loop 1 initializing</td> <td data-bbox="1040 1566 1276 1598">- Loop 4 over limits</td> </tr> <tr> <td data-bbox="597 1608 862 1640">- Loop 1 uncfgrd alarm</td> <td data-bbox="1040 1608 1276 1640">- Loop 4 device 000</td> </tr> <tr> <td data-bbox="597 1650 821 1682">- Loop 1 over limits</td> <td data-bbox="1040 1650 1235 1682">- System startup</td> </tr> <tr> <td data-bbox="597 1692 829 1724">- Loop 1 device 000</td> <td data-bbox="1040 1692 1130 1724">- Reset</td> </tr> <tr> <td data-bbox="597 1734 821 1766">- Loop 2 initializing</td> <td data-bbox="1040 1734 1243 1766">- Reset/Sil inhibit</td> </tr> <tr> <td data-bbox="597 1776 821 1808">- Loop 2 over limits</td> <td data-bbox="1040 1776 1219 1808">- Panel silence</td> </tr> <tr> <td data-bbox="597 1818 862 1850">- Loop 2 uncfgrd alarm</td> <td data-bbox="1040 1818 1235 1850">- Program mode</td> </tr> <tr> <td data-bbox="597 1860 829 1892">- Loop 2 device 000</td> <td data-bbox="1040 1860 1219 1892">- Signal silence</td> </tr> </tbody> </table>	- Loop 1 initializing	- Loop 4 over limits	- Loop 1 uncfgrd alarm	- Loop 4 device 000	- Loop 1 over limits	- System startup	- Loop 1 device 000	- Reset	- Loop 2 initializing	- Reset/Sil inhibit	- Loop 2 over limits	- Panel silence	- Loop 2 uncfgrd alarm	- Program mode	- Loop 2 device 000	- Signal silence
- Loop 1 initializing	- Loop 4 over limits																
- Loop 1 uncfgrd alarm	- Loop 4 device 000																
- Loop 1 over limits	- System startup																
- Loop 1 device 000	- Reset																
- Loop 2 initializing	- Reset/Sil inhibit																
- Loop 2 over limits	- Panel silence																
- Loop 2 uncfgrd alarm	- Program mode																
- Loop 2 device 000	- Signal silence																

Option	Description
	<ul style="list-style-type: none"> - Loop 3 initializing - Loop 3 uncfgd alarm - Loop 3 over limits - Loop 3 device 000 - Loop 4 initializing - Loop 4 uncfgd alarm - Date - Drill - Walk test - Test fire - Time - Clear history - Common alarm - Common disable - Common monitor - Common supervisory - Common trouble - Battery charger - Battery low - Battery missing - Local AC power - System-wide AC power - Self test fault - Dialer dsbl/rem disc - Dialer normal test - Dialer abnormal test - Dialer configuration
Event notification	<p>Note: Programming event notification here is only required if you selected “Event” as your dialer account or network event notification setting. See “Dialer programming” on page 107.</p> <p>Set the alarm, supervisory, monitor, trouble, disable, prealarm, alarm verify, maintenance alert, and test event information by choosing one and then setting the notification information. When you have finished, choose Save. See “Factory default settings” on page 43 for CMS device event notification default settings.</p> <p>Dialer:</p> <ul style="list-style-type: none"> • Acct 1 & 2: Event information is sent to both dialer accounts • Acct 1: Event information is sent to dialer account one • Acct 2: Event information is sent to dialer account two • None: Event information is not sent to the dialer <p>NET (1-8): Yes or No. Controls whether event information is sent to the connected network</p> <p>CID: Contact ID event code (000 to 999)</p>

To program CMS devices:

1. Press the Menu button and choose Programming.

2. Choose Advanced Program, and then enter the level 2 password.
3. Choose Panel Configuration.
4. Choose CMS Device.
5. Choose the option you want to program.
6. Program each device and option using Table 35 on page 104. For dialer options, see Table 36 below. For network options, see Table 37 on page 110.
7. After programming each device option, choose Save.
8. Press the Menu button to exit menu mode, or continue programming.

Dialer programming

The dialer has a number of options that you can program. Use the dialer to send event information to the central monitoring station. You can also use it as a modem for dial-in programming and status and report retrieval. To program the dialer (DACT), you must install and enable the SA-DACT.

Table 35: Dialer programming options

Option	Description
Type	<p>Set the dialer type to one of the following values.</p> <p>Dual line: Uses LINE 1 and LINE 2 to transmit events to the central station receiver and performs modem functions. In this mode, the dialer supervises and reports faults on both lines.</p> <p>Single line: Uses LINE 1 only to transmit events to the central station receiver and performs modem functions. In this mode, the dialer supervises and reports faults only on LINE 1.</p> <p>Modem only: Dialer provides interface for outbound communications and the ability for dial-in programming and status and report retrieval. If Modem Only is selected, only Rings to Answer, Ring Type, and Callback Number can be programmed. No other dialer options are displayed in the menu. The modem function only works with LINE 1. In this mode, neither line is supervised.</p> <p>None: No dialer is installed or if a dialer is installed, disables the dialer.</p>
Account 1 and 2	<p>Program account 1 options, and then program account 2 options. When you have finished programming each account, choose Save.</p>
Account ID	<p>Enter account 1 and 2's four-digit ID code. FFFF is not valid.</p>
Primary receiver number	<p>Enter the primary receiver's phone number. This can contain up to 20 digits (0-9, *, #, and ,). The comma causes a two-second delay in dialing. The number or hash symbol (#) and the asterisk symbol (*) are used with calling feature codes and services. Consult your telephone service provider.</p> <p>Enter the secondary receiver's phone number. This can contain up to 20 digits (0-9, *, #, and ,). The comma causes a two-second delay in dialing. The number or hash symbol (#) and the asterisk symbol (*) are used with calling feature codes and services. Consult your telephone service provider.</p>

Option	Description
Secondary receiver number	<p>CID: Contact ID is the alarm format that the monitoring facility's Digital Alarm Communicator Receiver (DACR) will receive. See "Default contact ID event codes" on page 49.</p> <p>Set send restorals to:</p>
Format	<p>Yes: Sends off-normal event restorals to the monitoring facility DACR. Required setting for UL/ULC installations. See "UL/ULC programming requirements" on page 37 for details.</p>
Send restorals	<p>No: Does not send off-normal event restorals to the monitoring facility DACR</p> <p>Set retry time to 1 to 45 seconds. Specifies the wait time between each time the dialer attempts a connection to the DACR. See "UL/ULC programming requirements" on page 37 for details.</p>
Retry time seconds	<p>Set the retry count to 5 to 10 attempts. Specifies how many times the dialer will attempt to call the DACR before timing out.</p> <p>Set event notification (event reporting) to:</p>
Retry count	<p>Device: Only device information is reported or transmitted, no zone information. This setting uses device event notification settings for reporting events. Make sure your device event notification settings are correct. See "Central monitoring station device programming" on page 104.</p>
Event notification	<p>Zone: When a device is a member of a zone, only the zone information is reported or transmitted. Device information is not reported or transmitted. This setting uses zone event notification settings for reporting events. Make sure the zone event notification settings are correct. See "Loop event programming" on page 127.</p> <p>Event: Only the event type (alarm, supervisory, trouble, etc.) is reported or transmitted, no device or zone information. This setting uses the CMS event notification settings for reporting events. Make sure the event notification settings are correct. See "Central monitoring station device programming" on page 104.</p>
Line 1 and 2	<p>Program line 1 options, and then program line 2 options. When you have finished programming each line, choose Save.</p>
Dialing:	<p>Select Tone or Pulse dialing.</p>
Cut duration/supervision	<p>Set the cut duration/supervision to Off or 10 to 120 seconds. Specifies the length of time a phone line trouble is detected before reporting the trouble.</p>
Dial Tone wait	<p>Set tone wait to Off or 0 to 30 seconds. Specifies how long the dialer waits to get a dial tone.</p>
Call disconnect seconds	<p>Set call disconnect to Off or 0 to 45 seconds. Specifies the length of time the dialer seizes the line (to disconnect parallel devices) before attempting to dial out.</p>
Test frequency hours	<p>Set test frequency to 0 to 240 hours. Specifies how often the dialer performs a test call. The default setting is 6 hours to comply with agency requirements. See "UL/ULC programming requirements" on page 37 for details.</p>
Test time	<p>Set the test time to the desired time of day for running the test.</p>

Option	Description
Rings to answer	Set rings to answer to Off or 0 to 15 rings. Specifies how many rings before the dialer answers incoming calls.
Ring type	Set ring type to Any or Normal. Specifies the type of ring expected when an incoming call is received.
Callback	Select Enabled or Disabled to enable or disable callback security. With callback security enabled, the dialer will answer an incoming call, and then hang up and redial the callback number in an attempt to connect to the PC running the configuration utility. Use this feature to increase security and to limit your connect to only the PC at the preprogrammed number.
Callback number	Enter the callback phone number (up to 20 digits). This specifies the phone number that is used for call back.

Note: Select Off to set to 0 wait time, no frequencies, or no occurrence.

To program the dialer:

1. Press the Menu button and choose Programming.
2. Choose Advanced Program and enter the level 2 password.
3. Choose Panel Configuration
4. Choose CMS Device.
5. Choose Dialer.
6. Program the dialer using Table 36 on page 107. For dialer default settings, see “Factory default settings” on page 43.
7. When you have finished programming each option, choose Save.
8. Press the Menu button to exit menu mode, or continue programming.

CMS network (transmitter) programming

Note: Connecting to a central monitoring station (CMS) using a TCP/IP Ethernet network does not comply with CAN/ULC S559 3rd edition requirements.

The information programmed here pertains to the central monitoring station (CMS) network that the control panel uses to communicate with the CMS. This is a TCP/IP Ethernet network. Event information is sent to the CMS just as it is when using a dialer; however, the transmission is over an Ethernet network rather than the telephone lines.

To program the panel for network reporting, you must install and enable the optional SA-ETH Ethernet module. Once installed, program only the network card connected to a compatible network receiver, as listed in the appropriate compatibility guide.

Obtain the following information from the central monitoring station's network administrator when programming FireWorks.

- An IP address
- Port number
- Receiver number
- Line number

For Sur-Gard receivers, download the *FX IP Dialer Configuration Worksheet*, (P/N 3102788) from the FX series website (<http://kiddefx.kidde.com/>) to guide you through what information to gather.

Notes

- CID is the only format that can be transmitted to the CMS over an Ethernet network.
- When the CMS account is configured as FireWorks, you must enter a different port number for each account. If you enter the same port number for multiple accounts, the panel will enable one account and disable all others.
- Firmware version 4.3 and above: When configuring FireWorks receivers, the primary port number and IP address should *not* be same as the secondary Port number and IP address for any IP account. By default, the port number is 3061 and it must be updated to a unique port number when FireWorks accounts are configured.
- Outputs activation state will not be sent to CMS.

Table 36: CMS network (transmitter) programming options

Option	Description
Type	Sur-Gard: Used to select Sur-Gard as the IP receiver. FireWorks: Used to select FireWorks as the IP receiver.
Enabled	Yes: Enables the CMS network operation No: Disables the CMS network operation
Account ID	Type the account's four-digit customer hexadecimal identification number. The properties are different depending on whether you have Sur-Gard or FireWorks selected as the IP Receiver. The Account ID must be unique for each account. FireWorks Possible values: 0000 to FFFF Default: FFFF Note: FFFF is reserved. Use FFFF only if you do not want to send events to this account. Sur-Gard Possible values: 0000 to 9999 Default: 0000

Option	Description
Max Attempts	If the IP Receiver Type is set to Sur-Gard, the property specifies how many times the IP receiver service attempts to send a dialer message before reporting a trouble condition. Enter a number from 1 to 10, with 5 being the default.
Send restorals	<p>Set send restorals to:</p> <p>Yes: Sends off-normal event restorals to the monitoring facility DACR</p> <p>No: Does not send off-normal event restorals to the monitoring facility DACR</p>
Event notification	<p>Set event notification (event reporting) to:</p> <p>Device: Only device information is reported or transmitted, no zone information. This setting uses device event notification settings for reporting events. Make sure the device event notification settings are correct. See “Central monitoring station device programming” on page 104.</p> <p>Zone: When a device is a member of a zone, only the zone information is reported or transmitted, no device information. This setting uses zone event notification settings for reporting events. Make sure the zone event notification settings are correct. See “Central monitoring station device programming” on page 104.</p> <p>Event: Only the event type (alarm, supervisory, trouble, etc.) is reported or transmitted, no device or zone information. This setting uses the CMS event notification settings for reporting events. Make sure the event notification settings are correct. See “Central monitoring station device programming” on page 104.</p>
Hello time	<p>Specifies the amount of time in between “hello” messages sent by the panel to the CMS to maintain communications. The time must be less than the hello timeout set on the CMS, otherwise the CMS will lose communication with the panel. Hello Time is also referred to as the Heartbeat for Sur-Gard applications.</p> <p>FireWorks</p> <p>Possible values: 10 to 255</p> <p>Default: 25</p> <p>Sur-Gard</p> <p>Possible values: 1 to 7200</p> <p>Default: 60</p> <p>Note: If the firmware version of the OH2000 line card (OH-TCP/IP-LC) is earlier than V2.2, set the Hello Time value to 75 and the line card's line cut timer value to 175.</p>

Option	Description
Timeout seconds	<p>Type how long you want the control panel to wait for an acknowledge signal from the central station receiver over a TCP/IP connection before indicating a trouble event. The properties are different depending on whether you have Sur-Gard or FireWorks selected as the IP Receiver. Time Out is also referred to as Supervision Timeout for Sur-Gard applications. Values indicate seconds.</p> <p>FireWorks</p> <p>Possible values: 31 to 255</p> <p>Default: 40</p> <p>Sur-Gard</p> <p>Possible values: 1 to 86400</p> <p>Default: 120</p> <p>Note: If the firmware version of the OH2000 line card (OH-TCP/IP-LC) is earlier than V2.2, set the Time Out value to 60 and the line card's line cut timer value to 175.</p>
DNIS Enable	<p>If the IP Receiver Type is set to Sur-Gard, the property allows you to enable or disable the Dialed Number Identification Service (DNIS).</p> <p>Possible values: Enable Yes or Enable No</p> <p>Default: Enable No</p>
DNIS Number	<p>If the IP Receiver Type is set to Sur-Gard, enter a 10-digit hexadecimal number that is used by the central station to determine the source of an inbound call. The default setting is 0000000000</p>
Primary Receiver	<p>This property allows you to configure primary Sur-Gard or FireWorks IP receivers.</p>
IP	<p>Enter the IP address for the CMS. This number is provided by the central station.</p> <p>Possible values: 0.0.0.0 to 255.255.255.255</p> <p>Default: 192.168.1.254</p>
TCP/IP port	<p>Type the central station receiver's port number. This number is provided by the central station.</p> <p>Possible values: 1025 to 65535, 1024 is not allowed</p> <p>Default setting: 3061</p>
Response Time	<p>This property is only available if the IP Receiver Type is set to Sur-Gard. Enter or select the amount of time for receiving a reply from the receiver. Typically, the default is not changed unless communication issues arise because of retries. When the time expires, the panel retries communication with the alternate server for the Maximum Attempts configured. If the retries fail, the panel generates a trouble event.</p> <p>Possible Settings: 1 to 300</p> <p>Default Setting: 5</p>

Option	Description
Account Code	<p>This property is only available if the IP Receiver Type is set to Sur-Gard. Enter the account code that identifies the CMS receiver. The receiver account code, also referred to as Fibro Account Number, is provided by the central monitoring station.</p> <p>Possible Settings: Up to a 10 digit hexadecimal number</p> <p>Default Setting : 0000000000</p> <p>Note: Account codes of less than 10 digits will always contain leading 0's.</p>
Secure Comm	<p>This property is only available if the IP Receiver Type is set to Sur-Gard. The Secure Communication property specifies whether you want to encrypt the IP receiver connection. Select Yes to display the Primary Encryption Key property that will enable encrypted communication between the panel and the central monitoring station.</p> <p>Possible settings: Yes or No</p> <p>Default Setting : Yes</p>
Encryption Key	<p>This property is only available if the IP Receiver Type is set to Sur-Gard, and the Secure Communication is set to Yes. Enter the encryption key number provided by the CMS that will enable encrypted communication between the panel and the CMS.</p> <p>Possible Settings: Up to 32 digit hexadecimal number</p> <p>Default Setting : 00000000000000000000000000000000</p>

Option	Description
Test Message	<p>If the IP Receiver Type is set to Sur-Gard, the Test Message property is displayed. The Test Message property specifies whether you want the IP receiver service to transmit an automatic test message and when.</p> <p>Enabled: Used to select if a test message should be sent.</p> <p>Possible settings: Yes or No</p> <p>Default Setting : No</p> <p>Normal: The Normal message property specifies the dialer test message that the IP receiver service sends if the system is in the normal state when the automatic test signal transmission is initiated.</p> <p>Possible settings: 9-digit decimal number- 000000000 to 999999999</p> <p>Default Setting : 160200000</p> <p>Abnormal: The Abnormal message property specifies the dialer test message that the IP receiver service sends if the system is not in the normal state when the automatic test signal transmission is initiated.</p> <p>Possible settings: 9-digit decimal number- 000000000 to 999999999</p> <p>Default Setting : 160800000</p> <p>Test Freq: Specifies how often you want the IP receiver service to transmit a test signal to the selected CMS account.</p> <p>Possible settings: 1 to 45 days</p> <p>Default Setting : 01</p> <p>Test Time: Specifies the time you want the IP receiver service to transmit the first test signal to the selected CMS account.</p> <p>Possible settings: 00:00 to 23:59</p> <p>Default Setting : 12:00 (12:00 PM)</p> <p>Mask Mon Evnts: The Mask Monitor Events property specifies whether you want the IP receiver service to ignore active monitor events when determining whether to send the abnormal periodic test message.</p> <p>Possible settings: Yes or No</p> <p>Default Setting : No</p>
Receiver number	<p>If the IP Receiver Type is set to FireWorks, the property specifies the CMS receiver number that receives system event messages. This number is part of the receiver message.</p> <p>Enter the CMS receiver number (0 to 9999) assigned to this panel by the CMS administrator.</p>
Line number	<p>If the IP Receiver Type is set to FireWorks, the property specifies the receiver's line number where system event messages are sent.</p> <p>Enter the CMS receiver line number (0 to 9999) assigned to this panel by the CMS administrator.</p>

To program the CMS network (transmitter):

1. Press the Menu button and choose Programming.

2. Choose Advanced Program and enter the level 2 password.
3. Choose Panel Configuration.
4. Choose CMS Device.
5. Choose Network, and then select a network from the list (1 through 8).
6. Program the network using Table 37 on page 110. For network default settings, see “Factory default settings” on page 43.
7. When you have finished programming each option, choose Save.
8. Press the Menu button to exit menu mode, or continue programming.

Printer programming

If a printer is connected to the system, you must set the printer type and configure printer event notification options. This controls where printer trouble events are sent and displayed. To communicate with a printer, you must install the optional SA-232 module in the panel and connect it to a compatible serial (RS-232) printer or install the optional SA-USB card in the panel and connect it to a compatible USB printer.

To program a printer/FSB:

1. Display the panel configuration options menu. See “Panel programming” on page 100.
2. Choose Printer/FSB.
3. Choose Type.
4. Select the printer type.
 - Supervised: The printer connection is supervised for a single open and positive ground (refer to the printer’s switch settings)
 - Unsupervised: The printer connection is not supervised
 - None/CU: There is no printer or you are connecting a computer running the configuration utility to the panel
 - FSB Unsupervised: Used to connect to the Field Server Bridge
5. Choose Event Notification.
6. Set printer trouble event notification. See “Factory default settings” on page 43 for printer event notification default settings.

Printer: Yes or No. This controls whether event information is sent to the printer
7. Choose Save (on the Printer menu).
8. Press the Menu button to exit menu mode, or continue programming.

IP programming

If you are using the optional Ethernet network card (SA-ETH), you must configure the IP Settings so that it can communicate with the network. You can choose static IP or dynamic IP (DHCP).

Contact your network administrator to obtain this information or use the default settings. You can also use the network card to send event information to a central monitoring station, download to the panel from the configuration utility, or upload and view system reports using the configuration utility. To use the configuration utility (CU), the dynamic IP (DHCP) must be disabled or the CU must be connected in the same DHCP network as the panel to allow communication between the CU computer and the panel.

Note: If the firmware version of the OH2000 line card (OH-TCP/IP-LC) is earlier than V2.2, set the Hello Time value to 75 and the line card's line cut timer value to 175.

Table 37: IP Settings options

Option	Description
IP	<p>Configure the following to use static IP. The default settings are shown below.</p> <p>IP: 192.168.001.003</p> <p>Mask: 255.255.255.000</p> <p>Gateway: 000.000.000.000</p>
DHCP Mode	<p>Set the DHCP options for dynamic IP so that the panel IP address, Subnet Mask, and Gateway details can be obtained from the DHCP server. The panel will renew the IP address from the DHCP server every 60 minutes. If the panel fails to renew the IP address after 5 tries, the DHCP service will be restarted. The default IP setting is DHCP Mode for a newly added panel.</p> <p>Note: The panel requests a new IP address from the DHCP server during startup, power cycle, or when DHCP is switched from static mode (disabled) to dynamic mode (enabled).). If a DHCP Communication fault is reported during a network change, then use one of the these methods to clear the fault.</p> <p>Yes: Assigns the panel IP address, Subnet Mask, and Gateway details obtained from the DHCP server.</p> <p>No: Disables the dynamic IP.</p>
DHCP Super	<p>Sets the DHCP SUPV options. DHCP must be enabled to use this feature.</p> <p>Yes: If the panel fails to renew the IP address after 5 tries, the DHCP service will be restarted. A DHCP communication fault will be reported to the panel if the panel cannot talk to the DHCP server after the retry count of 5 times. Once the panel can communicate with the DHCP server, the fault is restored. The default setting is Enable.</p> <p>No: Provides no supervision of the DHCP (default setting).</p>
DNS IP Settings	<p>Configure the following DNS IP settings. The default settings are shown below.</p>

Option	Description
	Pre: 192.168.001.001 Alt: 000.000.000.000
DNS DYNAMI	Set the DNS options if using a domain name server in your system. Yes: Used when a domain name server is being used in your system using dynamic IP services (default setting). No: Used when no domain name server is being used in your system (default setting).
DNS SUP	Sets the DNS SUPV options. DNS must be enabled to use this feature. DNS supervision is only available if the default DNS IP settings are used. If the setting are manually set, supervision is not supported. Yes: Enables supervision of the DNS Server. No: Provides no supervision of the DNS Server (default setting).
Cloud Conn	Used to connect or disconnect the panel from the cloud using the KESMobile or Web Portal applications. The default setting is No. Yes: Used with the KESMobile and Web Portal applications to connect the panel to the cloud. No: Used with the KESMobile and Web Portal applications to disconnect the panel from the cloud.
PORT CU	Used to set the port that the CU communicates through to the panel. The default is 02505.
Save	Used to save changes to the panel settings.

To program network receivers using static IP:

1. Display the panel configuration options menu. See “Panel programming” on page 100.
2. Choose IP Settings, and then choose IP.
3. Enter the network card’s IP address.
4. Choose MSK.
5. Enter the network card’s subnet mask number.
6. Choose GWY.
7. Enter the network card’s gateway number.
8. Choose Save.
9. Press the Menu button to exit menu mode, or continue programming.

To program network receivers using dynamic IP (DHCP):

1. Display the panel configuration options menu. See “Panel programming” on page 100.
2. Choose IP Settings.
3. Choose DHCP.

4. Choose Enable to select using dynamic IP. Choose Disable to use static IP.
5. Choose DHCP Supv.
6. Choose Enable to supervise the DHCP connections. Choose Disable to not supervise the DHCP connections.
7. Choose Save.
8. Press the Menu button to exit menu mode, or continue programming.

To program network receivers using a domain name server (DNS):

1. Display the panel configuration options menu. See “Panel programming” on page 100.
2. Choose IP Settings.
3. Choose DNS.
4. Choose Enable to select using dynamic IP. Choose Disable to use static IP.
5. Choose DNS Spvr.
6. Choose Enable to supervise the DNS connections. Choose Disable to not supervise the DNS connections.
7. Choose Save.
8. Press the Menu button to exit menu mode, or continue programming.

Port CU programming

To communicate with the CU, you must enter the same TCP/IP port number that you defined in the CU's TCP IP Port field.

To set the port CU:

1. Display the panel configuration options menu. See “Panel programming” on page 100.
2. Choose Port CU.
3. Enter the TCP/IP port number (1025 to 65535) that you entered in the Configuration Utility. The default is 2505. (Ports 1 to 1024 are reserved.)

Setting the Lock Remote Read function

Lock remote read controls incoming TCP/IP communications when a network card is installed and it is connected to a LAN or WAN. It restricts telnet, ping, and CU read requests at the panel so that unwanted access to the panel is restricted, almost like a firewall.

Note: If lock remote read is set to Yes, it remains active when no one is logged on to the panel or when someone uses a level one password to log on. When you log with a level two password, all communication options are available and there are no restrictions.

To set the Panel Configuration lock remote read option:

1. Display the panel configuration options menu. See “Panel programming” on page 100.

2. Choose Lock Rmt Read.
3. Select either:
 - Yes: telnet, ping, and CU read access to the panel are restricted.
 - No: telnet is restricted, but ping and CU read access to the panel are allowed.
4. Program other panel configuration options or choose Save if you're finished.
5. Press the Menu button to exit menu mode, or continue programming.

AC voltage programming

AC voltage is used to select the rated voltage of the mains supply connected to the control panel. The possible values are 110, 115, 120, 220, 230, and 240 VAC.

Note: Use 110, 115, and 120 only on 120 VAC control panel models. Use 220, 230, and 240 only on 230 VAC control panel models.

To set the AC voltage:

1. Display the panel configuration options menu. See "Panel programming" on page 100.
2. Choose AC Voltage.
3. Select 110, 115, 120, 220, 230, or 240.
4. Program other panel configuration options or choose Save if you're finished.
5. Press the Menu button to exit menu mode, or continue programming.

Panel operation programming

The panel operation options control how the panel operates. Most options have a factory default setting that you can accept or change. See "Factory default settings" on page 43.

Table 38: Panel operation options

Option	Description
Language	Select the desired display language: English, French, Portuguese, or Spanish.
Marketplace	Select the desired marketplace: US, CANADA, or Intl. (International)

Option	Description
AC fail delay	<p>Set the AC fail delay time to:</p> <p>Off: Off-premises notification of an AC power failure is immediate. The “off” setting is not acceptable for UL/ULC installations. See “UL/ULC programming requirements” on page 37 for details.</p> <p>1 to 15 hours: Delays the off-premises notification of an AC power failure by the time period selected.</p> <p>Note: The programmed delay in reporting an AC fail condition is applicable only when the system is normal (no events on the panel). If the system is in off-normal state (one or more events on panel), then the AC fail condition shall be reported immediately.</p>
Zone resound	<p>Set zone resound to:</p> <p>On: NACs resound each time a device in the zone goes into alarm even if they were silenced.</p> <p>Off: Inhibits the NACs from turning on again (after they were silenced) when a second device in the zone goes into alarm. The “off” setting is not acceptable for UL/ULC installations. See “UL/ULC programming requirements” for details.</p>
Reset inhibit	<p>Set the time to:</p> <p>Off: Panel reset is operational immediately after NACs turn on.</p> <p>1 minute: Panel reset is operational one minute after NACs turn on.</p>
Auto signal silence	<p>Set auto signal silence to:</p> <p>Off: Does not allow the panel to automatically silence the signals.</p> <p>5 to 30 minutes: Allows the panel to automatically silence the signals after the selected time period expires.</p>
Suite signal silence	<p>Set the timer duration. The range of possible values is 1 to 10 minutes. The default value is 10 minutes.</p>
Daytime start	<p>Set the start time for daytime sensitivity.</p>
Nighttime start	<p>Set the start time for nighttime sensitivity.</p>
Date	<p>Set the date format to:</p> <p>U.S.: MM/DD/YYYY</p> <p>Canada: DD/MM/YYYY</p>
LCD banner	<p>Enter the desired banner text for line one and line two using the keypad. Each line can have up to 20 characters. When you have finished, choose Save. The LCD banner does not display when the panel is in any off-normal state.</p>
Aux power reset	<p>On: “Reset” temporarily turns off the resettable aux power output. This is required when the output is used for powering four-wire smoke or four-wire duct smoke detectors.</p> <p>Off: “Reset” does not turn off the resettable aux power output. This is required when the output is used to power remote annunciators.</p>
Event notification	<p>Set event notification to:</p>

Option	Description
Standalone mode	<p>Zone: When a device is a member of a zone, only the zone information is sent to the LCD, LEDs, printer, and dialer. Note, device level reporting configuration is not available.</p> <p>Zone/device: Zone information is sent to the LCD and LEDs. Device information is sent to the printer and dialer. Zone/device reporting locations can be configured through custom programming.</p> <p>Device: Only device information is reported, no zone information.</p> <p>LED annunciator operation note: If you are using the optional LED expanders, the zone LEDs are assigned to device addresses 1 to 32 on loop 1. For example, zone 1 LEDs (red and yellow) are assigned to device 1 on loop 1. If the device is a dual element detector (single address), then only the primary element is assigned to zone LED. All activations from the secondary element are ignored by the zone LED.</p> <p>Remote annunciator operation note: If you are using the optional remote annunciators, when an event takes place on loop 1, the loop displays on the annunciator LCD as loop 17 (not loop 1). The device number of the device reporting the event is the correct device number. So, if an event takes place on loop 1, the remote annunciators will display it as loop 17. Loop 2 events will display on the annunciator LCD as loop 2 events. Loop 3 events will display on the annunciator LCD as loop 3 events. Loop 4 events will display on the annunciator LCD as loop 4 events.</p> <p>When Standalone mode is selected Yes, and an SLC (loop) card loses communication with the panel for more than 18 seconds, the SLC card will enter standalone mode of operation. In this mode, the panel will:</p> <ul style="list-style-type: none"> • Enter standalone alarm mode if the determined “alarm” input is part of standalone alarm configuration matrix. • Perform loop startup, closing isolators, monitoring input (Query alarm and Query status signature commands will be used for alarm confirmation) and activating outputs during standalone alarm condition • Not perform device startup, configuration or supervision operations. Device supervision (involving hardware type, personality, or configuration) is not performed during this mode. • Not perform any find serial number or find new status operations so that these statuses will remain available for use by the panel’s loop controller code when communication restores. • Trigger outputs and relay groups based on the configuration provided by panel. • Generate routine sync strobe Signature messages. Synchronization will only be maintained on a per SLC card basis. • Display a Loop Card Fault on the panel with a Communication Fault in the details. <p>Note: Refer to “Device type descriptions” on page 52 for device types supported by Standalone mode.</p>
Save	Save your option settings.

To program Panel Operation options:

1. Press the menu button and choose Program.
2. Choose Advanced Program.
3. Enter a level two password.
4. Choose Panel Operation.
5. Program the options using Table 39 on page 120.
Not all options shown in the table will be displayed on all systems.
6. When you finish programming each option, choose Save.
7. Press the Menu button to exit menu mode, or continue programming.

Event programming

Panel event programming

Panel events, such as reset, system startup, and battery low have an event notification setting for contact ID, dialer, NET, and printer, which controls where the event is sent when it takes place. Each event has a factory default setting that can be used with no additional programming (see Table 40 and Table 41).

Table 39: Default panel event settings

Panel event	Printer	Dialer	NET (1-8)	CID
Alarm ON	Yes	Acct 1	Yes	115
Aux. power 1 (disable)	Yes	None	No	n/a
Aux. power 1 (trouble)	Yes	Acct 1	No	312
Aux. power 2 (disable)	Yes	None	No	n/a
Aux. power 2 (trouble)	Yes	Acct 1	No	312
Battery charger (disable)	Yes	None	No	n/a
Battery charger (trouble)	Yes	Acct 1	No	309
Battery low (disable)	Yes	None	No	500
Battery low (trouble)	Yes	Acct 1	No	302
Battery missing (disable)	Yes	None	No	n/a
Battery missing (trouble)	Yes	Acct 1	No	311
Clear history	No	Acct 1	No	621
Cloud Provision Fault	Yes	None	No	354
Cloud Communication Fault	Yes	None	No	354
Panel Certificate Fault	Yes	None	No	354

Panel event	Printer	Dialer	NET (1-8)	CID
Common alarm	No	Acct 1	No	110
Common disable	No	Acct 1	No	500
Common monitor	No	None	No	n/a
Common supervisory	No	Acct 1	No	200
Common trouble	No	None	No	n/a
Common trouble for network dialer	Yes	None	No	n/a
Common trouble for telco dialer	No	Acct 1	No	373
Date	No	Acct 1	No	625
Dialer disable/remote disconnect	Yes	Acct 1	No	n/a
Dialer line 1 fault (disable)	Yes	None	No	n/a
Dialer line 1 fault (trouble)	Yes	Acct 1	No	351
Dialer line 2 fault (disable)	Yes	None	No	n/a
Dialer line 2 fault (trouble)	Yes	Acct 1	No	352
Dialer deliver fail	Yes	Acct 1	No	354
Dialer normal test	No	Acct 1	No	602
Dialer abnormal test	No	Acct 1	No	608
Dialer configuration	Yes	None	No	n/a
Drill	Yes	None	No	n/a
Internal fault	Yes	Acct 1	No	307
IP gateway trouble	Yes	None	Yes	n/a
Local AC power (disable)	Yes	None	No	n/a
Local AC power (trouble)	Yes	None	No	n/a
Net rcvr conf fault	Yes	Acct 1	No	354
Net comm fault (1-8) (disable)	Yes	None	No	500
Net comm fault (1-8) (trouble)	Yes	Acct 1	No	354
Outputs are latched	Yes	None	No	n/a
Panel silence	No	None	No	315
Program mode	Yes	Acct 1	No	627
Reset	Yes	Acct 1	No	305
Reset/Silence inhibit	No	None	No	n/a
Self test fault	Yes	None	No	n/a
Signal silence	Yes	None	No	n/a

Panel event	Printer	Dialer	NET (1-8)	CID
System ground fault (disable)	Yes	None	No	n/a
System ground fault (trouble)	Yes	Acct 1	No	310
System startup	Yes	None	No	n/a
System wide AC power (disable)	Yes	None	No	n/a
System wide AC power (trouble)	No	Acct 1	No	301
Test fire	No	None	No	n/a
Time	No	Acct 1	No	625
Walk test	Yes	Acct 1	No	607
DHCP Communication Fault	Yes	Acct 1	No	354
DNS Communication Fault	Yes	Acct 1	No	354
Net Receiver 1 Primary Communication Trouble	Yes	Acct 1	No	354
Net Receiver 2 Primary Communication Trouble	Yes	Acct 1	No	354
Net Receiver 3 Primary Communication Trouble	Yes	Acct 1	No	354
Net Receiver 4 Primary Communication Trouble	Yes	Acct 1	No	354
Net Receiver 5 Primary Communication Trouble	Yes	Acct 1	No	354
Net Receiver 6 Primary Communication Trouble	Yes	Acct 1	No	354
Net Receiver 7 Primary Communication Trouble	Yes	Acct 1	No	354
Net Receiver 8 Primary Communication Trouble	Yes	Acct 1	No	354
Net Receiver 1 Secondary Communication Trouble	Yes	Acct 1	No	354
Net Receiver 2 Secondary Communication Trouble	Yes	Acct 1	No	354
Net Receiver 3 Secondary Communication Trouble	Yes	Acct 1	No	354
Net Receiver 4 Secondary Communication Trouble	Yes	Acct 1	No	354
Net Receiver 5 Secondary Communication Trouble	Yes	Acct 1	No	354
Net Receiver 6 Secondary Communication Trouble	Yes	Acct 1	No	354
Net Receiver 7 Secondary Communication Trouble	Yes	Acct 1	No	354
Net Receiver 8 Secondary Communication Trouble	Yes	Acct 1	No	354
IP Dialer Account 1 Normal Test	No	Acct 1	Yes	602
IP Dialer Account 2 Normal Test	No	Acct 1	Yes	602
IP Dialer Account 3 Normal Test	No	Acct 1	Yes	602
IP Dialer Account 4 Normal Test	No	Acct 1	Yes	602
IP Dialer Account 5 Normal Test	No	Acct 1	Yes	602
IP Dialer Account 6 Normal Test	No	Acct 1	Yes	602

Panel event	Printer	Dialer	NET (1-8)	CID
IP Dialer Account 7 Normal Test	No	Acct 1	Yes	602
IP Dialer Account 8 Normal Test	No	Acct 1	Yes	602
IP Dialer Account 1 Abnormal Test	No	Acct 1	Yes	608
IP Dialer Account 2 Abnormal Test	No	Acct 1	Yes	608
IP Dialer Account 3 Abnormal Test	No	Acct 1	Yes	608
IP Dialer Account 4 Abnormal Test	No	Acct 1	Yes	608
IP Dialer Account 5 Abnormal Test	No	Acct 1	Yes	608
IP Dialer Account 6 Abnormal Test	No	Acct 1	Yes	608
IP Dialer Account 7 Abnormal Test	No	Acct 1	Yes	608
IP Dialer Account 8 Abnormal Test	No	Acct 1	Yes	608

Table 40: List of non-restoring events

Panel event	CID
Test fire	n/a
Clear history	621
Panel silence	315
Set time	625
Set date	625
Dialer Normal Test	602
Dialer Abnormal test	608
IP Dialer Account 1 Surgard Normal Test	602
IP Dialer Account 2 Surgard Normal Test	602
IP Dialer Account 3 Surgard Normal Test	602
IP Dialer Account 4 Surgard Normal Test	602
IP Dialer Account 5 Surgard Normal Test	602
IP Dialer Account 6 Surgard Normal Test	602
IP Dialer Account 7 Surgard Normal Test	602
IP Dialer Account 8 Surgard Normal Test	602
IP Dialer Account 1 Surgard Abnormal Test	608
IP Dialer Account 2 Surgard Abnormal Test	608
IP Dialer Account 3 Surgard Abnormal Test	608
IP Dialer Account 4 Surgard Abnormal Test	608
IP Dialer Account 5 Surgard Abnormal Test	608
IP Dialer Account 6 Surgard Abnormal Test	608

Panel event	CID
IP Dialer Account 7 Surgard Abnormal Test	608
IP Dialer Account 8 Surgard Abnormal Test	608

To program panel events:

1. Press the Menu button and choose Program.
2. Choose Advanced Program.
3. Enter a level two password.
4. Choose Panel Events.
5. Select the event to be programmed.
6. Choose Event Notification.
7. Configure the event notification options. See the default settings in the table above. Not all options shown here are displayed on all systems.

Printer: Yes or No. This controls whether event information is sent to the printer

Dialer:

- Acct 1 & 2: Event information is sent to both dialer accounts
- Acct 1: Event information is sent to dialer account one
- Acct 2: Event information is sent to dialer account two
- None: Event information is not sent to the dialer

CID: Contact ID event code (000 to 999)

Network: Controls whether event information is sent to the connected network

8. When you have finished configuring each page, choose Save.
9. Repeat steps 6 to 9 for each panel event.
10. Press the Menu button to exit menu mode, or continue programming.

Loop event programming

Loop events, such as loop fault, and loop initialization have an event notification setting for contact ID, dialer, NET (1-8), and printer, which controls where the event is sent when it takes place. Each event has a factory default setting that can be used with no additional programming.

Table 41: Default loop event settings

Loop event	Printer	Dialer	NET (1-8)	CID
Loop 1 initialization	Yes	None	No	n/a
Loop 1 fault (disable)	Yes	None	No	n/a

Loop event	Printer	Dialer	NET (1-8)	CID
Loop 1 fault (trouble)	Yes	Acct 1	No	331
Loop 1 card fault (disable) (e.g., line fault)	Yes	None	No	n/a
Loop 1 card fault (trouble) (e.g., line fault)	Yes	Acct 1	No	333
Loop 1 Uncfgrd alarm (disable)	Yes	None	No	n/a
Loop 1 Uncfgrd alarm (trouble)	Yes	Acct 1	No	110
Loop 1 Uncfgrd trbl (disable)	Yes	None	No	n/a
Loop 1 Uncfgrd trbl (trouble)	No	None	No	n/a
Loop 1 over limits	Yes	None	No	n/a
Loop 1 address zero	Yes	None	No	n/a
Loop 2 initialization	Yes	None	No	000
Loop 2 fault (disable)	Yes	None	No	500
Loop 2 fault (trouble)	Yes	Acct 1	Yes	331
Loop 2 card fault (disable) (e.g., line fault)	Yes	None	No	500
Loop 2 card fault (trouble) (e.g., line fault)	Yes	Acct 1	No	333
Loop 2 Uncfgrd alarm (disable)	Yes	None	No	500
Loop 2 Uncfgrd alarm (trouble)	Yes	Acct 1	No	110
Loop 2 Uncfgrd trbl (disable)	Yes	None	No	500
Loop 2 Uncfgrd trbl (trouble)	No	None	No	331
Loop 2 over limits	Yes	None	No	331
Loop 2 address zero	Yes	None	No	331
Loop 3 initialization	Yes	None	No	000
Loop 3 fault (disable)	Yes	None	No	500
Loop 3 fault (trouble)	Yes	Acct 1	Yes	331
Loop 3 card fault (disable) (e.g., line fault)	Yes	None	No	500
Loop 3 card fault (trouble) (e.g., line fault)	Yes	Acct 1	No	333
Loop 3 Uncfgrd alarm (disable)	Yes	None	No	500
Loop 3 Uncfgrd alarm (trouble)	Yes	Acct 1	No	110
Loop 3 Uncfgrd trbl (disable)	Yes	None	No	500
Loop 3 Uncfgrd trbl (trouble)	No	None	No	331
Loop 3 over limits	Yes	None	No	331
Loop 3 address zero	Yes	None	No	331
Loop 4 initialization	Yes	None	No	000
Loop 4 fault (disable)	Yes	None	No	500
Loop 4 fault (trouble)	Yes	Acct 1	Yes	331

Loop event	Printer	Dialer	NET (1-8)	CID
Loop 4 card fault (disable) (e.g., line fault)	Yes	None	No	500
Loop 4 card fault (trouble) (e.g., line fault)	Yes	Acct 1	No	333
Loop 4 Uncfgrd alarm (disable)	Yes	None	No	500
Loop 4 Uncfgrd alarm (trouble)	Yes	Acct 1	No	110
Loop 4 Uncfgrd trbl (disable)	Yes	None	No	500
Loop 4 Uncfgrd trbl (trouble)	No	None	No	331
Loop 4 over limits	Yes	None	No	331
Loop 4 address zero	Yes	None	No	331

To program loop events:

1. Press the Menu button and choose Programming.
2. Choose Advanced Program and enter the level 2 password.
3. Choose Loop Events.
4. Select the loop event.
5. Choose Event Notification.
6. Set the event notification. See the default settings in the table above.

Printer: Yes or No. Specifies if event information is printed.

Dialer:

- Acct 1 & 2: Event information is sent to both dialer accounts
- Acct 1: Event information is sent to dialer account one
- Acct 2: Event information is sent to dialer account two
- None: Event information is not sent to the dialer

NET (1-8): Yes or No. Specifies if event information is sent to the connected network

CID: Contact ID event code (000 to 999)

7. When finished, choose Save.
8. Repeat steps 6 to 9 for each loop event.
9. Press the Menu button to exit menu mode, or continue programming.

Unconfigured alarm event programming

You can assign the unconfigured alarm event to a correlation group and use it to turn on an output device. When assigned to a correlation group, every unconfigured alarm event turns on every output device in the correlation group. You can also program the event notification CID

code for the unconfigured alarm. Auto programming will not assign an unconfigured alarm to a correlation group.

To program the unconfigured alarm event:

1. Press the Menu button and choose Programming.
2. Choose Advanced Program and enter the level 2 password.
3. Choose Unconfigured Alarm.
4. Choose the desired Loop Uncfgd Alarm. (Loops 2 through 4 options are displayed only if you have more than one loop).
5. Choose Correlation Groups and enter the number of the correlation group.
6. Press Enter to toggle between possible values:
To add the event to the group, choose Included.
— or —
To remove it from the group, choose Excluded.
7. Repeat steps 7 to 9 to add or remove the event from any remaining correlation groups to be configured.
8. Choose Save.
9. Choose Event Notification.
10. Choose Active.
11. Configure active event notification. (Not all the options shown here are displayed on all systems.)
Printer: This controls whether event information is sent to the printer. Press Enter to toggle between Yes and No.
Coder: Four-digit coded output that is played in response to alarm conditions (00-00-00-00 to 99-99-99-99).
Dialer options are listed below.
 - Acct 1 & 2: Event information is sent to both dialer accounts
 - Acct 1: Event information is sent to dialer account one
 - Acct 2: Event information is sent to dialer account two
 - None: Event information is not sent to the dialer.CID: Contact ID event code (000 to 999).
NET (1-8): Yes or No. This controls whether event information is sent to the connected network.
12. When you have finished, choose Save.
13. Press the Menu button to exit menu mode, or continue programming.

Common trouble event programming

The common trouble event can be assigned to a correlation group and turn on an output device. When the common trouble is assigned to a correlation group, every output device in the correlation group turns on. Event notification can also be programmed for the common trouble.

Notes

- Every trouble event turns on the output devices in the correlation group it is assigned to, so make sure you are not assigning the common trouble to an output group that turns on devices that you do not want to turn on (e.g., NACs).
- If you assigned a NAC and the common trouble event to a correlation group and the NAC goes into trouble, when the NAC trouble clears the NAC outputs *do not* turn off even though the common trouble condition cleared because the NACs are not supervised. To turn off the NAC outputs, you must manually restore the NAC from the front panel's Control menu option.

To program the common trouble event:

1. Press the Menu button and choose Programming.
2. Choose Advanced Program and enter the level 2 password.
3. Choose Common Trouble.
4. Choose Trouble.
5. Choose Correlation Groups.
6. Enter the correlation group number to be programmed. (Values range from 001 to 199.).
7. Select Yes to add the common trouble to the correlation group or No to not add the common trouble to the correlation group.
8. Repeat steps 8 and 9 until the common trouble is added or removed from each correlation group needed.
9. Choose Save.
10. Choose Event Notification.
11. Choose Trouble.
12. Set trouble event notification.

Printer: Yes or No. This controls whether event information is sent to the printer

Coder:

- Enter the four-digit coded output that is played in response to alarm conditions if a bell coder is installed. Values range from 00-00-00-00 to 99-99-99-99

Dialer:

- Acct 1 & 2: Event information is sent to both dialer accounts
- Acct 1: Event information is sent to dialer account one

- Acct 2: Event information is sent to dialer account two
- None: Event information is not sent to the dialer
- NET (1-8): Yes or No. Controls whether event information is sent to the connected network
- CID: Contact ID event code (000 to 999)

13. When you have finished, choose Save.

14. Press the Menu button to exit menu mode, or continue programming.

Chapter 3

System operation

Summary

This chapter covers the front panel display, operating the panel, and controlling devices, NACs, and zones.

Content

- Operation overview 135
 - Front panel display 135
 - Control panel operations 135
- LCD display screen 136
 - System normal display screen 136
 - System off-normal display screen 137
 - Event details display screens 138
- System LEDs 140
- LED display expander LEDs 141
- Control buttons 142
 - Common control buttons 142
 - Buttons for working with menus and entering text 143
 - Programmable buttons (Key 1 and Key 2) 145
 - Programmable button function priority 146
- Component descriptions 147
- Events with event messages 148
 - Event printout examples 149
- Event ID numbers and descriptions 151
- Viewing event details 156
- Resetting the panel 157
- Silencing panel and annunciator buzzers 158
- Silencing notification appliances 158
 - Silencing NACs manually 158
 - Silencing NACs automatically 159
 - NACs that cannot be silenced 159
- Conducting a lamp test 159

Activating and restoring output devices	160
Unlatching latched output devices	160
Activating and restoring panel NACs	161
Activating and restoring sensor bypass	162
Activating and restoring gas accelerated response	163
Disabling and enabling devices	165
Disabling and enabling zones	166
Disabling and enabling panel events	167
Disabling and enabling loop events	168
Disabling and enabling panel NACs	170
Disabling and enabling the dialer and network	170
Initiating a fire drill	171
Conducting a walk test	171

Operation overview

Front panel display

The front panel display is the user interface for the control panel. The display is comprised of the LCD, LED indicators, and control buttons that are used to operate and program the panel.

Figure 48: Front panel display layout

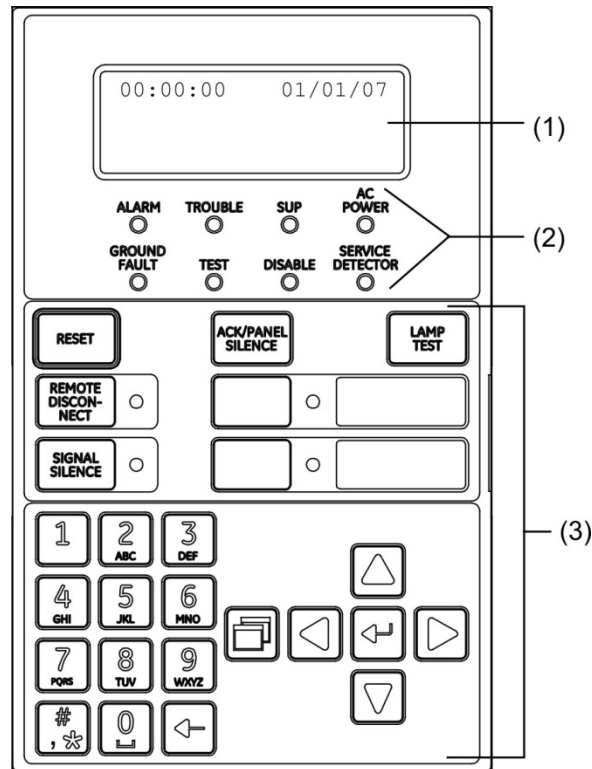

(1) LCD display
(2) System LEDs

(3) Control buttons

Control panel operations

The control panel operates in either normal mode or off-normal mode.

Normal mode

The panel operates in normal mode in the absence of any alarm, supervisory, trouble, or monitor events. In normal mode, the control panel monitors the system. The panel and LCD remote annunciators display the time, date, and banner text, if programmed.

Off-normal mode

The panel operates in off-normal mode any time an event is introduced into the system. When this happens, the panel:

- Changes contact positions on appropriate common relays
- Activates alarm outputs (for alarm events only)
- Turns on the appropriate LEDs and the panel buzzer
- Executes the appropriate programmed output response for the input that signaled the event
- Communicates event information to the LCD display and the remote annunciator
- Sends a record of the event to the remote annunciator and to the control panel's history log
- Transmits event messages to a central monitoring station as programmed
- Prints event information on the printer if one is connected to the panel

LCD display screen

The liquid crystal display (LCD) is a 4-line by 20-character display that provides the user interface with the control panel for system programming, testing, report viewing, and off-normal event notification. The LCD has a backlight that turns on when a button is pushed or when an alarm event takes place in the system. When the panel is operating on battery power, the backlight automatically turns off after one minute of inactivity.

System normal display screen

The LCD shows the system normal display screen when the control panel is in the normal (quiescent) state. The screen displays the following:

- Time: Displays the current time.
- Date: Displays the current date in month/day/year format.
- Login: When you are logged on, the LCD shows "login:" and the password level in the top-right of the display, alternating with the date and other information being displayed in that area of the screen (e.g., reset).
- Banner area: Nothing is displayed in this area unless a custom banner has been added. See "Panel operation programming" on page 120.

Figure 49: LCD under normal conditions

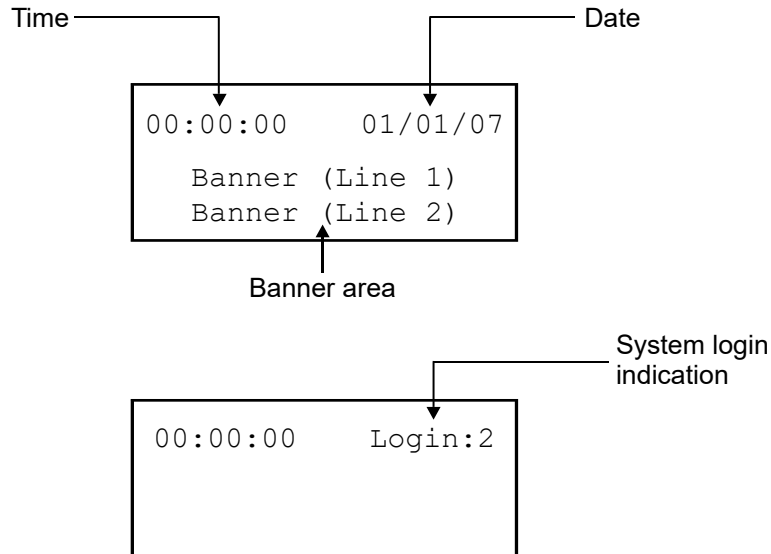

System off-normal display screen

During an off-normal event, such as an alarm, supervisory, monitor, trouble, prealarm, alarm verify, disablement, or test, the LCD screen changes to display important information about the event. The screen displays the following:

- Time: Displays the current time.
- Active points: Indicates the number of active points in the system. Increments or decrements as devices activate and restore. If you are logged on, this information toggles with “login.”
- Disabled points: Indicates the number of disabled points in the system. If you are logged on, this information toggles with “login.”
- Event number: The event number for the active event currently displayed in the queue.
- Event type message: The event message for the type of event taking place. Example: Alarm, Active, Waterflow, Trouble, Supervisory, or Monitor.
- Device label: The label for the device, either the default label (Loop ## Device ###) or a custom programmed label with up to forty characters.

Figure 50: LCD under off-normal conditions

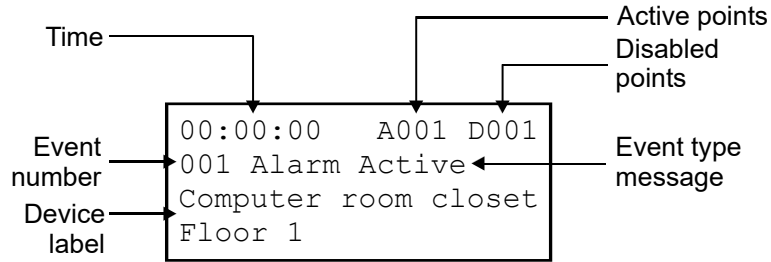

Event details display screens

The off-normal events that take place in the system contain event information that is displayed on the LCD screen. Additional information is available on a secondary screen. The screen displays the following information based on the type of event that takes place:

- Loop number: The loop the device is on
- Device number: The device address (number)
- Device type: The device type that was assigned in programming
- Internal event number: See “Event ID numbers and descriptions” on page 151
- Zone number and device label for devices in zones
- Annunciator number and label
- Other information when it is available

Figure 51: Device event details display screen

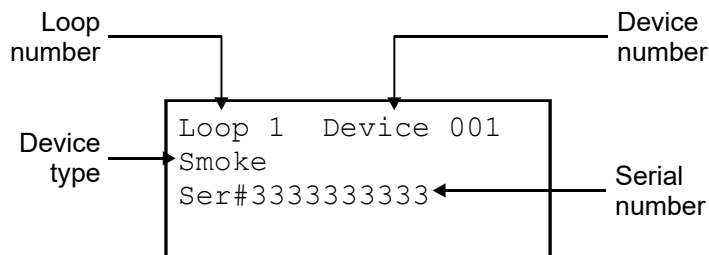
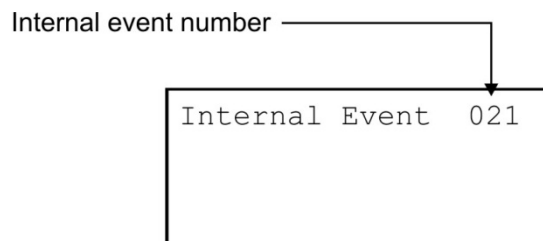
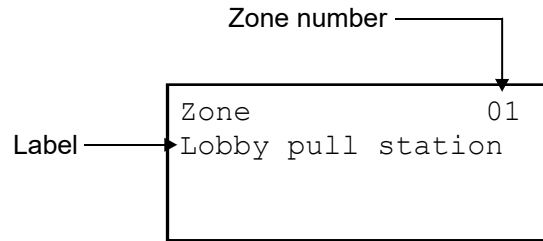

Figure 52: Internal event (panel and loop events) details display screen



Note: See “Event ID numbers and descriptions” on page 151 for a list of event numbers.

Figure 53: Zone event details display screen

Note: You can scroll through the list of all devices in the zone reporting an event:

- Navigate to the desired active zone using the up arrow or down arrow buttons.
- When at the desired active zone, press the enter button to view active devices inside the zone.
- Once inside the zone, press the down arrow button to see each active device within that zone.

Figure 54: Annunciator event details display screen

To view event details:

1. When an event takes place, press Enter on the front panel.
2. View the event details.

The event details screen is displayed for 15 seconds and then returns to the previous screen if there is no activity.

System LEDs

LEDs indicate system events and system operation.

Table 42: System LEDs

LED	Description
Alarm	Red LED. Flashes when there is an active alarm event on any loop. On steady once acknowledged.
Trouble	Yellow LED. Flashes when there's a fault with a monitored circuit or system component or when a circuit is disabled. On steady once acknowledged.
Sup (Supervisory)	Yellow LED. Flashes when there is an active supervisory event on any loop. On steady once acknowledged.
AC Power	Green LED. On when the panel has AC power.
Disable	Yellow LED. On steady when there is a disabled circuit or alarm relay.
Ground Fault	Yellow LED. On steady during an active ground fault.
Test	Yellow LED. Steady when performing an audible walk test. Flashing indicates a silent test.
Service Detector	<p>Yellow LED. Indicates that detector needs servicing. Six months before the detector goes end of life, the panel posts a device maintenance alert and the Service Detector LED goes on steady.</p> <p>When the detector reaches end of life, the detector goes into trouble and the panel posts a device trouble alert. The Service Detector LED goes off, and the Trouble LED flashes.</p>
Signal Silence	Yellow LED. On steady indicates that NAC circuits are turned off but the panel is still in alarm.
Remote Disconnect	Yellow LED. On steady indicates that the CMS devices (dialer and network card) are disabled or that the alarm relay is enabled or disabled when the dialer is set to modem only.
User keys	Yellow LED. Indicates that the programmed key function is active.

LED display expander LEDs

Note: For use with FX-1000 panels, only.

The D16L-Fa LED Display Expander provides LED annunciation for up to 16 zones. The expander provides two LEDs for each zone. You can install two D16L-FA LED display expanders in the FX-1000 panel.

LED operation zones 1 through 12

(Also applies to zones 17 through 28 if the second LED expander is installed.)

- LED 1 - Alarm: Red LED flashes
- LED 2 - Trouble: Yellow LED flashes

LED operation zones 13 through 16

(Also applies to zones 29 through 32, if the second LED expander is installed.)

- LED 1 - Bicolor
Alarm: Red LED flashes
Non-alarm (Monitor/Supervisory) active: Yellow LED flashes
- LED 2 - Trouble: Yellow LED flashes

For CAN/ULC-S527 compliant installations, CO detectors with a CO alarm device type must be programmed using zones with bicolor LEDs (zones 13 through 16 (16 zone expander) and 29 through 32 (32 zone expander)) and the zone type must be set to Supervisory. The panel Event Notification must be set to Zone. Using this configuration ensures that when the “CO alarm” device type goes active, the panel displays a yellow LED indication instead of a red.

Figure 55: LED zone designations

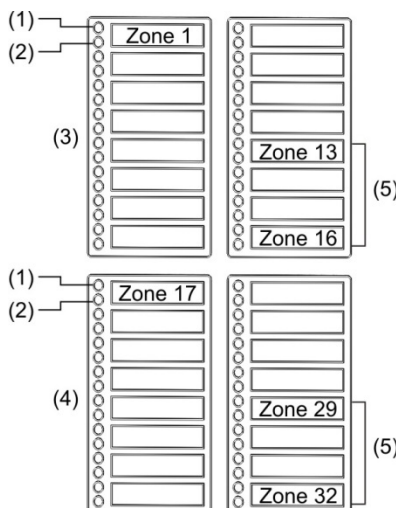

- (1) LED 1
- (2) LED 2
- (3) LED expander 1
- (4) LED expander 2
- (5) Alarm/non-alarm and trouble zone LEDs

Control buttons

Common control buttons

Common control buttons on the front panel perform a variety of functions. Table 44 below identifies the common controls and describes their functions.

Table 43: Common controls

Button	Description
Remote Disconnect	<p>CMS devices (dialer and network card): Disables or enables the dialer and network CMS connection and purges all pending event transmission to the CMS. Has no effect on the alarm relay.</p> <p>Dialer set to modem only (and no network card CMS configured): Disables or enables the common alarm relay.</p> <p>Systems with a panel or device NAC configured as city tie: Disables or enables the city tie NACs.</p> <p>The button LED indicates that the function is active.</p> <p>Note: A minimum of a level one password is required to operate.</p>
Lamp Test	<p>Press the Lamp Test button to initiate a panel lamp test. This lets you verify proper operation of the LEDs on the panel and the remote annunciators.</p>
Reset	<p>Initiates a system reset.</p>
ACK/Panel Silence	<p>Silences the panel and annunciator sounders during an active trouble, supervisory, or alarm event and acknowledges new event activations.</p>
Signal Silence	<p>Silences notification appliances activated by an alarm condition. Pressing Signal Silence a second time turns NACs back on. The button LED indicates when the panel is in alarm and operating with notification appliances turned off. Visual and audible appliances may or may not turn off when Signal Silence is pressed depending on panel programming.</p>
Drill	<p>Initiates a drill when the button is pressed for two seconds. The button LED indicates the function is active.</p> <p>Pressing drill a second time turns off the drill function.</p> <p>Note: Drill will not operate with an active alarm or supervisory event at the panel.</p>

Buttons for working with menus and entering text

Table 45 below describes the menu command buttons and the buttons on the alphanumeric keyboard.

Use the alphanumeric keypad to enter passwords, create text labels, and enter device and group numbers. Values appear on the LCD screen as you press the button.

Note: You can use each number button to enter multiple values. For example, use the “2” button to enter either the number “2” or the letters “A,” “B,” “C,” or “a,” “b,” “c.”





To enter text, numbers, or symbols:





1. Press the button once to enter the number, or press again to scroll through the alternate values. Wait for the cursor to move to the next position.
2. Enter the next number, character, or symbol.

Note: To select an alternate case, continue to press the key until the letter shows in the desired case. The following letters appear in the same case.

3. When you have finished, press the Enter button.

Table 44: Buttons for working with menus and entering text

Button	Description
Menu 	Opens and exits menu mode. Menu mode allows you see the report, test, control, program, and diagnostic options.
Left Arrow 	Moves the cursor to the left (when the panel is in display mode) Scrolls through the available values for a programming option (when the panel is in menu mode)
Right Arrow 	Moves the cursor to the right (when the panel is in display mode) Opens a submenu or scrolls through available values for a programming option (when the panel is in menu mode)
Up Arrow 	Scrolls back to the previous event (when the panel is in display mode) Moves the cursor up (when the panel is in menu mode)

Button	Description
Down Arrow	<p>Scrolls forward to the next event (when the panel is in display mode)</p> <p>Moves the cursor down (when the panel is in menu mode)</p>
	
Enter	<p>Displays detailed information about the selected event (when the panel is in display mode)</p> <p>Opens a submenu or jumps to the Save function in the menu so you can quickly save your changes (when the panel is in menu mode)</p> <p>Enters the selected data into the system (when you are entering data)</p>
	
Cancel	<p>Returns to the previous screen</p> <p>Erases the previous character (when you are entering data)</p> <p>Exits the detailed information display and returns to the event list (when the panel is in display mode)</p> <p>Returns to the previous menu level or (if you are at the highest menu level) exits menu mode</p> <p>Clears the current entry and moves the cursor to the left (when you are entering data)</p> <p>Exits entry mode and returns to menu mode (if the cursor is at the leftmost position)</p>
	
Space	<p>Enters the number “0” (when pressed once)</p> <p>Enters a space (when pressed twice)</p>
	
Symbol	<p>Enters the symbol “#” (when pressed once)</p> <p>Enter the “*” symbol (when pressed twice)</p> <p>Enters a comma (when pressed three times)</p>
	

Note: When the line on the LCD displays “>”, “<”, or “<>” as its last character, use the arrow keys to make your selection; otherwise, use the Enter key.

Programmable buttons (Key #1 and Key #2)

You can program the two unlabeled control buttons on the front panel to operate the LCD and perform the functions listed in Table 46 below. Operating the buttons requires a level 2 password. Label the buttons for their function using the slip-in label.

Table 45: Functions available for programmable buttons (Key #1 and Key #2)

Function	Description
Activate	<p>The first press turns on outputs in any number of correlation groups. The button LED turns on.</p> <p>The second press turns off these same outputs and the button LED.</p>
Disable	<p>The first press disables any number of correlation groups, correlation group members, or both. The button LED turns on.</p> <p>The second press enables the same set of correlation groups and correlation group members and turns off the button LED.</p> <p>The Disable function operates differently based on the whether you choose Correlation Groups, Members of Correlation Group, or Both. The default value is Members.</p> <ul style="list-style-type: none"> • If you choose Disable Correlation Group: <ul style="list-style-type: none"> An LCD message indicates that Corr Grp xxx is disabled All outputs (including relay and sounder bases) are turned off and the disabled correlation group stops operating Note: Detector bases that are configured to be activated by their attached detector cannot be disabled through group disable operation. • If you choose Members of Correlation Group: <ul style="list-style-type: none"> An LCD message identifies the Disabled members. Disabling members of a correlation group does not disable relay or sounder bases. Active devices cannot be enabled through a programmable button. To enable these devices, press the Menu button and choose Control>Enable Device. • If you choose Both: <ul style="list-style-type: none"> The correlation group stops operating and all members are disabled. An LCD message identifies the Disabled members.
Unlatch	Unlatches all latched outputs system-wide.
Restore	Restores outputs in any number of correlation groups to their normal state. (Disabled or latched devices must be enabled or unlatched before they can be restored.)
None	Removes any function associated with the button.

Alarm ON	<p>Used for manual evacuation in the Canadian Marketplace. Pressing the Alarm ON button places the control panel in the alarm condition, activates all drillable outputs which include all notification appliance circuits and all sounder bases, signals the central station with CID 115. The panel still responds to initiating device circuits that are activated while sounding a manual evacuation. The Alarm ON event is restored upon panel reset. If Alarm ON is initiated while reset is in progress, the event will be restored at the end of reset.</p> <p>To meet CAN/ULC-S527 requirements, User Key 1 default is Alarm ON when the Canadian marketplace is selected.</p>
----------	---

Programmable button function priority

- Operations such as Signal Silence, Auto Signal Silence, and Drill take priority over Activate, Restore, and Disable.
- Activate, Restore, and Disable take priority over in-suite signal silence.
- A single Restore or Disable takes priority over one or more Activates.
- Restore or Group Disable only affects devices from correlation groups that have been added to the list for that button.
- Although an Activate button can turn on both latched and unlatched devices, it can only turn off unlatched devices. Latched outputs remain active until you press a button programmed for Unlatch. Until the output has been unlatched, the panel displays an “Outputs are Latched” monitor event message.
- The Disable and Restore commands do not affect active latched outputs until after the Unlatch button has been pressed. Until the output has been unlatched, the panel displays an “Outputs are Latched” monitor event message.

Component descriptions

The control panel contains the following components.

Figure 56: Component layout

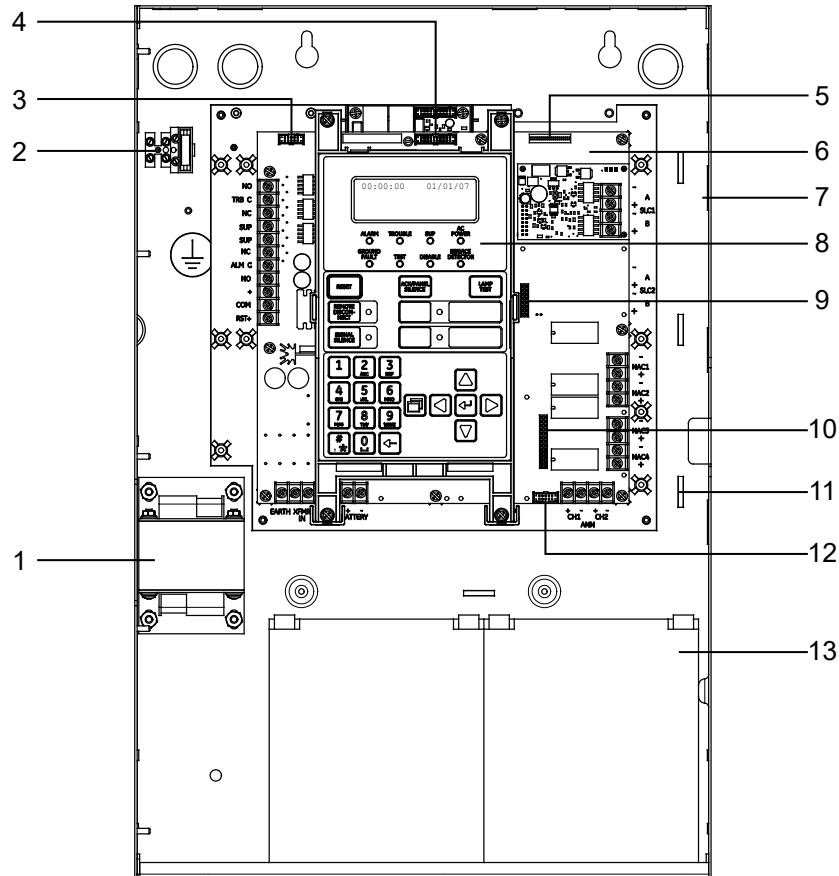

Item	Description
1	Transformer: Changes 120 or 230 volt AC supply voltage to 24 volt AC.
2	Main AC wiring block and fuse holder: Provides connections for 120 or 230 volt AC (primary power) from dedicated service. Includes a primary power fuse (5 A).
3	RS-232 card connector (J3): Provides a connection for the optional RS-232 card for connecting a printer or downloading from the configuration utility.
4	Dialer card connection (J8): Provides a connection for the optional dialer card.
5	Ethernet card connector (J1): Provides a connection for the optional Ethernet card.
6	Main circuit board: Provides connections for all circuits. Also includes the operator interface.
7	Panel backbox enclosure: Houses the panel electronics and standby batteries. In some cases, the batteries may be housed in an external battery cabinet (BC-1).
8	Operator interface: Includes operator controls, LED indicators, and control buttons

Item	Description
9	SLC card connector (J7): Provides a connection for an additional SLC card (only on the FX-1000 panel)
10	Class A card connector (J2): Provides a connection for the optional Class A card (only on the FX-64 panel)
11	Tie wrap mounts: Used to secure wires and to help maintain proper separation between power-limited and nonpower-limited conductors
12	LED expander connector (J6): Provides a connection for the optional LED expander
13	Standby batteries: Provide secondary/standby power to the panel electronics in the absence of primary power

Events with event messages

Table 46: Events with event messages

Event type		LCD	Printer [1]
Alarm	Active type reporting		
	Input smoke	Alarm active	SMK ACT
	Input smoke verified	Alarm active	SMK ACT
	Input heat	Heat alarm	HEAT ACT
	Input heat rate of rise	Heat alarm	HEAT ACT
	Input duct alarm	Alarm active	DUCT ACT
	Input pull station	Pull station alarm	PULL ACT
	Input waterflow	Waterflow	WFLW ACT
	Input waterflow retard	Waterflow	WFLW ACT
	CO alarm	Gas CO active	COAL ACT
	Zone alarm	Alarm active	ALRM ACT
	Zone waterflow	Alarm active	ALRM ACT
	Alarm ON	Alarm active	ALRM ACT
	Supervisory type reporting		
	Input duct alarm	Supervisory	DUCT ACT
	CO supervisory	Gas CO active	COSU ACT
	Zone supervisory	Supervisory	SUPV ACT
	Input supervisory latching	Supervisory	SUPV ACT
	Input supervisory nonlatching	Supervisory	SUPV ACT

Event type		LCD	Printer [1]
	Monitor type reporting		
	CO monitor	Gas CO active	COMO ACT
	Zone monitor	Monitor	MON ACT
	Input monitor	Monitor	MON ACT
	Outputs are latched	Outputs are latched	Outputs are latched
	Prealarm reporting	Prealarm	PALM ACT
	Alarm verify reporting	Alarm verify	ALMV ACT
	Maintenance alert reporting	Maint. alert	MANT ACT
Trouble	All devices	Trouble	TRBL ACT
Disable	All devices	Disable	DSBL ACT
Test	All devices	Test	TEST ACT

[1] See “Event printout examples” below for an example of how events appear when printed.

Event printout examples

Event information is printed each time an event takes place provided a printer is connected to the system. The following is an example of what the event information looks like on the printout and a description of each piece of information printed for an event.

Annunciator event

```
TRBL ACT | 18:00:07 01/01/2007      A:008
Annunciator 08
```

Where:

TRBL ACT = Trouble event

18:00:07 01/01/2007 = Time and date the event took place

A:008 = Annunciator 08

Annunciator 08 = Label (could be the default label or a custom label)

Internal event (panel or loop event)

```
MON ACT | 18:00:18 01/01/2007      E:010
Loop 2 Initializing
```

Where:

MON ACT = Monitor event

18:00:18 01/01/2007 = Time and date the event took place

E:010 = Event 010 (see “Event ID numbers and descriptions” on page 151)

Loop 2 initializing = Label (could be the default label or a custom label)

Zone event

ALRM ACT | 18:00:34 01/01/2007 Z:008
Zone 08

Where:

ALRM ACT = Alarm event

18:00:34 01/01/2007 = Time and date the event took place

Z:008 = Zone 08

Zone 08 = Label (could be the default label or a custom label)

Device event

ALRM ACT | 18:00:34 01/01/2007 L:1 D:124
Loop 1 Device 124

Where:

ALRM ACT = Alarm event

18:00:34 01/01/2007 = Time and date the event took place

L:1 = Loop 1

D:124 = Device 124

Loop 1 Device 124 = Label (could be the default label or a custom label)

Event ID numbers and descriptions

Table 47: Event ID numbers and descriptions

ID	Event description	ID	Event description
000	Loop 1 initialization: Loop 1 is starting up	016	Loop 2 map mismatch: The loop 2 map in RAM and the loop 2 map in the database do not match
001	Loop 1 fault: A short or open was detected on loop 1 affecting the communications between the panel and the devices on the loop	017	Loop 2 over limits: There are too many devices on loop 2
002	Loop 1 map fault: A mapping fault was detected on loop 1 while the panel was mapping the devices	018	Loop 2 device 000: A device on loop 2 has an address set to zero
003	Loop 1 card fault: The loop 1 card is not present or it is not working properly	019	Loop 2 mapping: Loop 2 is mapping devices
004	Loop 1 uncfgd alarm: A device on loop 1 that is not programmed went into alarm	020	Loop 3 initialization: Loop 3 is starting up
005	Loop 1 uncfgd trouble: A device on loop 1 that is not programmed went into trouble	021	Loop 3 fault: A short or open was detected on loop 3 affecting the communications between the panel and the devices on the loop
006	Loop 1 map mismatch: The loop 1 map in RAM and the loop 1 map in the database do not match	022	Loop 3 map fault: A mapping fault was detected on loop 3 while the panel was mapping the devices
007	Loop 1 over limits: There are too many devices on loop 1	023	Loop 3 card fault: The loop 3 card is not present or it is not working properly
008	Loop 1 device 000: A device on loop 1 has an address set to zero	024	Loop 3 uncfgd alarm: A device on loop 3 that is not programmed went into alarm
009	Loop 1 mapping: Loop 1 is mapping devices	025	Loop 3 uncfgd trouble: A device on loop 3 that is not programmed went into trouble
010	Loop 2 initialization: Loop 2 is starting up	026	Loop 3 map mismatch: The loop 1 map in RAM and the loop 3 map in the database do not match
011	Loop 2 fault: A short or open was detected on loop 2 affecting the communications between the panel and the devices on the loop	027	Loop 3 over limits: There are too many devices on loop 3
012	Loop 2 map fault: A mapping fault was detected on loop 2 while the panel was mapping the devices	028	Loop 3 device 000: A device on loop 3 has an address set to zero
013	Loop 2 card fault: The loop 2 card is not present or it is not working properly	029	Loop 3 mapping: Loop 3 is mapping devices
014	Loop 2 uncfgd alarm: A device on loop 2 that is not programmed went into alarm	030	Loop 4 initialization: Loop 4 is starting up
015	Loop 2 uncfgd trouble: A device on loop 2 that is not programmed went into trouble	031	Loop 4 fault: A short or open was detected on loop 4 affecting the communications between the panel and the devices on the loop

ID	Event description
032	Loop 4 map fault: A mapping fault was detected on loop 4 while the panel was mapping the devices
033	Loop 4 card fault: The loop 4 card is not present or it is not working properly
034	Loop 4 uncfgd alarm: A device on loop 4 that is not programmed went into alarm
035	Loop 4 uncfgd trouble: A device on loop 4 that is not programmed went into trouble
036	Loop 4 map mismatch: The loop 4 map in RAM and the loop 4 map in the database do not match
037	Loop 4 over limits: There are too many devices on loop 4
038	Loop 4 device 000: A device on loop 4 has an address set to zero
039	Loop 4 mapping: Loop 4 is mapping devices
040	System startup: The control panel is starting up
041	Program mode: The control panel is in program mode
042	Reset: The control panel is resetting
043	Reset/Sil inhibit: Reset/silence inhibit is activated
044	Panel silence: The control panel buzzer was silenced
045	Signal silence: The control panel NACs have been silenced
046	Drill: The control panel is in the drill state
047	Walk test: The control panel is in the walk test state
048	Test fire: A smoke or heat detector is being tested
049	Clear history: The control panel's event history was cleared
050	Time: The control panel's time was modified
051	Date: The control panel's date was modified

ID	Event description
052	Common disable: A disable event is taking place on the control panel
053	Common trouble: A trouble event is taking place on the control panel
054	Ground fault: The panel detected a ground fault
055	Battery charger: The panel detected a battery charger trouble condition. The charger may not be able to charge the batteries.
056	Battery low: The batteries are low on charge
057	Battery missing: The battery is no longer connected
058	AC power: There is a problem with the panel's AC power
059	Aux. power 1: The control panel detected a trouble condition on the continuous AUX power circuit 1
060	Aux. power 2: The control panel detected a trouble condition on the resettable AUX power circuit 2
061	System AC power: There is a problem with the panel's AC power and/or a remote auxiliary/booster's AC power
062	Common alarm: An alarm event is taking place on the control panel
063	Common supervisory: A supervisory event is taking place on the control panel
064	Common monitor: A monitor event is taking place on the control panel
065	Common trouble for telco dialer: A trouble event, other than a DACT delivery fault is taking place on the control panel
066	Common trouble for network dialer: A trouble event, including a DACT delivery fault is taking place on the control panel
067	Outputs Are Latched: Outputs in the system are in latched condition
068	Alarm ON: The control panel is in the manual evacuation state.

ID	Event description
069	Self test fault: A fault was detected while testing the panel's internal subsystems (memory, flash, code, etc.)
070	Internal fault: The control panel detected an internal hardware or software error
071	Dialer dsbl/rem disc: The dialer was disabled by the Remote Disconnect button
072	Dialer line 1 fault: A ground fault or line fault was detected on line 1 of the dialer
073	Dialer line 2 fault: A ground fault or line fault was detected on line 2 of the dialer
074	Dialer delivery fail: The dialer failed to deliver a message to the receiver or CMS Note: If the Dialer is configured as dual line, the delivery fault is representative of both the lines and shall be reported only when delivery via both lines fail. If delivery via one line has failed and successful via the other, no faults shall be reported on the panel.
075	Dialer normal test: A dialer test was conducted when the panel was in a normal state
076	Dialer abnormal test: A dialer test was conducted when the panel was in an off-normal state
077	Dialer configuration: The dialer is not programmed or has unverified changes
078	Net Receiver 1 Primary Communication Trouble: Communications between the panel and network receiver 01 failed
079	Net Receiver 2 Primary Communication Trouble: Communications between the panel and network receiver 02 failed
080	Net Receiver 3 Primary Communication Trouble: Communications between the panel and network receiver 03 failed
081	Net Receiver 4 Primary Communication Trouble: Communications between the panel and network receiver 04 failed
082	Net Receiver 5 Primary Communication Trouble: Communications between the panel and network receiver 05 failed

ID	Event description
083	Net Receiver 6 Primary Communication Trouble: Communications between the panel and network receiver 06 failed
084	Net Receiver 7 Primary Communication Trouble: Communications between the panel and network receiver 07 failed
085	Net Receiver 8 Primary Communication Trouble: Communications between the panel and network receiver 08 failed
086	Net Conf Fault 01: The panel failed to communicate with the network receiver 01 after a configuration change
087	Net Conf Fault 02: The panel failed to communicate with the network receiver 02 after a configuration change
088	Net Conf Fault 03: The panel failed to communicate with network receiver 03 after a configuration change
089	Net Conf Fault 04: The panel failed to communicate with network receiver 04 after a configuration change
090	Net Conf Fault 05: The panel failed to communicate with network receiver 05 after a configuration change
091	Net Conf Fault 06: The panel failed to communicate with network receiver 06 after a configuration change
092	Net Conf Fault 07: The panel failed to communicate with network receiver 07 after a configuration change
093	Net Conf Fault 08: The panel failed to communicate with network receiver 08 after a configuration change
094	IPGateway Trouble: IP Gateway configuration is invalid
095	DHCP CommunicationFault: Panel fails to communicate with DHCP server
096	DNS Communication Fault: Panel fails to communicate with DNS server
097	Net Receiver 1 Secondary Communication Trouble: Communications between the panel and network receiver 01 failed

ID	Event description
098	Net Receiver 2 Secondary Communication Trouble: Communications between the panel and network receiver 02 failed
099	Net Receiver 3 Secondary Communication Trouble: Communications between the panel and network receiver 03 failed
100	Net Receiver 4 Secondary Communication Trouble: Communications between the panel and network receiver 04 failed
101	Net Receiver 5 Secondary Communication Trouble: Communications between the panel and network receiver 05 failed
102	Net Receiver 6 Secondary Communication Trouble: Communications between the panel and network receiver 06 failed
103	Net Receiver 7 Secondary Communication Trouble: Communications between the panel and network receiver 07 failed
104	Net Receiver 8 Secondary Communication Trouble: Communications between the panel and network receiver 08 failed
105	IP Dialer Account 1 Normal Test: A Sur-Gard test was conducted when the panel was in a normal state
106	IP Dialer Account 2 Normal Test: A Sur-Gard test was conducted when the panel was in a normal state
107	IP Dialer Account 3 Normal Test: A Sur-Gard test was conducted when the panel was in a normal state
108	IP Dialer Account 4 Normal Test: A Sur-Gard test was conducted when the panel was in a normal state
109	IP Dialer Account 5 Normal Test: A Sur-Gard test was conducted when the panel was in a normal state
110	IP Dialer Account 6 Normal Test: A Sur-Gard test was conducted when the panel was in a normal state
111	IP Dialer Account 7 Normal Test: A Sur-Gard test was conducted when the panel was in a normal state

ID	Event description
112	IP Dialer Account 8 Normal Test: A Sur-Gard test was conducted when the panel was in a normal state
113	IP Dialer Account 1 Abnormal Test: A Sur-Gard test was conducted when the panel was in an off-normal state
114	IP Dialer Account 2 Abnormal Test: A Sur-Gard test was conducted when the panel was in an off-normal state
115	IP Dialer Account 3 Abnormal Test: A Sur-Gard test was conducted when the panel was in an off-normal state
116	IP Dialer Account 4 Abnormal Test: A Sur-Gard test was conducted when the panel was in an off-normal state
117	IP Dialer Account 5 Abnormal Test: A Sur-Gard test was conducted when the panel was in an off-normal state
118	IP Dialer Account 6 Abnormal Test: A Sur-Gard test was conducted when the panel was in an off-normal state
119	IP Dialer Account 7 Abnormal Test: A Sur-Gard test was conducted when the panel was in an off-normal state
120	IP Dialer Account 8 Abnormal Test: A Sur-Gard test was conducted when the panel was in an off-normal state
121	Fw Dwnld in Progress: Firmware update is successfully initiated from the panel and firmware update utility
122	Fw Download Aborted: Firmware update is aborted due to connectivity loss (or) user has aborted download from either panel or update utility
123	Fw Download Failed: Firmware update failed to store the Image.bin into panel flash memory
124	Fw Download Complettd: Firmware update is successfully completed
125	Cloud Provision Fault: The Cloud Provision Fault occurs when the Panel Fails to Register with the Cloud

ID	Event description
126	Cloud Communication Fault: The Cloud Communication Fault occurs when the Panel Fails to communicate with Cloud
127	Panel Certificate Fault: The Panel Certificate Fault occurs when there is no security Certificate on the panel
128	NAC 1 trouble: An open or short was detected on NAC 1 or there is a problem with the EOL
129	NAC 2 trouble: An open or short was detected on NAC 2 or there is a problem with the EOL
130	NAC 3 trouble: An open or short was detected on NAC 3 or there is a problem with the EOL
131	NAC 4 trouble: An open or short was detected on NAC 4 or there is a problem with the EOL
132	Printer trouble: The printer is either offline, out of paper, or disconnected
133	Annunciator 1 trouble: An open or short was detected on annunciator 1
134	Annunciator 2 trouble: An open or short was detected on annunciator 2
135	Annunciator 3 trouble: An open or short was detected on annunciator 3
136	Annunciator 4 trouble: An open or short was detected on annunciator 4
137	Annunciator 5 trouble: An open or short was detected on annunciator 5
138	Annunciator 6 trouble: An open or short was detected on annunciator 6
139	Annunciator 7 trouble: An open or short was detected on annunciator 7
140	Annunciator 8 trouble: An open or short was detected on annunciator 8
141	Zone 1 (active, trouble, disable, prealarm, alarm verify, maintenance alert, or test was detected in zone1)

ID	Event description
142	Zone 2 (active, trouble, disable, prealarm, alarm verify, maintenance alert, or test was detected on zone 2)
143	Zone 3 (active, trouble, disable, prealarm, alarm verify, maintenance alert, or test was detected in zone 3)
144	Zone 4 (active, trouble, disable, prealarm, alarm verify, maintenance alert, or test was detected in zone 4)
145	Zone 5 (active, trouble, disable, prealarm, alarm verify, maintenance alert, or test was detected in zone 5)
146	Zone 6 (active, trouble, disable, prealarm, alarm verify, maintenance alert, or test was detected in zone 6)
147	Zone 7 (active, trouble, disable, prealarm, alarm verify, maintenance alert, or test was detected in zone 7)
148	Zone 8 (active, trouble, disable, prealarm, alarm verify, maintenance alert, or test was detected in zone 8)
149	Zone 9 (active, trouble, disable, prealarm, alarm verify, maintenance alert, or test was detected in zone 9)
150	Zone 10 (active, trouble, disable, prealarm, alarm verify, maintenance alert, or test was detected in zone 10)
151	Zone 11 (active, trouble, disable, prealarm, alarm verify, maintenance alert, or test was detected in zone 11)
152	Zone 12 (active, trouble, disable, prealarm, alarm verify, maintenance alert, or test was detected in zone 12)
153	Zone 13 (active, trouble, disable, prealarm, alarm verify, maintenance alert, or test was detected in zone 13)
154	Zone 14 (active, trouble, disable, prealarm, alarm verify, maintenance alert, or test was detected in zone 14)
155	Zone 15 (active, trouble, disable, prealarm, alarm verify, maintenance alert, or test was detected in zone 15)

ID	Event description	ID	Event description
156	Zone 16 (active, trouble, disable, prealarm, alarm verify, maintenance alert, or test was detected in zone 16)	165	Zone 25 (active, trouble, disable, prealarm, alarm verify, maintenance alert, or test was detected in zone 25)
157	Zone 17 (active, trouble, disable, prealarm, alarm verify, maintenance alert, or test was detected in zone 17)	166	Zone 26 (active, trouble, disable, prealarm, alarm verify, maintenance alert, or test was detected in zone 26)
158	Zone 18 (active, trouble, disable, prealarm, alarm verify, maintenance alert, or test was detected in zone 18)	167	Zone 27 (active, trouble, disable, prealarm, alarm verify, maintenance alert, or test was detected in zone 27)
159	Zone 19 (active, trouble, disable, prealarm, alarm verify, maintenance alert, or test was detected in zone 19)	168	Zone 28 (active, trouble, disable, prealarm, alarm verify, maintenance alert, or test was detected in zone 28)
160	Zone 20 (active, trouble, disable, prealarm, alarm verify, maintenance alert, or test was detected in zone 20)	169	Zone 29 (active, trouble, disable, prealarm, alarm verify, maintenance alert, or test was detected in zone 29)
161	Zone 21 (active, trouble, disable, prealarm, alarm verify, maintenance alert, or test was detected in zone 21)	170	Zone 30 (active, trouble, disable, prealarm, alarm verify, maintenance alert, or test was detected in zone 30)
162	Zone 22 (active, trouble, disable, prealarm, alarm verify, maintenance alert, or test was detected in zone 22)	171	Zone 31 (active, trouble, disable, prealarm, alarm verify, maintenance alert, or test was detected in zone 31)
163	Zone 23 (active, trouble, disable, prealarm, alarm verify, maintenance alert, or test was detected in zone 23)	172	Zone 32 (active, trouble, disable, prealarm, alarm verify, maintenance alert, or test was detected on zone 32)
164	Zone 24 (active, trouble, disable, prealarm, alarm verify, maintenance alert, or test was detected in zone 24)	173 371	CorrGrp nnn: Correlation group nnn is disabled through User key which is configured as Disable (Group/Both) Note: nnn represents the correlation group number (001 to 199).

Viewing event details

The off-normal events that take place in the system contain event information that is displayed on the LCD screen. Additional information is available on a secondary screen called the Event Details screen.

To display the event details screen:

1. When an event takes place, press Enter on the front panel.
2. View the event details.

For a description of the information displayed on the screen, see “LCD display screen” on page 136. The event details screen is displayed for 15 seconds if there is no activity and then returns to the previous screen.

Note: Use the up and down arrow keys to scroll through multiple events.

Resetting the panel

Pressing Reset restores the fire alarm system to the normal state provided that there are no active devices or circuits. The Reset command does not restore disabled or latched devices. Disabled devices must be enabled and latched output devices must be unlatched before they can be restored.

Latched devices are restored when they are unlatched, provided the alarm that triggered the output no longer exists. However, when a user tries to restore the unlatched outputs via the user key or control menu, the output is restored regardless of the alarm condition. Also, when signal silence inhibit or reset inhibit is enabled, the system will not restore until the silence or reset inhibit period lapses.

WARNING: To avoid possible injury or loss of life, do not reset the fire alarm system until the appropriate authority determines that it is safe to do so.

To reset the panel:

1. Press the Reset button.

When you reset the panel:

- “Reset” displays on the top-right of the LCD, alternating with the active and disabled points display.
- Devices in an off-normal state remain in their off-normal state until the element causing their off-normal state clears.
- When the reset process is complete, “Reset” clears from the LCD and the Reset LED turns off.
- If the condition causing an “Alarm Active” condition has not cleared (smoke is still present in detector chamber, pull station was not reset, etc.) the panel remains in an alarm state after resetting and the NACs and other outputs do not reactivate.
- Disabled devices and zones remain disabled after the panel is reset.
- Resetting the panel does not log off user level one or user level two access.

Silencing panel and annunciator buzzers

The panel buzzer sounds whenever an event message is received at the control panel. Pressing the Ack/Panel Silence button:

- Silences the buzzer on the control panel and all remote annunciators.
- Acknowledges all current event messages.
- Silences the panel buzzer on all remote annunciators. If more than one event is queued, the LCD displays event 001.

To silence the buzzer:

1. Determine what event caused the buzzer to sound by pressing Enter to view the event details. This displays the loop number, device address, and a detailed description of the event type
2. Press the Ack/Panel Silence button on the panel, or the Ack/Silence button on any remote annunciator.

Silencing notification appliances

WARNING: Do not silence notification appliances until the building is fully evacuated and the cause of the alarm has been determined.

To silence or resound notification appliances:

1. Press the Signal Silence button.

Silencing NACs manually

Pressing the Signal Silence button turns off all silenceable NACs unless activated by a waterflow device or waterflow zone. Depending on system programming, some audible or visible notification appliances may not turn off when the Signal Silence button is pressed. If a signal silence inhibit was programmed, then pressing the Signal Silence button will not work until the reset inhibit timer expires. See “What is in-suite signal silence?” on page 41.

When you silence the signals:

- The Signal Silence LED lights to indicate that the notification appliances are off.
- If Genesis horn/strobe or horn-only devices are used on NACs programmed for Genesis operation, Signal Silence silences the horns and strobes based on system programming. Pressing Signal Silence a second time while the panel is in an alarm state causes the signals to turn on again.

Silencing NACs automatically

Two options let you silence NACs automatically: Auto Signal Silence and Suite Signal Silence (in-suite signal silence). Both work by starting a timer when an event activates the NACs. The NACs are allowed to sound until the timer expires, after which they are automatically silenced.

The Auto Signal Silence option

Auto Signal Silence can be enabled when programming the panel. It affects all silenceable NACs connected to the panel. The elapsed time can be set for 5 to 30 minutes. See “Activating and restoring sensor bypass” on page 162.

The Suite Signal Silence option

The Suite Signal Silence option enables or disables in-suite signal silence for the selected correlation group. This option affects only silenceable NACs associated with the correlation groups. For more information on this programming option, see “Programming in-suite signal silence” on page 90.

NACs that cannot be silenced

NACs configured as latched outputs cannot be silenced. This includes any device configured as:

- Continuous Non-Silenceable Latched (Cont NS Latch)
- Supervised Outputs Latched (SupOut Latch)
- Continuous Non-Silenceable Class A Latched (Cont NS CIA Latch)
- Supervised Outputs Class A Latched (SupOut CIA Latch)

In addition, NACs activated by devices programmed as waterflow cannot be silenced until the activated devices are restored to normal via a panel reset. After the waterflow device events restore, the Signal Silence button or the auto signal silence timer can silence the NACs if there are other events causing the NACs to activate. Waterflow activations do not invoke in-suite signal silence.

Conducting a lamp test

A lamp test lights all of the LEDs on the panel and the LED annunciator and tests the LCD so that you can verify proper operation. LEDs stay on for 15 seconds.

To conduct a lamp test:

1. Press the Lamp Test button on the front panel.
2. Verify that the LCD, all LEDs on the panel, and LED annunciators (if used) work properly.

Notes

- Pressing the Lamp Test button does not perform a lamp test on remote annunciators. To perform a lamp test on remote annunciators, press the Lamp Test button on the remote annunciator.
- You can also initiate a lamp test from the test menu.

Activating and restoring output devices

Activating an output device on a signaling line circuit (SLC) turns on its output. This is typically done to test individual strobes, horns, and other notification appliances. Restoring the device turns it off again.

Notes

- Input devices cannot be activated. If you attempt to activate an input device, the message “Invalid device” is displayed.
- Disabled devices must be manually enabled and then restored. See “Activating and restoring sensor bypass” on page 162.
- Latched outputs must be manually unlatched and then restored. See “Unlatching latched output device” below.

To activate or restore an output device:

1. Press the Menu button and choose Control.
2. Enter a level one password.
3. Choose Activate/Restore.
4. Choose Device.
5. Choose the loop the device is on.

Note: If the panel only has one loop, the loop selection screen does not display.

6. Enter the device ID for the device that you want to activate or restore.
7. Press Enter.
8. Press Cancel to return to the previous menu.

— or —

Press the Menu button to exit menu mode.

Unlatching latched output devices

Latched outputs are devices that are configured to shut down air handlers and dampers automatically when an alarm activates, and to keep them shut down until they are manually unlatched and restored. For this reason, devices configured as latched output devices must be manually unlatched and then restored.

When outputs have been latched, the panel generates an “Outputs are latched” event. The unlatch command affects all latched output devices system-wide. You can assign the Unlatch Outputs command to a programmable key on the front panel or to one of the following modules: FX-IDC1A, FX-IDC1B, or FX-IDC2B.

To unlatch latched output devices:

1. Press the Unlatch Outputs button on the control panel (if programmed).

— or —

Press the Unlatch Outputs module button (if programmed).

Activating and restoring panel NACs

Activating a notification appliance circuit (NAC) turns on its outputs. Restoring the NAC turns them off again. This is typically done for testing purposes.

Note: Disabled NACs must be manually enabled and then restored. See “Activating and restoring sensor bypass” on page 162.

To activate a panel NAC:

1. Press the Menu button and choose Control.
2. Enter a level one password.
3. Choose Activate/Restore.
4. Choose Panel NAC.
5. Select the NAC that you want to activate.
6. Press Enter.
7. Press Cancel to return to the previous menu.

— or —

Press the Menu button to exit menu mode.

Notes

- Disabled devices must be manually enabled and then restored. See “Activating and restoring sensor bypass” on page 162.

- Latched output devices must be manually unlatched and then restored. See “Unlatching latched output device” on page 160.

Activating and restoring sensor bypass

Use the Activate Sensor Bypass option to stop the photoelectric element on the PHD detector from generating supervisory messages on the LCD, while still using the heat element of the same PHD. Sensor Bypass is applicable to PHD devices with device type as “Heat + Smoke Supv Latching,” or “Heat + Smoke Supv Nonlatching,” only.

Use the Restore Sensor Bypass option when both the heat and smoke (photoelectric) elements of the PHD return to normal operation. Activation messages for either condition appear on the LCD.

When Sensor Bypass is activated, the system displays an alarm message only when the heat element activates. For example, when a large event is planned that allows smoking or pyrotechnics in a ballroom that has a PHD detector installed; you may choose to bypass the smoke element to prevent false activations while still using the heat element to detect a fire.

When a device is off-normal and you attempt to activate or restore sensor bypass, the system displays a warning message. When the activate sensor bypass option is applied to a device, the system responds as follows:

- The common trouble LED turns on.
- The LCD displays an event to indicate that the device is bypassed.
- The common Trouble LED flashes and the panel goes into a trouble state.
- The common Trouble relay changes state.
- The active point indicators on the LCD increment.
- Resetting the panel has no effect on sensor bypass activated devices, but removing all power from the panel clears the sensor bypass and restores the device.

To activate sensor bypass:

1. Press the Menu button and choose Control.
2. Enter a level one password.
3. Choose Activate/Restore.
4. Choose Sensor Bypass.
5. Select the device that you want to bypass.
6. Press Enter.
7. Press Cancel to return to the previous menu.

— or —

Press the Menu button to exit menu mode.

Activating and restoring gas accelerated response

Use the Activate Gas Accelerated Response option to turn on the accelerated response mode.

Under normal conditions, it takes approximately four minutes at 400 PPM of CO before a CO detector activates. This mimics the normal absorption rate of CO in the bloodstream. When testing a CO device, you can put the CO detectors in the CO accelerated response mode, which shortens the time to activation to be between four to eight seconds at 400 PPM of CO.

You can activate a gas accelerated response on devices that have a CO sensor. See Table 12 on page 52. Once activated, the gas accelerated response on that device remains active for four hours, unless you manually restore it, or the device returns from a communication fault.

Along with CO, for Optica detectors the smoke can also be tested with an accelerated response.

Note: When adding devices in a zone, the recommended count is 25 devices. In this way the number of timers running within the firmware for tracking the test time is limited to 25, minimizing the load on the system.

To activate a device accelerated response:

1. Press the Menu button and choose Control.
2. Enter a level one password.
3. Choose Activate/Restore.
4. Choose Device Accel Resp.
5. Select the device that you want to accelerate.
6. Press Enter.
7. Press Cancel to return to the previous menu.

— or —

Press the Menu button to exit menu mode.

To activate a zone accelerated response:

1. Press the Menu button and choose Control.
2. Enter a level one password.
3. Choose Activate/Restore.
4. Choose Zone Accel Resp.
5. Select the zone that you want to accelerate.

6. Press Enter.
7. Press Cancel to return to the previous menu.
— or —
Press the Menu button to exit menu mode.

Disabling and enabling devices

Disabling a device does not prevent it from activating, but it does prevent event messages originating at the device from being displayed, printed, or reported off-premises. Devices are typically disabled during maintenance. Remember to enable the device as soon as you have finished working with it.

Note: Disabling the devices will override the sensor bypass.

The Reset command does not restore disabled or latched devices. Disabled devices must be enabled and latched output devices must be unlatched before they can be restored. The Reset command also does not restore sensor bypass devices, which must be enabled.

When a device is disabled:

- When the device you are disabling is active, a warning message displays.
- The common Disable LED turns on.
- The LCD displays an event to indicate that the device is disabled.
- The common Trouble LED flashes and the panel goes into a trouble state.
- The common Trouble relay changes state.
- The disabled and active points indicators on the LCD increment. The event is transmitted off-premises, if programmed to do so.
- Resetting the panel has no effect on disabled devices, but removing all power from the panel clears the disable and enables the device.

To disable or enable a device:

1. Press the Menu button and choose Control.
2. Enter a level one password.
3. Choose Enable/Disable.
4. Choose Device.
5. Choose the loop the device is on.

Note: If the panel only has one loop, the loop selection screen does not display. Go to the next step.

6. Enter the device ID for the device that you want to disable or enable.
7. Press Enter.
8. If the device is active, acknowledge the warning message by selecting Continue to disable the device or Cancel to exit.

The device is disabled and a message indicating that the device is disabled is displayed on the LCD.

9. Press Cancel to return to the previous menu.

— or —

Press the Menu button to exit menu mode.

Disabling and enabling zones

Zones are typically disabled while maintenance is performed to prevent event messages originating from the zone from being displayed, printed, or reported off-premises. Disabling a zone does not prevent activations in the zone. All devices in the zone continue to function normally.

Note: Remember to enable the zone as soon as you have finished working with it. Resetting the panel does not restore disabled zones. These must be manually enabled and then restored.

When you disable a zone:

- The common Disable LED turns on
- On a zone/device system, the LCD displays disabled messages for the zone and all of the devices in the zone
- On a zone only system, the LCD displays a disabled message for the zone
- The common trouble LED flashes and the panel goes into a trouble state
- The common trouble relay changes state
- The disabled and active points indicators on the LCD increment
- If you are using an LED display expander, the zone LEDs blink for the disabled zone
- Resetting the panel has no effect on a disabled zone, but removing all power from the panel enables the zone
- If the zone you are disabling contains devices that are active, a warning message is displayed

To disable or enable a zone:

1. Press the Menu button and choose Control.
2. Enter a level one password.
3. Choose Enable/Disable.
4. Choose Zone.
5. Select the zone that you want to disable or enable.
6. Press Enter.
7. If devices in the zone are active, acknowledge the warning message by selecting Continue to disable the zone or Cancel to exit.

The zone is disabled.

8. Press Cancel to return to the previous menu.

— or —

Press the Menu button to exit menu mode.

Disabling and enabling panel events

Disabling a panel event prevents the messages that are sent when the event occurs from being displayed, printed, or reported off-premises. Events are typically disabled while maintenance is performed. Remember to enable the event as soon as you have finished working.

Not all panel events can be disabled. Panel events that cannot be disabled are labeled as “forbidden.” The following table lists panel events that can be disabled.

Table 48: Panel events that can be disabled

Event	ID
Ground fault	054
Battery charger	055
Battery low	056
Battery missing	057
AC power	058
System AC power	061
Aux. power 1	059
Aux. power 2	060
Dialer line 1 fault	072
Dialer line 2 fault	073
Net Conf Fault 01	086
Net Conf Fault 02	087
Net Conf Fault 03	088
Net Conf Fault 04	089
Net Conf Fault 05	090
Net Conf Fault 06	091
Net Conf Fault 07	092
Net Conf Fault 08	093

To disable or enable a panel event:

1. Press the Menu button and choose Control.
2. Enter a level one password.
3. Choose Enable/Disable.
4. Choose Panel Event.
5. Enter the ID number of the event type to disable or enable.

See “Event ID numbers and descriptions” on page 151 for event descriptions and the list above for the events that can be disabled.

6. Press Enter.
7. Press Cancel to return to the previous menu.

— or —

Press the Menu button to exit menu mode.

When you disable an event:

- The common Disable LED turns on
- The common Trouble LED flashes and the panel goes into a trouble state
- The common Trouble relay changes state
- The disabled and active points indicators on the LCD increment
- The LCD displays a message indicating that the event is disabled.

Disabling and enabling loop events

Disabling a loop event prevents it from being displayed, printed, or reported off premises. This is typically done during maintenance. For example, you might want to disable the Loop 1 unconfigured alarm event, if you are switching out a detector. Remember to enable the event as soon as you have finished working.

When you disable a loop event:

- The common Disable LED turns on
- The common Trouble LED flashes and the panel goes into a trouble state
- The common Trouble relay changes state
- The disabled and active points indicators on the LCD increment.
- The LCD displays a message indicating which loop event is disabled.

Not all events can be disabled. Those that cannot are labeled as “forbidden.” The following table lists events that can be disabled.

Table 49: Loop events that can be disabled

Event	ID
Loop 1 fault	001
Loop 2 fault	011
Loop 3 fault	021
Loop 4 fault	031
Loop 1 card fault	003
Loop 2 card fault	013
Loop 3 card fault	023
Loop 4 card fault	033
Loop 1 unconfigured alarm	004
Loop 2 unconfigured alarm	014
Loop 3 unconfigured alarm	024
Loop 4 unconfigured alarm	034
Loop 1 unconfigured trouble	005
Loop 2 unconfigured trouble	015
Loop 3 unconfigured trouble	025
Loop 4 unconfigured trouble	035

To disable or enable a loop event:

1. Press the Menu button and choose Control.
2. Enter a level one password.
3. Choose Enable/Disable.
4. Choose Loop Event.
5. Select the loop event type that you want to disable or enable.

See “Event ID numbers and descriptions” on page 151 for event descriptions and the list above for the events that can be disabled.

6. Press Enter.
7. Press Cancel to return to the previous menu.

— or —

Press the Menu button to exit menu mode.

Disabling and enabling panel NACs

Disabling a panel NAC prevents activations from being displayed, printed, or reported off premises. This is typically done during maintenance. Remember to enable the NAC as soon as you have finished working.

NACs that have been disabled are not restored when the panel is reset. They must be enabled and then restored.

NACs configured as latched output devices are not restored when the panel is reset. They must be manually unlatched and then restored.

When you disable a panel NAC:

- The common Disable LED turns on
- The LCD displays a message indicating that the NAC is disabled
- The disabled and active points indicators on the LCD increment
- The common Trouble LED flashes and the panel goes into a trouble state
- The common Trouble relay changes state.

To disable or enable a panel NAC:

1. Press the Menu button and choose Control.
2. Enter a level one password.
3. Choose Enable/Disable.
4. Choose Panel NAC.
5. Select the NAC that you want to disable or enable.
6. Press Enter.

The NAC is disabled and a message indicating that the NAC is disabled is displayed on the LCD.

7. Press Cancel to return to the previous menu.

— or —

Press the Menu button to exit menu mode.

Disabling and enabling the dialer and network

Disabling the dialer, network CMS connection, or any panel or device NACs configured as City Tie prevents transmission of events to the central monitoring station (CMS).

When you enable the dialer and network CMS connection:

- The Remote Disconnect LED turns off
- The message “Dialer Dsbl/Rem Disc” on the LCD disappears

- The disabled points indicator on the LCD decrements
- The active points indicator on the LCD decrements

To disable or enable the dialer and network card:

1. Press Remote Disconnect.
2. Enter a level one password.

Initiating a fire drill

Pressing Drill activates all audible and visible notification appliances according to the panel programming, but does not activate the alarm relay.

Note: Drill does not operate when the panel has an active alarm or supervisory event.

To start a fire drill:

1. Press the Menu button and choose Control.
2. Enter a level one password.
3. Choose Drill.

The control panel turns on all notification appliance circuits.

To stop a fire drill:

1. Press the Menu button and choose Control.
2. Choose Drill.

The control panel turns off all notification appliance circuits.

Conducting a walk test

A walk test lets you test individual zones or devices without having to create an actual alarm condition. You can conduct a walk test in silent or audible mode. In silent mode, the audible devices (NACs) do not sound.

Zones should be placed in walk test one at a time. This allows the balance of the system to remain in service. When a device is activated for testing, it remains active throughout the test and does not restore until the walk test is ended. When the walk test is ended, all of the tested devices restore.

Notes

- Walk test does not operate when the panel has an active alarm event.

- Walk test will not start if a Remote AC Fail Trouble or Local AC Power Trouble event is active.
- Walk test affects mainboard NACs only. Any addressable device configured for NAC operation is not included in the walk test.

When you enter walk test mode:

- The Test LED flashes for a silent walk test and is steady for an audible walk test.
- Walk Test is displayed on the LCD. Walk Test is replaced with the device activation message during the period the device is activated while in walk test mode.
- The panel enters a trouble state. There is no fire protection for the zone in walk test. If an unselected zone or device goes into alarm or trouble, all programmed outputs operate as programmed.

Zones and devices behave as follows during walk test:

- For alarm events, the appropriate panel and annunciator LEDs and buzzers turn on. In the audible (NAC) test mode a four-second pulse sounds for NAC types: continuous nonsilenceable, continuous silenceable, Genesis nonsilenceable, Genesis with audible silence only, and Genesis with audible and visible silenceable on the audible devices. A single 3-3-3 cycle sounds for NAC types: temporal nonsilenceable, temporal silenceable, coder basic, coder continuous, coder 120spm, and coder temporal on the audible devices.
- For trouble events, the appropriate LEDs and the buzzers turn on. In the audible (NAC) test mode a two-second pulse sounds on the audible devices.
- For ground fault events, the appropriate LEDs and the buzzers turn on. In the audible (NAC) test mode, a two-second pulse sounds on the audible devices.
- All device activations are latched until the walk test is ended or the panel is reset. When the walk test is ended, it takes approximately eight seconds for the devices to restore. If the device being tested is in a zone and does not restore, the zone does not reset.
- If auxiliary power is resettable, the auxiliary power is interrupted while the zone is reset.
- Input zones programmed as waterflow with retard require 10 to 15 seconds of activation to initiate the test signals.
- Devices programmed as alarm verify and *not in test mode* go directly into alarm if activated (the alarm verification process is bypassed).
- Once a device is tested, restore the device. For example, if you are testing a pull station, reset the pull station before testing the next device.

The panel terminates walk test if:

- The zone or device being tested remains inactive for 30 minutes
- The walk test is stopped by the user

To start a walk test:

1. Press the Menu button and choose Test.
2. Choose Walk Test Silent or Walk Test Audible.
3. Enter a level one password.
4. Choose either All Devices or Zone.
5. If you chose Zone, enter the zone ID for the zone to be tested.
6. Choose Start.
7. Conduct the walk test.
8. Press Cancel to return to the previous menu.

— or —

Press the Menu button to exit menu mode.

Note: To see the activation and restoration of all walk test events, the panel must be reset *prior* to ending the walk test. Once the reset is complete, you can end the walk test and view a walk test report.

To end a walk test:

1. Press the Menu button and choose Test.
2. Choose Walk Test Silent or Walk Test Audible.
3. Choose either All Devices or Zone.
4. If you chose Zone, enter the zone ID of the zone where you are ending the walk test.
5. Choose End to turn off the walk test. All of the devices that were activated in the test are restored at this time.
6. Press Cancel to return to the previous menu.

— or —

Press the Menu button to exit menu mode.

Chapter 4

Reports

Summary

This chapter describes how to create the panel's available reports.

Content

Basic steps for viewing and printing reports 176

History report 176

Walk Test report 177

Device Maintenance report 178

System Status report 178

Correlation Groups report 179

Correlation Group Configuration report 179

Zone report 180

System Configuration report 180

Internal Status report 181

Device Details report 181

Diagnostics reports 181

Internal Fault report 183

Canceling a report 183

Basic steps for viewing and printing reports

To view or print a report:

1. Press the Menu button and choose Reports.
2. Select the report that you want to run.
3. Supply values for the options requested.
4. Choose either:

LCD: The report is displayed on the LCD.

— or —

Printer: The report is printed on the connected printer. If you do not have a printer, this option is not available.

5. If you selected LCD, press Cancel twice to return to the reports menu, when you have finished viewing the report.
6. Choose another report to view.

— or —

Press the Menu button to exit menu mode.

Notes

- You must have a printer connected to the panel to print a report.
- Requesting a report while another report is being printed or displayed on the LCD stops the current report (even if it has not finished) and starts the new report that you requested.

History report

The panel maintains latest 1,000 system or user events in non-volatile memory. The event record contains the event time, the event type, the event state, and the device address (for device events). The event time is the time and date of the event activation or restoration. The event types are alarm, trouble, supervisory, monitor, and test activations or disable. The event state is either activation or restoration. The device address is the address for the device that caused the event. Some events do not have a device address listed, such as the type of events listed in the “Event ID numbers and descriptions” topic on page 151. These are “pseudo” type events. History reports can be viewed on the LCD or printed.

Note: Common Trouble NetWK and Common Trouble TELCO active/restore events will display in the history report whenever there is a “Common trouble” event activated/restored.

There are three types of history reports you can generate:

- All: Includes all events in the report
- Alarm: Includes only alarm events in the report
- Date forward: Lets you enter a starting date for the report. The report includes all events from that date forward.

To view an All or Alarm History report:

1. Press the Menu button and choose Reports.
2. Choose History.
3. Choose either All or Alarm.

To view a Date Forward History report:

1. Press the Menu button and choose Reports.
2. Choose History.
3. Choose Date Forward.
4. Enter the starting date for the report (month/day/year).

Walk Test report

The Walk Test report extracts all test events for the last walk test stored in history. Walk test reports can be printed or viewed on the LCD.

Notes

- You cannot view a walk test report while conducting a walk test.
- The walk test report includes all events (walk test and all other events) to show whether other events occurred during the walk test.
- The walk test report cannot be viewed from history after restarting the panel.
- To include the activation and restoration of all walk test events in the walk test report, the panel must be reset *prior* to ending the walk test. Once the reset is complete, you can end the walk test and view a walk test report.

To view a Walk Test report:

1. Press the Menu button and choose Reports.
2. Choose Walk Test.

Device Maintenance report

The panel provides a Device Maintenance report of all detectors in the system. The report can include: all detectors, all detectors over 20% dirty, or all detectors over 80% dirty. The report displays the device, along with its dirty percentage and sensitivity setting. Device Maintenance reports can be printed or viewed on the LCD.

Note: On an unconfigured system with a full load of CO devices, after the system has been configured, it takes approximately 1.5 hours to retrieve the CO running days data from all devices. For subsequent restarts, without reprogramming, the delay in reporting the running days is less than 5 minutes.

To view a Device Maintenance report:

1. Press the menu button and choose Reports.
2. Choose Device Maintenance.
3. Choose one of the following:
 - All Devices
 - Devices \geq 20% Dirty
 - Devices \geq 80% Dirty.

Note: COD, HCD, PCD, and PHCD detectors have a lifespan of ten years. They report the number of months left until end of life on the LCD and in maintenance reports. When a CO detector has less than six months until EOL, the LCD displays a maintenance alert. When the months until EOL reach zero, the LCD restores the maintenance alert and issues an EOL trouble for the device. For combination detectors, the system detects and reports the percent dirty separate from the CO number of months until EOL.

System Status report

The panel provides a System Status report for all active points in the system. The report can include: all active points, all alarm points, all supervisory points, all trouble points, all disabled points, or all other points. System status reports can be printed or viewed on the LCD.

To view a System Status report:

1. Press the Menu button and choose Reports.
2. Choose System Status.

3. Choose one of the following:

- All
- Alarm
- Supervisory
- Trouble
- Disable
- Other

Correlation Groups report

The panel provides a report for each correlation group in the system. The Correlation Group report shows all of the devices, zones, and NACs that are assigned to a correlation group. Correlation group reports can be printed or viewed on the LCD.

To view a Correlation Groups report:

1. Press the Menu button and choose Reports.
2. Choose Correlation Groups.
3. Enter the number of the correlation group for which you want a report.

Correlation Group Configuration report

The Correlation Group Configuration report lists:

- All correlation groups with in-suite signal silence enabled.
— or —
- All correlation groups with an activation count greater than 1. This provides information on correlation groups programmed for special applications.

To view a Correlation Group Configuration report:

1. Press the menu button and choose Reports.
2. Choose Corr Group Config.
3. Choose one of the following:
 - Suite Sig Sil
 - Activation Count
 - or —
 - Delay

Zone report

The panel provides a Zone report that lists all of the devices that are in a selected zone. The report lists the devices by the device label.

To view a zone report:

1. Press the Menu button and choose Reports.
2. Choose Zone.
3. Choose the zone for which you want a report.

System Configuration report

The panel provides a System Configuration report that displays the current configuration of the system. There are seven system configuration reports displaying the information shown below. System configuration reports can be printed or viewed on the LCD.

All report: Displays all panel, device, loop, zone, event, and dialer configuration information.

Panel operation report: Displays firmware version, marketplace, language, AC fail delay, reset inhibit, zone re-sound, auto signal silence, in suite silence time, port CU, key #1, key #2, aux power reset, lock remote read, AC voltage, date format, daylight savings, minutes offset, day start, night start, LCD banner, IP (IP address), MSK (subnet mask), and GWY (gateway), and event notification type configuration information.

Panel configuration report: Displays dialer, network, printer, annunciator class, annunciator, and NAC configuration information.

Devices report: Displays function, type, zone, label, follow, day sensitivity, night sensitivity, day pre-alarm percent, night pre-alarm percent, correlation groups, and event notification configuration information.

Loop/zone configuration report: Displays loop class, zone, device, and correlation group configuration information.

Event configuration report: Displays loop event and panel event configuration information.

Dialer configuration report: Displays central monitoring station event notification settings for the points in the system.

To view a System Configuration report:

1. Press the Menu button and choose Reports.
2. Choose System Configuration.

3. Choose:

- All
- Panel Operation
- Panel Configuration
- Loop/Zone Config
- Devices
- Event Config
- Dialer Config

Internal Status report

The panel provides an Internal Status report that displays the current values for AC voltage, battery voltage, and battery charge current. Internal Status reports can be printed or viewed on the LCD.

To view an Internal System Status report:

1. Press the Menu button and choose Reports.
2. Choose Internal Status.

Device Details report

A Device Details report displays a device count that reports how many devices are connected to the system.

To view the device count on the system:

1. Press the Menu button and choose Reports.
2. Choose Device Details.
3. Choose Device Count.

Diagnostics reports

There are two Diagnostics reports designed to show the communication performance of the devices on a loop.

Comm Retries report

This report lets you display a list of devices that have required two, three, or four consecutive communication poll retries. It lists the devices that could potentially generate a communication

fault by showing the maximum number of retries for the current hour and a summary of the past 24 hours.

The report can be used to identify devices with intermittent communication faults. A device appearing in this report is an indication that the wiring to the device is suspect. To investigate problem devices, inspect the wiring between the problem device and another device not in the report. Inspect this section of wiring for problems such as loose connections and intermittent wiring breaks.

Note: The current hour retries can be cleared and updated by running the Loop Comm Check diagnostic. (See “Loop comm check” on page 188 for more information.)

Response Quality report

This report lists the devices that are communicating at or below a quality percentage that you specify. By entering different percentages, you can troubleshoot device communications on a loop.

The panel periodically stores the measurement of the response for individual devices during communication polling. The report displays the result of the latest poll as a percentage, where 100% is the best response (maximum possible pulse strength) and anything less than 44% means that the device failed a communication poll and could potentially generate a communication fault.

Devices appearing in this report are an indication that the wiring to the devices is questionable or that the devices themselves are questionable. To investigate problem devices, inspect the wiring between the problem device and another device not in the report. Inspect the wiring for problems such as exceeding wiring specifications (see “Addressable device loop wiring” on page 12 for more information), loose connections, and intermittent wiring breaks and shorts.

To view a Comm Retries diagnostic report:

1. Press the menu button and choose Reports.
2. Choose Diagnostics.
3. Choose Comm Retries.

To view a Response Quality diagnostic report:

1. Press the Menu button and choose Reports.
2. Choose Diagnostics.
3. Choose Response Quality.
4. Enter the quality percentage (0 to 100).

This is a communication percentage value that is used to display the device’s minimum recorded pulse strength percentage. Enter “80” to list devices that are communicating up to 80 percent of their maximum pulse strength. Enter “50” to list devices that are communicating up to 50 percent of their maximum pulse strength (devices communicating better than 50% are not included in the report).

Internal Fault report

The Internal Fault report displays information about an internal fault event (event ID 69) that has occurred in the system. The report contains information that is important for technical support when troubleshooting the internal fault event and should typically only be run when you are asked to do so by a technical support representative.

To view an Internal Fault report:

1. Press the menu button and choose Reports.
2. Choose Int. Fault.

Canceling a report

Once a report is sent to the LCD or printer, you can cancel the report so that it stops printing on the printer or displaying on the LCD.

To cancel a report:

1. Press the Menu button and choose Reports.
2. Choose Cancel Reports.
3. Choose Yes to cancel the report. Choose No to continue with the report.
4. Continue working with reports,

— or —

Press the Menu button to exit menu mode.

Chapter 5

Diagnostics, maintenance, and testing

Summary

This chapter provides diagnostics, preventive maintenance, and testing information.

Content

Preventive maintenance schedule	186
Fast Ground Check	186
Recalibrate device	186
Flash Device LED	187
Loop comm check	187
Control panel testing	188
Canadian tests for grounds, opens, and shorts	189
Electronic testing of a device (test fire)	189
SA-DACT testing	190
Conducting a lamp test	191
Starting and stopping a walk test	191
Using HyperTerminal	193
Replacing a device in alarm	194

Preventive maintenance schedule

Refer to the NFPA 72 section on Inspection, Testing, and Maintenance, the Canadian Electrical Code Part I, CAN/ULC-S524, or CAN/ULC-S536 for more information on required inspection and testing methods and frequencies for fire alarm systems and devices. For detector sensitivity and functionality testing, refer to the detector manufacturer's installation instructions.

Fast Ground Check

Use Fast Ground Check to quickly check the system for ground faults. During normal operation the system checks for ground faults every thirty seconds and reports them by flashing the Ground Fault LED. When you are troubleshooting ground faults on the system, you may not want to wait thirty seconds for the system to perform the ground fault check. Use the Fast Ground Check to decrease the system ground fault check time to every four seconds. The fast ground check will be effective after a time period of thirty seconds since the initiation of the fast ground check. This allows you to troubleshoot your ground faults much quicker and determine if they were actually corrected.

Note: Once you solve the ground faults in the system, turn off the Fast Ground Check. The system automatically turns off the Fast Ground Check after thirty minutes from its start.

To turn on and off Fast Ground Check:

1. Press the menu button and choose Diagnostics.
2. Enter a level two password.
3. Choose Fast Ground Check.
4. Choose Start to turn on Fast Ground Check or choose End to turn off Fast Ground Check.

Recalibrate device

The Recalibrate command resets a detector's environmental compensation and dirtiness level. You can use this command after cleaning to immediately see whether the device was cleaned properly. Allowing the panel to recognize that the device has been cleaned and recalibrate it automatically takes considerably more time. A device trouble will return, indicating that more cleaning is required. If the device is cleaned, the corresponding device trouble will clear.

To recalibrate a device:

1. Press the menu button and choose Diagnostics.
2. Enter a level two password.

3. Choose Recalibrate Device.
4. Choose the loop the device is on.

Note: If the panel only has one loop, the loop selection screen does not display. Go to the next step.

5. Choose the number of the device that you want to recalibrate.
6. Press Enter.

Flash Device LED

Flash Device LED is used to help in troubleshooting to locate a device on a loop by flashing the device's LED (detectors flash red LED, modules flash green LED). For example, if you do not know the location of the device, you can flash the LED for that device address. This will cause the LED to flash, making it easy for you to find the device.

To start and stop flashing a device LED:

1. Press the menu button and choose Diagnostics.
2. Enter a level two password.
3. Choose Flash Device LED.
4. Choose the loop the device is on.

Note: If the panel only has one loop, the loop selection screen does not display. Go to the next step.

5. Choose the number of the device.
6. Choose Start to begin flashing the device LED or choose End to stop flashing the device LED.

Loop comm check

Loop Comm Check is used to determine which loop devices are not communicating. When you run this command, the system checks the device communications on the system's device loops. The devices that are not communicating are listed in a report that you can then use to troubleshoot the problem. Once a report is generated, it remains in memory until another report is generated. This lets you access the latest report in Reports menu > Diagnostics > Loop Comm Check.

To do a loop comm check:

1. Press the Menu button and choose Diagnostics.

2. Enter a level two password.
3. Choose Loop Comm Check.

You can monitor the progress of the check on the Diagnostics screen.

4. Once the check is complete, choose “Continue” to go to the report Diagnostics screen, and then continue with the next step.

— or —

Choose “Back” to return to the Diagnostics menu. If you choose Back, you have to go to the Reports menu > Diagnostics > Loop Comm Check to see the report once the report is created.

Note: This process may take considerable time depending on how large the system is. If it takes longer than four minutes (log on time expiration), the system automatically logs you off if there is no activity. Should this occur, you must log on again and go to the Reports section to view the diagnostic report, once it is generated.

5. Choose Loop Comm Check.
6. Choose either:

LCD: This displays the report on the LCD.

— or —

Printer: The sends the report the printer (if one is connected to the panel). If you do not have a printer, this option is not available.

7. If you selected LCD, press Cancel twice to return to the reports menu, when you have finished viewing the report.
8. Press the Menu button to exit menu mode.

Control panel testing

Before starting, notify all areas where the alarm sounds and off-premises locations that receive alarm and trouble transmissions that testing is in progress.

Records of all testing and maintenance shall be kept as required by the AHJ.

- Required tools:
 - Listed aerosol smoke (photo detectors)
 - Magnehelic gauge (duct detectors)
 - Carbon monoxide test gas (CO detectors)
 - Heat gun (heat detectors)
 - Slotted screwdriver, insulated
 - Digital multimeter
 - 12 in. (30.5 cm) jumper lead with alligator clips

Panel door key
Sound level meter

- A complete check of installed field wiring and devices should be made at regular intervals in accordance with NFPA 72, Canadian Electrical Code Part I, ULC-S524, and ULC-S536 requirements. This includes testing all alarm and supervisory initiating devices and circuits and any off-premises connections.
- Panel operation should be verified in the alarm, supervisory, and trouble modes.
- To ensure that the panel can operate correctly when primary power is lost, the batteries should be inspected and tested periodically. Batteries should be replaced (at a minimum) every four years.

Canadian tests for grounds, opens, and shorts

ULC requires that you test ground fault, open circuit, and short circuit indications.

For ground fault tests, short one leg of the circuit to chassis ground and verify that the system Ground Fault LED and Trouble LEDs turn on.

For NAC open circuit tests, remove the end-of-line resistor from the last device on the circuit and verify that the system Trouble LED turns on.

For NAC short circuit testing, place a short across the NAC output terminals and verify that the system Trouble LED turns on.

For AUX power short circuit testing, place a short across the AUX power output's plus (+) and minus (-) terminals and verify that the system Trouble LED turns on.

For annunciator communications testing, place a short across channel 1 (+ and -) and verify that the system Trouble LED turns on. Repeat for channel 2.

Electronic testing of a device (test fire)

A test fire is a test activation of a smoke or heat detector or input module. A test fire can be conducted to test for proper operation of a detector or input module and its programming. When a detector is test fired, the panel sends a command to the detector at which time the detector simulates a smoke or heat buildup, causing an actual activation of the detector. When an input module is test fired, the panel sends a command to the module causing the module to simulate an activation (alarm, supervisory, or monitor).

Notes

- A test fire is not an equivalent substitute for required functional testing per NFPA 72. In all cases, the manufacturer's documented testing procedures should be followed in accordance with all applicable codes, standards, and methods approved by the AHJ
- NAC responses activate as programmed.

To test fire a device:

1. Press the Menu button and choose Test.
2. Choose Test Fire.
3. Enter a level one password.
4. Choose the loop the device is on.

Note: If the panel only has one loop, the loop selection screen does not display. Go to the next step.

5. Enter the device number of the device you want to test fire.
6. Press Enter.
7. Choose Start to start the test.
8. When you have finished, press Reset (or repeat steps 1 to 7 and choose End) to clear the test alarms and return the system to normal.
9. Press Cancel to return to the previous menu.
— or —
Press the Menu button to exit menu mode.

SA-DACT testing

A dialer test is a test of the telephone line for each dialer account. When a dialer is tested, a normal or abnormal test message (depending on the state of the system) is sent to the selected account. If the dialer is set up for dual line operation, a test message is sent to both lines regardless of the success of the transmission for either account.

Note: Before conducting a test, configure the dialer's accounts for proper operation.

To conduct a dialer test:

1. Press the control panel's Menu button.
2. Choose Test.
3. Choose Dialer.
4. Enter a level one password.
5. Select the account that you want to test.
6. Press Enter.

The test message is sent to the CMS account that you selected. For verification of the CMS account receiving the test message, you must be in contact with the CMS account during the test. Nothing is displayed on the LCD.

7. Press Cancel to return to the previous menu.
— or —
Press the Menu button to exit menu mode.

Conducting a lamp test

A lamp test lights all of the LEDs on the panel and the LED annunciator and tests the LCD so that you can verify proper operation. LEDs stay on for 15 seconds.

To conduct a lamp test:

1. Press the Lamp Test button on the front panel.
2. Verify that the LCD, all LEDs on the panel, and LED annunciators (if used) work properly.

Starting and stopping a walk test

A walk test lets you test individual zones or devices without having to create an actual alarm condition. You can conduct a walk test in silent or audible mode. In silent mode, the audible devices (NACs) do not sound. In audible mode, only the panel onboard NACs activate. Addressable devices configured for use as a NAC are not affected.

Zones should be placed in walk test one at a time. This allows the balance of the system to remain in service. When a device is activated for test, it remains active throughout the test and does not restore until the walk test is ended. When the walk test is ended, all of the tested devices restore.

Note: Walk test does not operate when the panel has an active alarm event.

When you enter walk test mode:

- The Test LED is steady for an audible walk test and flashes for a silent walk test.
- Walk Test is displayed on the LCD. Walk Test is replaced with the device activation message during the period the device is activated while in walk test mode.
- The panel enters a trouble state. There is no fire protection for the zone in walk test. If an unselected zone or device goes into alarm or trouble, all programmed outputs operate as programmed.

Zones and devices behave as follows during walk test.

- For alarm events, the appropriate panel and annunciator LEDs and buzzers turn on. In the audible (NAC) test mode a four-second pulse sounds for NAC types: continuous nonsilenceable, continuous silenceable, Genesis nonsilenceable, Genesis with audible silence only, and Genesis with audible and visible silenceable on the audible devices. A single 3-3 cycle sounds for NAC types: temporal nonsilenceable, temporal silenceable, coder basic, coder continuous, coder 120spm, and coder temporal on the audible devices.
- For trouble events, the appropriate LEDs and the buzzers turn on. In the audible (NAC) test mode a two-second pulse sounds on the audible devices.
- For ground fault events, the appropriate LEDs and the buzzers turn on. In the audible (NAC) test mode, a two-second pulse sounds on the audible devices.

- All device activations are latched until walk test is ended or the panel is reset. When walk test is ended, it takes approximately eight seconds for the devices to restore. If the device being tested is in a zone and does not restore, the zone does not reset.
- If auxiliary power is resettable, the auxiliary power is interrupted while the zone is reset.
- Input zones programmed as waterflow with retard require 10 to 15 seconds of activation to initiate the test signals.
- Devices programmed as alarm verify and *not in test mode* go directly into alarm if activated (the alarm verification process is bypassed).
- Restore each device after testing. For example, if you are testing a pull station, reset the pull station before testing the next device.

The panel terminates walk test if:

- The zone or device being tested remains inactive for 30 minutes.
- The walk test is stopped by the user.

To start a walk test:

1. Press the Menu button and choose Test.
2. Choose Walk Test Silent or Walk Test Audible.
3. Enter a level one password.
4. Choose either All Devices or Zone.
5. If you chose Zone, enter the zone ID for the zone you are going to conduct the walk test.
6. Choose Start.
7. Conduct your walk test.
8. Press Cancel to return to the previous menu.

— or —

Press the Menu button to exit menu mode.

Note: To see the activation and restoration of all walk test events, the panel must be reset *prior* to ending the walk test. Once the reset is complete, you can end the walk test and view a walk test report.

To end a walk test:

1. Press the Menu button and choose Test.
2. Choose Walk Test Silent or Walk Test Audible.
3. Choose either All Devices or Zone.
4. If you chose Zone, enter the zone ID of the zone for which you are going to end the walk test.

5. Choose End to turn off the walk test. All of the devices that were activated in the test are restored at this time.
6. Press Cancel to return to the previous menu.

— or —

Press the Menu button to exit menu mode.

Using HyperTerminal

HyperTerminal is a program that comes with your Windows operating system as an installable option. You can use it to connect to other computers, Telnet sites, bulletin board systems (BBSs), online services, and host computers. HyperTerminal connections are made using a modem, a null modem cable (used to emulate modem communication), or an Ethernet connection. When installed, HyperTerminal is typically found on the Accessories menu (Start > All Programs > Accessories > Communications).

HyperTerminal is a useful tool for gathering information from the control panel through an RS-232 port or USB connection in order to troubleshoot system faults. The information gathered can be saved as a plain text file (TXT extension) and submitted electronically to technical support for evaluation.

Note: To use HyperTerminal, you must have the optional SA-232 or SA-USB Interface Card installed in the control panel. To avoid getting a printer trouble, set the panel's printer option to Unsupervised before connecting your computer to the SA-232 or SA-USB card.

Setting up a HyperTerminal connection

Before you can gather information from the control panel you must set up a HyperTerminal connection.

To set up a HyperTerminal connection:

1. Start HyperTerminal.
2. In the Connection Description dialog box, type a name for the connection in the Name box then click OK.
3. In the Connect To dialog box, select the COM port you are using to connect your laptop computer to the control panel, and then click OK.
4. In the COM port's Properties dialog box, set the port settings as described below, and then click OK.

Bits per second: 9600

Data bits: 8

Parity: None

Stop bits: 1

Flow control: None

5. On the File menu, click Save to save your connection settings.

Capturing a report

The history report provides useful information for troubleshooting system faults. You should always have this information available before calling technical support.

To capture a report:

1. On the Transfer menu, click Capture Text.
2. In the File box in the Capture Text dialog box, type a name for the captured text file. Example: History Report. The TXT file extension is added automatically.

If you want to save the file somewhere other than the default location, click the Browse button, navigate to the desired location, and then name the file.
3. Click Start.
4. On the front panel, go to the main menu, choose Reports, and then choose the report you want captured.
5. On the Print Output menu, choose Printer to send the report to HyperTerminal.
6. Wait until the report transfer is complete.
7. On the Transfer menu, click Capture Text, and then Stop.

Replacing a device in alarm

You can replace a device with a new device of the same type while it is in alarm. You may need to do this when the device is faulty or for troubleshooting purposes. If you replace a device while it is in alarm, the device and control panel operate as follows:

- When the device in alarm is removed, the control panel remains in alarm and a trouble event displays.
- When installed, the new device does not go into alarm, but the LCD displays a second trouble event when the panel detects the new.
- When the control panel resolves the new device, the alarm condition restores and the two trouble events clear from the control panel.

Note: If the device causing the alarm is reinstalled, the device goes into alarm and the alarm condition does not restore.

Appendix A

Panel specifications

Summary

This appendix lists all of the specifications for the control panel.

Content

Control panel specifications 196

Control panel specifications

	FX-64 panel	FX-1000 panel
Device loops	<p>1 loop Class B/DCLB, Class A/DCLA, or Class X/DCLC supporting up to 64 device addresses (any combination of detectors and modules)</p> <p>Maximum T-taps: 63 (each device can be on its own branch)</p>	<p>1 loop, expandable to 4, Class A/DCLA, Class B/DCLB, or Class X/DCLC. Each loop supporting up to 250 device addresses (125 detectors and 125 modules max.). Addresses 1 to 125 are for detectors and addresses 201 to 325 are for modules.</p> <p>Maximum T-taps/loop: 124</p>
Notification appliance circuits	<p>2 Class B, Class A optional</p> <p>3.75 A FWR total at 120/230 VAC 60 Hz</p> <p>3.0 A FWR total at 230 VAC 50 Hz</p> <p>2.5 A FWR each max. per circuit</p>	<p>4 Class B or 2 Class A</p> <p>6.0 A FWR total at 120/230 VAC 60 Hz</p> <p>5.0 A FWR total at 230 VAC 50 Hz</p> <p>2.5 A FWR each max. per circuit</p>
Primary power	<p>120 VAC, 60 Hz, 1.3 A max.</p> <p>230 VAC, 50-60 Hz, 0.62 A max.</p>	<p>120 VAC, 60 Hz, 2.0 A max.</p> <p>230 VAC, 50-60 Hz, 0.97 A max.</p>
Base panel current standby	155 mA	172 mA
Base panel current alarm	204 mA	267 mA
Input zones	16 max.	32 max.
Remote annunciator	<p>8 drops max., RS-485 Class B, Class A is optional</p> <p>Data line length: 4,000 ft. (1,219 m)</p>	<p>8 drops max., RS-485 Class A or B</p> <p>Data line length: 4,000 ft. (1,219 m)</p>
Operating voltage	24 VDC panel	
Auxiliary power output circuit	<p>AUX 1 power: 500 mA (standby), 24 VDC. Up to 1000 mA of alarm current is available on AUX 1 if you reduce the total available control panel NACs alarm current by the amount of AUX 1 + AUX 2 alarm current over 500 mA)</p> <p>AUX 2 power: 500 mA (standby and alarm), 24 VDC (resettable)</p> <p>AUX 1 + AUX 2: Total maximum standby current = 500 mA</p> <p>AUX 1 + AUX 2: Total maximum alarm current = 500 mA; (1000 mA is available if you reduce the total available control panel NACs alarm current by the amount of AUX 1 + AUX 2 alarm current over 500 mA)</p> <p>Output: 28.3 to 21.9 VDC, special application</p> <p>Note: For a complete list of devices that can be connected to this circuit, see the <i>FX-64 and FX-1000 Series Compatibility List</i> (P/N 3102355).</p>	

	FX-64 panel	FX-1000 panel
Loop circuit	<p>Maximum loop resistance: 66 Ω Maximum loop capacitance: 0.5 μF Isolation voltage threshold: 3.0 VDC or less Communication line voltage: Maximum 20.6 V peak-to-peak Operating current (fully loaded loop) Stand by: 55 mA/45 mA Alarm: 125 mA/115 mA (this does not include two-wire smoke modules) Circuit current: 0.5 A max. Max. resistance between isolators: Limited only by overall wire run lengths 64 isolators maximum per loop (total both isolator bases and modules)</p>	
Batteries	<p>Type: Sealed lead acid Voltage: 24 VDC Charging current: 2.47 A max. Amp hour capacity: 26 Ah Standby operation: 24 hour or 60 hour Placement: Up to two 10 Ah batteries will fit in the FX-64 control panel cabinet and two 18 Ah batteries will fit in the FX-1000 control panel cabinet. If larger batteries are required, you must use an Edwards battery cabinet.</p>	
SA-DACT dialer	<p>Phone line type: One or two loop-start lines on a public, switched network Phone line connector: RJ-31/38X (C31/38X) Communication formats: Contact ID (SIA DC-05) Operating current Standby/Alarm: 41 mA Max.: 100 mA FCC registration number: GESAL01BSADACT Industry Canada Registration number: 3944A-SADACT Ringer equivalence number: 0.1B</p>	
Ground fault impedance	0 to 5 k Ω	
Alarm contact	Class E, Form C N.O. 24 VDC at 1 A (resistive load)	
Trouble contact	Class E, Form C 24 VDC at 1 A (resistive load)	
Supervisory contact	Class E, Form A N.O. 24 VDC at 1 A (resistive load)	
Environmental	<p>Temperature: 0 to 49°C (32 to 120°F) Relative humidity: 0 to 93% noncondensing</p>	
Terminal rating	All terminals rated for 12 to 18 AWG (0.75 to 2.5 mm ²)	

Appendix B

Worksheets

Summary

This appendix contains all of the worksheets needed to program the panel, calculate NAC requirements and battery requirements.

Content

Battery calculation worksheet	200
Notification appliance circuit calculations worksheet	205
Introduction	205
What you'll need	205
Worksheet method	207
Equation method	208
Notification appliance voltage drop calculation worksheet	211
RZI16-2RS 24V IN riser maximum wire run calculation	213
Device loop maximum wire length worksheet	214
Correlation groups worksheet	218
Device settings worksheet	219
Loop worksheet	222
Panel configuration worksheet	223
Panel operation worksheet	226
Zone settings worksheet	227

Battery calculation worksheet

Use this worksheet to determine the minimum amp hour capacity required for the panel's standby battery. You can obtain operating current requirements for notification appliances from their respective installation sheets.

Battery calculation worksheet

	Standby current (mA)	Alarm (Fire) current (mA)	
Control panel (use Worksheet A and place totals here)	<input style="width: 100%; height: 30px;" type="text"/>	<input style="width: 100%; height: 30px;" type="text"/>	
Auxiliary/smoke power (use Worksheet B and place totals here)	<input style="width: 100%; height: 30px;" type="text"/>	<input style="width: 100%; height: 30px;" type="text"/>	
NAC 1	<input style="width: 100%; height: 30px;" type="text"/>	<input style="width: 100%; height: 30px;" type="text"/>	
NAC 2	<input style="width: 100%; height: 30px;" type="text"/>	<input style="width: 100%; height: 30px;" type="text"/>	
NAC 3	<input style="width: 100%; height: 30px;" type="text"/>	<input style="width: 100%; height: 30px;" type="text"/>	
NAC 4	<input style="width: 100%; height: 30px;" type="text"/>	<input style="width: 100%; height: 30px;" type="text"/>	
Total current	<input style="width: 100%; height: 30px;" type="text"/>	<input style="width: 100%; height: 30px;" type="text"/>	
Operating time required	× <input style="width: 50px;" type="text"/> hr	× <input style="width: 50px;" type="text"/> min	
	<hr style="width: 100%;"/>	<hr style="width: 100%;"/>	
Total CO mAh (from Worksheet C) [2]		÷ 60	
<input style="width: 150px;" type="text"/>	+	<input style="width: 150px;" type="text"/>	+
		<input style="width: 150px;" type="text"/>	=
			<input style="width: 100px;" type="text"/> mAh
			× 1.2
			<hr style="width: 100%;"/>
			<input style="width: 100px;" type="text"/> mAh
			÷ 1,000
			<hr style="width: 100%;"/>
Battery size [1]			<input style="width: 100px;" type="text"/> Ah

[1] Battery size may not exceed 26 Ah for UL/ULC systems. See Appendix A “Panel specifications” on page 195 and “Battery wiring (TB8)” on page 8 for battery details.

[2] Worksheet C for CO device current loads is not required if the system is monitored by a supervising station with emergency response per NFPA 720.

Worksheet A: Control panel current load

Devices	Qty	Standby current (mA)	Alarm current (mA)	Qty x Standby current (mA)	Qty x Alarm current (mA)
Base panel	1	See note [1] below	See note [2] below		
First loop on 1st SLC card (fully loaded loop)		55	80		
Second loop on 1st SLC card (fully loaded loop)		45	70		
First loop on 2nd SLC card (fully loaded loop)		55	80		
Second loop on 2nd SLC card (fully loaded loop)		45	70		
SA-CLA Class A card		3	60		
SA-232 RS-232 card		13	13		
SA-USB USB card		14	20		
SA-FSB card		120	120		
SA-DACT dialer		41	41		
SA-ETH network card		34	34		
LED expander		4	1 expander: 48 2 expanders: 96		
Total (mA)					
			x 1.25 = (panel to battery standby current)		x 1.25 = (panel to battery alarm current)

Totals (mA)
(transfer totals to Battery Calculation Worksheet)

[1] FX-64: 155
FX-1000: 172

[2] FX-64: 204
FX-1000: 267

Worksheet B: Auxiliary/smoke power current load

Devices	Qty	Standby current (mA)	Alarm current (mA)	Qty x Standby current (mA)	Qty x Alarm current (mA)
RPM	<input style="width: 40px; height: 20px;" type="text"/>	28	270	<input style="width: 100%; height: 20px;" type="text"/>	<input style="width: 100%; height: 20px;" type="text"/>
FX-2WIRE [1]	<input style="width: 40px; height: 20px;" type="text"/>	2	17	<input style="width: 100%; height: 20px;" type="text"/>	<input style="width: 100%; height: 20px;" type="text"/>
RLCD(F)	<input style="width: 40px; height: 20px;" type="text"/>	98	113	<input style="width: 100%; height: 20px;" type="text"/>	<input style="width: 100%; height: 20px;" type="text"/>
RLCD-C(F)	<input style="width: 40px; height: 20px;" type="text"/>	99	115	<input style="width: 100%; height: 20px;" type="text"/>	<input style="width: 100%; height: 20px;" type="text"/>
RLED-C(F)	<input style="width: 40px; height: 20px;" type="text"/>	28	62	<input style="width: 100%; height: 20px;" type="text"/>	<input style="width: 100%; height: 20px;" type="text"/>
GCI	<input style="width: 40px; height: 20px;" type="text"/>	36	146	<input style="width: 100%; height: 20px;" type="text"/>	<input style="width: 100%; height: 20px;" type="text"/>
LED24	<input style="width: 40px; height: 20px;" type="text"/>	6	34	<input style="width: 100%; height: 20px;" type="text"/>	<input style="width: 100%; height: 20px;" type="text"/>
RZI16-2 [2]	<input style="width: 40px; height: 20px;" type="text"/>	200	800	<input style="width: 100%; height: 20px;" type="text"/>	<input style="width: 100%; height: 20px;" type="text"/>
Sounder base	<input style="width: 40px; height: 20px;" type="text"/>	[4]	[4]	<input style="width: 100%; height: 20px;" type="text"/>	<input style="width: 100%; height: 20px;" type="text"/>
	<input style="width: 40px; height: 20px;" type="text"/>			<input style="width: 100%; height: 20px;" type="text"/>	<input style="width: 100%; height: 20px;" type="text"/>
	<input style="width: 40px; height: 20px;" type="text"/>		Total Aux Standby current = (cannot exceed 500mA)	<input style="width: 100%; height: 20px;" type="text"/>	[3] <input style="width: 100%; height: 20px;" type="text"/>
	<input style="width: 40px; height: 20px;" type="text"/>		x 1.25 = (AUX to battery standby current)	<input style="width: 100%; height: 20px;" type="text"/>	x 1.25 = (AUX to battery alarm current)
	<input style="width: 40px; height: 20px;" type="text"/>			<input style="width: 100%; height: 20px;" type="text"/>	<input style="width: 100%; height: 20px;" type="text"/>
Totals (mA) (transfer totals to Battery Calculation Worksheet)				<input style="width: 100%; height: 20px;" type="text"/>	<input style="width: 100%; height: 20px;" type="text"/>

[1] Enter 1 regardless of how many are installed. Only the first FX-2WIRE in the alarm state draws current. The other ones do not because the system load sheds additional modules in alarm.

[2] If the panel AUX 1 is used to power an RZI16-2RS, the NAC alarm current must be reduced by the total AUX alarm current amount over 500 mA.

[3] Total AUX alarm current =

1000 mA max for AUX 1*

1000 mA max for (AUX 1 + AUX 2)*

500 mA max for AUX 2

*You must reduce the total NAC alarm current by the total amount of AUX 1 + AUX 2 alarm current over 500 mA.

[4] See the sounder base installation sheet for currents

Worksheet C: CO device current load

For a system using CO devices, determine the total amount of CO signal current in milliamps required by all of the CO devices that derive power from the battery while the panel is in CO alarm mode. Use the alarm currents on the sounder base installation sheet for your calculations. Multiply the total amount of CO signal current by 12 hours to obtain the mAh value used in the Battery Calculation Worksheet.

CO signaling devices	CO signal current (mA)
Sounder base [1]	<input type="text"/>
Other	<input type="text"/>
	<input type="text"/>
	<input type="text"/>
Total (mA)	<input type="text"/>
	X 12 hr
Total (mAh) (transfer total to Battery Calculation Worksheet)	<input type="text"/> mAh

[1] Total CO sounder base alarm current from Worksheet B

Notification appliance circuit calculations worksheet

Introduction

This topic shows you how to determine the maximum cable length of a notification appliance circuit (NAC) for a given number of appliances.

Two methods are presented: worksheet and equation. The worksheet method is simpler, but your installation must meet the criteria listed on the worksheet. If your installation does not meet these criteria, you need to use the equation method.

The methods given here determine cable lengths that work under all operating conditions. The calculations ensure that the required operating voltage and current are supplied to all notification appliances. To do this, we assume these two worst-case conditions:

- The voltage at the NAC terminals is the minimum provided by the power supply
- The notification appliances are clustered at the end of the NAC cable

Other, more detailed methods that distribute the appliance load along the NAC cable may indicate that longer cable runs are possible.

What you'll need

Appliance and cable values

Whether you use the worksheet method or the equation method, you'll need to know:

- The minimum operating voltage required for the appliances
- The maximum operating current drawn by each appliance
- The resistance per unit length of the wire used ($\Omega/\text{ft.}$)

This information can be found on the appliance installation sheets and on the cable specification sheet.

Power supply values

For either method, you'll need some fixed or calculated operating values for your specific power supply. The fixed values are:

- Source voltage = 20.4 V
- Load factor for FX-64 panel = 0.20 V/A
- Load factor for FX-1000 panel = 0.24 V/A
- Power type = FWR

The *source voltage* is the theoretical operating minimum for the power supply, and is calculated as 85% of 24 volts.

The *load factor* is a measure of how the power supply voltage reacts when a load is applied. The load factor measures the voltage drop per ampere of current drawn by the load.

The *power type* reflects the type of power supplied to the NAC terminals at minimum voltage. The current draw of notification appliances can vary substantially with the type of power supplied: full-wave rectified (VFWR) or regulated and filtered DC (R&F). It is important to know the power type at minimum terminal voltage.

You'll need to calculate the following values relating to your power supply and to the NAC circuit current. These are:

- Minimum voltage
- Voltage drop

The *minimum voltage* is the lowest voltage measured at the NAC terminals when the power supply is under the maximum load for that circuit (i.e., for the appliances that constitute the NAC.)

The *voltage drop* is the difference between the minimum voltage and 18.4 V for the RZI16-2 24V IN. This value is for use with this worksheet only.

Worksheet method

Use this worksheet to determine the maximum cable length of a notification appliance circuit for a given number of appliances.

Use this worksheet only if all the appliances are regulated. That is, they must have a minimum operating voltage of 16 V. For other appliances, use the “Equation method.”

NAC cable length

		NAC1	NAC2	NAC3	NAC4	
Total operating current [1]		<input type="text"/>	<input type="text"/>	<input type="text"/>	<input type="text"/>	A
Load factor (FX-64 panel)	×	<input type="text" value="0.20"/>	<input type="text" value="0.20"/>	<input type="text" value="0.20"/>	<input type="text" value="0.20"/>	V/A
Load factor (FX-1000 panel)		<input type="text" value="0.24"/>	<input type="text" value="0.24"/>	<input type="text" value="0.24"/>	<input type="text" value="0.24"/>	
Load voltage drop	=	<input type="text"/>	<input type="text"/>	<input type="text"/>	<input type="text"/>	V
Source voltage		<input type="text" value="20.4"/>	<input type="text" value="20.4"/>	<input type="text" value="20.4"/>	<input type="text" value="20.4"/>	V
Load voltage drop	-	<input type="text"/>	<input type="text"/>	<input type="text"/>	<input type="text"/>	V
Minimum voltage	=	<input type="text"/>	<input type="text"/>	<input type="text"/>	<input type="text"/>	V
Regulated appliance voltage	-	<input type="text" value="16.0"/>	<input type="text" value="16.0"/>	<input type="text" value="16.0"/>	<input type="text" value="16.0"/>	V
Voltage drop [2]	=	<input type="text"/>	<input type="text"/>	<input type="text"/>	<input type="text"/>	V
Total operating current	÷	<input type="text"/>	<input type="text"/>	<input type="text"/>	<input type="text"/>	A
Maximum resistance	=	<input type="text"/>	<input type="text"/>	<input type="text"/>	<input type="text"/>	Ω
Wire resistance (Ω/ft) [3]	÷	<input type="text"/>	<input type="text"/>	<input type="text"/>	<input type="text"/>	
Maximum wire length	=	<input type="text"/>	<input type="text"/>	<input type="text"/>	<input type="text"/>	ft.
	÷	<input type="text" value="2"/>	<input type="text" value="2"/>	<input type="text" value="2"/>	<input type="text" value="2"/>	
Maximum cable length	=	<input type="text"/>	<input type="text"/>	<input type="text"/>	<input type="text"/>	ft.

[1] Total of the maximum operating currents for all appliances as specified for FWR power. See the appliance installation sheets for operating currents.

[2] This voltage drop is valid for regulated notification appliances only. For unregulated appliances, see “Equation method” on page 208.

[3] Use the manufacturer’s published wire resistance expressed in ohms per foot. For typical values, see Table 51 on page 208.

Equation method

Appliance operating voltage and current

Regulated notification appliances have an operating range from 16 V to 33 V. Use 16 V as the minimum appliance voltage when using regulated notification appliances.

When using special application notification appliances, refer to the installation sheets to determine the minimum appliance voltage required.

What if there are different types of appliances in the NAC, and each type has a different minimum operating voltage? In this case, use the *highest* minimum voltage required by any appliance.

The total current requirement for the appliances is the sum of the individual maximum currents drawn by each appliance when using FWR power. Use the maximum current for the appliance over the 16 V to 33 V range.

If all appliances draw the same maximum current, the total current is the maximum current multiplied by the number of appliances. If different appliance types have different maximum currents, the total current is the sum of the maximum current for each appliance type multiplied by the number of appliances of that type.

Wire resistance

Typical wire resistances are shown in the following table.

Table 50: Typical wire resistances

Wire gauge	Resistance 1-strand uncoated copper		Resistance 7-strand uncoated copper	
	Ω per foot	Ω per meter	Ω per foot	Ω per meter
12 AWG	0.00193	0.00633	0.00198	0.00649
14 AWG	0.00307	0.01007	0.00314	0.01030
16 AWG	0.00489	0.01604	0.00499	0.01637
18 AWG	0.00777	0.02549	0.00795	0.02608

When performing these calculations, always refer to the actual cable supplier documentation and use the actual Ω/ft. (or Ω/m) for the cable being used.

Calculating cable length

1. Calculate the total current (I_{tot}) as the sum of the maximum operating currents for all the appliances.

$$I_{tot} = \sum I_a$$

Where:

Σ = sum of all

I_a = appliance maximum current

Refer to the appliance installation sheets for I_a . Remember to use the maximum operating current specified for FWR power.

- Calculate the minimum voltage (V_m).

$$V_m = V_s - (I_{tot} \times K)$$

Where:

V_s = source voltage

I_{tot} = total current (from above)

K = load factor

FX-64 panel: For the power supply, V_s is 20.4 V and K is 0.20 V/A.

FX-1000 panel: For the power supply, V_s is 20.4 V and K is 0.24 V/A

- Calculate the allowable voltage drop (V_d) between the power supply and the appliances.

$$V_d = V_m - V_a$$

Where:

V_m = minimum voltage (from above)

V_a = appliance minimum voltage

For regulated notification appliances, V_a is 16 V. For special application notification appliances, V_a is the lowest operating voltage specified on the appliance installation sheet.

- Calculate the maximum resistance (R_{max}) for the wire.

$$R_{max} = V_d / I_{tot}$$

Where:

V_d = voltage drop

I_{tot} = total current

- Calculate the maximum length of the cable (L_c), based on the maximum resistance allowed, the resistance of the wire, and the number of wires in the cable (two).

$$L_c = (R_{max} / R_w) / 2$$

Where:

R_{max} = maximum resistance

R_w = wire resistance factor

Example: You are using regulated notification appliances. Assume that the maximum operating current for each appliance is 100 mA for FWR power, and that 20 appliances will be

placed on the NAC. The cable is 12 AWG wire, and the manufacturer specifies a wire resistance factor of 0.002 Ω /ft.

$$\begin{aligned} I_{\text{tot}} &= \Sigma I_a \\ &= 20 \times 0.1 \text{ A} \\ &= 2 \text{ A} \end{aligned}$$

$$\begin{aligned} V_m &= V_r - (I_{\text{tot}} \times K) \\ &= 20.4 \text{ V} - (2 \text{ A} \times 0.20 \text{ V/A}) \\ &= 20.4 \text{ V} - 0.40 \text{ V} \\ &= 20.0 \text{ V} \end{aligned}$$

$$\begin{aligned} V_d &= V_m - V_a \\ &= 20.0 \text{ V} - 16.0 \text{ V} \\ &= 4.0 \text{ V} \end{aligned}$$

$$\begin{aligned} R_{\text{max}} &= V_d / I_{\text{tot}} \\ &= 4.0 \text{ V} / 2.0 \text{ A} \\ &= 2.0 \Omega \end{aligned}$$

$$\begin{aligned} L_c &= (R_{\text{max}} / R_w) / 2 \\ &= (2.0 \Omega / 0.002 \Omega/\text{ft.}) / 2 \\ &= (1,000.0 \text{ ft.}) / 2 \\ &= 500.0 \text{ ft.} \end{aligned}$$

So the maximum wire run for this NAC would be 500 ft. (rounding down for safety).

NAC maximum wire run quick reference tables

Table 51: FX-64 panel

Current	12 AWG	14 AWG	16 AWG	18 AWG
0.5 A	2,228 ft.	1,400 ft.	879 ft.	553 ft.
1.0 A	1,088 ft.	684 ft.	429 ft.	270 ft.
1.5 A	708 ft.	445 ft.	279 ft.	175 ft.
2.0 A	518 ft.	326 ft.	204 ft.	128 ft.
2.5 A	404 ft.	254 ft.	160 ft.	100 ft.

Table 52: FX-1000 panel

Current	12 AWG	14 AWG	16 AWG	18 AWG
0.5 A	2217 ft.	1394 ft.	875 ft.	550 ft.
1.0 A	1,077 ft.	677 ft.	425 ft.	267 ft.
1.5 A	697 ft.	438 ft.	275 ft.	173 ft.
2.0 A	507 ft.	319 ft.	200 ft.	126 ft.
2.5 A	393 ft.	247 ft.	155 ft.	97 ft.

Notification appliance voltage drop calculation worksheet

Use the notification appliance voltage drop calculation worksheet to calculate the voltage drop of your NAC circuits over the distance of your wire.

NAC 1 voltage drop calculations						
Circuit length		Total circuit current [2]		Wire resistance per 1000 ft [1]		Voltage drop
feet	x	amps	x	Ω	$\div 1000 =$	

Panel voltage		Voltage drop		End of line voltage [3]
19.8 V	-		=	

Voltage drop		Panel voltage		Voltage drop %
	\div	19.8 V	=	

NAC 2 voltage drop calculations						
Circuit length		Total circuit current [2]		Wire resistance per 1000 ft [1]		Voltage drop
feet	x	amps	x	Ω	$\div 1000 =$	

Panel voltage		Voltage drop		End of line voltage [3]
19.8 V	-		=	

Voltage drop		Panel voltage		Voltage drop %
	\div	19.8 V	=	

NAC 3 voltage drop calculations						
Circuit length		Total circuit current [2]		Wire resistance per 1000 ft [1]		Voltage drop
feet	x	amps	x	Ω	$\div 1000 =$	

Panel voltage		Voltage drop		End of line voltage [3]
19.8 V	-		=	

Voltage drop		Panel voltage		Voltage drop %
	\div	19.8 V	=	

NAC 4 voltage drop calculations						
Circuit length		Total circuit current [2]		Wire resistance per 1000 ft [1]		Voltage drop
feet	x	amps	x	Ω	$\div 1000 =$	

Panel voltage		Voltage drop		End of line voltage [3]
19.8 V	-		=	

Voltage drop		Panel voltage		Voltage drop %
	\div	19.8 V	=	

[1] Use the manufacturer's published wire resistance expressed in ohms per foot. For typical values, see Table 51 on page 208.

[2] Use the Maximum operating current at worst-case VFWR from the installation or catalog sheet of each device.

[3] For UL regulated notification appliances, this voltage must not drop below 16 VFWR. For other devices, get the minimum operating VFWR from the installation or catalog sheet.

RZI16-2RS 24V IN riser maximum wire run calculation

Use the APS/BPS notification appliance circuit calculation in the *Remote Booster Power Supply Manual* (P/N 3100485) to calculate maximum wire run distance for RZI16-2RS NAC circuits.

RZI16-2RS 24V IN cable length

		FX-64 AUX1	FX-1000 AUX1	APS/BPS	
Maximum RZI16-2RS alarm current		0.85	0.85	1	A
Load factor	×	0.20	0.24	0.59	
Alarm current voltage drop	=	0.17	0.20	0.59	V
Source minimum voltage		20.40	20.40	19.10	V
Load voltage drop	-	0.17	0.20	0.59	V
Minimum source output voltage	=	20.23	20.20	18.51	V
RZI16-2 minimum input voltage	-	18.40	18.40	18.40	V
Voltage drop [1]	=	1.83	1.80	0.11	V
Total operating current	÷	0.85	0.85	1	A
Maximum wire resistance	=	2.15	2.21	0.11	Ω
Wire resistance (Ω/ft) [2]	÷	0.00198	0.00198	0.00198	
Maximum single wire length	=	1,087	1,142	55	ft.
	÷	2	2	2	
Maximum 2-wire cable length[3]	=	543	535	27.5	ft.

[1] This voltage drop is valid for regulated notification appliances only.

[2] For example, the value shown is typical resistance for 12 AWG 7-strand wire. Use the manufacturer's published wire resistance expressed in ohms per foot. For other typical values, see Table 51 on page 208.

[3] The value shown is for the FX-1000 panel. Maximum RZI16-2RS 24V IN riser cable distance length shown is based on using 12 AWG, 7-strand conductor cable.

Device loop maximum wire length worksheet

Use the instructions provided below to calculate the maximum wire length for a device loop. The maximum wire length is made up of two components: the total amount of wire and the longest circuit path.

Step 1: Total wire

Use the worksheet below to calculate the total amount of wire that you can use to construct a device loop. The total amount of wire is based on the cable manufacturer's capacitance per foot rating. In no case shall the total amount of wire exceed the values listed in Table 54.

$$\begin{array}{r} \text{Cable capacitance} \\ \div \end{array} \frac{500,000 \text{ pF}}{\boxed{}} \text{ pF/ft.} \\ \hline \text{Total wire} \quad \boxed{} \text{ ft.}$$

Table 53: Maximum wire length for the loop

Wire type	18 AWG or 0.75 mm ²	16 AWG or 1.0 mm ²	14 AWG or 1.5 mm ²
Twisted pair, nonshielded 25, 36, 38 pF	20,000 ft. (6096 m)	13,888 ft. (4233 m)	13,157 ft. (4010 m)
Twisted pair, shielded 58, 82, 84 pF	8,621 ft. (2628 m)	6,098 ft. (1859 m)	5,952 ft. (1814 m)
Untwisted pair, unshielded 20, 20, 20 pF	20,000 ft. (6096 m)	20,000 ft. (6096 m)	20,000 ft. (6096 m)

Step 2: Longest path

Use the tables that follow to determine the device loop's longest circuit path. The longest circuit path is based on wire size and type, and the number of detectors, modules, FX-2WIRES installed on the loop. The distances listed are for devices that are evenly distributed on the loop. Please contact your distributor for loop wire distances for devices on an end-loaded loop.

Note: When using the tables to calculate a wire length for the FX-64 panel, do not exceed a total of 64 device addresses (any combination of detectors and modules).

In the illustration below, the longest circuit path (shown in bold lines) is 1,240 ft. (378 m). The total amount of wire comprising the loop is 1,640 ft. (500 m).

Figure 57: Device circuit path diagram

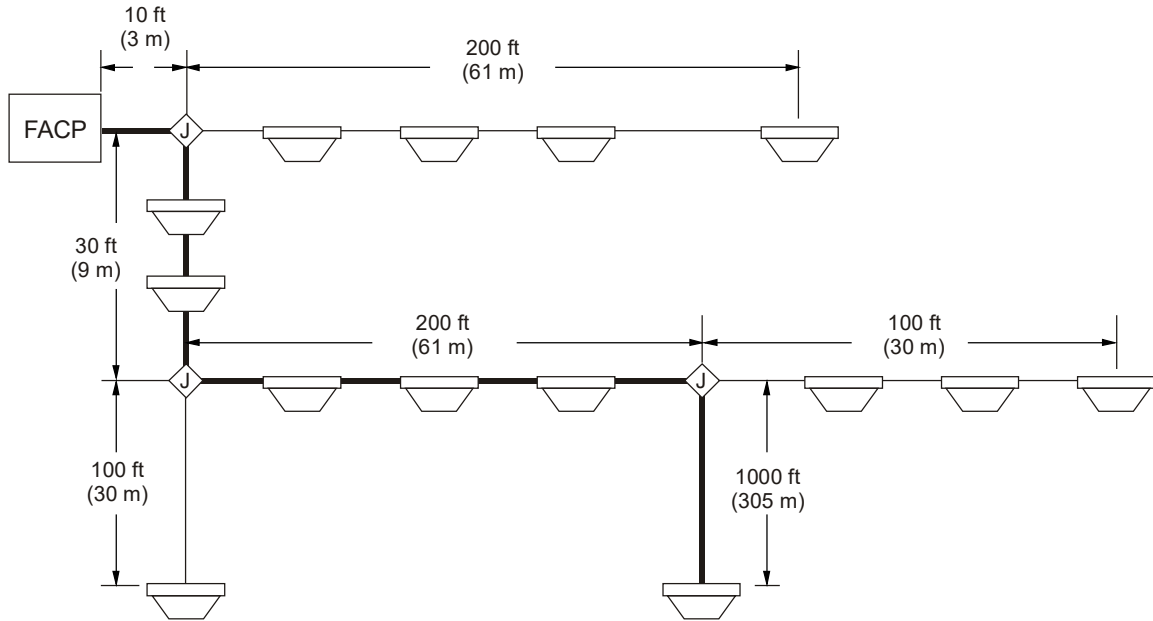

Table 54: Twisted shielded and nontwisted shielded (evenly distributed shielded)

Number of detectors	Number of modules (1 or 2 channel)	Maximum allowable wire distance using Twisted shielded and nontwisted shielded wire pairs (evenly distributed shielded)					
		18 AWG		16 AWG		14 AWG	
		ft.	m	ft.	m	ft.	m
1 to 25	0 to 75	5172	1577	6098	1859	5952	1815
26 to 50	0 to 75	5172	1577	6098	1859	5952	1815
51 to 75	0 to 75	5172	1577	6098	1859	5952	1815
76 to 100	0 to 75	5172	1577	6098	1859	5952	1815
101 to 125	0 to 75	5172	1577	6098	1859	5952	1815
0	76 to 100	5172	1577	6098	1859	5952	1815
1 to 25	76 to 100	5172	1577	6098	1859	5952	1815
26 to 50	76 to 100	5172	1577	6098	1859	5952	1815
51 to 75	76 to 100	5172	1577	6098	1859	5952	1815
76 to 100	76 to 100	5172	1577	6098	1859	5952	1815
101 to 125	76 to 100	5172	1577	6098	1859	5952	1815
0	101 to 125	5172	1577	6098	1859	5952	1815
1 to 25	101 to 125	5172	1577	6098	1859	5952	1815
26 to 50	101 to 125	5172	1577	6098	1859	5952	1815
51 to 75	101 to 125	5172	1577	6098	1859	5952	1815
76 to 100	101 to 125	5172	1577	6098	1859	5952	1815
101 to 125	101 to 125	5172	1577	6098	1859	5952	1815

Table 55: Twisted shielded and nontwisted shielded (end loaded shielded)

Number of detectors	Number of modules (1 or 2 channel)	Maximum allowable wire distance using Twisted shielded and nontwisted shielded wire pairs (end loaded shielded)					
		18 AWG		16 AWG		14 AWG	
		ft.	m	ft.	m	ft.	m
1 to 25	0 to 75	5172	1577	6098	1859	5952	1815
26 to 50	0 to 75	5172	1577	6098	1859	5952	1815
51 to 75	0 to 75	5171	1577	6098	1859	5952	1815
76 to 100	0 to 75	4966	1514	6098	1859	5952	1815
101 to 125	0 to 75	4777	1456	6098	1859	5952	1815
0	76 to 100	4426	1349	6098	1859	5952	1815
1 to 25	76 to 100	4275	1303	6098	1859	5952	1815
26 to 50	76 to 100	4134	1260	6098	1859	5952	1815
51 to 75	76 to 100	4002	1220	6098	1859	5952	1815
76 to 100	76 to 100	3878	1182	6098	1859	5952	1815
101 to 125	76 to 100	3762	1147	5976	1822	5952	1815
0	101 to 125	3540	1079	5625	1715	5952	1815
1 to 25	101 to 125	3443	1050	5470	1668	5952	1815
26 to 50	101 to 125	3351	1022	5324	1623	5952	1815
51 to 75	101 to 125	3264	995	5185	1581	5952	1815
76 to 100	101 to 125	3181	970	5054	1541	5952	1815
101 to 125	101 to 125	3102	946	4929	1503	5952	1815

Table 56: Twisted non-shielded and nontwisted non-shielded (evenly distributed non-shielded)

Number of detectors	Number of modules (1 or 2 channel)	Maximum allowable wire distance using Twisted shielded and nontwisted shielded wire pairs (evenly distributed non-shielded)					
		18 AWG		16 AWG		14 AWG	
		ft.	m	ft.	m	ft.	m
1 to 25	0 to 75	5172	1577	8217	2505	13069	3984
26 to 50	0 to 75	5172	1577	8217	2505	13069	3984
51 to 75	0 to 75	5172	1577	8217	2505	13069	3984
76 to 100	0 to 75	5172	1577	8217	2505	13069	3984
101 to 125	0 to 75	5172	1577	8217	2505	13069	3984
0	76 to 100	5172	1577	8217	2505	13069	3984
1 to 25	76 to 100	5172	1577	8217	2505	13069	3984
26 to 50	76 to 100	5172	1577	8217	2505	13069	3984
51 to 75	76 to 100	5172	1577	8217	2505	13069	3984
76 to 100	76 to 100	5172	1577	8217	2505	13069	3984
101 to 125	76 to 100	5172	1577	8217	2505	13069	3984
0	101 to 125	5172	1577	8217	2505	13069	3984
1 to 25	101 to 125	5172	1577	8217	2505	13069	3984
26 to 50	101 to 125	5172	1577	8217	2505	13069	3984
51 to 75	101 to 125	5172	1577	8217	2505	13069	3984
76 to 100	101 to 125	5172	1577	8217	2505	13069	3984
101 to 125	101 to 125	5172	1577	8217	2505	13069	3984

Table 57: Twisted non-shielded and nontwisted non-shielded (end loaded non-shielded)

Number of detectors	Number of modules (1 or 2 channel)	Maximum allowable wire distance using Twisted non-shielded and nontwisted non-shielded wire pairs (end loaded non-shielded)					
		18 AWG		16 AWG		14 AWG	
		ft.	m	ft.	m	ft.	m
1 to 25	0 to 75	5172	1577	8217	2505	13069	3984
26 to 50	0 to 75	5172	1577	8217	2505	13069	3984
51 to 75	0 to 75	5171	1577	8215	2505	13065	3983
76 to 100	0 to 75	4966	1514	7889	2405	12548	3826
101 to 125	0 to 75	4777	1456	7589	2314	12070	3680
0	76 to 100	4426	1349	7031	2144	11182	3409
1 to 25	76 to 100	4275	1303	6791	2070	10801	3293
26 to 50	76 to 100	4134	1260	6567	2002	10445	3184
51 to 75	76 to 100	4002	1220	6358	1938	10112	3083
76 to 100	76 to 100	3878	1182	6161	1878	9799	2988
101 to 125	76 to 100	3762	1147	5976	1822	9505	2898
0	101 to 125	3540	1079	5625	1715	8946	2727
1 to 25	101 to 125	3443	1050	5470	1668	8700	2652
26 to 50	101 to 125	3351	1022	5324	1623	8468	2582
51 to 75	101 to 125	3264	995	5185	1581	8247	2514
76 to 100	101 to 125	3181	970	5054	1541	8038	2451
101 to 125	101 to 125	3102	946	4929	1503	7839	2390

- | | | |
|--|---|--|
| <input type="checkbox"/> Auto sync output Silenceable | <input type="checkbox"/> Heat + CO alarm | <input type="checkbox"/> Genesis-audible silence |
| <input type="checkbox"/> Auto sync output nonsilenceable | <input type="checkbox"/> Heat + CO monitor latching | <input type="checkbox"/> Supervised |
| <input type="checkbox"/> Unlatch outputs | <input type="checkbox"/> Heat + CO monitor nonlatching | <input type="checkbox"/> City tie |
| <input type="checkbox"/> Continuous nonsilenceable (latched) | <input type="checkbox"/> Heat + CO supervisory latching | <input type="checkbox"/> Relay nonsilence NC |
| <input type="checkbox"/> Heat | <input type="checkbox"/> Heat + CO supervisory nonlatching | <input type="checkbox"/> Relay nonsilence NC (latched) |
| <input type="checkbox"/> Alarm | <input type="checkbox"/> Heat ROR + CO alarm | <input type="checkbox"/> Relay nonsilence NO |
| <input type="checkbox"/> Smoke alarm + CO alarm | <input type="checkbox"/> Heat ROR + CO monitor latching | <input type="checkbox"/> Relay nonsilence NO (latched) |
| <input type="checkbox"/> Smoke alarm + CO monitor latching | <input type="checkbox"/> Heat ROR + CO monitor nonlatching | <input type="checkbox"/> Relay nonsilenceable (latched) |
| <input type="checkbox"/> Smoke alarm + CO monitor nonlatching | <input type="checkbox"/> Heat ROR + CO supervisory latching | <input type="checkbox"/> Relay silence |
| <input type="checkbox"/> 2Wire Class A | <input type="checkbox"/> Heat ROR + CO supervisory nonlatching | <input type="checkbox"/> Relay silence NC |
| <input type="checkbox"/> 2Wire Class B | <input type="checkbox"/> Heat + smoke alarm | <input type="checkbox"/> Relay silence NO |
| <input type="checkbox"/> 2Wire verify Class A | <input type="checkbox"/> Heat + supervisory smoke latching | <input type="checkbox"/> Supervised output |
| <input type="checkbox"/> 2Wire verify Class B | <input type="checkbox"/> Heat + supervisory smoke nonlatching | <input type="checkbox"/> Supervised output (latched) |
| <input type="checkbox"/> Smoke alarm + CO supervisory latching | <input type="checkbox"/> Smoke alarm + CO supervisory nonlatching | <input type="checkbox"/> Unlatch outputs |
| <input type="checkbox"/> Smoke supervisory latching + CO alarm | <input type="checkbox"/> Smoke supervisory latching + CO supervisory latching | <input type="checkbox"/> Continuous nonsilenceable (latched) |
| <input type="checkbox"/> Smoke supervisory latching + CO supervisory nonlatching | <input type="checkbox"/> Smoke supervisory latching + CO monitor latching | <input type="checkbox"/> Continuous nonsilenceable Class A (latched) |
| <input type="checkbox"/> Smoke supervisory latching + CO monitor nonlatching | <input type="checkbox"/> Smoke supervisory nonlatching + CO alarm | <input type="checkbox"/> Relay nonsilence NC (latched) |
| <input type="checkbox"/> Smoke supervisory nonlatching + CO supervisory latching | <input type="checkbox"/> Smoke supervisory nonlatching + CO supervisory nonlatching | <input type="checkbox"/> Relay nonsilence NO (latched) latch |
| <input type="checkbox"/> Smoke supervisory nonlatching + CO monitor latching | <input type="checkbox"/> Smoke supervisory nonlatching + CO monitor nonlatching | <input type="checkbox"/> Relay nonsilenceable (latched) |
| <input type="checkbox"/> Smoke verified + CO supervisory latching | <input type="checkbox"/> Smoke verified + CO alarm | <input type="checkbox"/> Supervised output (latched) |
| <input type="checkbox"/> Smoke verified + CO supervisory nonlatching | <input type="checkbox"/> Smoke verified + CO monitor latching | <input type="checkbox"/> Supervised outputs Class A (latched) |
| <input type="checkbox"/> Smoke verified + CO monitor nonlatching | <input type="checkbox"/> Waterflow No Delay | <input type="checkbox"/> Waterflow No Delay Class A |

Event notification

Active

Print Yes No

NET Yes No

Dialer Acct 1 Acct 1 & 2 Acct 2 None

Code

--	--	--	--

 (four-digit coded output)

CID

--	--	--

Trouble

Print Yes No

NET Yes No

Dialer Acct 1 Acct 1 & 2 Acct 2 None

Code

--	--	--	--

 (four-digit coded output)

CID

--	--	--

Disable

Print Yes No

NET Yes No

Dialer Acct 1 Acct 1 & 2 Acct 2 None

Code

--	--	--	--

 (four-digit coded output)

CID

--	--	--

Prealarm

Print Yes No

NET Yes No

Dialer Acct 1 Acct 1 & 2 Acct 2 None

Code

--	--	--	--

 (four-digit coded output)

CID

--	--	--

Alarm verify

Print Yes No

NET Yes No

Dialer Acct 1 Acct 1 & 2 Acct 2 None

Code

--	--	--	--

 (four-digit coded output)

CID

--	--	--

Maintenance alert

Print Yes No

NET Yes No

Dialer Acct 1 Acct 1 & 2 Acct 2 None

Code

--	--	--	--

 (four-digit coded output)

CID

--	--	--

Test

Print Yes No

NET Yes No

Dialer Acct 1 Acct 1 & 2 Acct 2 None

Code

--	--	--	--

 (four-digit coded output)

CID

--	--	--

Loop worksheet

The loop worksheet is used to document your loop settings.

Note: For default settings, see “Factory default settings” on page 43.

Loop class

Loop 1 class Class B Class A

Loop 2 class Class B Class A

Loop 3 class Class B Class A

Loop 4 class Class B Class A

Loop 2 enable Yes No

Loop 3 enable Yes No

Loop 4 enable Yes No

Annunciator

Class Class B Class A
 Type Off LCD-C LCD LED Graphic
 Expanders None 1 or 2

Label Line 1

--	--	--	--	--	--	--	--	--	--	--	--	--	--	--	--	--	--	--	--

 Label Line 2

--	--	--	--	--	--	--	--	--	--	--	--	--	--	--	--	--	--	--	--

Event notification

Trouble

Print Yes No
 NET (1-8) Yes No
 Dialer Acct 1 Acct 1 & 2 Acct 2 None
 Code

--	--	--	--

 (four-digit coded output)
 CID

--	--	--

Remote devices

Dialer

Type Dual line Single line Modem only None

Account 1

ID

--	--	--	--

 (four-digit account ID code)
 Primary receiver

--	--	--	--	--	--	--	--	--	--	--	--	--	--	--	--	--	--	--	--

 Secondary receiver

--	--	--	--	--	--	--	--	--	--	--	--	--	--	--	--	--	--	--	--

 Format CID
 Send restorals Yes No
 Retry time

--	--

 (01 – 45 seconds)
 Retry count

--	--

 (01 – 10 attempts)
 Event notification Device reporting Zone reporting Event reporting

Account 2

ID

--	--	--	--

 (four-digit account ID code)
 Primary receiver

--	--	--	--	--	--	--	--	--	--	--	--	--	--	--	--	--	--	--	--

 Secondary receiver

--	--	--	--	--	--	--	--	--	--	--	--	--	--	--	--	--	--	--	--

 Format CID
 Send restorals Yes No
 Retry time

--	--

 (01 – 45 seconds)
 Retry count

--	--

 (01 – 10 attempts)
 Event notification Device reporting Zone reporting Event reporting

Panel operation worksheet

The panel operation worksheet is used to document the configuration and settings of your control panel programming options.

Note: For default settings, see “Factory default settings” on page 43.

Language English French Portuguese Spanish

Marketplace U.S. Canada Intl. (International)

AC fail delay Off

--	--

 (01 – 15 hours)

Zone resound Off On

Reset inhibit Off 1 minute

Auto signal silence Off

--	--

 (05 – 30 minutes)

In suite signal sil.

--	--

 (01 – 10 minutes)

Day start Start time

--	--	--	--

 End time

--	--	--	--

Night start Start time

--	--	--	--

 End time

--	--	--	--

Date format U.S. (MM/DD/YYYY) Canada (DD/MM/YYYY)

Event notification Zone/device reporting Zone only reporting Device only reporting

Standalone Op No Yes

LCD banner

Line 1

--	--	--	--	--	--	--	--	--	--	--	--	--	--	--	--	--	--	--	--

Line 2

--	--	--	--	--	--	--	--	--	--	--	--	--	--	--	--	--	--	--	--

Aux power reset On Off

User key #1 Enabled Disabled

User key #2 Enabled Disabled

Zone settings worksheet

The zone settings worksheet is used to document the configuration and settings for each of the zones on the system.

Note: Print a copy of this worksheet for each zone in the system.

Note: For default settings, see “Factory default settings” on page 43.

Type Alarm Waterflow Monitor
 Supervisory (latching) Supervisory (nonlatching)

Label Line 1

--	--	--	--	--	--	--	--	--	--	--	--	--	--	--	--	--	--	--	--	--

Label Line 12

--	--	--	--	--	--	--	--	--	--	--	--	--	--	--	--	--	--	--	--	--

Correlation groups

Device allocation

First address

--	--	--	--

(no less than the last address of the previous zone + 1)

Last address

--	--	--	--

(first address + the number of devices – 1)

Event notification

Active

Print Yes No

NET (1-8) Yes No

Dialer Acct 1 Acct 1 & 2 Acct 2 None

Code

--	--	--	--

 (four-digit coded output)

CID

--	--	--

Trouble

Print Yes No

NET (1-8) Yes No

Dialer Acct 1 Acct 1 & 2 Acct 2 None

Code

--	--	--	--

 (four-digit coded output)

CID

--	--	--

Disable

Print Yes No

NET (1-8) Yes No

Dialer Acct 1 Acct 1 & 2 Acct 2 None

Code

--	--	--	--

 (four-digit coded output)

CID

--	--	--

Prealarm

Print Yes No

NET (1-8) Yes No

Dialer Acct 1 Acct 1 & 2 Acct 2 None

Code

--	--	--	--

 (four-digit coded output)

CID

--	--	--

Alarm verify

Print Yes No

NET (1-8) Yes No

Dialer Acct 1 Acct 1 & 2 Acct 2 None

Code

--	--	--	--

 (four-digit coded output)

CID

--	--	--

Maintenance alert

Print Yes No

NET (1-8) Yes No

Dialer Acct 1 Acct 1 & 2 Acct 2 None

Code

--	--	--	--

 (four-digit coded output)

CID

--	--	--

Test

Print Yes No

NET (1-8) Yes No

Dialer Acct 1 Acct 1 & 2 Acct 2 None

Code

--	--	--	--

 (four-digit coded output)

CID

--	--	--

Appendix C

Applications

Summary

This appendix has sounder base applications that can be used with compatible sounder bases.

Content

CAN/ULC-S559 applications 230

- Introduction 230

- Application summary 230

- Fire alarm control unit to signal receiving center 231

- Fire alarm control unit to proprietary signal receiving center 232

Local alarm signaling applications 233

- What is local alarm signaling? 233

- Programming sounder bases for a local alarm signaling application 234

- Programming sounder bases for a T3T4 Fire Alarm/CO emergency signaling application per NFPA 720, UL 2017 235

Correlated zone and system alarm signaling applications 237

- Zone alarm signaling applications 237

- System alarm signaling applications 239

- Programming sounder bases for a local alarm signaling application 241

SA-FSB Building Management System Communication 242

KESMobile and Web Portal System 242

In-suite signal silence applications 243

CAN/ULC-S559 applications

Introduction

This topic defines CAN/ULC-S559 compliant configurations for a fire signal receiving center application and a proprietary fire signal receiving center application.

Compliant systems must be installed in accordance with all of the following:

- The installation instructions given in this manual
- The applicable edition of CAN/ULC-S524 and CAN/ULC-S527
- The applicable edition of CAN/ULC-S561
- The Canadian Electrical Code, Part 1
- Any applicable local codes and regulations

The configurations shown here illustrate the specific applications that are included in the CAN/ULC-S559 listing of this equipment.

We recommend that you research and verify all applicable regulatory requirements, including consulting with local authorities, as there may be additional requirements, depending on your application.

Application summary

The following table summarizes the CAN/ULC-S559 applications covered in this topic, and describes the communication link used.

Table 58: CAN/ULC-S559 applications

Application	Communication link	Page
Signal Receiving Center From a listed fire alarm system control unit	Internet (IP) connection Using a compatible dialer capture Ethernet module to a central monitoring station	231
Proprietary Signal Receiving Center From a listed fire alarm system control unit	Internet (IP) connection Using a compatible dialer capture Ethernet module to a FireWorks system control workstation	232

Fire alarm control unit to signal receiving center

Note: Connecting to a central monitoring station (CMS) using a TCP/IP Ethernet network does not comply with CAN/ULC S559 3rd edition requirements.

Configuration: FACP connection to signal receiving center.

Interconnections: Internet communication link (direct or via LAN) or POTS.

Figure 58: Fire alarm control unit to signal receiving center

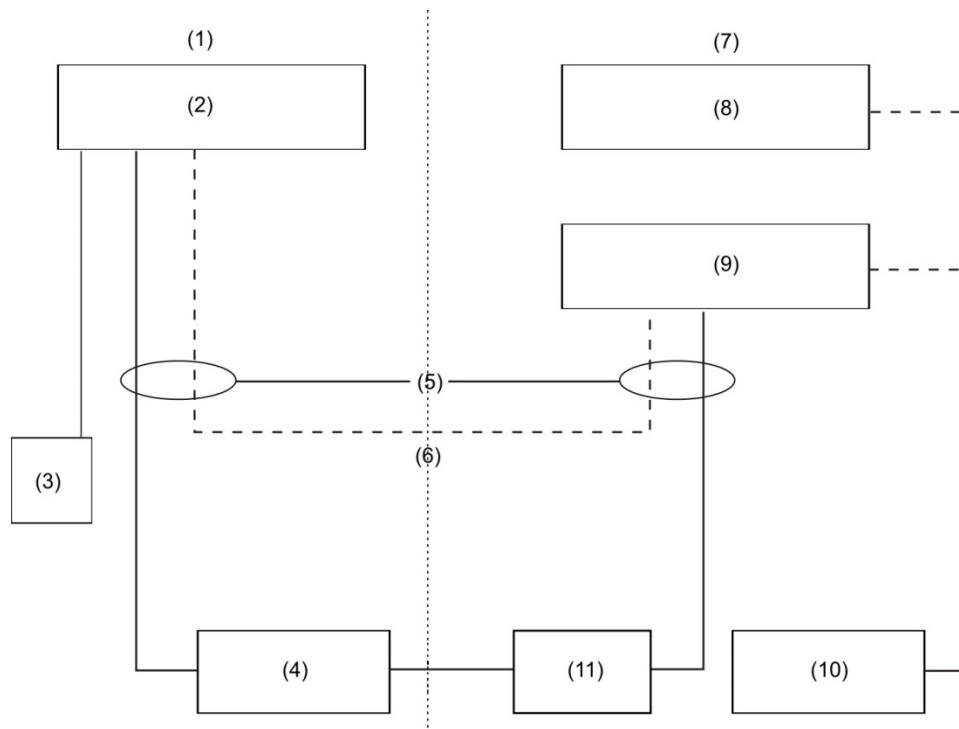

- | | |
|---|--|
| (1) Protected premises | (7) Signal receiving center |
| (2) FACP Fire alarm system control unit
ULC-S559 listed. See "SA-DACT wiring" on page
21 for module wiring details. | (8) CMS Central monitoring system |
| (3) Optional listed local printer | (9) Signal receiving equipment ULC-S559 Listed |
| (4) Compatible dialer capture Ethernet module | (10) Listed local printer |
| (5) Phone lines | (11) Internet |
| (6) Optional: In this configuration, the central station
link is continuously supervised, so the secondary
POTS (plain old telephone system) connection is
not required for a listed communication link. | |

Fire alarm control unit to proprietary signal receiving center

Note: Connecting to a central monitoring station (CMS) using a TCP/IP Ethernet network does not comply with CAN/ULC S559 3rd edition requirements.

Configuration: FACP connection to proprietary signal receiving center.

Interconnections: Internet communication link (direct or via LAN) or POTS.

Figure 59: Fire alarm control unit to proprietary signal receiving center

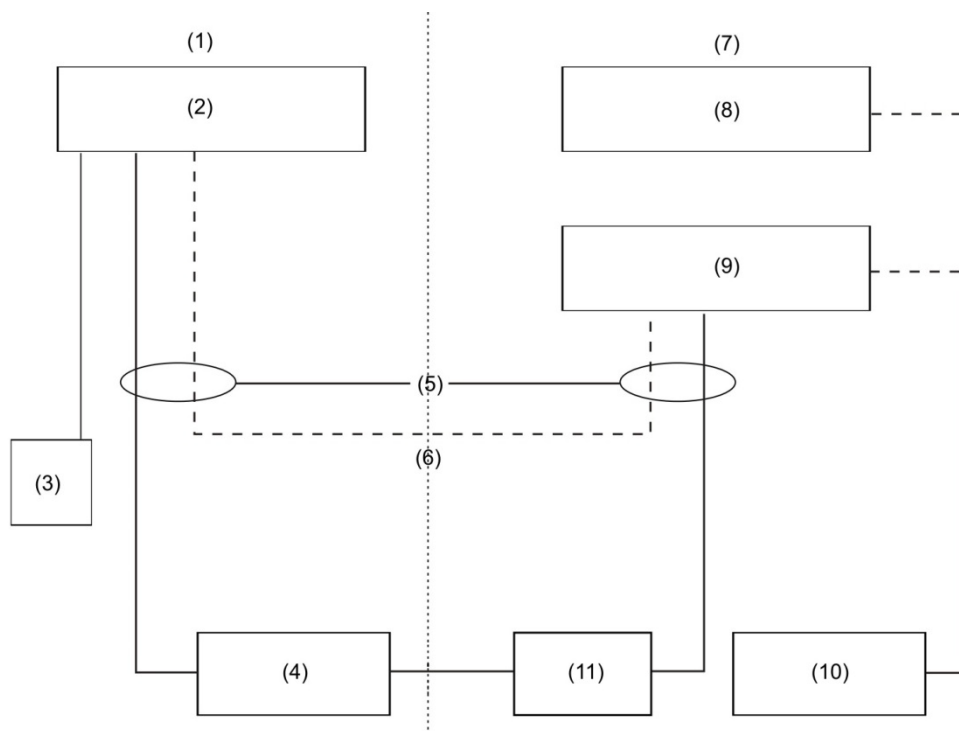

- | | |
|---|--|
| (1) Protected premises | (7) Signal receiving center |
| (2) FACP Fire alarm system control unit
ULC-S559 listed. See “SA-DACT wiring” on page
21 for module wiring details. | (8) FireWorks System Control workstation |
| (3) Optional listed local printer | (9) Signal receiving equipment ULC-S559 Listed |
| (4) Compatible dialer capture ethernet module | (10) Listed local printer |
| (5) Phone lines | (11) Internet |
| (6) Optional: In this configuration, the central station
link is continuously supervised, so the secondary
POTS (plain old telephone system) connection is
not required for a listed communication link. | |

Local alarm signaling applications

What is local alarm signaling?

In local alarm signaling applications, an audible detector base (sounder base) automatically sounds an alarm signal when its detector is activated. All other sounder bases on the same riser remain silent until their detectors are activated.

The sounder base continues to sound an alarm signal until smoke is cleared from its detector and the control panel is reset.

Typical wiring for a local alarm signaling application

The 24 VDC riser that supplies power to the sounder bases is supervised using a FX-NAC Analog NAC Module.

Figure 60: Typical wiring for a local alarm signaling application

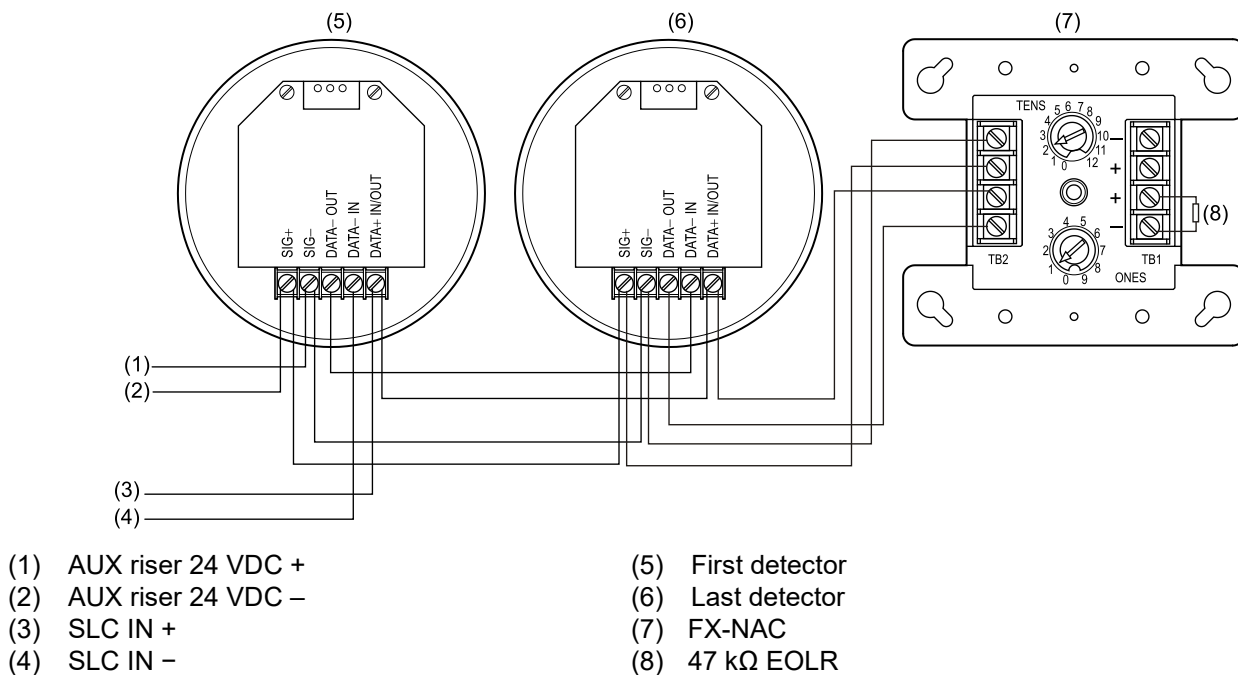

Programming sounder bases for a local alarm signaling application

Note: For PD, PHD, and PDD detectors configured as “Supervisory Non-latching” device type or for PCD detectors (smoke element) configured as “Smoke Supervisory Non-latching” device type, if the base is Relay/Sounder, then the follow type option cannot be configured as “Head.” The follow type in this case should be set to “Alarm.”

1. Set the panel’s Event Notification option to Device.
2. Configure the smoke detectors as follows.

Device Type: Smoke or Smoke Heat depending on the detector model

Message Line 1: Description of the installed detector location

Base Type: Sounder

Follow: Head

3. Configure the FX-NAC module as follows:

Device type: Supervised Output

Message Line 1: 24VDC_RISER

Message Line 2: SOUNDER_CKT_1

Programming sounder bases for a T3T4 Fire Alarm/CO emergency signaling application per NFPA 720, UL 2017

Typical wiring for a T3T4 Fire/CO alarm application

The 24 VDC riser that supplies power to the sounder bases is supervised using a FX-NAC Analog NAC Module.

Figure 61: Wiring the sounder base for a T3T4 Fire/CO alarm

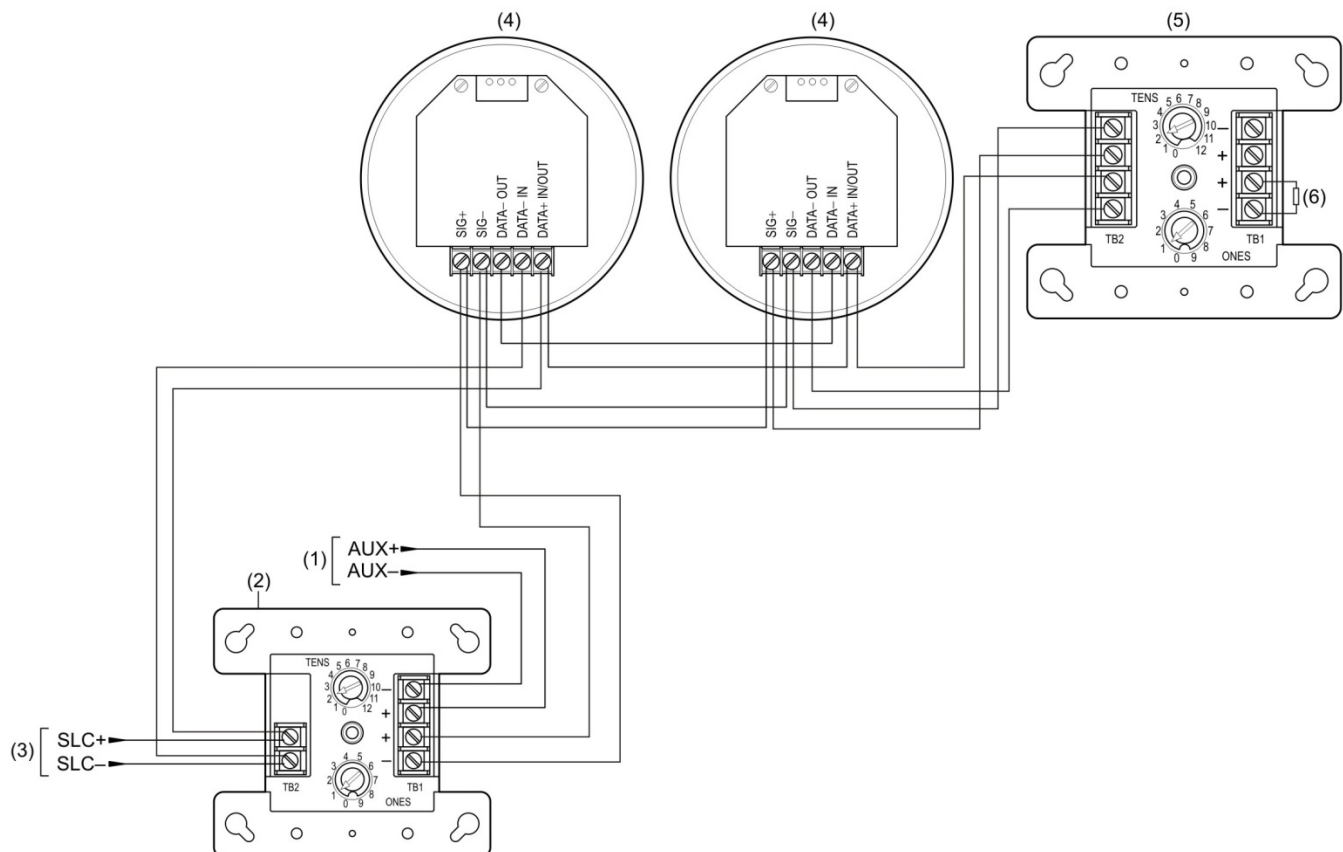

- (1) AUX riser from previous device. Use a power-limited and regulated 24 VDC primary or auxiliary power supply that is UL/ULC Listed for fire protective signaling systems.
- (2) T3T4 module
Note: T3T4+ connects to the SIG- terminal on the sounder base and T3T4- connects to the SIG+ terminal
- (3) Signaling line circuit IN
- (4) Compatible sounder base
- (5) FX-NAC
- (6) 47 kΩ EOLR

Notes

- For PD, PHD, and PDD detectors configured as “Supervisory Non-latching” device type or for PCD detectors (smoke element) configured as “Smoke Supervisory Non-latching” device type, if the base is Relay/Sounder, then the follow type option cannot be configured as “Head.” The follow type in this case should be set to “Alarm.”

- The FX-NAC is used to supervise the 24 VDC riser only. When using the FX-NAC as a riser supervision module, it cannot be used for notification appliances or included in a correlation group.
- The following procedure must be done using the Configuration Utility (CU).

To program the sounder base for T3T4 Fire/CO:

1. Configure the detectors as follows:

Message Line 1: Description of the installed detector location

Device Type: Primary sensor type + CO alarm

Base Type: Sounder

Follow: None, Head, Alarm, Alm + Vrfy, or Alm + PreAlm

Follow CO: No or Yes (only displays if Follow is set to Alarm, Alm + Vrfy, or Alm + PreAlm)

2. Configure the FX-NAC module as follows:

Device type: Supervised Output

Message Line 1: 24VDC_RISER

Message Line 2: SOUNDER_CKT_1

3. Configure Correlation Group 001 as follows:

Add/Remove Zone: As required

Add/Remove NAC: As required

Add/Remove Device: Add all alarm signal initiating devices corresponding T3T4 device Channels as described below

To create correlations for T3T4:

1. Channel 1 must be correlated with proper sounder base as output to any primary alarming type inputs.
2. Channel 2 can be correlated with proper sounder base as output to secondary element (CO) of detectors.
3. If both Channel 1 and Channel 2 are correlated as outputs to a sounder base, then Channel 1 pattern overwrites the Channel 2 pattern.

Notes

- Channel 1: T3T4-TC3 (fire): The device at address visible on T3T4 device.
- Channel 2: T3T4-TC4 (CO): The device at address above plus one.
- CO alarm signals are required to activate TC4 CO evacuation signals. CO supervisory or CO monitor signals are not allowed to activate CO evacuation signals.

- CO alarm, CO supervisory, and CO monitor signals do not activate TC3 fire evacuation signals.

Correlated zone and system alarm signaling applications

Correlated signaling applications are those in which sounder bases are triggered by associated correlation groups. This includes zone alarm and system alarm signaling applications. Detectors are added to the input side, and polarity reversal modules are added to the output side of one or more correlation groups.

Zone alarm signaling applications

What is zone alarm signaling?

In zone alarm signaling applications, detectors and sounder bases are grouped by zone. All sounder bases within a zone automatically sound alarm signals when any detector in the zone initiates an alarm event.

The sounder bases, once activated, continue to sound an alarm signal until:

- Smoke is cleared from the active detectors and the control panel is reset.
- Signal Silence is pressed.
- The control panel's Auto Signal Silence timer expires, if programmed. This can be from 5 to 30 minutes.
- The in-suite signal silence timer expires, if programmed. See "What is in-suite signal silence?" on page 41 and on page 90.

Typical wiring for zone alarm signaling

The 24 VDC riser that supplies power to the sounder bases is supervised using a FX-NAC Analog NAC Module.

Figure 62: Typical wiring for a zone alarm signaling application

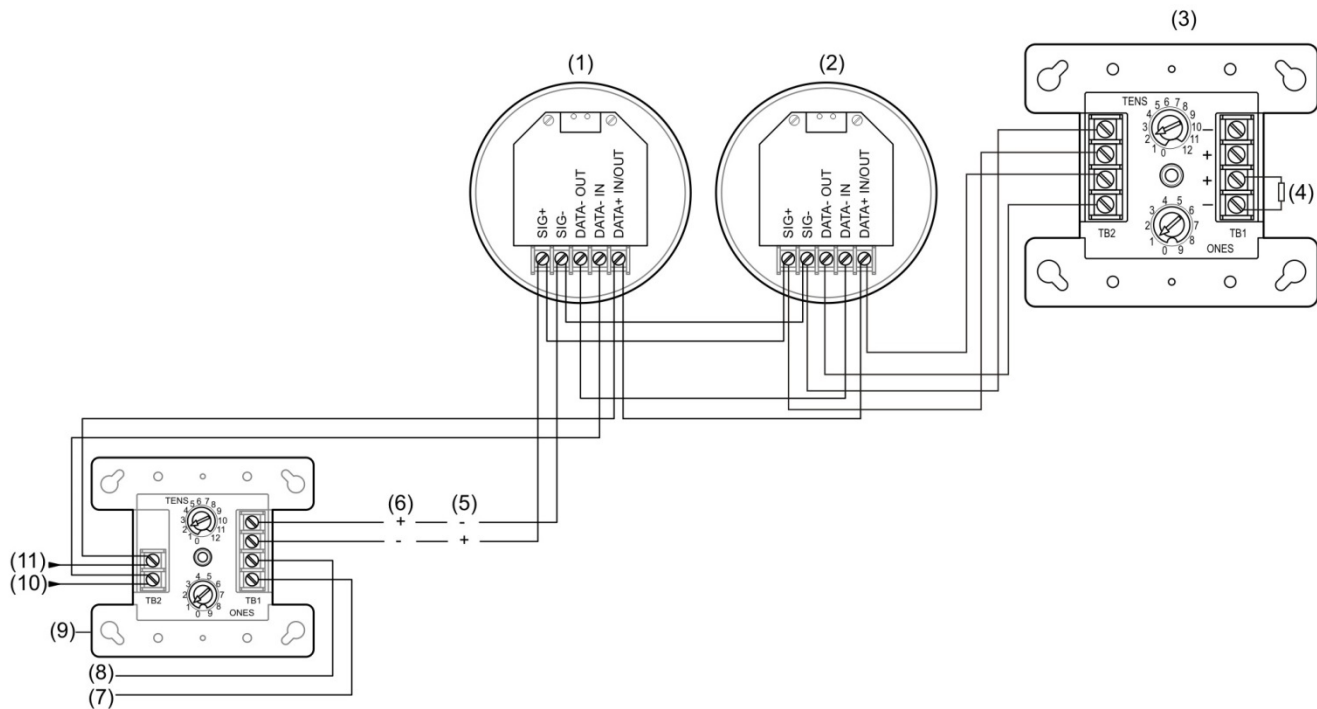

- | | |
|-----------------------------------|------------------------|
| (1) First detector (sounder base) | (7) AUX riser 24 VDC - |
| (2) Last detector (sounder base) | (8) AUX riser 24 VDC + |
| (3) FX-NAC | (9) FX-RLY |
| (4) 47 kΩ EOLR | (10) SLC IN - |
| (5) Active | (11) SLC IN + |
| (6) Normal | |

Programming for zone alarm signaling

This application requires that you group your detectors into zones and correlate outputs for each zone. The following instructions are for Zone 1 but apply for all zones as well.

Note: For PD, PHD, and PDD detectors configured as “Supervisory Non-latching” device type or for PCD detectors (smoke element) configured as “Smoke Supervisory Non-latching” device type, if the base is Relay/Sounder, then the follow type option cannot be configured as “Head.” The follow type in this case should be set to “Alarm.”

To program a zone alarm signaling application:

1. Set the panel’s Event Notification option to Zone.
2. Configure the smoke detectors in Zone 1 as follows:

Device Type: Smoke or Smoke Heat depending on the detector model

Message Line 1: Description of the installed detector location

Message Line 2: ZONE_01

Base Type: Sounder

Follow: None, Alarm, Alm + Vrfy, or Alm + PreAlm

3. Configure the RLY module as follows:

Device Type: Relay Silence

Message Line 1: ZONE_1

Message Line 2: SOUNDERS

Note: The RLY module can be omitted if correlation groups are used to activate the sounder bases.

4. Configure the FX-NAC module as follows:

Device type: Supervised Output

Message Line 1: ZONE_1

Message Line 2: 24VDC_RISER

5. Configure Zone 01 as follows:

Inputs: All detectors in Zone 1

Message Line 1: Zone 1

Type: Alarm

Outputs: The polarity reversal or FX-NAC module labeled ZONE_1_SOUNDERS

Correlation Groups: 001

Status: Included

Note: For best performance, use the fast correlation groups for bulk activations, such as entire floors and save the slower correlation groups for small sets of activations like a suite or hotel room. See “Programming fast groups for sounder bases” on page 90.

6. Configure Correlation 01 as follows:

Inputs: Zone 1

Outputs: The RLY module labeled ZONE_1 SOUNDERS

System alarm signaling applications

What is system alarm signaling?

In system alarm signaling applications, all sounder bases sound when any alarm signal-initiating device is activated. In the following example, all sounder bases on the riser will be synchronized. The 24 VDC riser that supplies power to the sounder bases is supervised using

a FX-NAC Analog NAC Module.

The sounder bases, once activated, continue to sound an alarm signal until:

- Smoke is cleared from the active detectors and the control panel is reset.
- Signal Silence is pressed.
- The control panel’s Auto Signal Silence timer expires, if programmed. This can be from 5 to 30 minutes.
- The in-suite signal silence timer expires, if programmed. See “What is in-suite signal silence?” on page 41 and “Programming in-suite signal silence” on page 90.

Typical wiring for system alarm signaling applications

The figure below shows the typical wiring for synchronized system alarm signaling. The 24 VDC riser that supplies power to the sounder bases is supervised using a FX-NAC Analog NAC Module.

Figure 63: Typical wiring for a system alarm signaling application

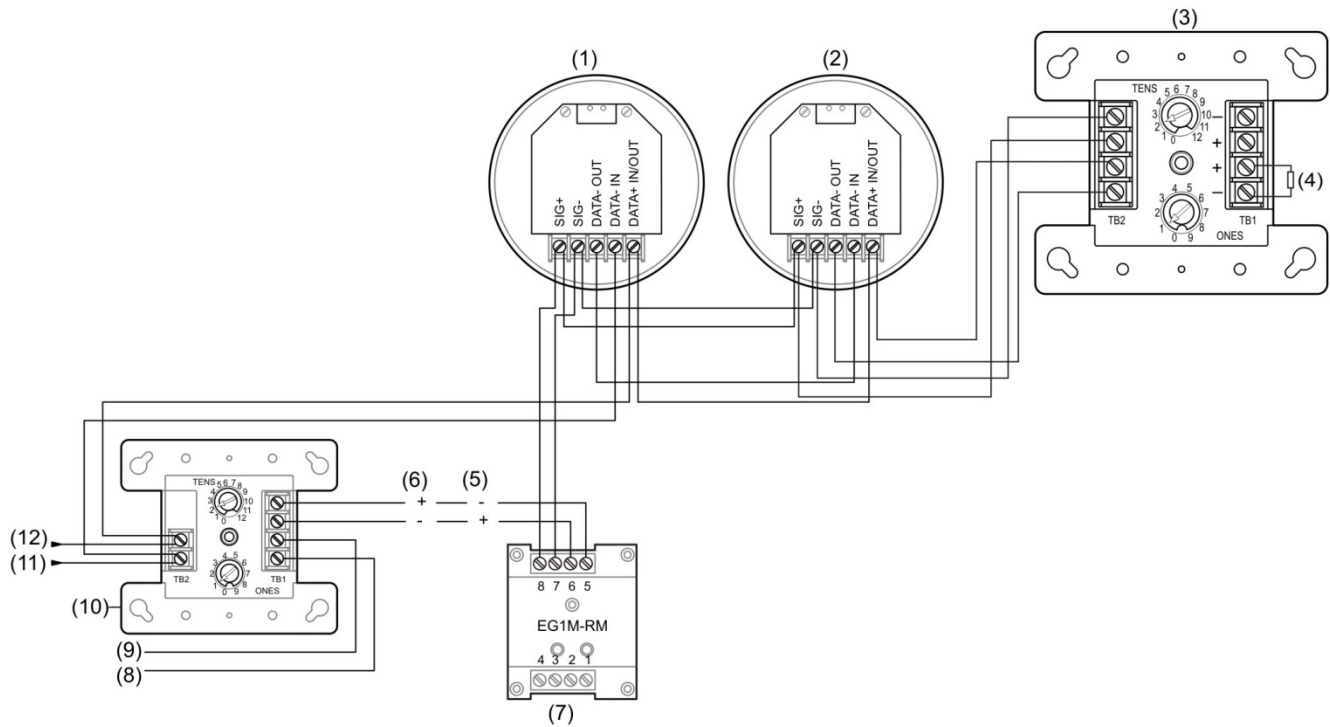

- | | |
|-----------------------------------|------------------------|
| (1) First detector (sounder base) | (7) EG1M-RM module |
| (2) Last detector (sounder base) | (8) AUX riser 24 VDC - |
| (3) FX-NAC | (9) AUX riser 24 VDC + |
| (4) 47 kΩ EOLR | (10) FX-RLY |
| (5) Active | (11) SLC IN - |
| (6) Normal | (12) SLC IN + |

Note: The EG1M-RM module is required to provide sounder synchronization.

Programming sounder bases for a local alarm signaling application

Note: For PD, PHD, and PDD detectors configured as “Supervisory Non-latching” device type or for PCD detectors (smoke element) configured as “Smoke Supervisory Non-latching” device type, if the base is Relay/Sounder, then the follow type option cannot be configured as “Head.” The follow type in this case should be set to “Alarm.”

To program sounder bases for local alarm signaling:

1. Set the panel’s Event Notification option to Device.
2. Configure the smoke detectors as follows:
 - Message Line 1: Description of the installed detector location
 - Base: Sounder
 - Follow: None, Alarm, Alm + Vrfy, or Alm + PreAlm
3. Configure the RLY module as follows:
 - Device Type: Relay Silence
 - Message Line 1: SOUNDER_RLY_1
4. Configure the FX-NAC module as follows:
 - Device type: Supervised Output
 - Message Line 1: 24VDC_RISER
 - Message Line 2: SOUNDER_RLY_1
5. Configure Correlation 001 as follows:
 - Add/Remove Device: All alarm signal-initiating devices
 - Add/Remove NAC: All RLY modules used to active sounder bases

SA-FSB Building Management System Communication

You can configure your FX system to communicate with a building management system by using an SA-FSB Communication Bridge. The SA-USB is an ancillary device that provides a communication bridge between an FX systems and a building management system (BMS) by converting the FX control panel External Communications Protocol into supported serial and Ethernet protocols. The communication bridge operates over RS-232 serial communications.

The communication bridge mounts on a separately ordered bracket (FSB-BRKT2) that can be installed in an MFC-A external enclosure. You can configure your system for communication between a same BMS and a single FX control panel or multiple control panels in your network. See *SA-FSB Communication Bridge Installation Sheet* (P/N 3102662) for application details, as well as installation instructions and specifications.

KESMobile and Web Portal System

The system is composed of a cloud platform, web portal, a mobile application, and a panel provisioning tool to facilitate communication with the panel over the internet.

The system allows monitoring of the FX fire panel by gathering information from the panel and transmitting this information to the cloud.

The cloud based application is iOS, Android, and Web Browser compatible to receive push notifications from live system activity on the FX panel remotely. The remote connectivity allows for communication back to the FX panel for diagnostics, troubleshooting, and generating system reports.

The mobile application is available for download from the respective application stores.

For detailed information about the KESMobile and Web Portal System and the panel provisioning tool, refer to the following.

- *KESMobile and Web Portal User Guide* (P/N 3102759)
- *KESMobile and Web Portal Installation Manual* (P/N 3102760)
- *Panel Provisioning Tool Help*

In-suite signal silence applications

This section provides high level instructions for creating an in-suite signal silence application based on the use of correlation groups. Additional background material and detailed instructions are also available. See:

- “What is in-suite signal silence?” on page 41
- “Programming in-suite signal silence” on page 90
- “What is a correlation group?” on page 39
- “Correlation group programming” on page 85

Figure 64: Building with a separate audible circuit for each floor and separate circuits for audibles within and not within dwelling units

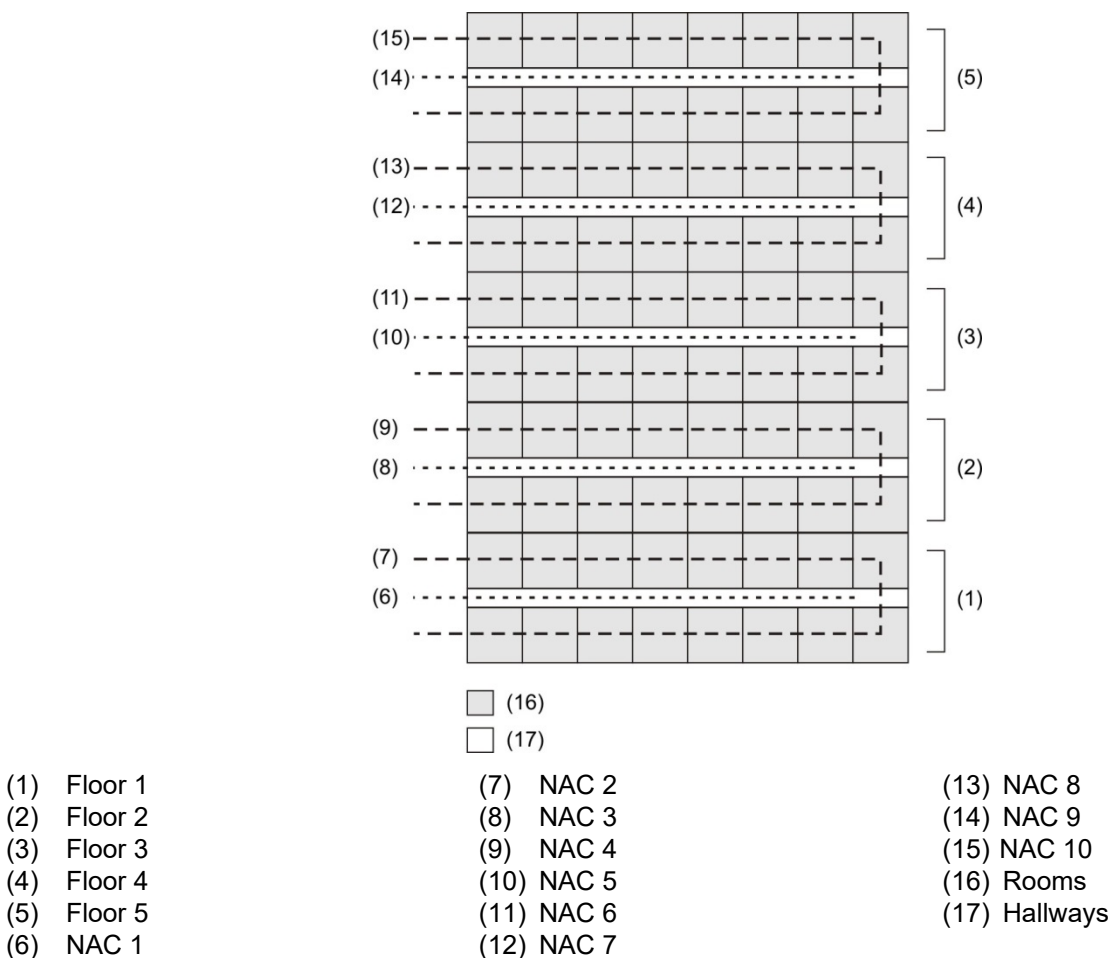

Wiring

In-suite signal silence applications in residential occupancy buildings require separate signal circuits for each floor area. In addition, each floor area requires separate circuits for:

- Audible devices located within-suites or dwelling units
- Audible devices *not* located within-suites or dwelling units

Figure 64 on page 243 illustrates these requirements in a sample residential occupancy building with five floors. The illustration shows that:

- Separate audible signal circuits are provided for each floor
- Audible signal circuits 2, 4, 6, 8, and 10 are located inside dwelling units
- Audible signal circuits 1, 3, 5, 7, and 9 are located in hallways *not* within dwelling units.

Correlations

To enable in-suite auto signal silence, you need at least 'N+2' correlation groups, where N = the number of floor areas. You need: A correlation group for each floor, a hallway correlation group, and an "in-suite" correlation group. The following tables show the inputs and outputs for these groups.

To create correlations for in suite signal silence:

1. Create a set of correlations for each floor.
2. Create a single hallway correlation to control hallway sounders on all floors.
3. Create a single in-suite correlation for all floors to turn off sounders inside dwelling units on all floors except the floor of alarm.

Details of each step are described below.

Creating a set of correlations for each floor

Referring to the tables below, create a set of correlations — one for each floor. While the example given here is for a five-story building, you can adapt it to fit the number of separate floors (or other areas) in your application. Create one correlation for each floor (or area). These correlations ensure that if an alarm is detected on the floor, sounders located in dwelling units on the same floor will sound.

On each floor, link all input devices on the floor (both inside dwelling units and in hallways) to the sounders inside dwelling units on the same floor.

Notes

- Set the alarm activation count for each floor correlation to 1.
- Do not enable in-suite signal silence.

Floor 1 Correlation

Input	Output	No in-suite signal silence
Floor 1 dwelling and hallway inputs	Floor 1 dwelling and hallway audibles	

Floor 2 Correlation

Input	Output	No in-suite signal silence
Floor 2 dwelling and hallway inputs	Floor 2 dwelling and hallway audibles	

Floor 3 Correlation

Input	Output	No in-suite signal silence
Floor 3 dwelling and hallway inputs	Floor 3 dwelling and hallway audibles	

Floor 4 Correlation

Input	Output	No in-suite signal silence
Floor 4 dwelling and hallway inputs	Floor 4 dwelling and hallway audibles	

Floor 5 Correlation

Input	Output	No in-suite signal silence
Floor 5 dwelling and hallway inputs	Floor 5 dwelling and hallway audibles	

Creating a hallway correlation

The hallway correlation ensures that an alarm detected anywhere in the building will turn on all audibles located in hallways throughout the building.

On the input side of this correlation, add all input devices on all floors. Include all those inside dwelling units and all those in hallways.

On the output side, add all hallway sounders throughout the building.

Notes

- Set the alarm activation count for this correlation to 1.
- Do not enable in-suite signal silence.

Hallway Correlation

Input	Output
Occupant and hallway inputs on all floors	Hallway sounders on all floors

Creating an in-suite correlation group

The in-suite correlation is used to silence sounders inside dwelling units, except on the floor of alarm.

Create one in-suite correlation group. On the input side, add all input devices on all floors. Include those located inside dwelling units and those located in hallways.

On the output side, add all sounders located inside dwelling units on all floors.

Notes

- Set the alarm activation count for this correlation to 1.
- For this correlation only, enable in-suite signal silence.

In-Suite Signal Silence Correlation

Input	Output
Occupant and hallway inputs on all floors	Occupant sounders on all floors

How this application works

This application silences the audible alarm signals inside dwelling units, except on the floor of the alarm.

For example, if an alarm occurs on the third floor:

- The Floor 3 Correlation turns on the sounders on the floor of the alarm (including those inside dwelling units).
- The Hallway Correlation turns on hallway sounders throughout the building.
- The In-Suite Signal Silence Correlation turns on sounders in residences on all other floors.
- After 60 seconds, the In-Suite Signal Silence Correlation, which has in-suite signal silence enabled, silences sounders inside dwelling units on all other floors. These signals remain off until the in-suite signal silence timer expires or a subsequent alarm comes in.

Index

A

AC

- fail delay, 37, 120
- failure delay, 44
- power, 140
- power wiring, 6
- voltage, 6, 120

account ID, 107, 117

ACK/Panel Silence, 142, 158

- button, 142

activating

- devices, 160
- NACs, 161

activation count, 87

adding devices, 81

addressable device loop wiring, 12

advanced programming, 42, 83, 84

alarm

- contact, 196
- device, 52, 194
- event, 129
- history report, 177
- LED, 140

alphanumeric keypad, 42

annunciator

- buzzer, 158
- channel wiring, 19
- class, 44, 103
- event, 136, 149
- programming, 103
- specifications, 18
- type, 44, 103

appliance and cable values, 205

applications

- ULC-S559, 230

Arrow button, 42

auto programming, 41, 69

- options, 70
- panels, 74

auto signal silence, 44, 120, 158, 159

auto zoning, 70

automatic zone assignment, 41

aux power reset, 44

auxiliary

- current, 196
- fire alarm system, vii
- output wiring, 20

B

backbox

- installation, 2
- panel, vii
- wire routing, 5

backlight, 136

banner screen, 120, 136

battery

- calculation worksheet, 200
- location, 8
- specifications, 196
- wiring, 8

BMS, 242

building management system. See BMS

buttons

- Arrow, 42
- Cancel, 42, 144
- Enter, 42
- Menu, 42
- Space, 144
- Symbol, 144

C

calculating cable length, 208

call disconnect, 107, 117

callback, 107, 117

Cancel button, 42, 144

capturing reports, 194

central station, vii

changing passwords, 63

CID codes, 49, 107, 117, 123, 127

circuit specifications, 13, 24, 27

city tie

- module, 31
- NACs, 170

- Class A, 10, 29
 - Class A and Class B circuit specifications, 13
 - Class A circuit specifications, 18
 - Class B, 10
 - Class B circuit specifications, 18
 - cleaning detector, 186
 - clearing history, 68
 - CMS
 - device, 44, 104, 170
 - network transmitter, 109, 110
 - coder, 100
 - comm retries report, 181
 - common trouble, 131
 - event, 86
 - communication
 - check, 187
 - fault, 187
 - communication bridge, 242
 - communications fault, 82
 - configuration utility, 69, 119
 - contact ID codes, 49, 123, 127
 - continuous circuit, 20
 - control buttons, 42, 142
 - control panel, 135
 - operations, 135
 - specifications, 196
 - testing, 188
 - correlated zone application, 237
 - correlation group, 92, 98, 100, 131
 - activation count, 87
 - adding members, 85
 - configuration report, 179
 - copy members, 87
 - fast group, 90
 - loop settings, 47
 - programming options, 79, 85
 - removing members, 88
 - reports, 179
 - sounder base detectors in, 90
 - what is, 39
 - worksheet, 218
 - correlations, 244
 - cross zoning, 87
 - CTM module wiring, 31
 - cut duration, 37, 107, 117
- D**
- D16L-Fa LED, 141
 - DACR, 30
 - date, 136
 - format, 44, 120
 - forward history report, 177
 - date, setting, 61
 - day
 - sensitivity, 92
 - start, 44, 120
 - daylight saving time, 44, 62
 - sample values, 62
 - default
 - loop configuration, 47
 - passwords, 43
 - programming options, 63
 - settings, 63
 - deleting devices, 82
 - detector cleaning, 186
 - device
 - activation, 160
 - communication, 181
 - correlation groups, 85, 92
 - count, 181
 - disabling, 165
 - enabling, 165
 - event, 150
 - label, 92, 136
 - labeling, 75, 78
 - maintenance report, 178
 - number, 136
 - polling, 181
 - programming, 92
 - removing, 82
 - reporting, 107, 110, 117, 120, 180
 - restoring, 160
 - settings worksheet, 219
 - testing, 171, 189, 191
 - type, 92
 - device address assignment, 13
 - device details, 82
 - accessing, 136
 - report, 181
 - device loop, 97, 98
 - maximum wire length, 214
 - specifications, 196
 - device type, 47, 52
 - alarm, 52
 - input module, 58
 - latched output, 60
 - monitor, 59
 - output, 59
 - supervisory, 59
 - trouble, 59
 - diagnostics
 - fast ground check, 186
 - loop comm check, 187
 - recalibrate device, 186
 - reports, 181
 - dialer, 70, 104, 107, 117
 - configuration, 107, 117
 - configuration report, 180
 - disabling, 170
 - enabling, 170

- line 01 and 02, 107, 117
- mode, 37
- testing, 190
- type, 107, 117
- dialer programming, 109
- dirty percentage, 178
- disable
 - devices, 165
 - dialers, 170
 - events, 167
 - LED, 140, 165, 170
 - loop events, 168
 - NACs, 170
 - network card, 170
 - zones, 166
- disable/enable panel NAC, 170
- disabled points, 136, 165
- Down Arrow button, 144
- downloading, 69
- drill, 171
- dual line, 107, 117
- duct
 - alarm, 58
- duct supervisory, 59

E

- enable
 - devices, 165
 - dialers, 170
 - events, 167
 - in-suite signal silence, 90
 - loop events, 168
 - NACs, 170
 - network card, 170
 - RS232 communication, 69
 - zones, 166
- enable/disable panel NAC, 170
- end a walk test, 173
- Enter button, 42
- equation method, 208
- Ethernet
 - card, 30
 - wiring, 30
- event
 - annunciator, 149
 - codes, 49, 127
 - configuration report, 180
 - details, 136, 156
 - disabling, 167
 - enabling, 167
 - history log, 68
 - ID numbers, 151
 - notification, 44, 92, 120
 - off-normal, 136
 - programming, 123, 129

- reporting, 107, 110, 117
- type, 136
- event messages, 148
- expanders, 103

F

- factory default settings, 43
- fast ground check, 186
- fast group, 90
- fire drill, 171
- firmware, 68
- firmware revision, 180
- firmware update utility, 68
- flash device LED, 187
- follow option, 70, 92
- front panel display, 135
- function keys, 65
- FUU, 68

G

- gateway, 44
- Genesis NAC, 100
- ground fault, 186
 - impedance, 13, 18, 20, 29, 197
 - LED, 140
- ground wire, 6, 7

H

- hello time seconds, 110
- history
 - log, 68
 - report, 176
- HyperTerminal, 193

I

- image select, 68
- incremental programming, 42, 76, 77
- initiating a fire drill, 171
- input module device type, 58
- installing
 - panel backbox, 2
- in-suite signal silence, 41, 90
 - application, 243
 - elapse timer, 90
- internal
 - event, 136, 149
 - fault report, 183
 - status report, 181
- IP address, 44, 110
- isolators, 196

K

KESMobile and web portal system, 242
keys. See programmable keys

L

label, 136
 annunciators, 103
 device, 92
 devices, 70, 75, 78
 NACs, 100
 zones, 70, 75, 78, 98
lamp test, 159, 191
 button, 159
Lamp Test button, 142
language, 44, 120
latched output
 device type, 60
 restore, 161
latching, duct supervisory, 59
LCD
 banner, 44, 120
 display, 103, 135, 136
LEDs, 30, 135, 140
 loop card, 15
 zone designation, 141
Left Arrow button, 143
line number, 110
LNI2000, 230
LNS2004, 230
LNS2008, 230
load factor, 205
lock remote read, 44, 119
loop
 card LEDs, 15
 circuit, 84, 97, 98, 196
 class, 47, 98
 comm check, 187
 configuration options, 84, 85, 92, 98
 enabling, 47
 event enabling/disabling, 168
 events, 127, 129
 fast group, 47
 fault, 127
 programming, 83
loop-zone configuration report, 180
low voltage wiring, 7

M

mains supply, 6, 120
maintenance schedule, 186
marketplace, 44, 120
Menu button, 42, 143
minimum voltage, 205

modem, 107, 117
monitor device type, 59

N**NACs**

 activation, 161
 enabling/disabling, 170
 modules, 60
 non-silenceable, 159
 programming, 100
 restoring, 161
 silencing, 159
 type, 100
 wiring, 10, 29
 wiring location, 11
network, 44, 104, 110
 cable, 30
 card, 30
 card disable, 170
 wiring, 30
night
 sensitivity, 92
 start, 44, 120
nonlatching, duct supervisory, 59
nonpower-limited wiring, 5
normal mode, 135
notification appliance, 158
 circuit, 170, 196
 wiring, 10
 worksheet, 205, 211
number expanders, 103

O

off-normal, 135, 137
operating current, 29, 196
operation overview, 135
output device type, 59

P**panel**

 auto programming, 74
 backbox, vii, 5
 buzzer, 158
 configuration options, 107, 110, 116, 117, 119
 configuration report, 180
 event programming, 123
 events, 167
 installation, 2
 NAC, 10, 29, 44, 170
 programming, 69, 83
 reset, 157
 restarting, 68
 silence, 158

- wire routing, 5
- panel configuration
 - options, 100, 103, 104
 - worksheet, 223
- panel operation
 - options, 120, 135
 - programming, 120
 - report, 180
 - worksheet, 226
- passwords, 63
- photo detector, 56
- ping, 119
- power
 - LED, 140
 - type, 205
- power supply values, 205
- power-limited wiring, 5
- prealarm, 92
- preventive maintenance schedule, 186
- primary receiver number, 107, 117
- print reports, 176
- printer
 - programming, 116
 - type, 44
 - wiring, 24
- program
 - annunciators, 104
 - button function priority, 146
 - CMS devices, 104
 - command buttons, 38
 - common trouble event, 131
 - control buttons, 42
 - correlation groups, 85
 - defaults, 63
 - events, 84
 - in-suite signal silence, 90
 - loop events, 127, 129
 - loop options, 83
 - menu, 61
 - modes, 38, 41
 - NACs, 102
 - panel options, 83
 - requirements, 37
 - unconfigured alarm events, 130
- program a printer, 116
- program panel events, 127
- program panel operation, 120
- program the CMS
 - network, 109, 115
- program the dialer, 109
- programmable keys, 64, 65, 145
- Proprietary signal receiving center, 230, 232
- protected premises fire alarm system, vii
- pull station, 58

Q

- quality percent, 181

R

- recalibrate device, 186
- receiver number, 110
- receivers, 30
- redundant Class B, 29
- relay specifications, 196
- remote
 - annunciator, 18, 103, 196
 - annunciator wiring, 29
 - communications, 119
 - disconnect, 170
 - disconnect LED, 140
 - drill, 58
 - signal silence, 58
 - supervising station, vii
- Remote Disconnect button, 142
- removing devices, 82
- replacing a device in alarm, 194
- reports, 176, 183, 194
 - alarm history, 177
 - canceling, 183
 - communication retries, 181
 - correlation group configuration, 179
 - correlation groups, 179
 - date forward history, 177
 - device details, 181
 - device maintenance, 178
 - diagnostics, 181
 - history, 176
 - internal fault, 183
 - internal status, 181
 - response quality, 182
 - system configuration, 180
 - system status, 178
 - walk test, 177
 - zone, 180
- reset
 - inhibit, 44, 120
 - panel, 157
- Reset button, 142
- resettable circuit, 20
- response quality report, 181, 182
- restart panel, 68
- restorals, 110
- restore
 - codes, 37
 - defaults, 63
 - devices, 160
 - latched output, 161
 - NACs, 161
- retry

- count, 107, 117
- time, 107, 117
- Return button, 144
- revision, 180
- Right Arrow button, 142, 143
- ring type, 107, 117
- rings to answer, 107, 117
- RPM module wiring, 33
- RS-232, 193
- RS232 CU Enable, 44, 69
- RZI
 - 24V IN maximum wire run calculation worksheet, 213

S

- SA-232
 - terminals, 24
 - wiring, 24
- SA-CLA wiring, 29
- SA-DACT, 190
 - specifications, 196
 - wire location, 22
 - wiring, 21
- SA-ETH
 - LEDs, 30
 - wiring, 30
- SA-FSB, 242
- SB4U, 233, 238
- secondary receiver number, 107, 117
- semi-flush mount panel installation, 2
- send restorals, 107, 110, 117
- sensitivity
 - day/night, 92
 - report, 178
- serial numbers, 181
- set activation count, 87
- shutdown period, 41
- signal
 - synchronization, 13
- Signal receiving center, 230, 231
- signal silence, 58, 158
 - button, 142
 - LED, 140
- silencing
 - annunciator buzzer, 158
 - NACs automatically, 159
 - notification appliances, 158
 - panel buzzer, 158
- single line, 107, 117
- smoke power auxiliary power location, 21
- sounder base, 233, 238
 - detectors, 90, 238
 - fast groups, 90
- source voltage, 205
- Space button, 144

- specifications
 - auxiliary/smoke power output, 20
 - battery, 196
 - control panel, 196
 - device loop, 196
 - NAC, 10
 - relays, 196
 - remote annunciator, 18, 196
- standalone, 44
- standalone mode, 120
- start a fire drill, 171
- start a walk test, 173
- subnet mask, 44
- suite signal silence, 44, 159
- supervisory
 - contact, 196
 - LED, 140
- surface mount panel installation, 2
- swinger shutdown, 44, 104
- Symbol button, 144
- system
 - alarm signaling application, 237, 239
 - configuration report, 180
 - events, 156
 - LEDs, 135, 140
 - requirements, vii
 - status report, 178

T

- TB1, 7
- TB2, 10
- TB3, 20
- TB4, 18
- TB6, 10
- TB8, 8
- TCP/IP
 - communications, 119
 - port, 110
- telephone supervision, 37
- telnet, 119
- temporal, 100
- test fire, 189
- test signal frequency, 37
- testing
 - control panel, 188
 - devices, 189
 - dialers, 190
 - LEDs, 140
- time and date, setting, 61
- timeout seconds, 110
- tone wait, 107, 117
- transformer location, 7
- transformer wiring, 7
- trouble, 131
 - contact, 196

device type, 59
LED, 140, 165, 170

U

UL/ULC programming requirements, 37
ULC testing, 188
unconfigured
 events, 130
unconfigured alarm, 129
unlatching output devices, 161
unprogrammed device, 79
Up Arrow button, 142, 143
uploading, 69
user defined keys, 64

V

view
 event details, 139, 156
 reports, 176
voltage drop, 205
voltage drop calculation worksheet, 211

W

walk test, 171, 191
 report, 177
waterflow, 58, 98
waterflow no delay, 58
waterflow no delay class A, 58
wire
 length calculation, 205, 214
 resistance, 208
wire routing, 5
wiring
 AC power, 6
 annunciator channel, 19

auxiliary/smoke power output, 20
batteries, 8
CTM module, 31
notification appliance circuit, 10
printer, 24
remote annunciator, 18
RPM module, 33
SA-232, 24
SA-DACT, 21

worksheet method, 207

worksheets

 battery calculation, 200
 correlation groups, 218
 device loop maximum wire length, 214
 device settings, 219
 loop, 222
 notification appliance, 205
 panel configuration, 223
 panel operation, 226
 RZI 24V IN maximum wire run calculation, 213
 voltage drop, 211
 zone setting, 227

Z

zone, 47
 correlation groups, 85
 description, 38
 enable/disable, 166
 event, 136, 150
 labeling, 75, 78
 programming, 79, 98
 report, 180
 reporting, 107, 117, 120
 resound, 44, 120
 settings worksheet, 227
 testing, 171, 191

