



Product Data Sheet

1085W-N

Surface mount contact with wire leads

Sentrol 1085 series

The Sentrol 1085 series surface mount magnetic contacts are designed for use in installations where a small, sealed unit is required. The reed switch is totally encapsulated in Sentrol's exclusive polyurethane potting compound preventing moisture from entering the switch and causing false alarms.

Easy installation

The 16 mm standard gap distance allows for fast, easy installation and prevents false alarms from loose fitting doors. Recessed mounting holes make for clean-looking installations.

High Quality components and materials

Reed legs are plated with rhodium or ruthenium, and hermetically sealed in dry nitrogen. This offers superior protection against sticking and provides a moisture free environment therefore preventing corrosion.



Standard Features

- Convenient surface mounting
- Mounting screws included
- Neat and tidy design
- Comprehensive product range

1085W-N

Surface mount contact with wire leads

Specifications

Gap distance (max)	38 mm
Connections	30 cm wire leads
Contact	NC
Supervised loop	No
Dimensions (L x W x H)	51 x 9,5 x 9,5 mm
Color	White

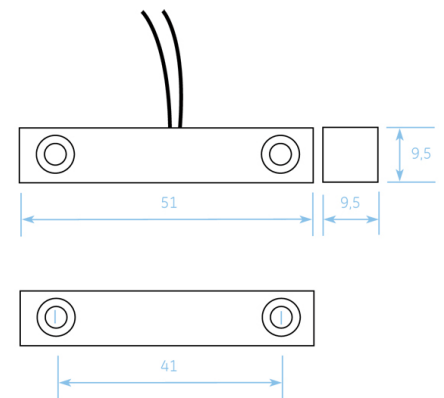

Ordering Information

Part No.	Description
1085W-N	Surface mount contact with wire leads, wide gap, white

