

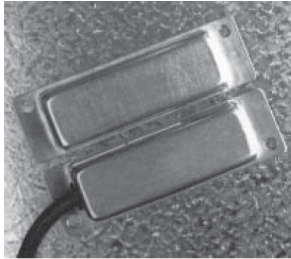

# GuardSwitch Series 300 Safety Interlock Switch 391-BT and 393-BT Installation Sheet



## Description

The GuardSwitch Series 300 Safety Interlock Switch, models 391-BT and 393-BT DPST (double pole single throw) are designed for use with safety monitored relays or monitored circuits. To achieve the optimum defeat resistance features of the switch, both the switch circuit (Circuit 1) and the tamper circuit (Circuit 2) must be connected. An optional third circuit can be provided to indicate at the panel which guard is open.

## Notes

- Environmental: Pollution Degree II.
- Correct use of this control device is an essential part of proper machine cycle control.
- Failure to follow *all* instructions could lead to serious bodily injury or death.
- Maintenance to be done by qualified personnel only.
- The connecting cables between the INT devices and the switches must be located in an IP 23 type enclosure (minimum).
- The mounting for the switch and the actuator magnet must be accomplished per this specification.
- Nonremovable hardware must be used for installation.
- The housing of the switch must be connected to the PE (primary earth) ground circuit via a lock washer on the mounting screw. The PE ground symbol must be placed adjacent to the screw.

## To verify switch operation with an ohmmeter:

Set range at 20 MΩ (switches with triac output, set range at 20 kΩ). For a normally open switch, the meter will read a high impedance with the actuator away. It will read very high to infinity range (triac switches will read high kilo ohm to infinity range) with the actuator within sense range. You will see the opposite reading for a normally closed switch.

## Installation

Use nonremovable screws, bolts, or nuts to mount the switch and actuator. Do not over-torque mounting hardware. See Figure 1 for dimensions.

**Caution:** When used without a Sentrol INT relay, particular care must be taken to determine the actual load of the switch circuit. High voltage transients from coils, motors, contactors, and solenoids must be considered. Transient protection, such as back-to-back zener diodes (TransZorb) or an RC network, is recommended for such loads to ensure that maximum ratings of the switch are not exceeded. Not recommended for use with tungsten filament loads because of high current inrush surges. Line capacitance and load capacitance must be considered.

Excessive line capacitance can be caused by cable lengths over 50 ft. when using a maximum 48 VAC. A resistor can be added in series to limit the inrush current (at least 48 Ω for 24 V applications).

The resistor can be added in series just before the load.

The voltage drop and the power rating of the resistor must be considered.

$$\text{Voltage drop} = I \times R$$

$$\text{Wattage} = I^2 \times R \quad (I = \text{maximum continuous current of the load})$$

## To install the switch:

1. Position the switch and actuator so the labels are reading in the same direction (see Figure 2).
2. Mount the switch on the stationary frame of the machine and mount the actuator on the moveable guard, door or gate. Keep the switch and actuator within the listed sense range. See "Ordering information" on page 4 for sense ranges. See Figure 3 for recommended mounting configurations.
3. Mounting on a ferrous material will affect the sense range a minimum of 50%. However, a 1/4 in. nonferrous spacer positioned under the magnet and/or switch should restore most of the lost sense range.
4. For best protection against operator defeat, mount with nonremovable screws, bolts or nuts. See ordering information for details.
5. When mounting the switch on an ungrounded machine, ground the switch housing by connecting your ground lead to one of the switch mounting screws.

## Mounting configurations

The interlock switch and actuator magnet should be mounted in only three configurations for actuation. See Figure 3.

Three configurations are appropriate for safety interlock applications. The parallel actuation can result in on/off/on signal if the actuator passes by the switch rather than coming to rest in proximity to it. This is *not* a recommended configuration for safety interlock applications.

Figure 1: Dimensions

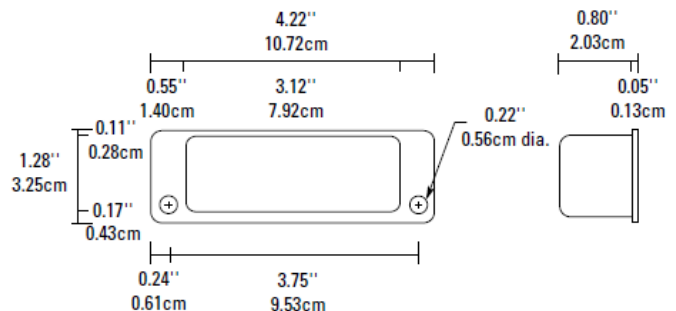

**Figure 2: Switch/actuator position**

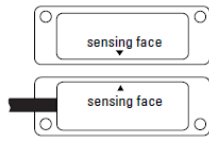

**Figure 3: Mounting configurations**

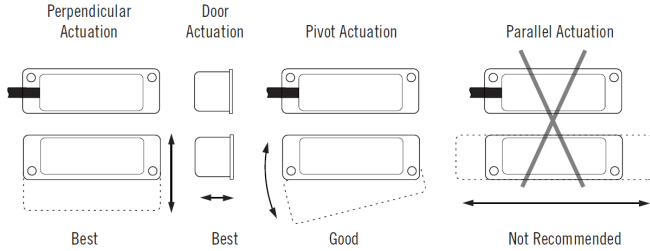

**Figure 4: Circuits**

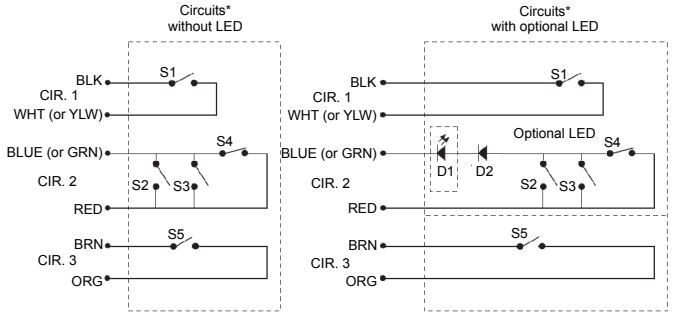

\*Circuits shown with actuator away from switch.

S1, S5	Normally open reed switch, closed when actuator is within 0.6 in.
S2, S3	Normally open reed switches, will close if misaligned or tampered with a standard magnet
S4	Biased closed reed switch, open when actuator is between 0.3 in. and 0.6 in.
NO circuit	Black, white, or yellow wires.
NC biased tamper circuit	Red, blue, or green wires.
NO monitor circuit	Orange and brown wires.

**Note:** For white and blue colors, see the optional color codes shown in Figure 4.

**Figure 5: Wiring for category 3**

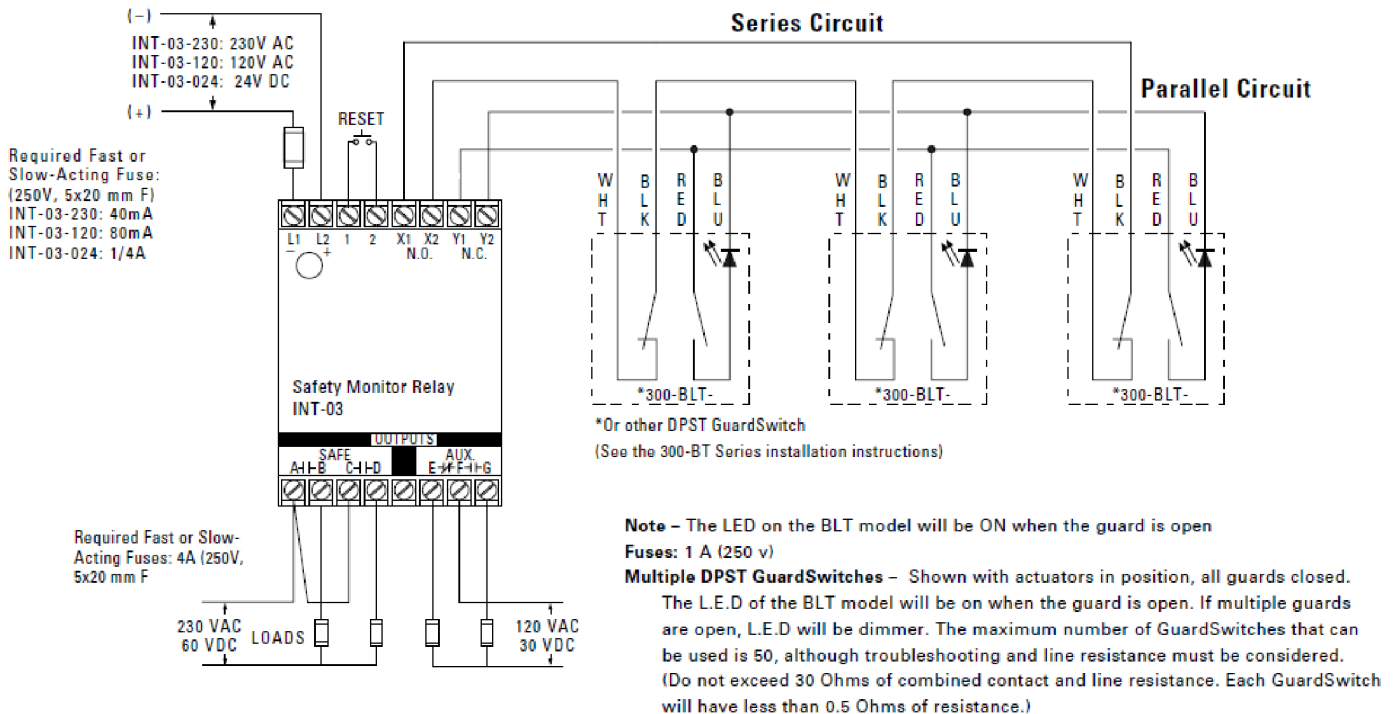

**Note:** For white and blue colors, see the optional color codes shown in Figure 4.

Figure 6: Wiring for category 4

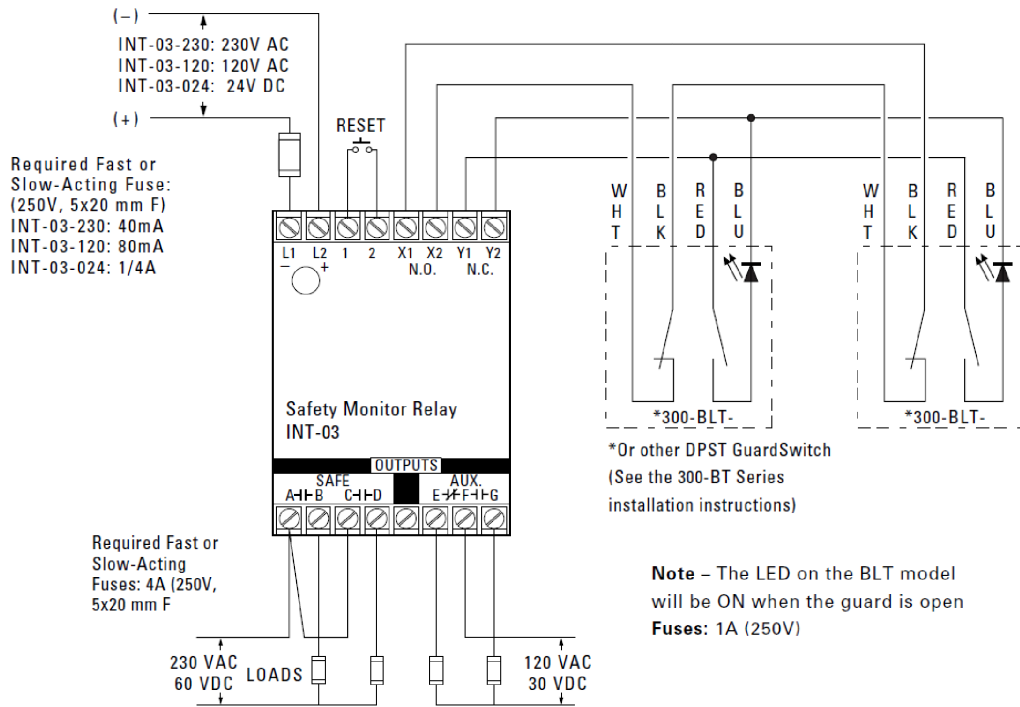

Note: For white and blue colors, see the optional color codes shown in Figure 4.

Inputs shown with safety gate/guard in closed position. Two Series 300-BT GuardSwitches with one INT relay are required for each safety gate. When first applying the INT Safety Monitor Relay, the inputs must be cycled to check for proper operation before the output contacts close. To cycle the inputs, the guard must be opened and then closed. This start-up test is sufficient; however, we recommend that the proper operation of the switches and relay be checked at least every 24 hours.

## Specifications

### General specifications

Enclosure	Seamless 304 stainless steel
Temperature range	-40°F to 180°F (-40°C to 80°C)
Environmental	Hermetically sealed contact switch, encapsulated in polyurethane
NEMA rating	1, 2, 4, 4X, 5, 12, 12K
Protection class	IP 67
Response time	1 msec
Individual circuits	The two circuits do not switch simultaneously, and depend on the speed of the guard closure. Based on closure speed of 1 ft. per second and a gap of 1/8 in., a delay less than 50 msec is typical.
Life cycles	100,000 under full load Up to 200,000,000 under dry circuit
Lead types/O.D.	18/4 SJTOW (K) / 0.34 in. (0.86 cm) 22/4 PVC Jacketed (J) / 0.19 in. (0.48 cm) 22/6 PVC Jacketed (J) / 0.21 in. (0.53 cm)

For additional options and alternate specifications, consult factory.

### Accessories

Part number	Tamper proof screws and screwdriver
1953	#6 x 3/4 in. L Tampruf Roundhead Screw
1954	#8 x 1-1/2 in. L Tampruf Roundhead Screw
1955	Tampruf Screwdriver
1956	Tampruf 1/4 in. Drive Bit for #6 and #8 screws

## Electrical specifications [1]

Circuit number	Circuit type	Contact configuration	Load rating	Switching voltage	Switching current
1	Switch: S1	NO	40 W/VA	48 VAC/VDC	1.0 ADC, 0.7 AAC
2	Tamper: S2, S3, S4	NC	10 W/VA	48 VAC/VDC	0.2 A
2	With optional LED: D1	NC	0.1 to 1.4 W	48 VDC(3 V drop)	30 mA
3	Monitor: S5	NO	10 W/VA	48 VAC/VDC	0.3 ADC, 0.3 AAC

[1] IMPORTANT: Each electrical rating is an individual maximum and cannot be exceeded.

## Ordering information

Part number [1]	Contact configuration [2]	Sense range minimum [3]	Sense range maximum [3]	Break range	Lead length nominal
391-BT-06(J)(K)	DPST: 1 NO, 1 NC	0.3 in.(0.8 cm)	0.6 in.(1.5 cm)	1.2 in.(3.0 cm)	6 ft. (1.8 m)
391-BT-12(J)(K)	DPST: 1 NO, 1 NC	0.3 in.(0.8 cm)	0.6 in.(1.5 cm)	1.2 in.(3.0 cm)	12 ft. (3.6 m)
391-BLT-06J	DPST: 1 NO, 1 NC w/LED	0.3 in.(0.8 cm)	0.6 in.(1.5 cm)	1.2 in.(3.0 cm)	6 ft. (1.8 m)
391-BLT-12(J)(K)	DPST: 1 NO, 1 NC w/LED	0.3 in.(0.8 cm)	0.6 in.(1.5 cm)	1.2 in.(3.0 cm)	12 ft. (3.6 m)
391-B3LT-12J	TPST: 2 NO, 1 NC w/LED	0.3 in.(0.8 cm)	0.6 in.(1.5 cm)	1.2 in.(3.0 cm)	12 ft. (3.6 m)
391-B3LT-20J	TPST: 2 NO, 1 NC w/LED	0.3 in.(0.8 cm)	0.6 in.(1.5 cm)	1.2 in.(3.0 cm)	20 ft. (6.1 m)
393-BT-06(J)(K)	DPST: 1 NO, 1 NC	0.3 in.(0.8 cm)	0.6 in.(1.5 cm)	1.2 in.(3.0 cm)	6 ft. (1.8 m)
393-BT-12J	DPST: 1 NO, 1 NC	0.3 in.(0.8 cm)	0.6 in.(1.5 cm)	1.2 in.(3.0 cm)	12 ft. (3.6 m)
393-BLT-12K	DPST: 1 NO, 1 NC w/LED	0.3 in.(0.8 cm)	0.6 in.(1.5 cm)	1.2 in.(3.0 cm)	12 ft. (3.6 m)

[1] The part numbers 391 and 393 are the same in all respects except for the cable exits; 391 left and 393 right.

[2] Configuration with actuator away from the switch.

[3] Proximity of ferrous materials usually reduces sense range — typically by 50%. The shape and type of material cause a wide diversity of effects. Testing is required to determine actual sense range for specific applications.

## Regulatory information

Model number	UL	CSA
391-BT-06(J)(K)	X	X
391-BT-12(J)(K)	X	X
391-BLT-06(J)	X	X
391-BLT-12(J)(K)	X	X
391-B3LT-12(J)	X	
391-B3LT-20(J)	X	
393-BT-06(J)(K)		
393-BT-12J		
393-BLT-12K		
UL file number	E122942	
CSA file number	089176	

## Contact information

For contact information, see [www.edwardsfiresafety.com](http://www.edwardsfiresafety.com).

© 2015 Walter Kidde Portable Equipment, Inc.

All rights reserved.