



869DSTR*-G1 Diode Polarized Electronic Horn-Strobe Installation Sheet

Description

The horn-strobes are UL and cUL Listed, high-quality, diode polarized signals intended for use in general signaling applications. The strobes flash at 1 fps across their full operating voltage range.

It is recommended that these products be installed in accordance with the requirements in the latest edition of national and local electrical codes.

Table 1: Models

Description	Numbers
Horn/Strobe, Gray, Flush or Panel Mount, Indoor	869DSTR*-G1

*Insert lens color: C - clear, R - red, G - green, B - blue or A - amber

Installation

WARNING: To reduce the risk of shock, always disconnect all power before handling the unit.

WARNING: To reduce the risk of shock, do not tamper with this device when the signal circuit is energized. Disconnect all power and wait 5 minutes for stored energy to dissipate before handling.

1. Select mounting method as detailed in Figure 1 on page 2 and install the electrical box (not supplied) using suitable hardware.
 - a. For outdoor applications, install the weatherproof box (ordered separately) using four #10 x 1 1/4" (32 mm) screws and cap lugs provided in the enclosed parts bag.

Note: Be sure hook flange is facing outward as shown in Figure 1 on page 2.

Note: The designation "TOP" on boxes denotes orientation of box after installation.

2. Attach mounting plate using two #8-32 screws provided with the surface box (ordered separately) or four #8-32 screws provided with the weatherproof box (ordered separately). The flush box uses two #8-32 screws (not provided).
3. Bring signaling circuit field wiring into electrical box.

4. Ground in accordance with national and local electrical codes. A green ground screw is provided with both the indoor and outdoor surface boxes.
5. Connect signaling circuit field wires to terminals on horn/strobe assembly (Figure 2 - 4 on page 2).
6. Mount the horn/strobe assembly on the mounting plate (Figure 1 on page 2).
 - a. The inside of the top of the grille has hinges that pass through cutouts and engage with tabs on the mounting plate. With the bottom of the grille lifted out slightly, place the grille over the mounting plate so that the hinges of the grille are in the mounting cutouts.
 - b. Properly seat the grille by pressing the bottom in.
 - c. Fasten the bottom of the grille to the mounting plate by installing the captive combination drive screw.
7. Apply power and activate the horn/strobe unit to verify that it is operating properly.

Selecting the volume and tone

The horn has a jumper for selecting a high or low volume output level. The default is high volume. To set the output to low volume, remove the output jumper from the circuit board on the rear of the unit. See Figure 4 on page 3.

The horn has a jumper for selecting either a temporal or steady tone. The default is temporal tone. To set the output to steady tone, remove the tone jumper from the circuit board on the rear of the unit.

Tip: Save the jumper by sliding it onto a single pin.

Figure 1: Mounting diagram

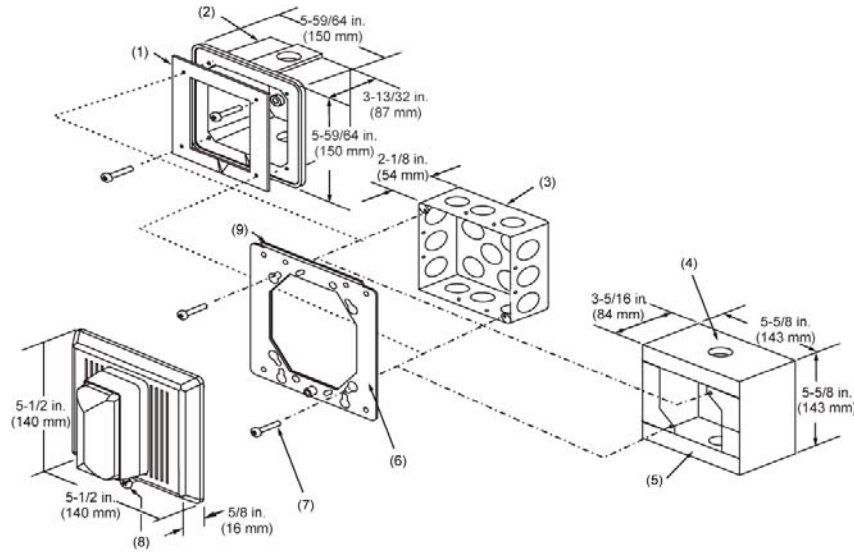
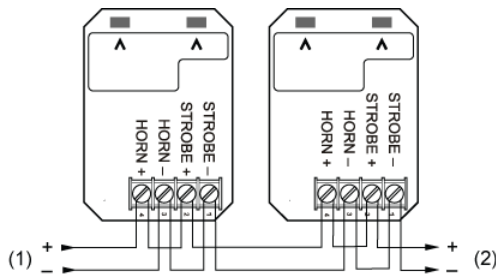

Figure 2: Typical one-circuit wiring diagram



Polarity is shown in the active state.

- (1) From voltage source.
- (2) To next device or end of line resistor.

The horn and strobe must be connected to a signal circuit having a constant (non-coded) voltage output.

Caution: Electrical supervision requires wire run to be broken at each terminal. Do not loop signaling circuit field wires around terminals.

Figure 3: Typical two-circuit wiring diagram

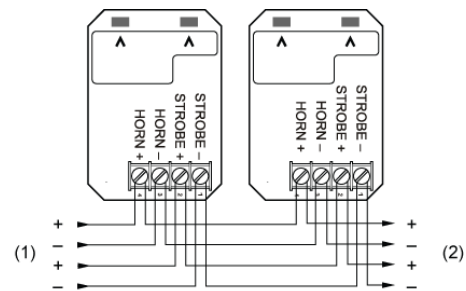

Polarity is shown in the active state.

- (1) From voltage source.
- (2) To next device or end of line resistor.

The strobe must be connected to signal circuits having a constant (non-coded) voltage output. The horn must be connected to a continuous voltage when it is set to sound a temporal tone; it may be connected to either a pulsed or continuous voltage when set to sound a steady tone.

Caution: Electrical supervision requires wire run to be broken at each terminal. Do not loop signaling circuit field wires around terminals.

Figure 4: Jumper setup and terminal block

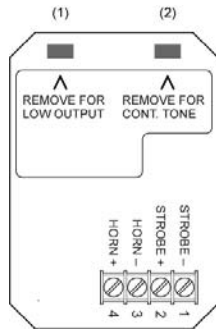

Item	In	Out
(1)	High output	Low output
(2)	Temporal tone	Steady (continuous) tone

Maintenance

Note: Do not change the factory-applied finishes.

This unit is shipped from the factory as an assembled unit; it contains no user-serviceable parts and should not be disassembled.

Perform a visual inspection and an operational test twice a year or as directed by the local authority having jurisdiction.

Specifications

Operating voltage	24 VDC
Strobe operating current	320 mA at 24 VDC
Horn operating current	See Table 2 below
Sound output	See Table 3 below
Operating temperature	
Indoor	32 to 120°F (0 to 49°C)
UL outdoor	-35 to 150°F (-37 to 66°C)
Relative humidity	
Indoor	93% noncondensing
Outdoor	98% noncondensing

Table 2: Maximum horn operating current [1]

Voltage	Low Volume	High Volume
24 VDC	20 mA	48 mA

[1] Horn and strobe currents are additive when connected in parallel.

Table 3: Anechoic chamber, average peak sound output (dBA) [1]

Method	Low	High
24 VDC	95	101

[1] Sound level output at 10 ft. (3.05m)

Regulatory information

Manufacturer	Edwards, A Division of UTC Fire & Security Americas Corporation, Inc. 8985 Town Center Parkway, Bradenton, FL 34202, USA
Year of manufacture	The first two digits of the date code (located on the product identification label) are the year of manufacture.
UL rating	24 DC
Environmental class	Indoor, outdoor
North American standards	Meets: UL 464 and UL 1638
FCC compliance	This equipment has been tested and found to comply with the limits for a Class A digital device, pursuant to Part 15 of the FCC rules and regulations.

Contact information

For contact information, see www.edwardssignaling.com.