

# 7007B-N5 Audible/Visible Signal-Strobe Installation Sheet

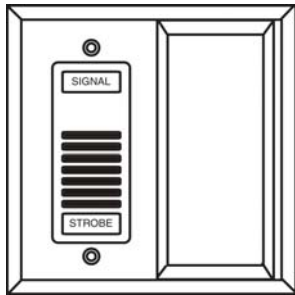

## Description

The 7007B-N5 series audible/visible signal-strobes are UL Listed for general purpose signaling applications.

**Table 1: Models**

Number	Description
7007BA-N5	Amber lens
7005BB-N5	Blue lens
7007BG-N5	Green lens
7007BR-N5	Red lens
7007B-N5	Clear lens

## Installation

### WARNINGS

- **Electrocution hazard.** A qualified electrician familiar with National Electrical Code and local code requirements must install this product. Failure to follow the safety precautions in this installation sheet could result in product or property damage, or severe personal injury or death.
- **Electrocution hazard.** To reduce the risk of shock, do not remove the lens or tamper with the unit when the circuit is energized. Disconnect power and allow five (5) minutes for stored energy to dissipate before starting work or disassembly. High energy could be stored in the strobe circuit once it is energized.

The signal-strobe (Figure 1) can be mounted on a Listed single-gang 2 x 4 in. (51 x 102 mm) electrical box, double-gang 4 x 4 in. (102 x 102 mm) electrical box, or standard 4 x 4 in. (102 x 102 mm) junction box with a plaster ring.

### To install the signal-strobe:

1. Install an appropriate electrical box using suitable hardware.
2. Connect the wire leads as shown in Figure 2.
3. Mount the device to the electrical box. Secure it using two screws (supplied).
4. Perform an operational test.

Figure 1: Details of 7007B-N5

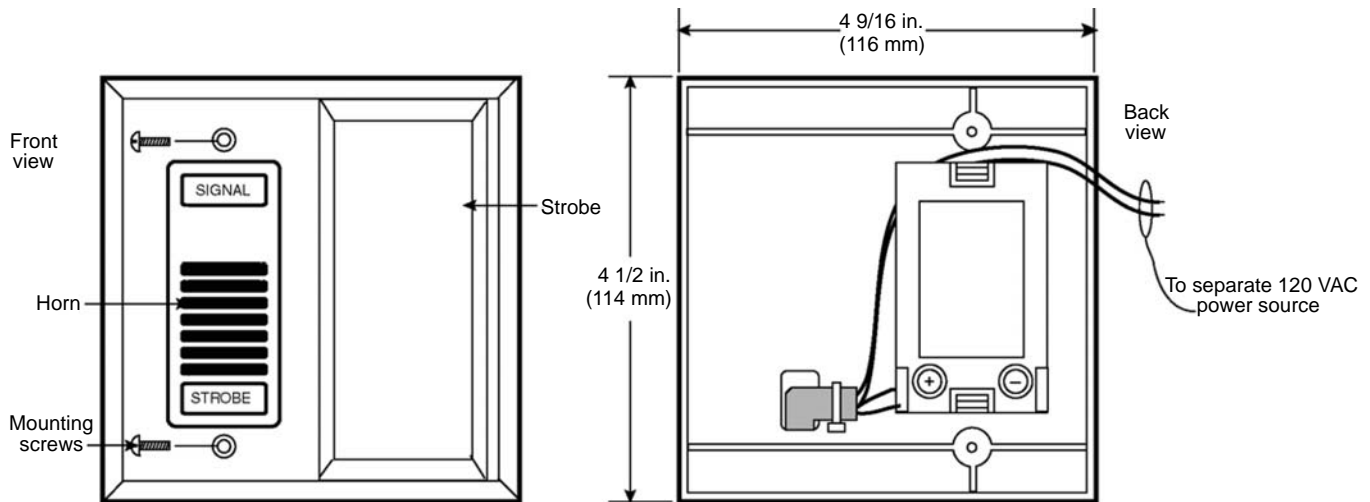

## Wiring

See Figure 2 for wiring connections.

Figure 2: Wiring connections

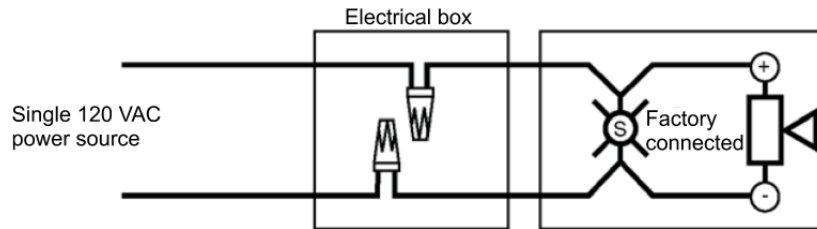

## Maintenance

**WARNING:** Electrocutation hazard. To reduce the risk of shock, do not remove lens or tamper with unit when the circuit is energized. Disconnect power and allow five (5) minutes for stored energy to dissipate before starting work or disassembly. High energy could be stored in the strobe circuit once it is energized.

Perform regularly scheduled testing at least twice a year or more often as dictated by local authorities having jurisdiction.

## Specifications

Operating voltage	120V 60 Hz
Alarm current	115 mA

## Regulatory information

Manufacturer	Edwards, A Division of UTC Fire & Security Americas Corporation, Inc. 8985 Town Center Parkway, Bradenton, FL 34202, USA
North American standards	UL 464, UL 1638

## Contact information

For contact information, see [www.edwardssignaling.com](http://www.edwardssignaling.com).